

# FE170CG

## Introduction & Training

# FE170CG Outline

- System Block Diagram
- Component and PCB Board Introduction
- Power On Sequence
- Equipment Requirement
- Trouble Shooting Guide

# System Block Diagram

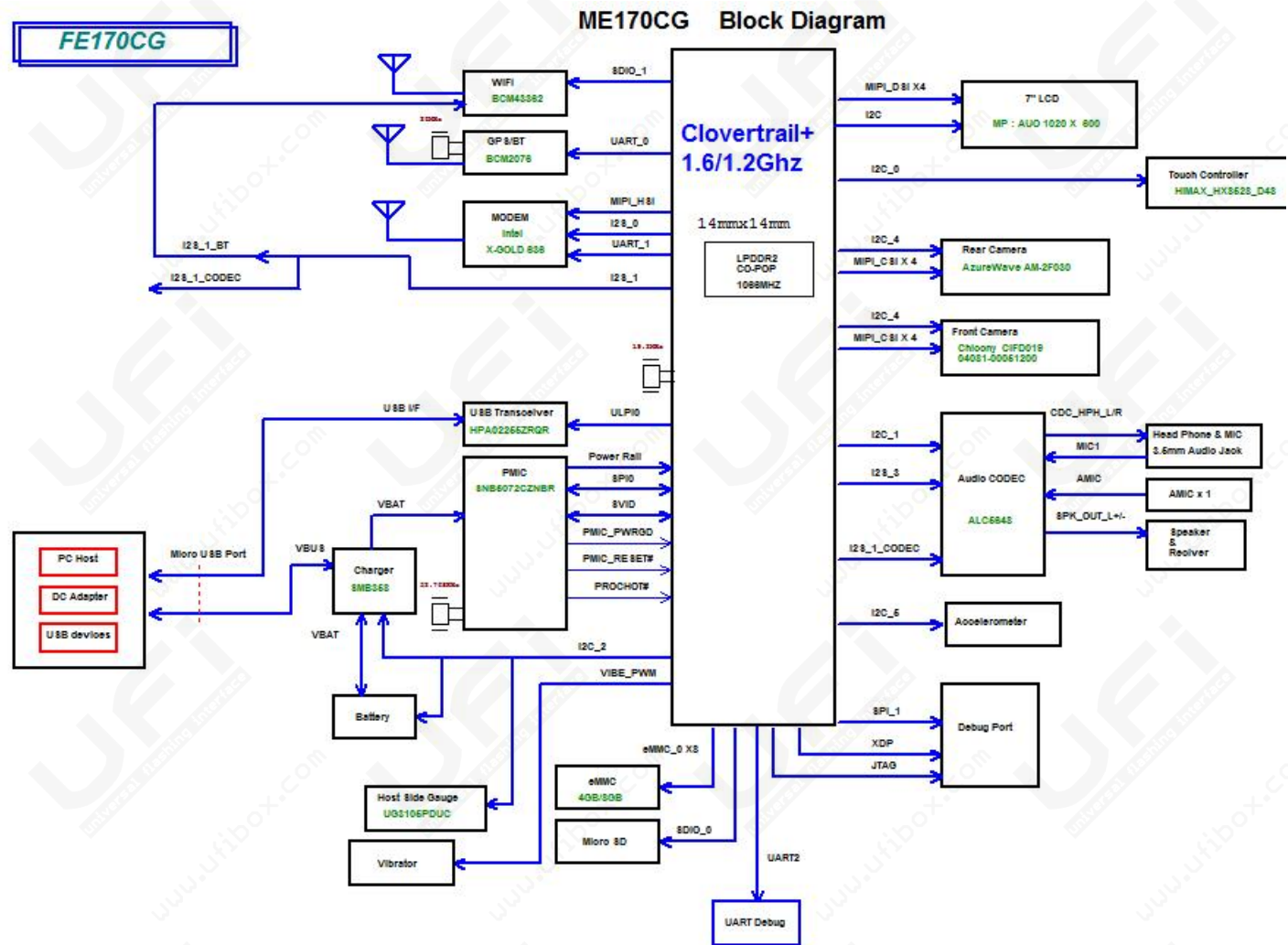

# FE170CG Outline

- System Block Diagram
- **Component and PCB Board Introduction**
- Power On Sequence
- Equipment Requirement
- Trouble Shooting Guide

# Outline Introduction (TOP)



# Outline Introduction (BOT)



# Outliner introduction (Take off th

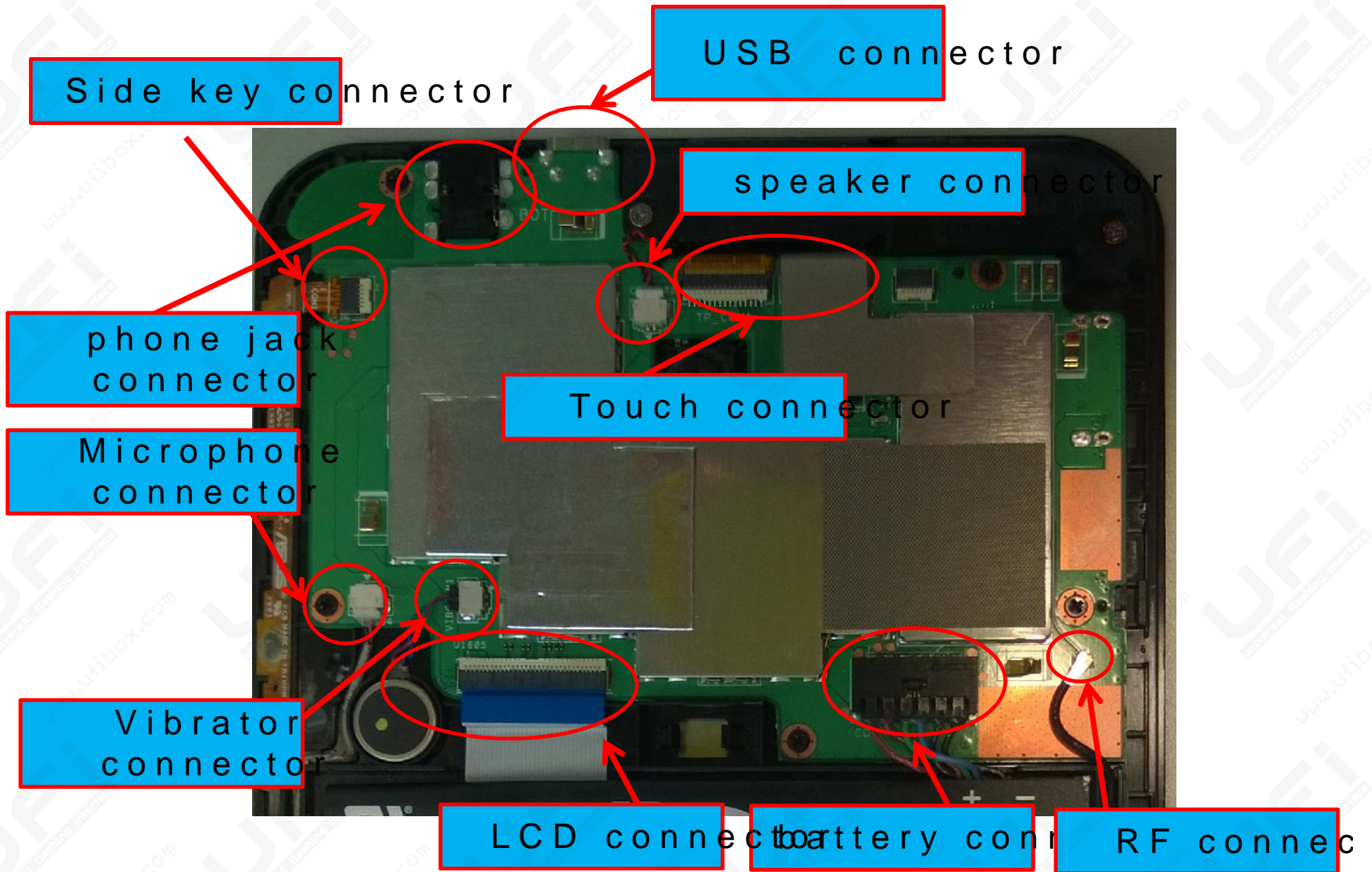

# PCB Board Introduction (TOP)

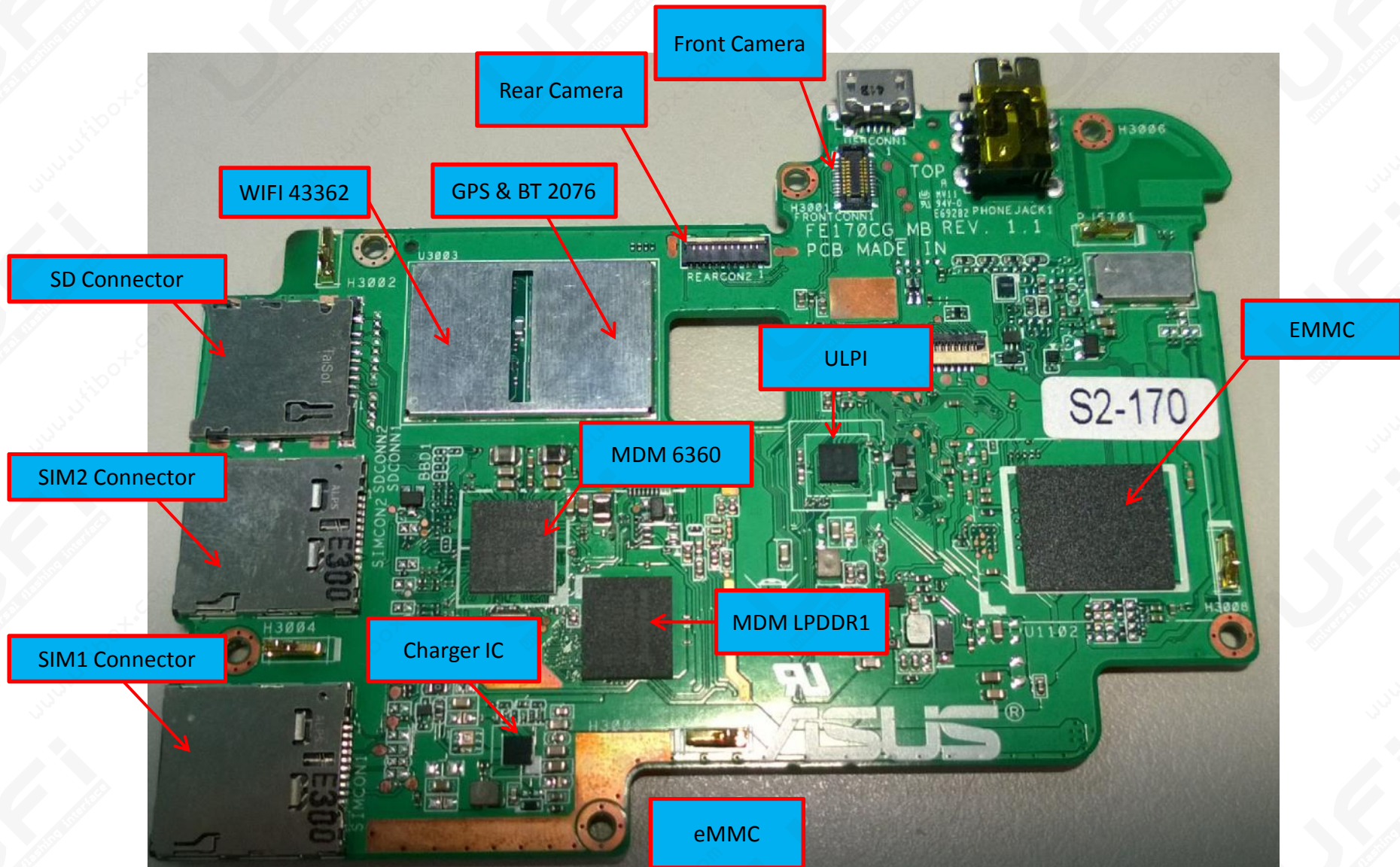



# PCB Board Introduction (BOT)

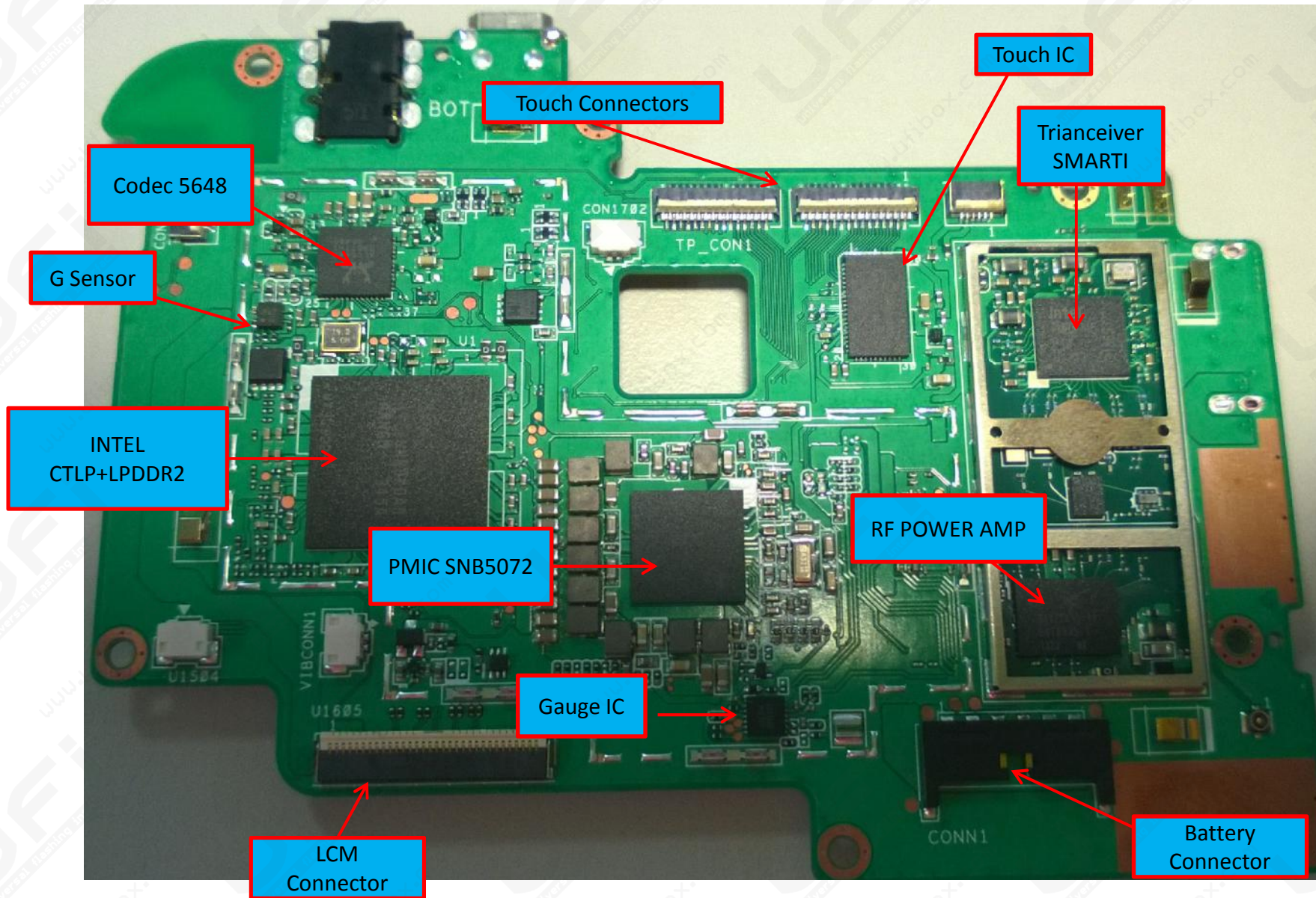

# FE170CG Outline

- System Block Diagram
- Component and PCB Board Introduction
- **Power On Sequence**
- Equipment Requirement
- Trouble Shooting Guide

# Power Sequence (PMIC SNB)

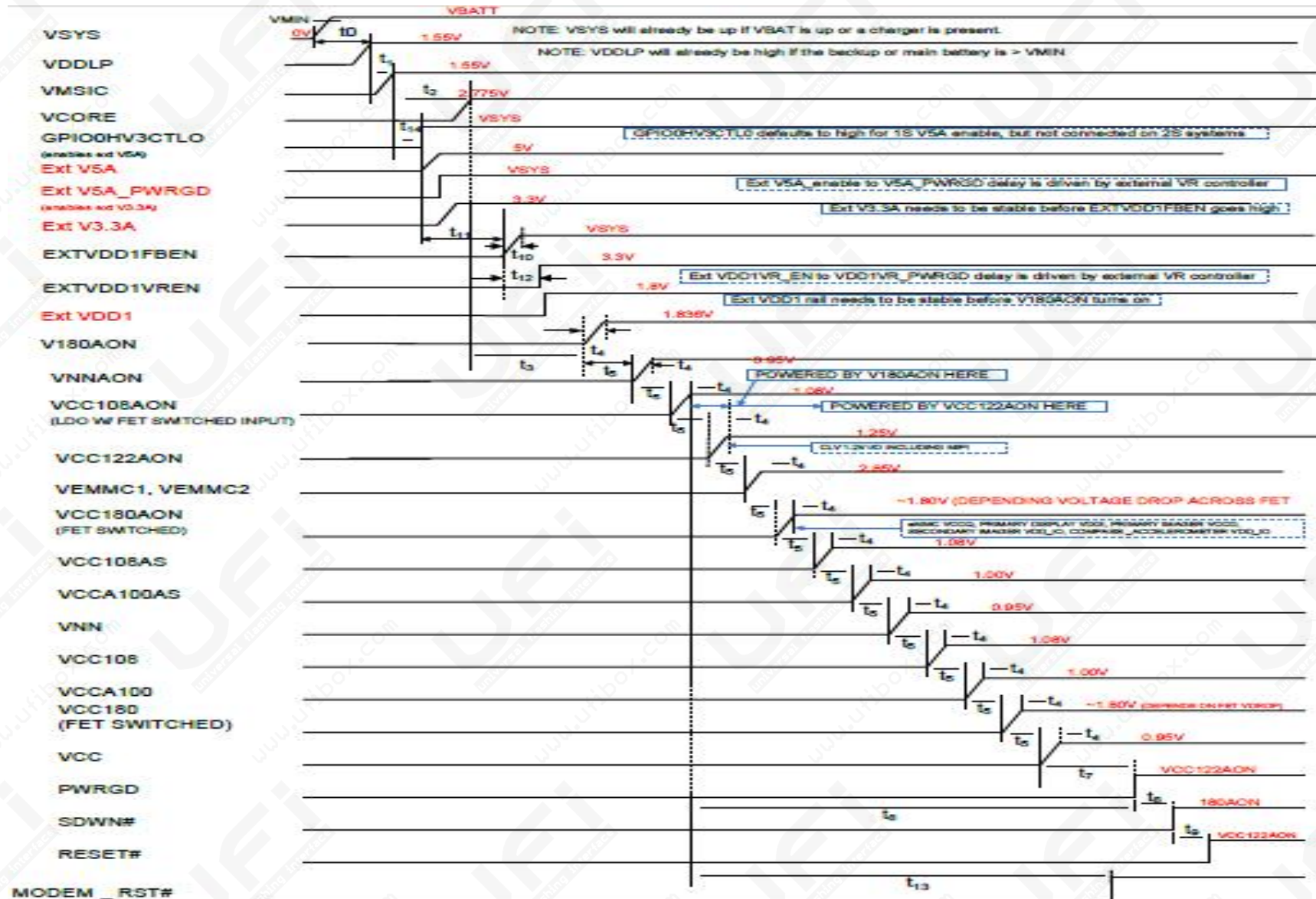

# FE170CG Outline

- System Block Diagram
- Component and PCB Board Introduction
- Power On Sequence
- **Equipment Requirement**
- Trouble Shooting Guide

# Equipment Requirement

- Power supply: DC 4V
- Oscilloscope
- Digital Multi-Meter
- AC charger of FE170CG
- Battery of FE170CG
- Micro USB cable
- Micro SIM card
- Ultra SD card

# FE170CG Outline

- System Block Diagram
- Component and PCB Board Introduction
- Power On Sequence
- Equipment Requirement
- **Trouble Shooting Guide**

# Trouble Shooting Guide

1.No boot

7.Cam error

2.Power on no 8.Main MIC error

3.Can not charge 9.eMMC

4.Can not cable 10SIM Card  
on

11SD Card

5.Can not Hard 12G sensor  
reset

13Speaker

6.Touch error

14Headset

# Trouble Shooting Guide

## no boot

- Check the BATT have 3.7V or not,
  - BATT voltage < 3.5V -->Changer , Wait battery voltage >3.7V , Boot again
  - Change BATT
- Check CONN1, PSR9609,PSR9606, PSR9605 have short or open
- Check R1704.1 voltage 3.7~4.2V
- Check R1703, R1702, R1704, R1705, R1701, CON1701 have short or open
- Check  
U1,U6401,BBU1,PU8401,U1201,U8301,PU8101,PU9601,U1502,U2302,U1801,BBU5301,U2,U1102,U1501,U2301,PU8901 And peripheral circuit have open or short
- Check PC8401.1 voltage >3.7V
- Check V\_VNNAON = 0.60V
- Check V\_1P22\_VCCAON = 1.25V
- Check V\_1P80\_AON = 1.836V



# Trouble Shooting Guide

## no boot

- Check V\_VCC = 0.8 ~ 1.2V
- Check V\_VNN = 0.6 ~ 1.2V
- Check V\_1P80\_AON =1.8V
- Check +3VSUS =3.1~3.3V
- Check V\_2P80\_CORE =2.80V
- Check V\_1P08\_VCC =1.08V
- Check V\_1P08\_VCCAON =1.08V
- Check V\_1P00\_VCCA =1V
- Check V\_1P00\_VCCAS =1V
- Check V\_1P08\_VCCAS =1.08V

# Trouble Shooting Guide

## power on no display

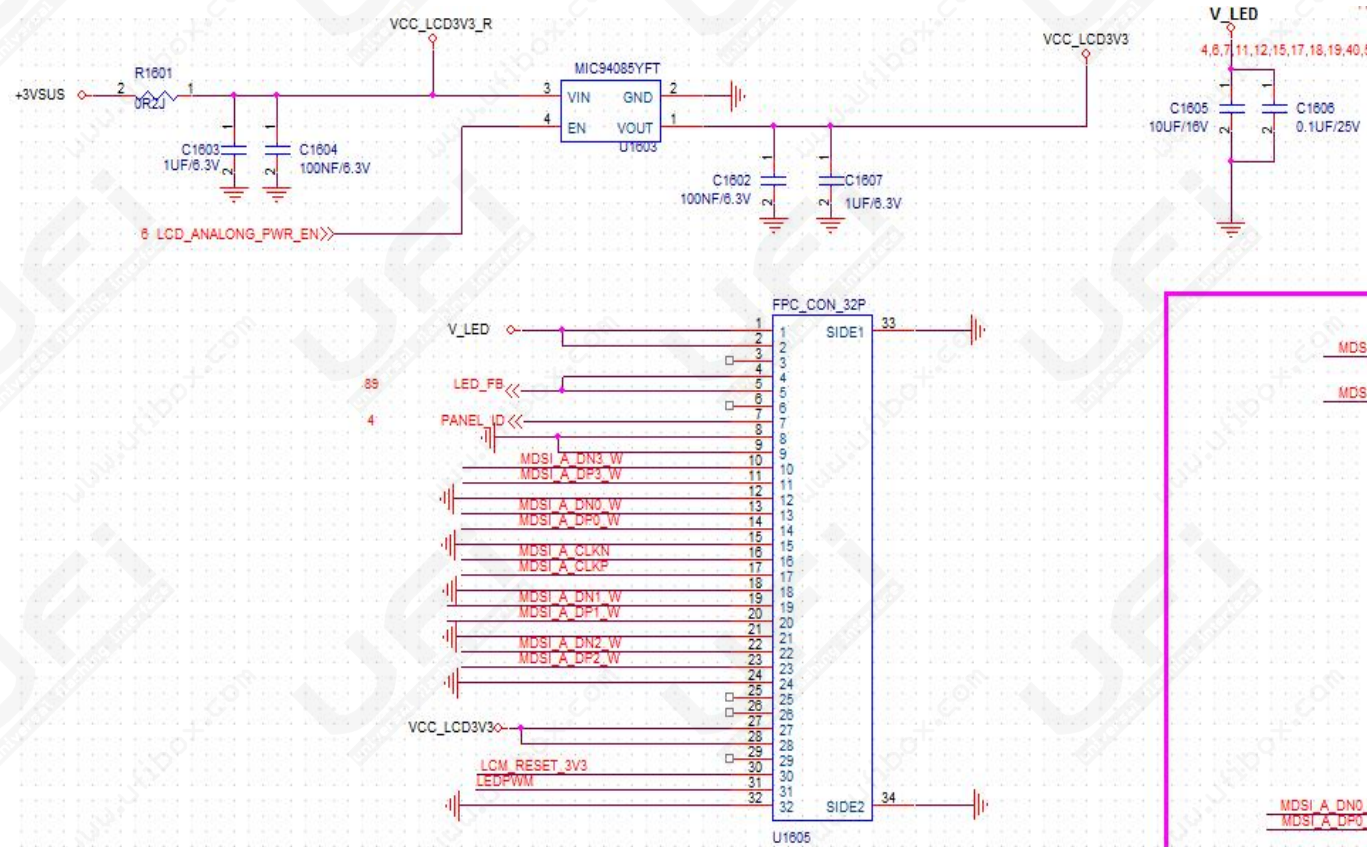

- Check U1605, U1603, R1601 have open or short
- Check VLED voltage 9.3~10.35V

# Trouble Shooting Guide

## can not charge

- Plug USB cable then check R1303.1 & PL8101 = 5V.
- Check CHGOUT=3V~4.2V.
- Check CHG\_EN=0V
- Check PR8117, PU8101 open or not

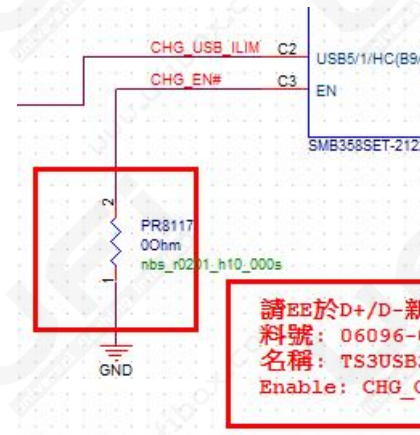
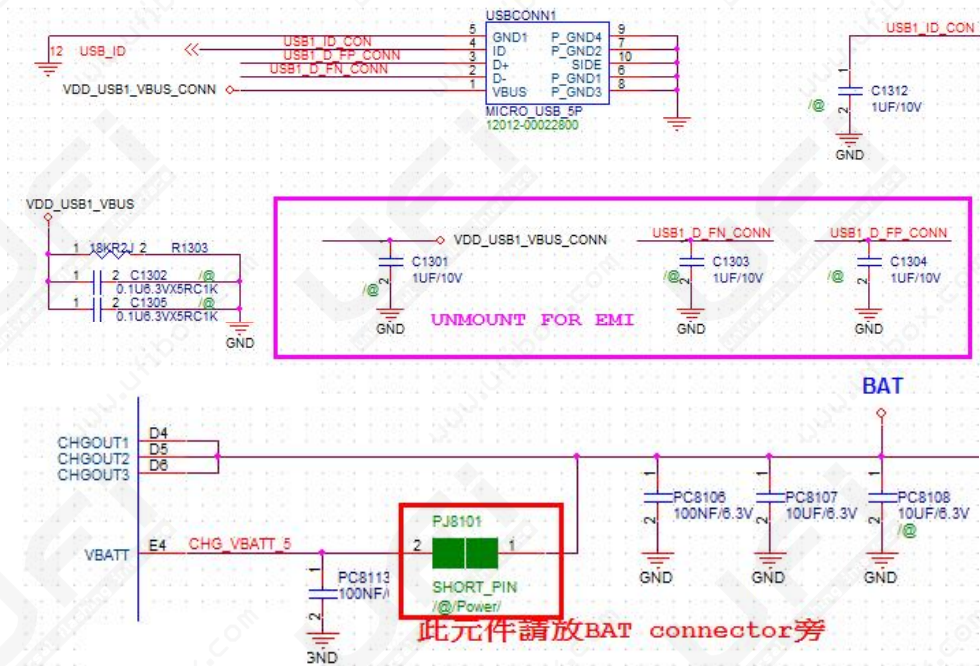

# Trouble Shooting Guide

## can not cable power on



- Check PU8401,U1201,PR8612 have open or short
- Plug in USB charger then check C1204.1 voltage=5V
- Plug in USB charger then check PR8612 voltage=0V

# Trouble Shooting Guide

Press Power key 7 seconds

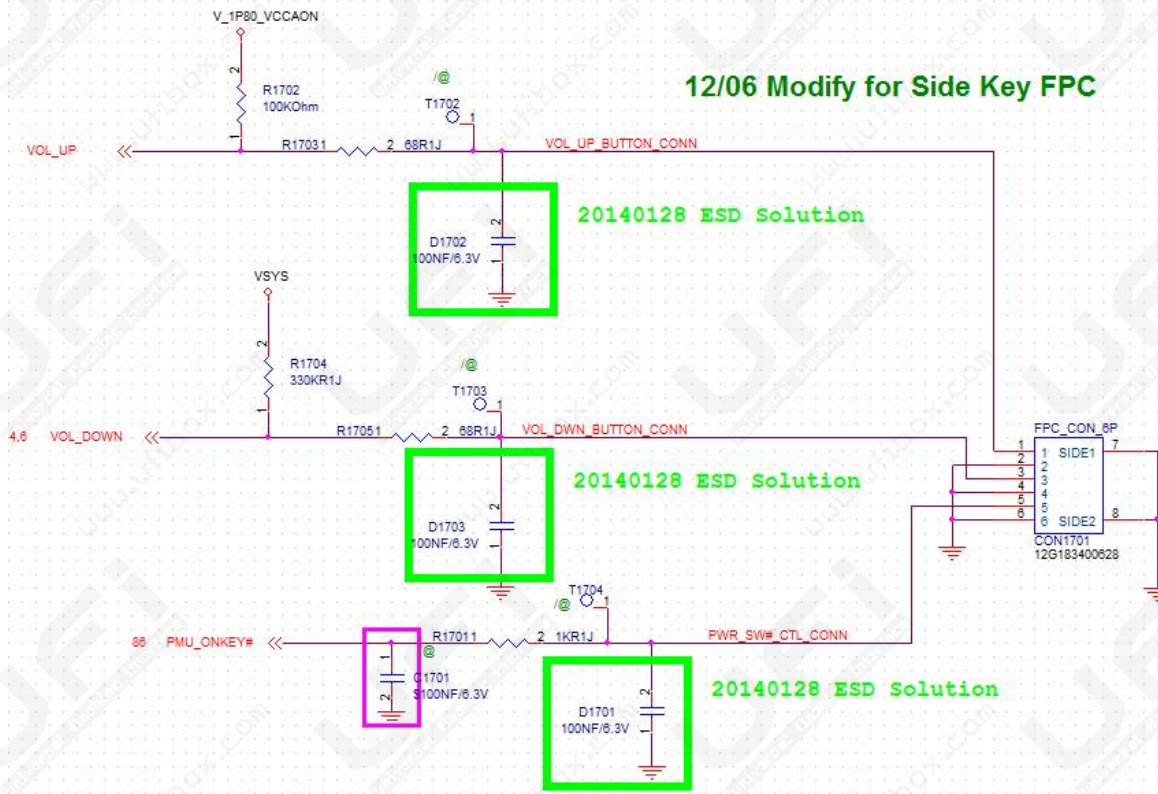

- Check R1702, R1704, R1705, R1701 open or short

# Trouble Shooting Guide

## Camera error

- Please confirm Camera has mounted to REARCON2
- Check REARCON2 damage or not
- Check R2013, R2012, R4203, R2006, SER4239 have open or short
- Please confirm Camera has mounted to 001
- Check R2001 damage or not
- Check R2013, R2012, R4203, R2005, R2008, open or short

# Trouble Shooting Guide

## M I C e r r o r

### ANALOG MIC CONN.

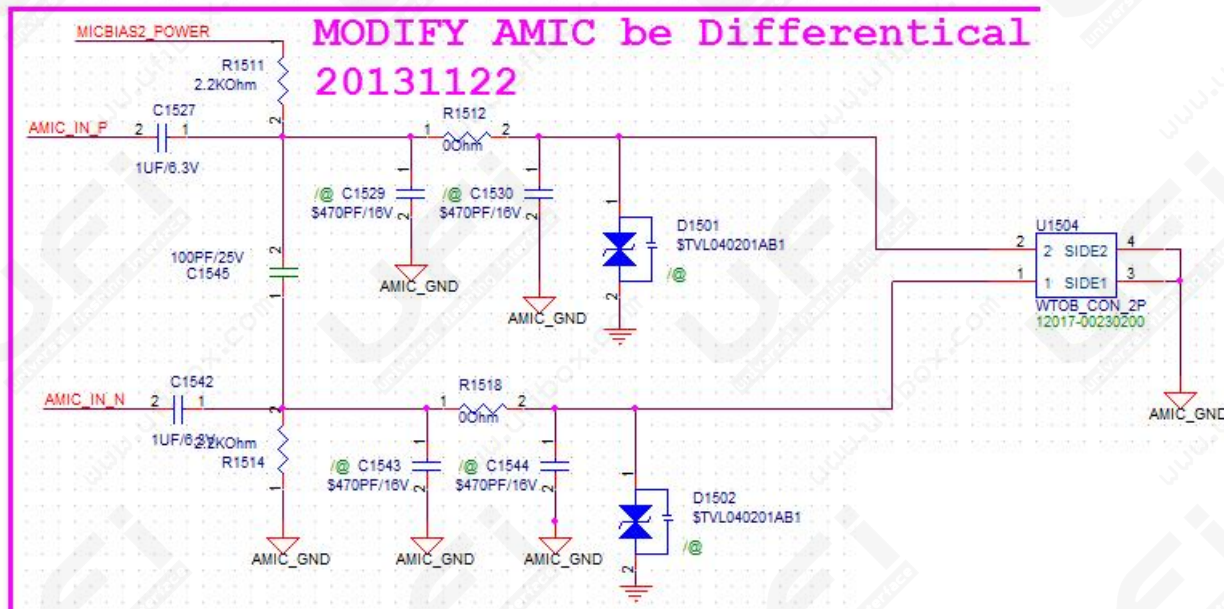

- Check R1512, R1518, R1511, R1514, C1545, C1529, C1530, C1542, C1543, C1544, C1545, D1501, D1502 have or short
- Change MIC

# Trouble Shooting Guide

## Speaker

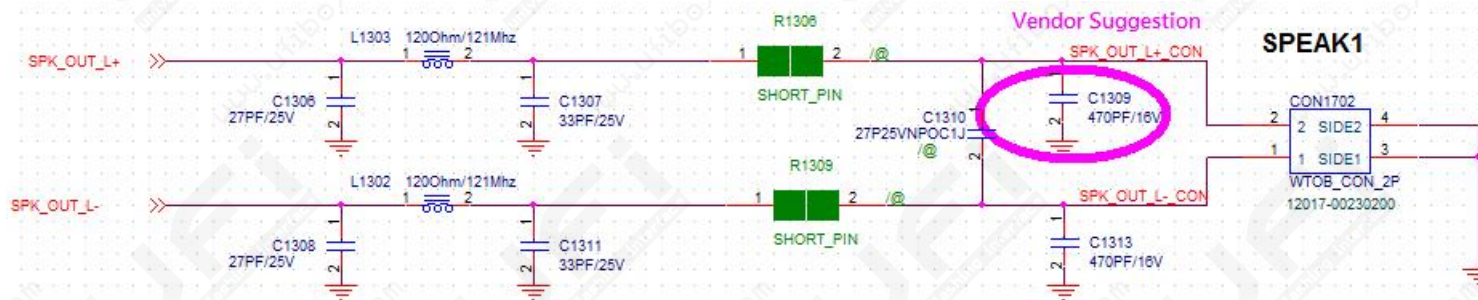

- Check U1502, CON1702 ,L1303, L1302 have open or short
- Check U1502 And peripheral circuit have open or short



# Trouble Shooting Guide

## Headset

- Check PHONE JACK1, R1405, or damage
- Check as peripheral circuit or short

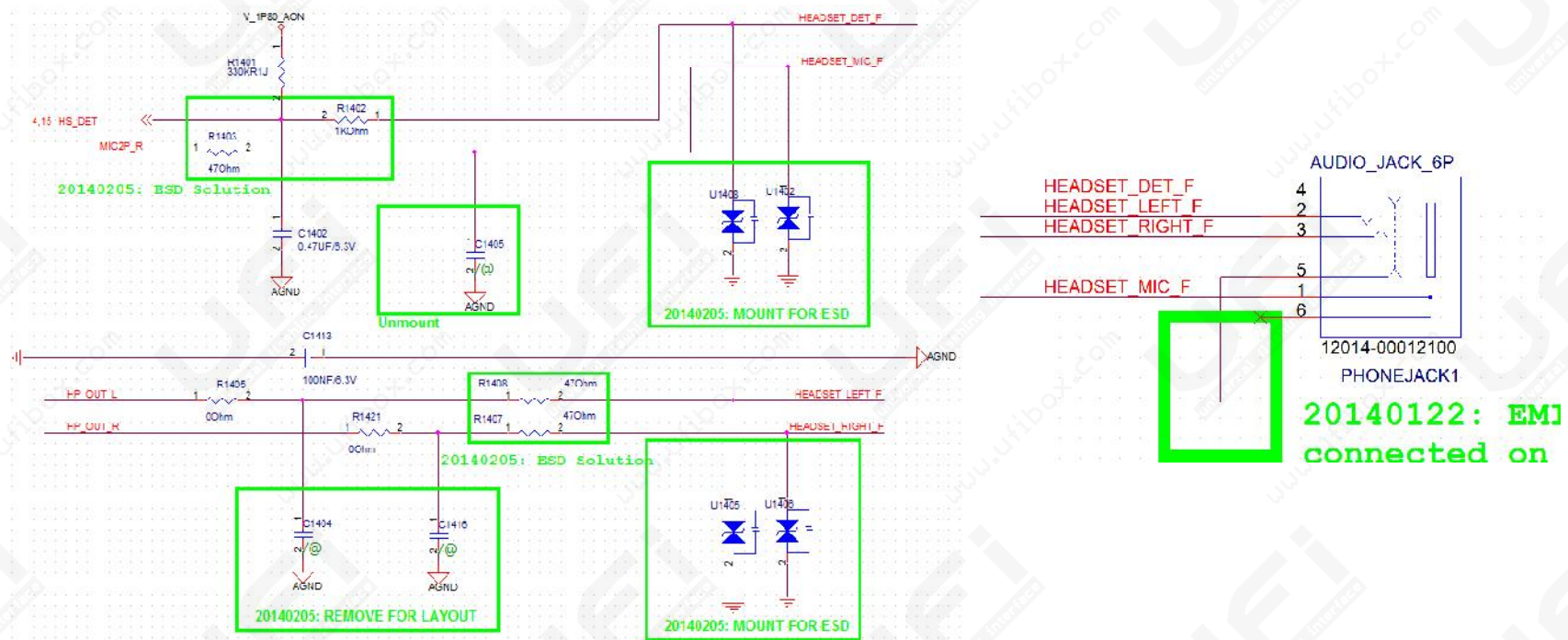

# Trouble Shooting Guide

## Headset

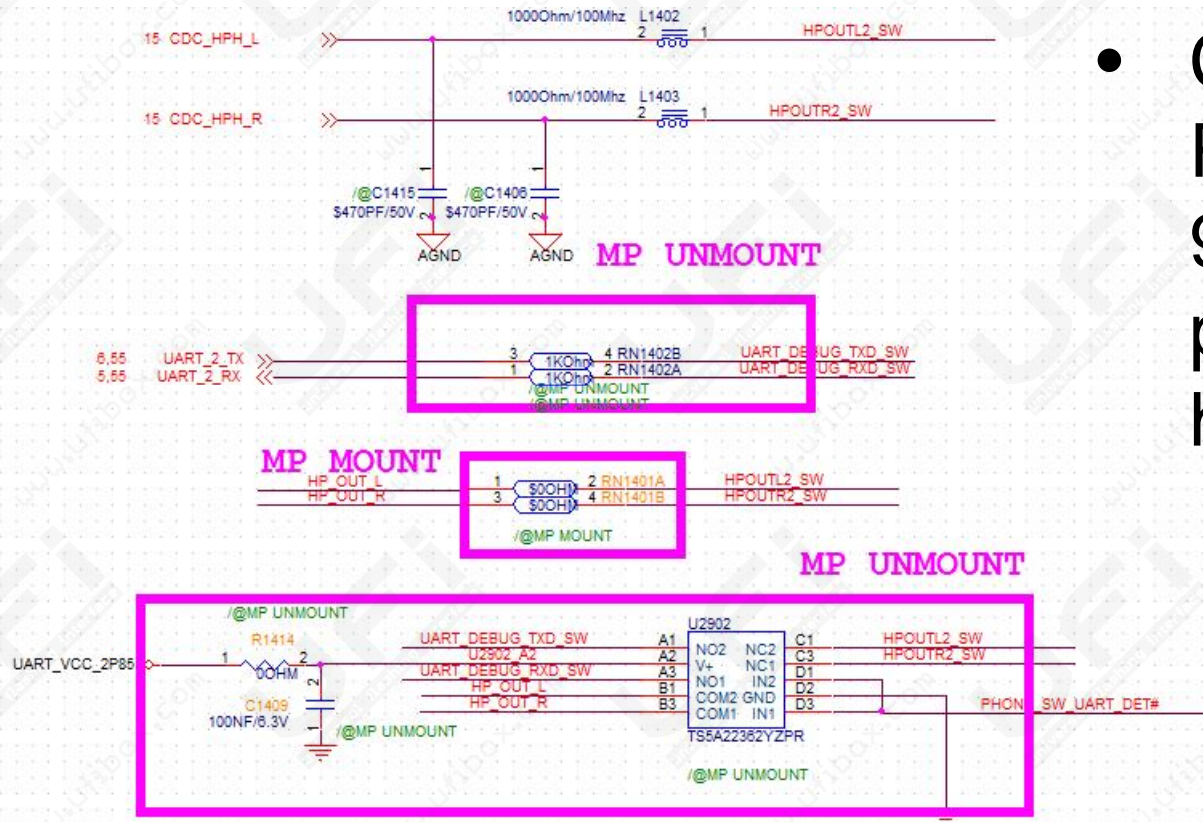

- Check L1402, L1403, R1401, R1402, RN1401, RN1402 peripheral circuit have operation

IN	NC TO COM, COM TO NC	NO TO COM, COM TO NO
L	ON	OFF
H	OFF	ON

# Trouble Shooting Guide

## Headset connector

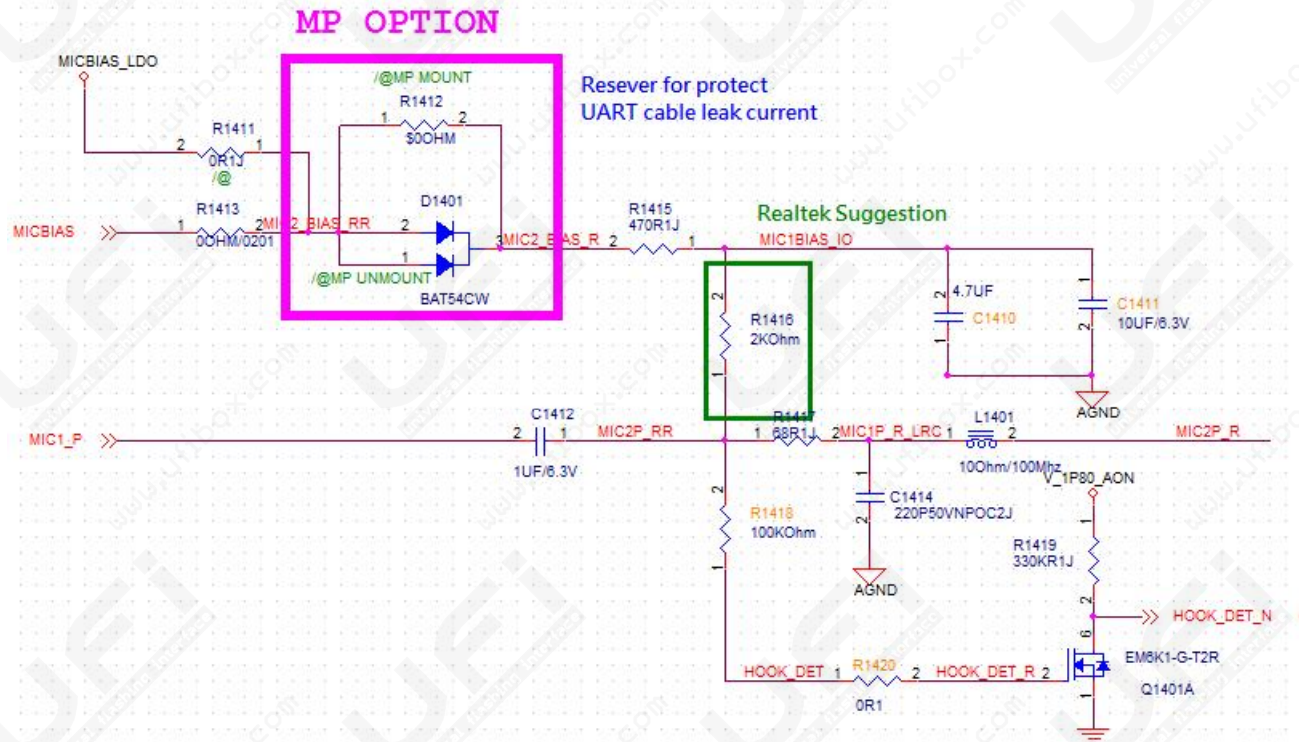

- Check MICBIAS = 2.85V
- Check R2219 have open or n

# Trouble Shooting Guide

## eMMC

- Check U1102 have open or not
- Check  $+3vsus=3.3V$
- Check  $emmc\_vccq\_1p80=1.8V$

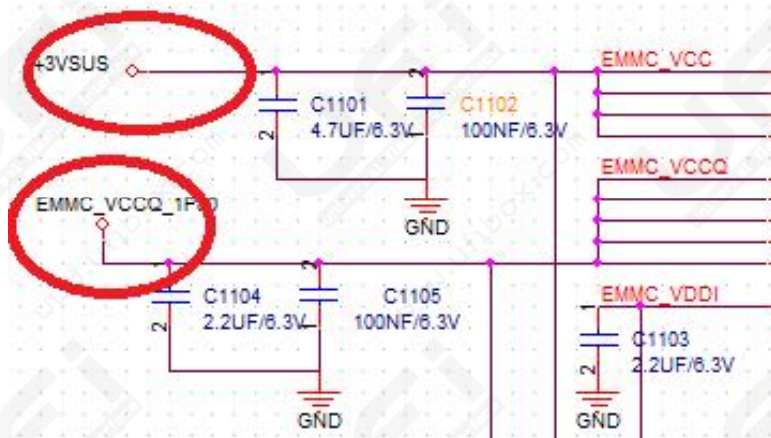

# Trouble Shooting Guide

## G sensor

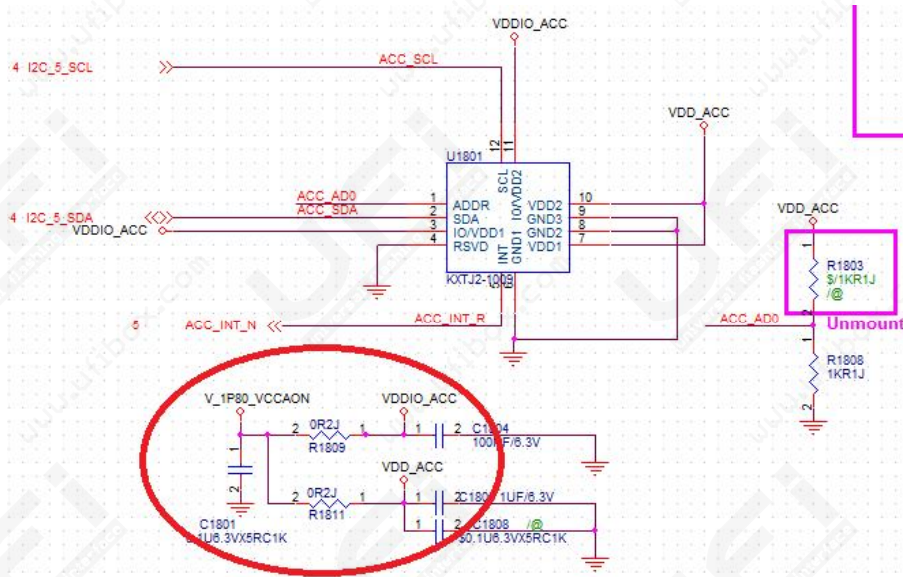

- Check U1801 have open or not
- Check VDDIO\_ACC & VDD\_ACC = 1.8V
- Check ACC\_AD0 = 0V
- Check R1809, R1811 have open or not

# Trouble Shooting Guide

## Modem

### FE170CG MDM ID LLT

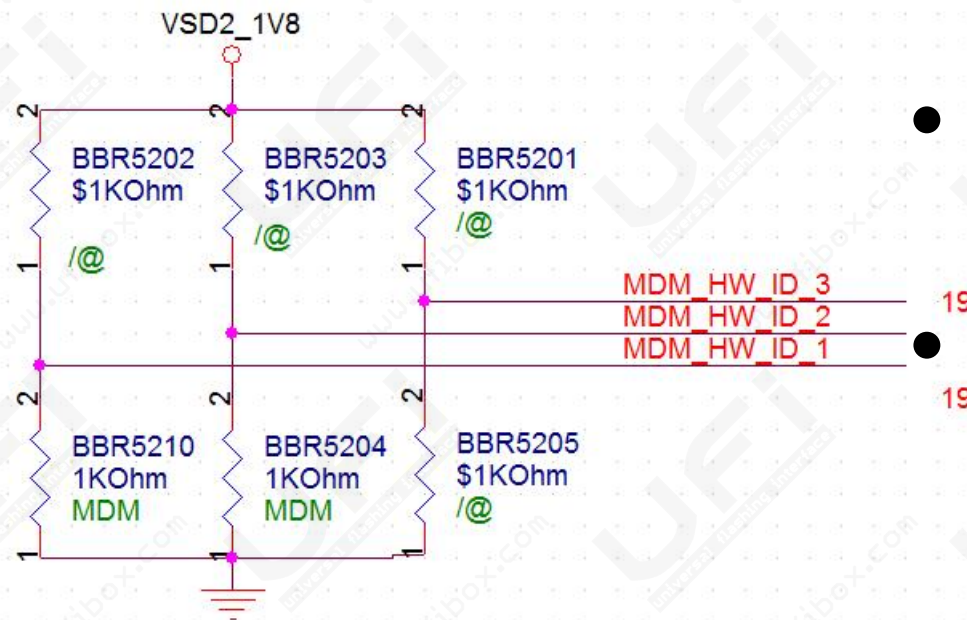

- Check VSD2\_1V8 = 1.8
- Check BBU1 h damage or not
- Check BBR5210, BBR5204 have damage c
- Check MDM MLTD

# Trouble Shooting Guide

## Modem

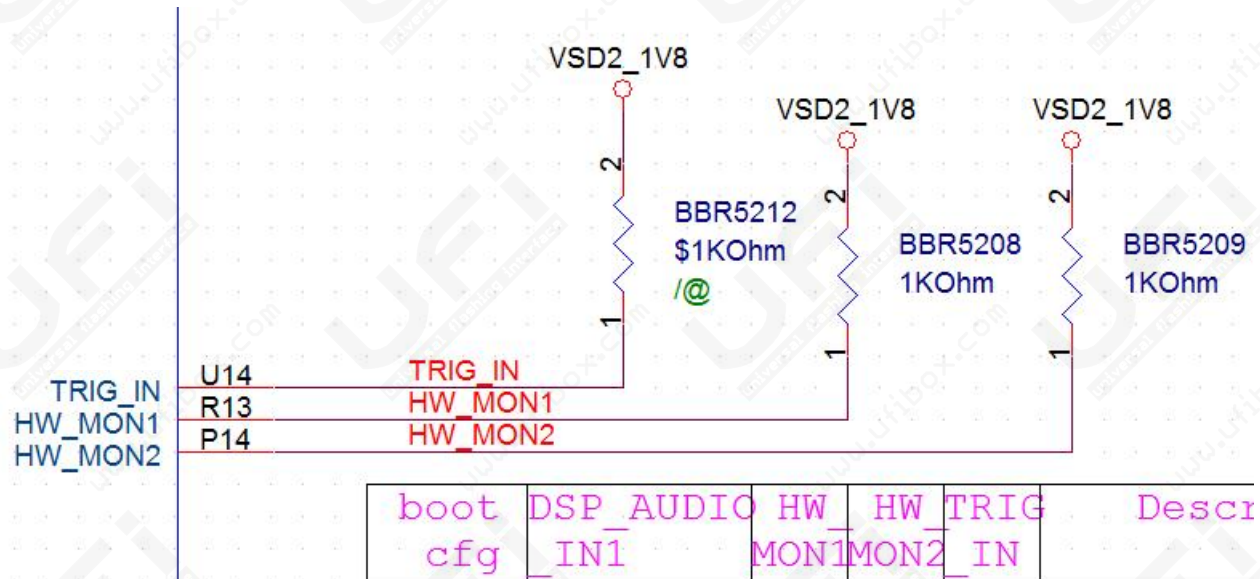

- Check BBR5208, BBR5209 have damage or not

# Trouble Shooting Guide

## SIM card

- Check voltage  
 $VSD2\_1V8 = 1.8V$ ,  $VSIM1\_VAR$ ,  
 $/1.8V$
- check  $SIM2\_DET\_N \neq S.I8M1\_DE$
- check  $SIMCON1$ ,  $SIMCON2$  hav

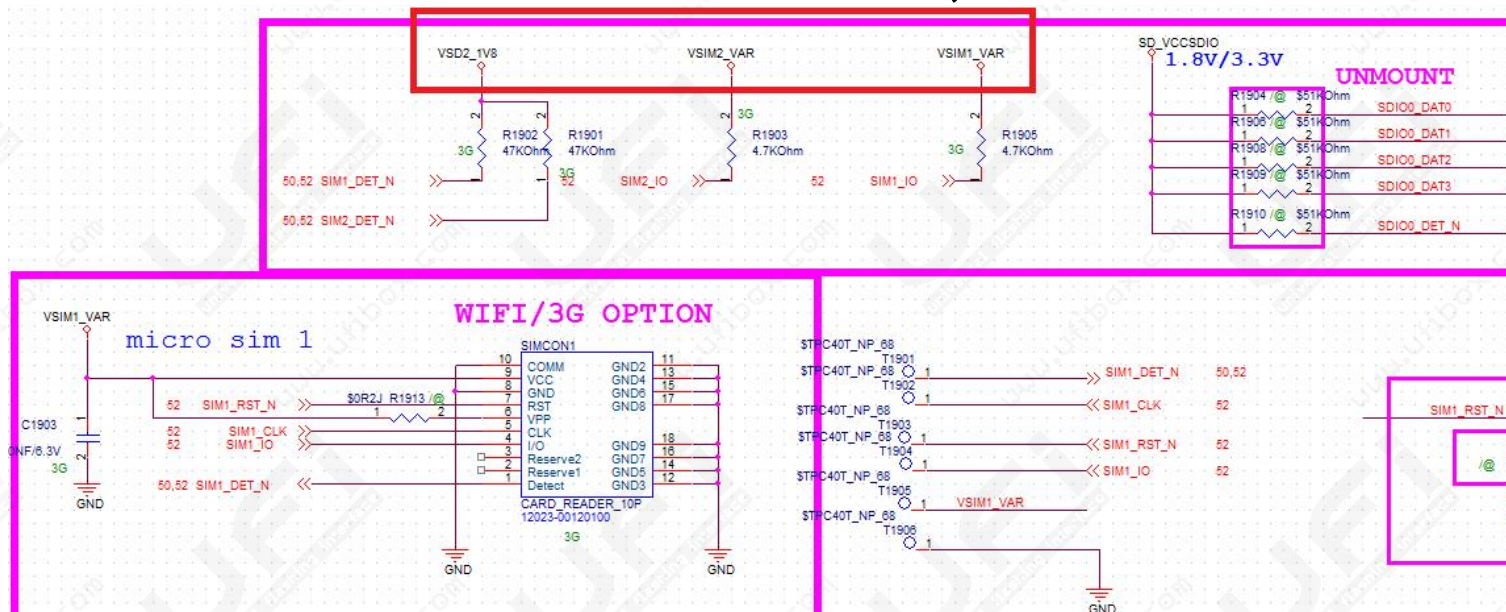



# Trouble Shooting Guide

## SD Card

- Check SD\_VCCSDIO=2.85V/1.8V
- Check SDCONN1 have open or short
- Check SDIO0\_DET\_N=1.8V

SD Card Connector  
SDCONN1: 3G  
SDCONN2: WIFI

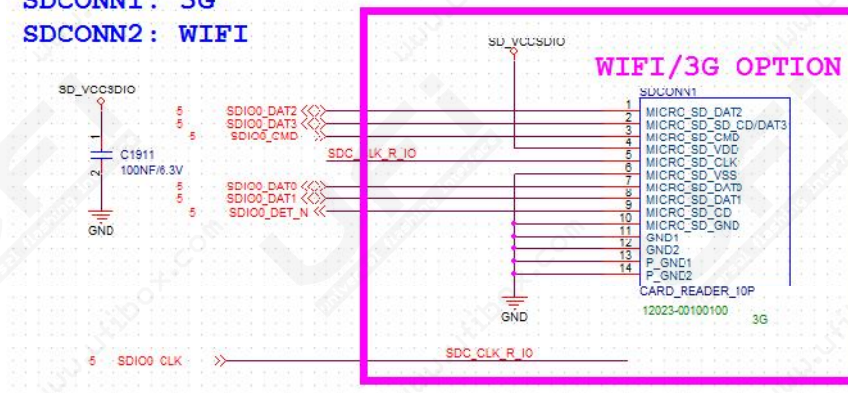

# Trouble Shooting Guide\_SUB

## Touch error

- Check SENSOR has connected to MB
- TP\_CON1,TP\_CON2 have open or damage
- Check SENSOR FPC damage or not
- TP\_CON1,TP\_CON2 CONNECTOR damage or not

# Trouble Shooting Guide\_SUB

## T o u c h e r r o r

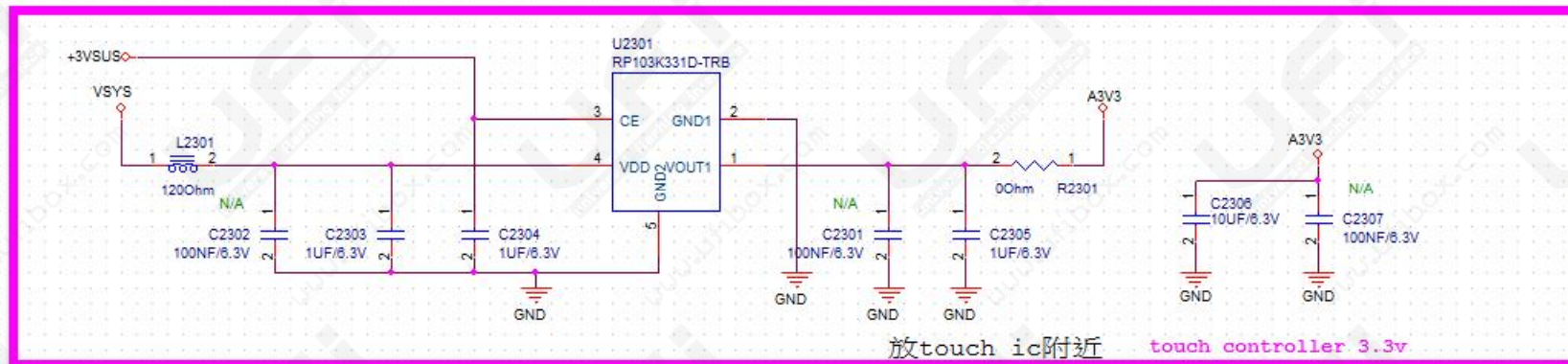

- Check L2301, R2301, U2301 have or short
- Check A3.3, V<sub>D</sub>1 V8 = 1.8V, TS = A V D :

# Trouble Shooting Guide\_SUB

## Touch error

- MPAP FAIL:
  - Check MPAP version,
  - Check FPC has connect TP\_CON1,TP\_CON2
  - Check FPC damage or not

*Thanks for  
your Attention*