

BB SCHEMETIC

1. Contents
2. PM8029 POWER Circuit
3. PM8029 Analog/CFG/CLOCK and RF Interface
4. MSM8225 Power Filter
5. MSM8225 Analog Circuit and RF interface
6. MSM8225 NAND+DDR2 MCP Circuit
7. MSM8225 MCP interface & GND
8. MSM8225 GPIO Data UI and Other Interface
9. USB/Charge management/Battery/Vibrator
10. Main Camera; Slave Camera and Flash Circuit
11. 3.5 Headphone port
12. Sensor/Status indicator
13. LCD interface /LCD backlight driver
14. SIM/TF card interface
15. SPK/RCV/MIC
16. Keypad/Touch
17. Test Points/JTAG/Shields
18. eMMC+LPDDR2 MCP Circuit
19. Power Map

RF SCHEMETIC

20. DCDC For RF PA
21. RF Input Output Ports
22. 19.2MHz VCTCXO
23. Antenna Switchplexer
24. WCDMA IMT Power Amplifier
25. WCDMA CELL Power Amplifier
26. GSM Quad_band_PA
27. RX MATCHING CIRCUIT
28. UMTS IMT RX INTERSTAGE CHAIN
29. RTR6285A CIRCUIT
30. RTR6285A POWER DISTRIBUTION
31. GPS
32. WCDMA PCS Power Amplifier
33. NA
34. NFC
35. BT FM WCN2243
36. AR6005 BB
37. AR6005 RF

The type and specification of the components refer to the BOM

				NA	
				ECA NO	DATE
DESIGNED	ZHANGSAN XXXXX	HD1G520M		00001234	
REVIEWED	LISI XXXXX	VER	PART_NUMBER	SHEET 1 OF 37	
		A	03030001	HUAWEI TECH CO.,LTD.	

2. PM8029 POWER Circuit

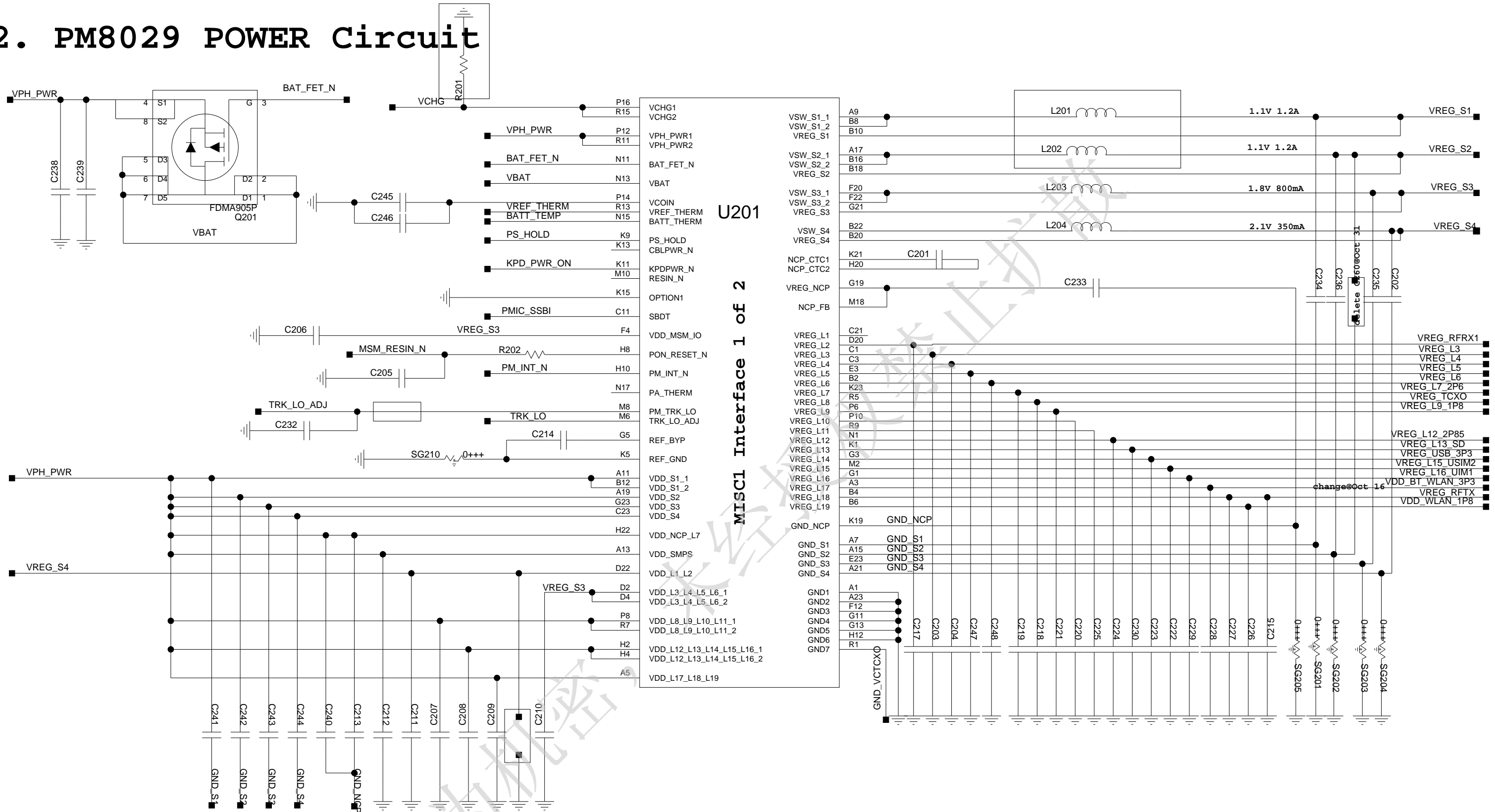

MISC1 Interface 1 of 2

The type and specification of the components refer to the BOM

				NA	
				ECA NO	DATE
DESIGNED	ZHANGSAN XXXXX	HD1G520M		00001234	
REVIEWED	LISI XXXXX	VER	PART_NUMBER	SHEET 2 OF 37	
		A	03030001	HUAWEI TECH CO.,LTD.	

3. PM8029 Analog/CFG/CLOCK and RF Interface

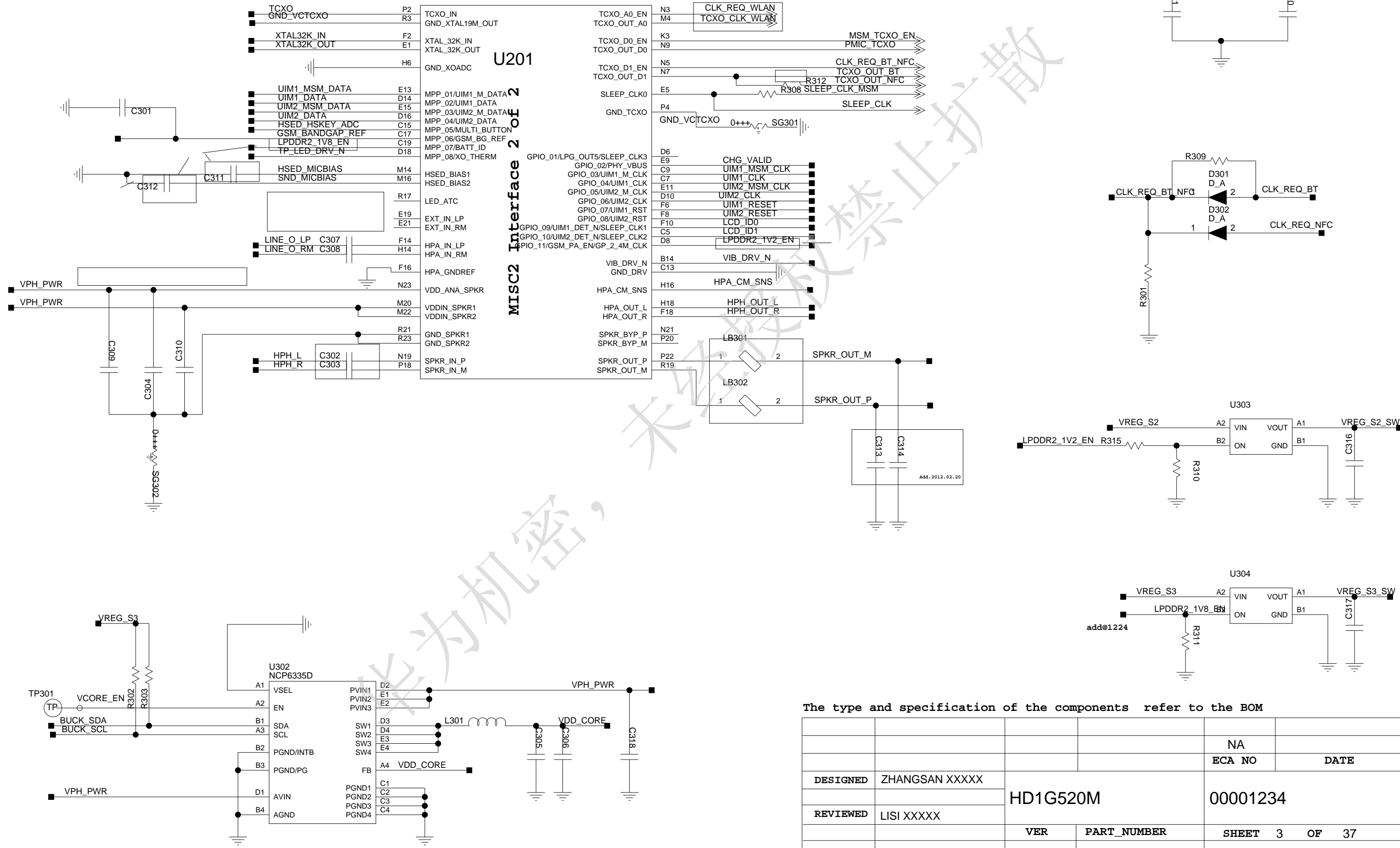

The type and specification of the components refer to the BOM

DESIGNED	ZHANGSAN XXXXX	HD1G520M		NA	
REVIEWED	LISI XXXXX	00001234		ECA NO	DATE
		VER	PART_NUMBER	SHEET 3 OF 37	
		A	03030001	HUAWEI TECH CO.,LTD.	

4. MSM8225Q Power Filter

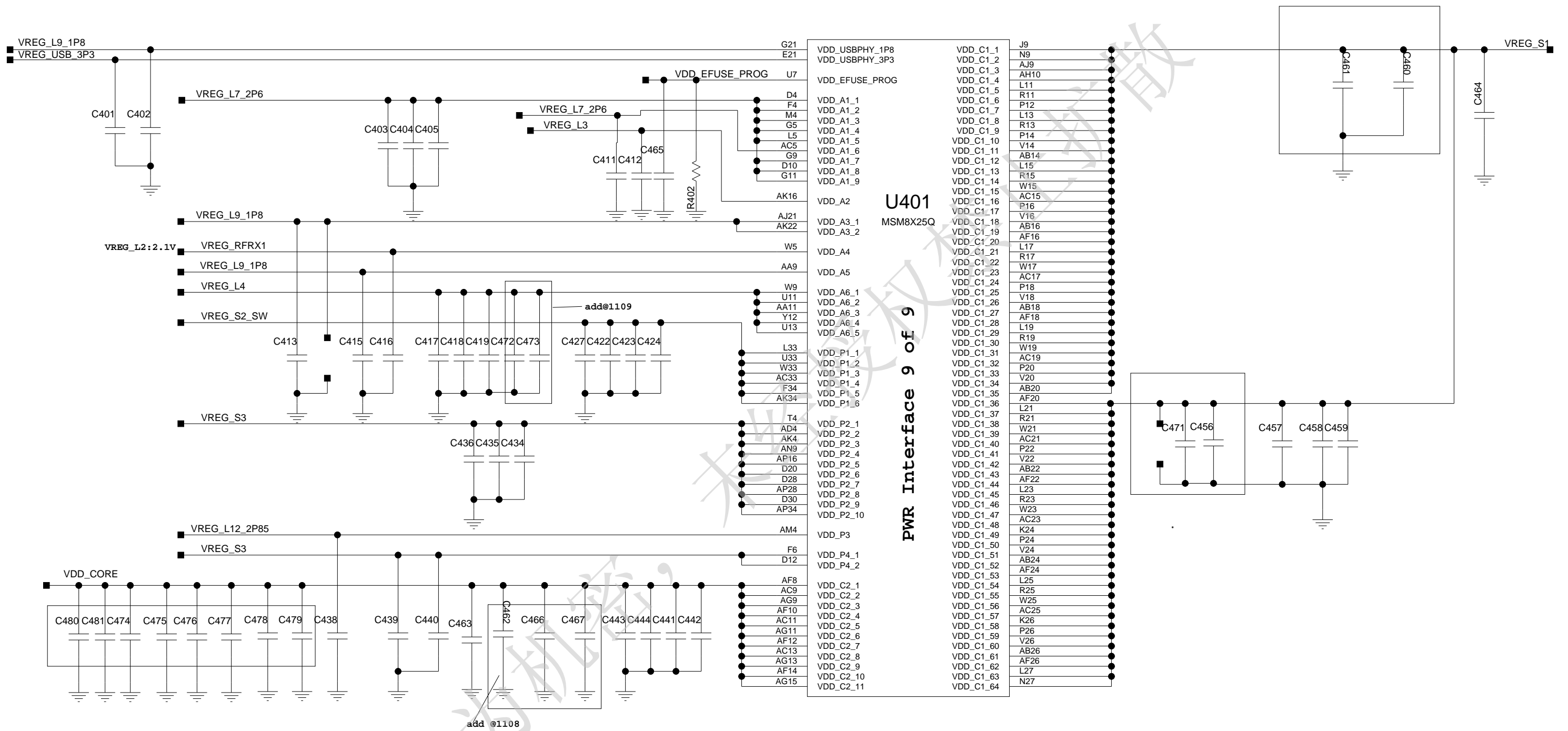

The type and specification of the components refer to the BOM

				NA	
				ECA NO	DATE
DESIGNED	ZHANGSAN XXXXX	HD1G520M		00001234	
REVIEWED	LISI XXXXX	VER	PART_NUMBER	SHEET 4 OF 37	
		A	03030001	HUAWEI TECH CO.,LTD.	



5. MSM8225Q Analog Circuit and RF interface

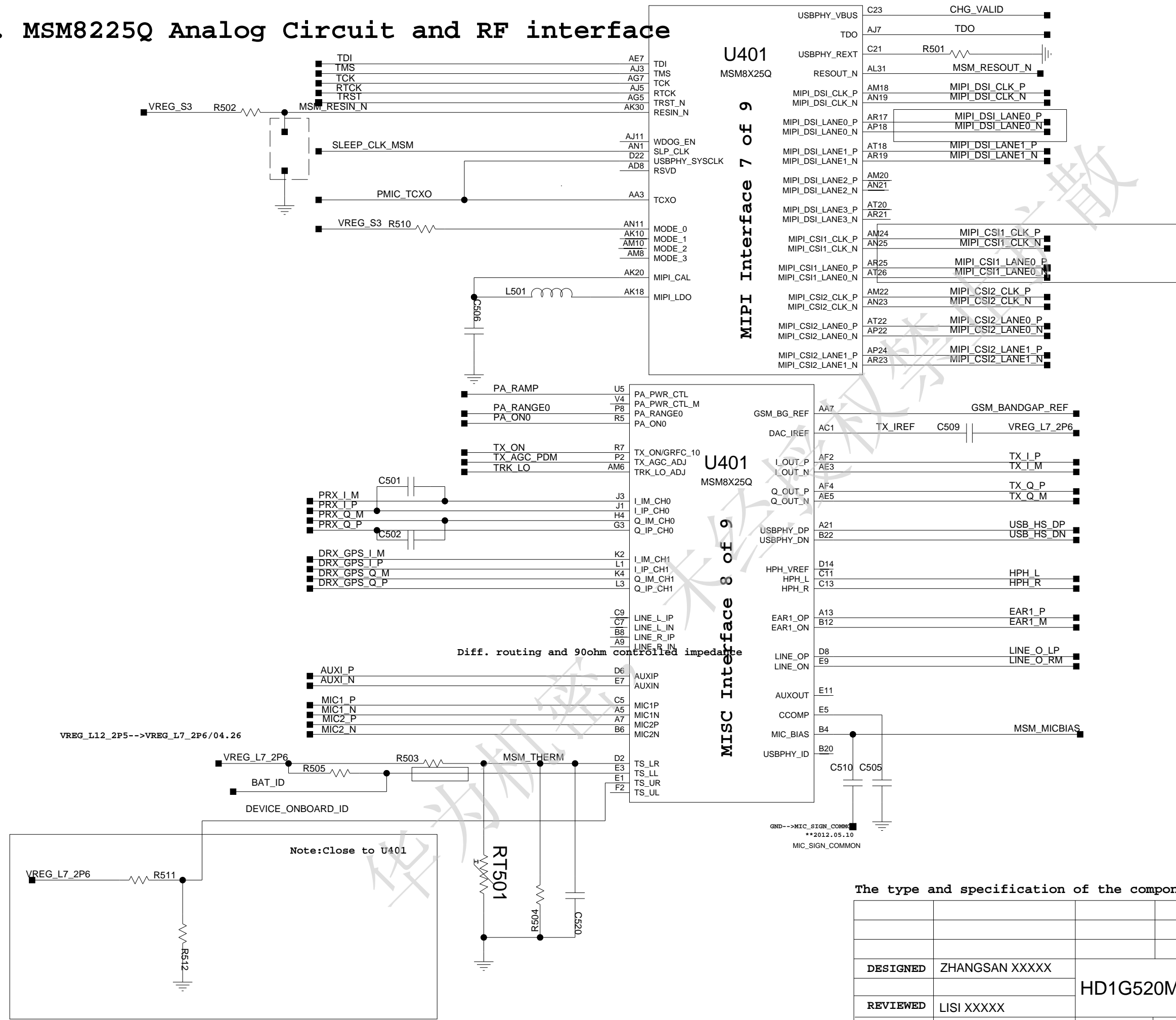

The type and specification of the components refer to the BOM

				NA
			ECA NO	DATE
DESIGNED	ZHANGSAN XXXXX	HD1G520M		00001234
REVIEWED	LISI XXXXX	VER	PART_NUMBER	SHEET 5 OF 37
		A	03030001	HUAWEI TECH CO.,LTD.

6. MSM8225Q MCP interface & GND

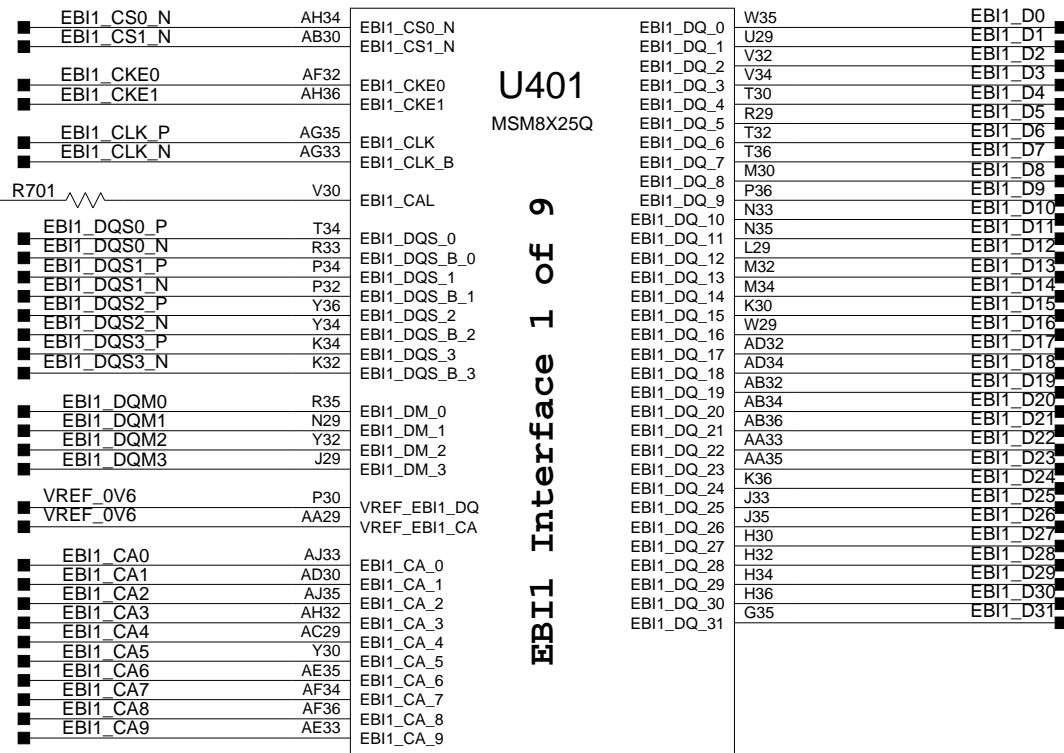

CAD NOTES:
Place resistor close to MSM.

change@10.30

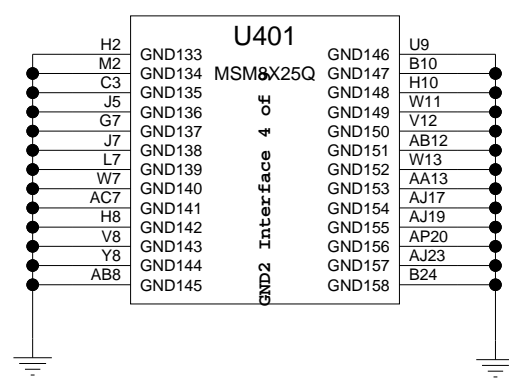
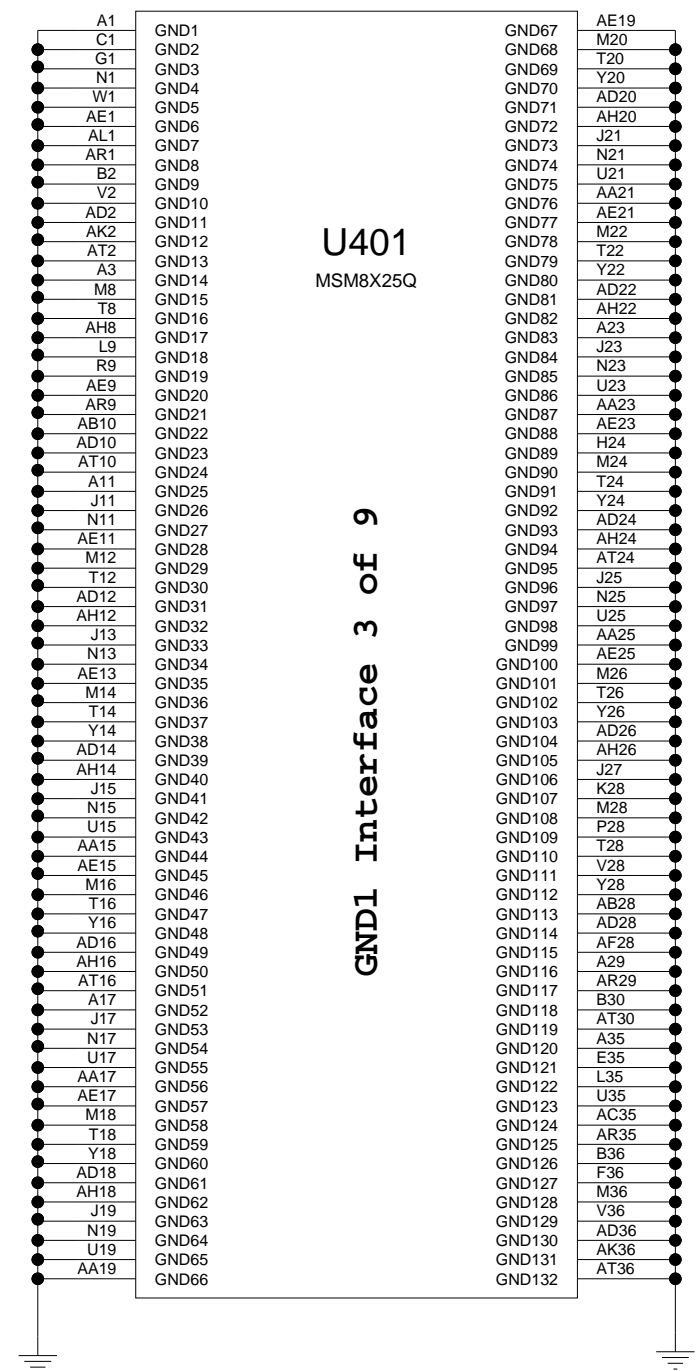
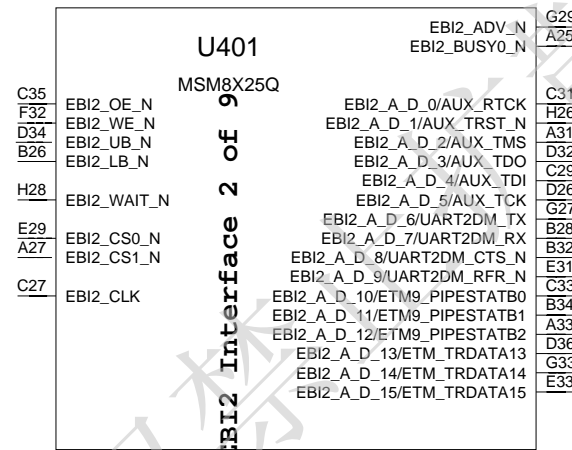

The type and specification of the components refer to the BOM

DESIGNED	ZHANGSAN XXXXX	HD1G520M	00001234
REVIEWED	LISI XXXXX	VER	PART_NUMBER
		A	03030001
			SHEET 6 OF 37
			HUAWEI TECH CO.,LTD.



华为机密

7. MSM8225Q GPIO Data UI and Other Interface

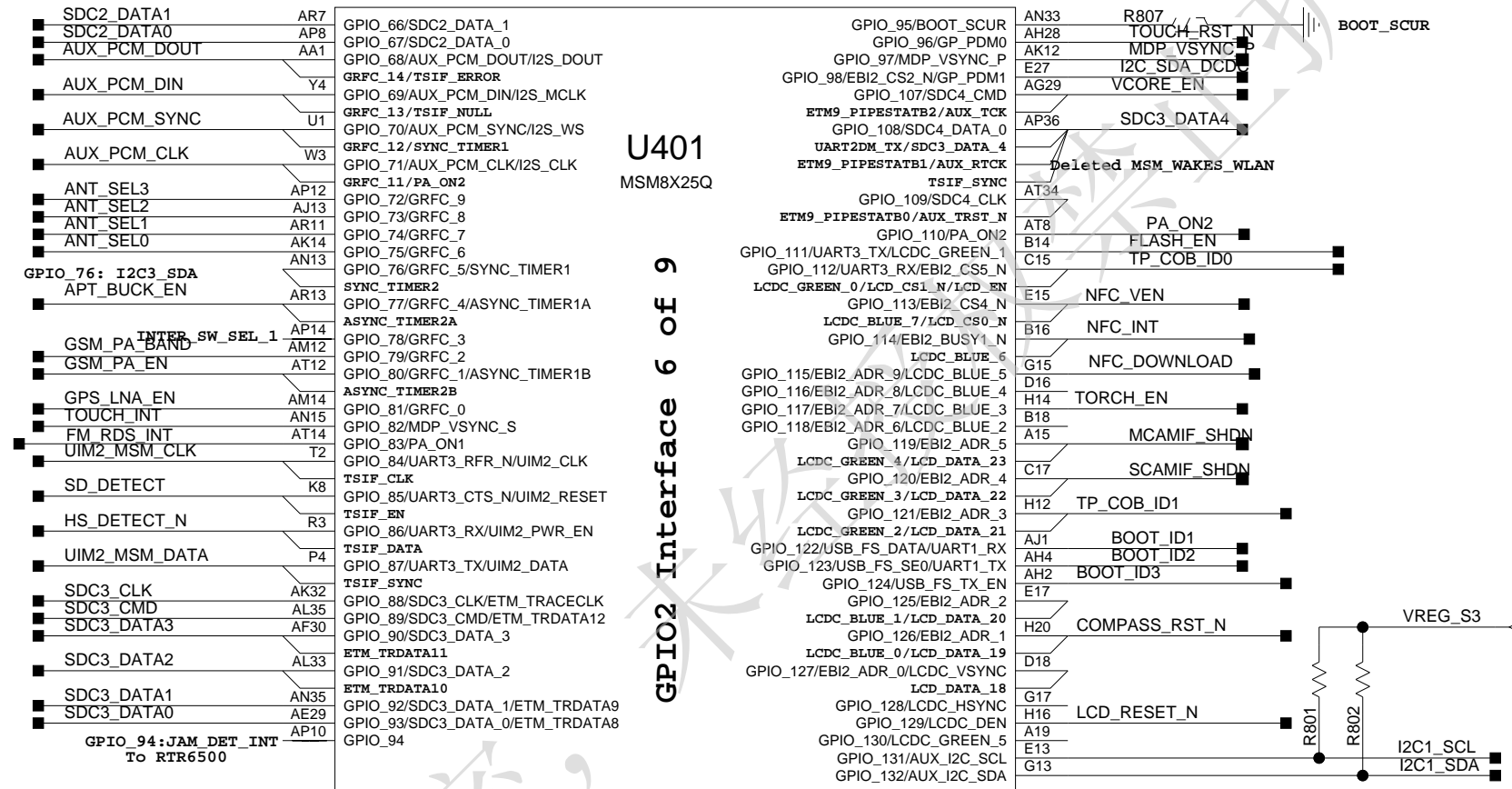

The type and specification of the components refer to the BOM

				NA	
				ECA NO	DATE
DESIGNED	ZHANGSAN XXXXX	HD1G520M		00001234	
REVIEWED	LISI XXXXX	VER	PART_NUMBER	SHEET 7 OF 37	
		A	03030001	HUAWAI TECH CO.,LTD.	

8. MSM8225Q GPIO Data UI and Other Interface

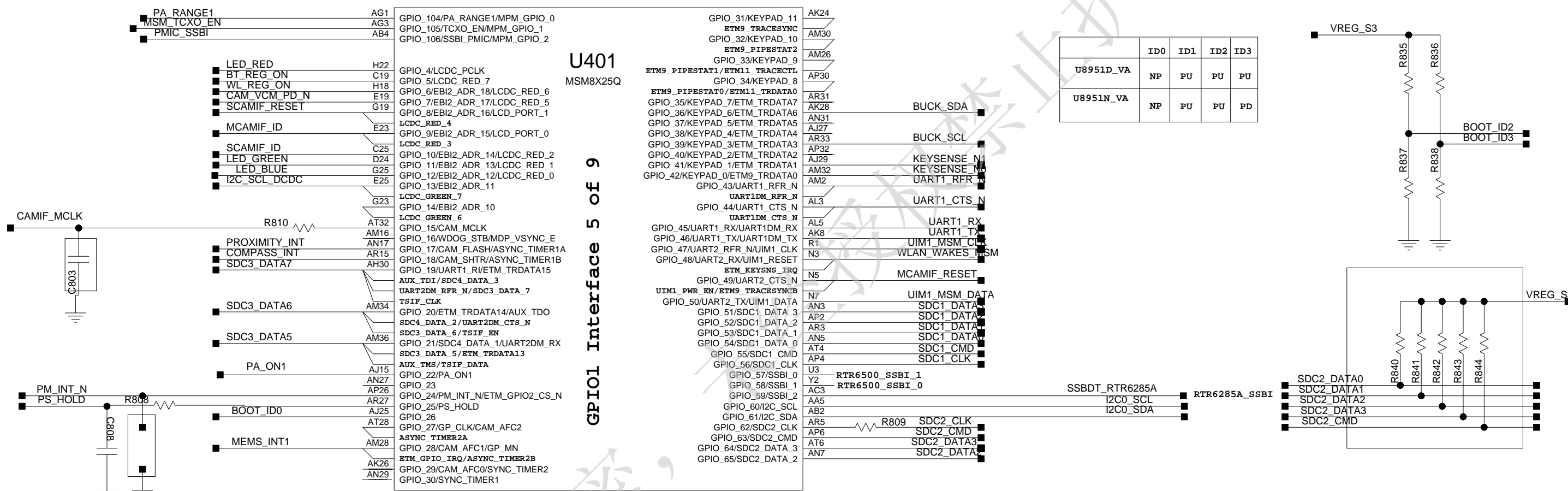

	ID0	ID1	ID2	ID3
U8951D_VA	NP	PU	PU	PU
U8951N_VA	NP	PU	PU	PD

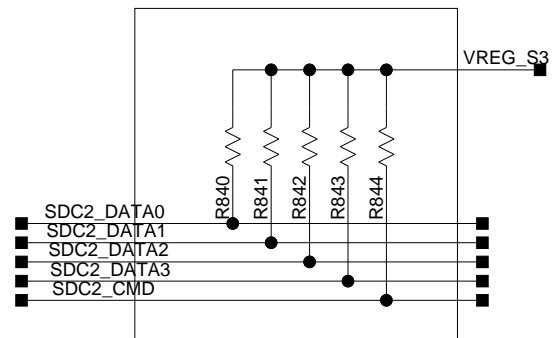
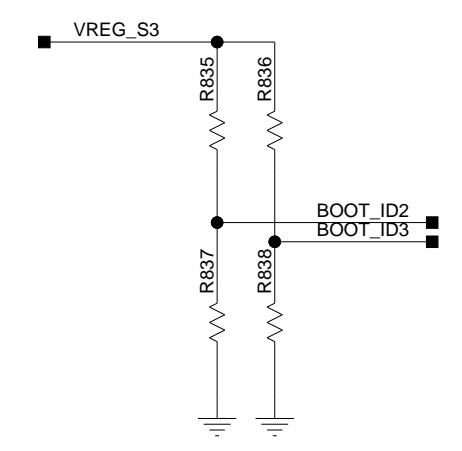
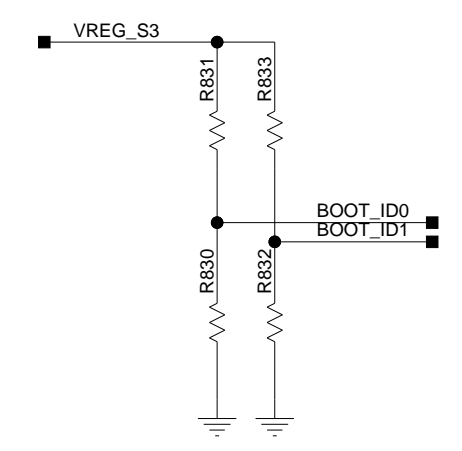

The type and specification of the components refer to the BOM

				NA	
				ECA NO	DATE
DESIGNED	ZHANGSAN XXXXX	HD1G520M		00001234	
REVIEWED	LISI XXXXX	VER	PART_NUMBER	SHEET 8 OF 37	
		A	03030001	HUAWEI TECH CO.,LTD.	

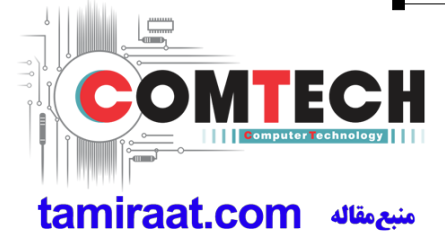

10. Main Camera and Slave Camera

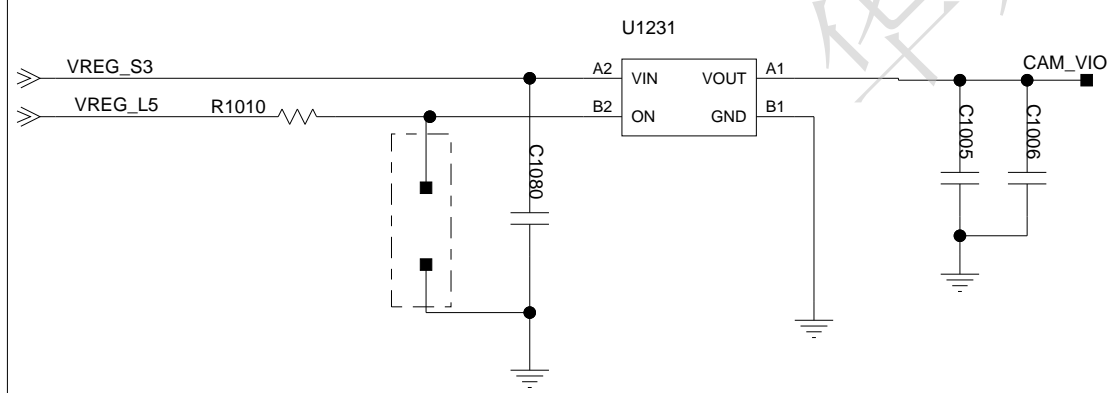
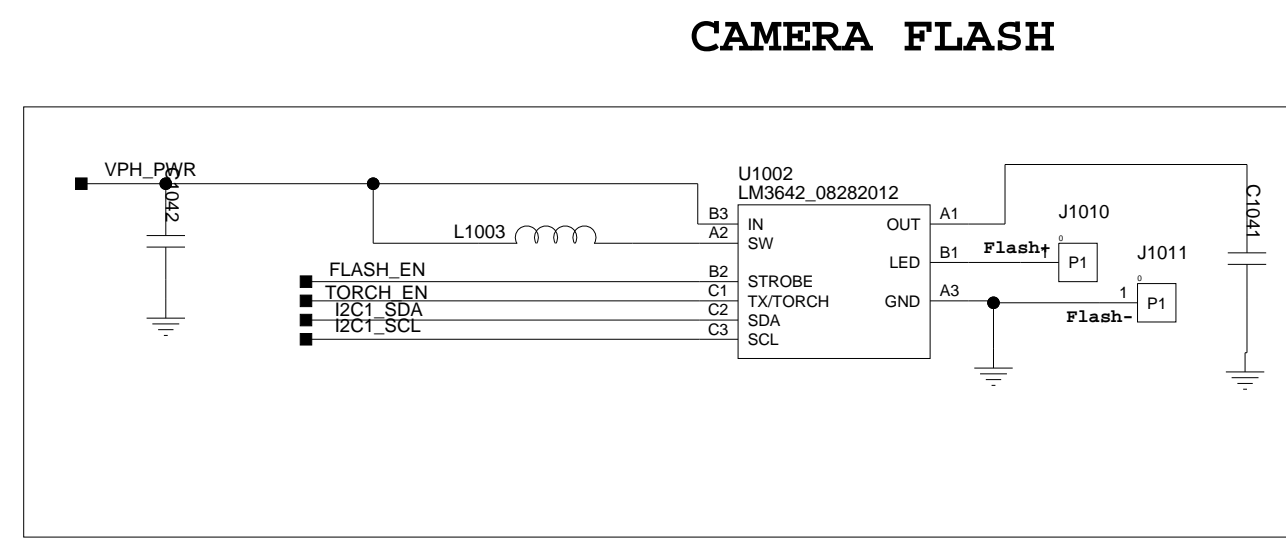
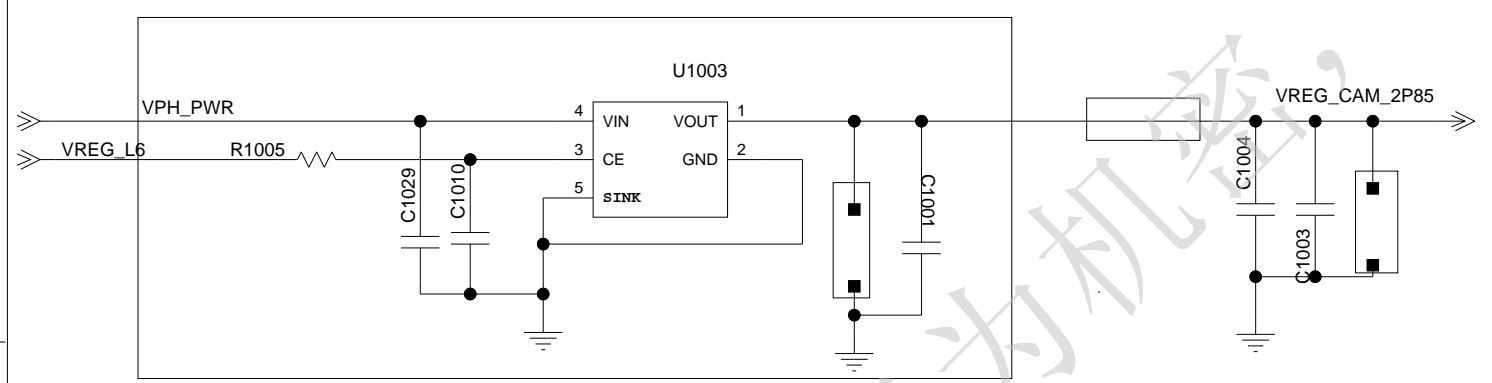
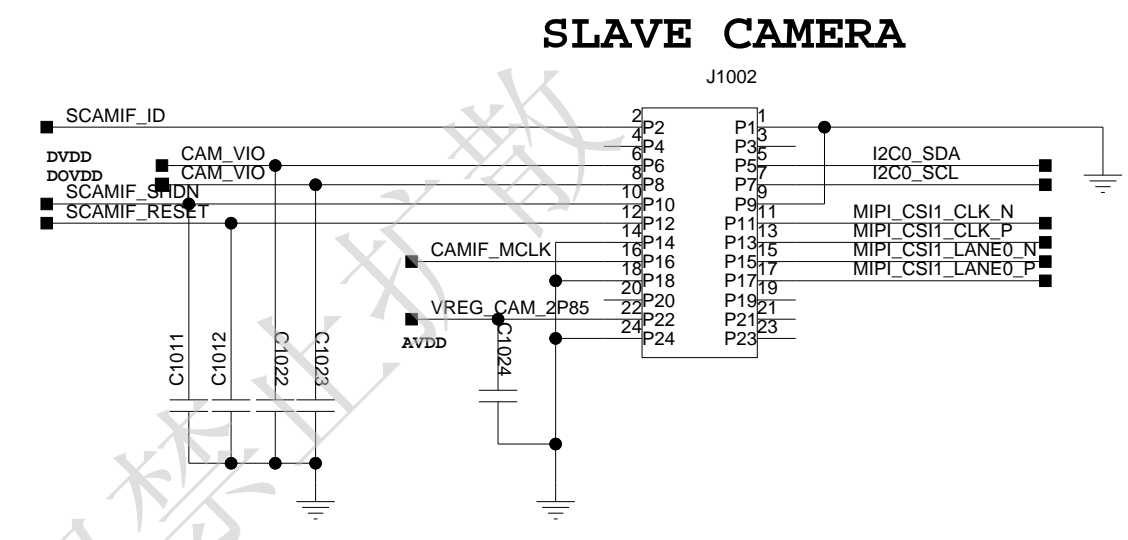
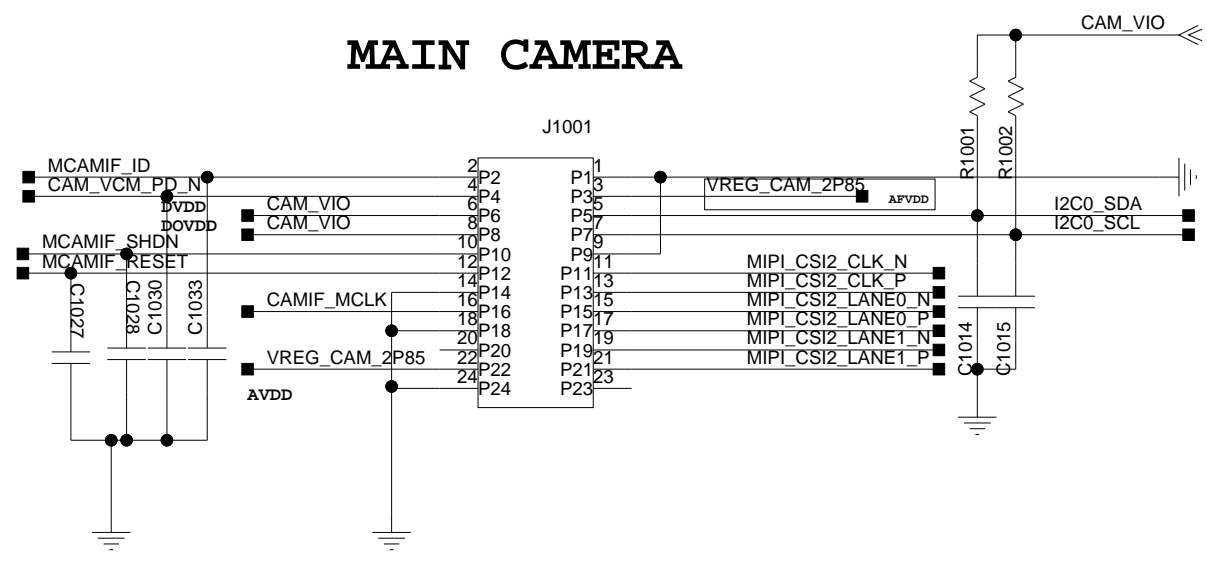

The type and specification of the components refer to the BOM

DESIGNED	ZHANGSAN XXXXX	HD1G520M	NA
REVIEWED	LISI XXXXX	00001234	ECA NO DATE
		VER	PART_NUMBER
		A	03030001
			SHEET 10 OF 37
			HUAWEI TECH CO.,LTD.

11. 3.5 Headphone port

HTC headset: MIC and GND changed.

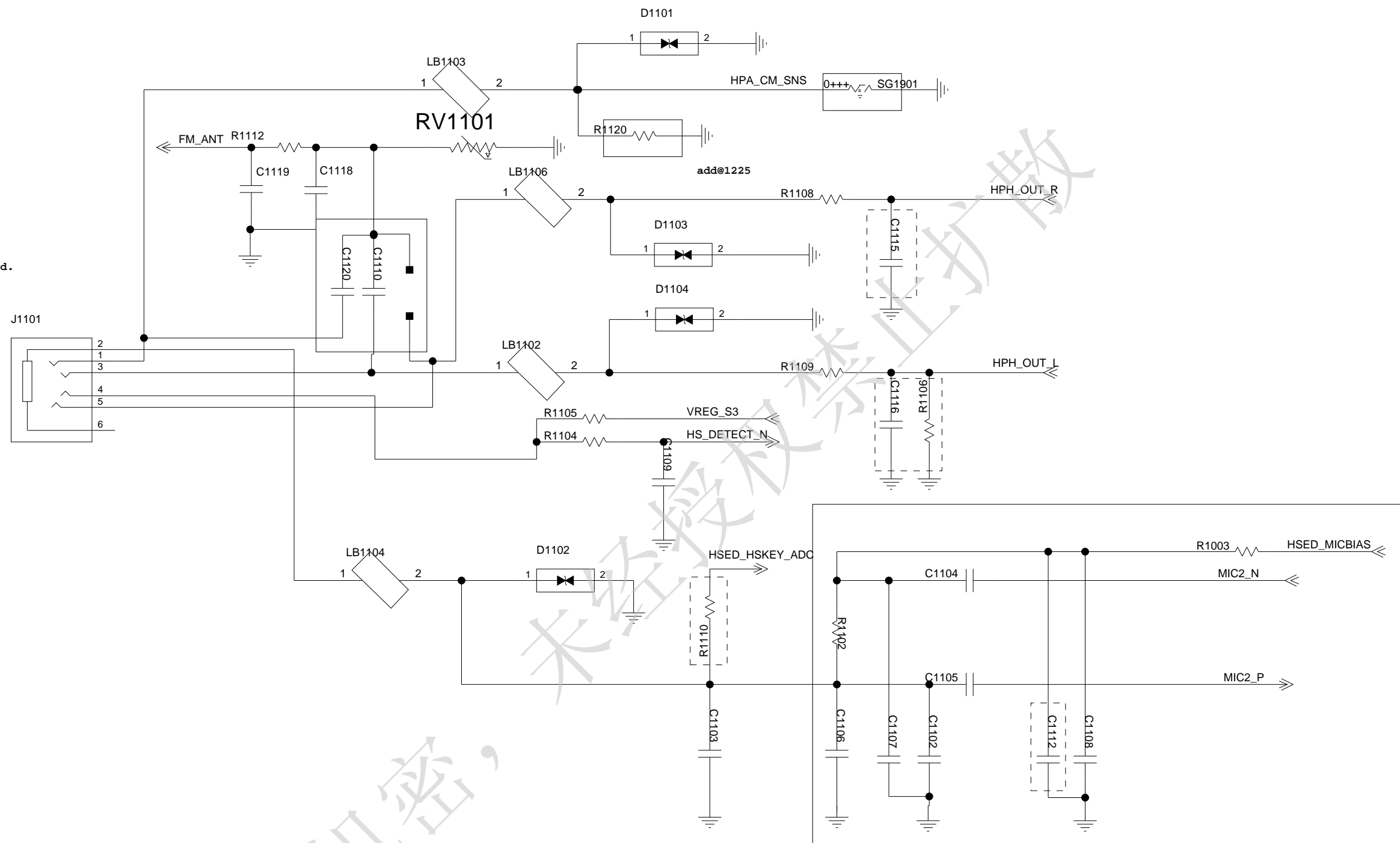

The type and specification of the components refer to the BOM

				NA	
				ECA NO	DATE
DESIGNED	ZHANGSAN XXXXX	HD1G520M		00001234	
REVIEWED	LISI XXXXX	VER	PART_NUMBER	SHEET 11 OF 37	
		A	03030001	HUAWEI TECH CO.,LTD.	

12. Sensor/Status indicator

Accelerometer

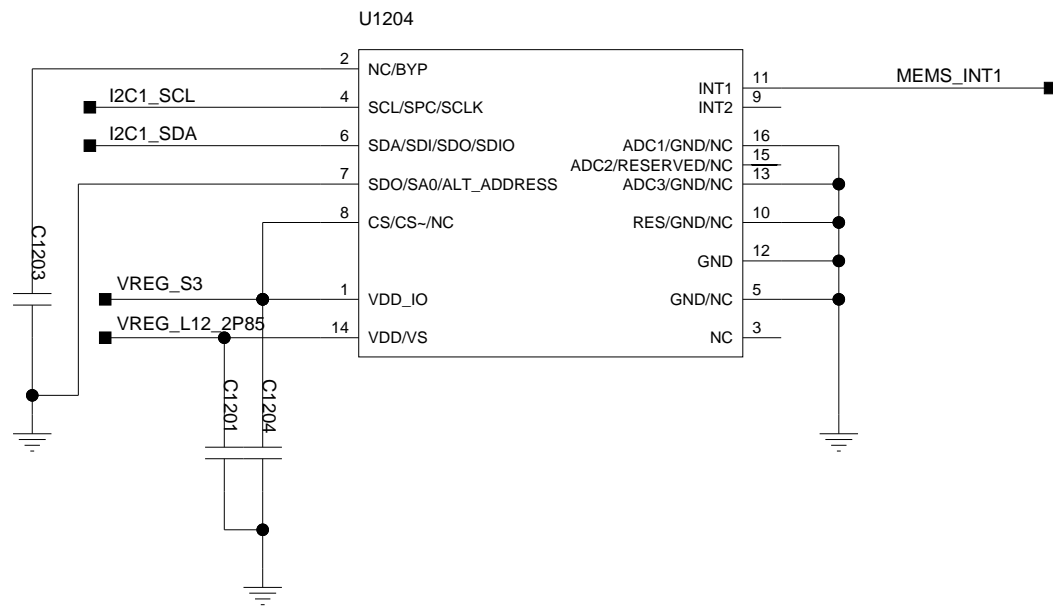

Ambient Light and Proximity

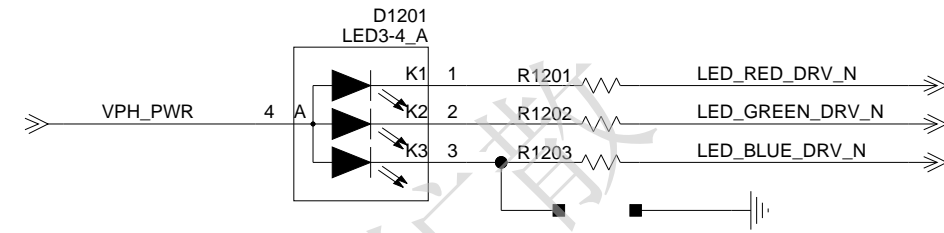

Status Indicator

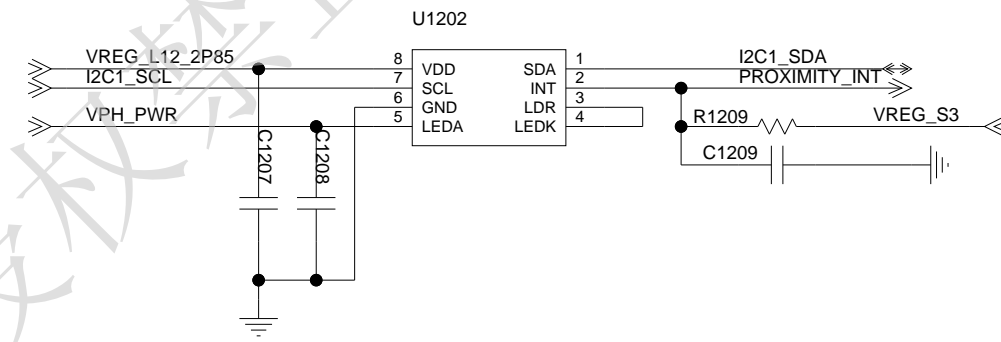

Compass-AK8963C

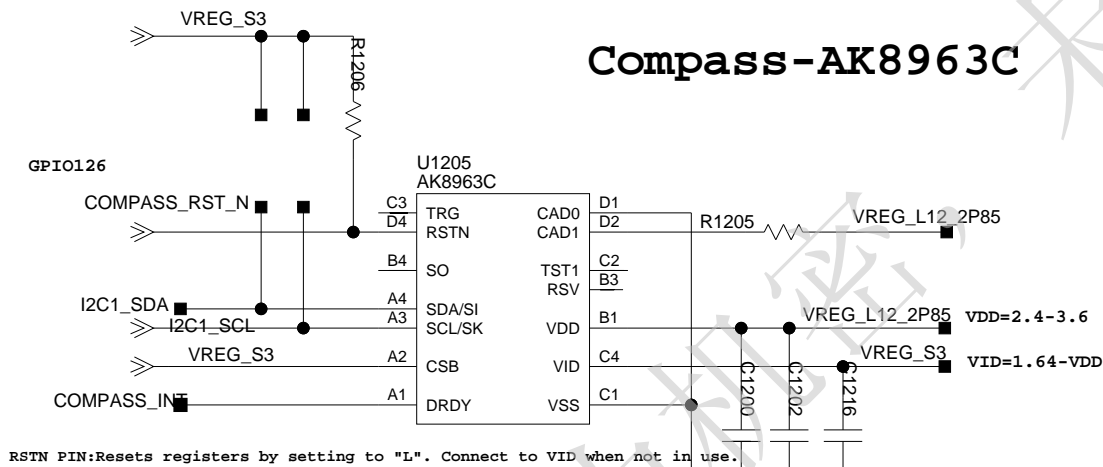

The type and specification of the components refer to the BOM

				NA	
				ECA NO	DATE
DESIGNED	ZHANGSAN XXXXX	HD1G520M		00001234	
REVIEWED	LISI XXXXX	VER	PART_NUMBER	SHEET 12 OF 37	
		A	03030001	HUAWAI TECH CO.,LTD.	

13. LCD interface & LCD backlight driver

LCD 24pinBTB(4.0' MIPI 2 LANE)

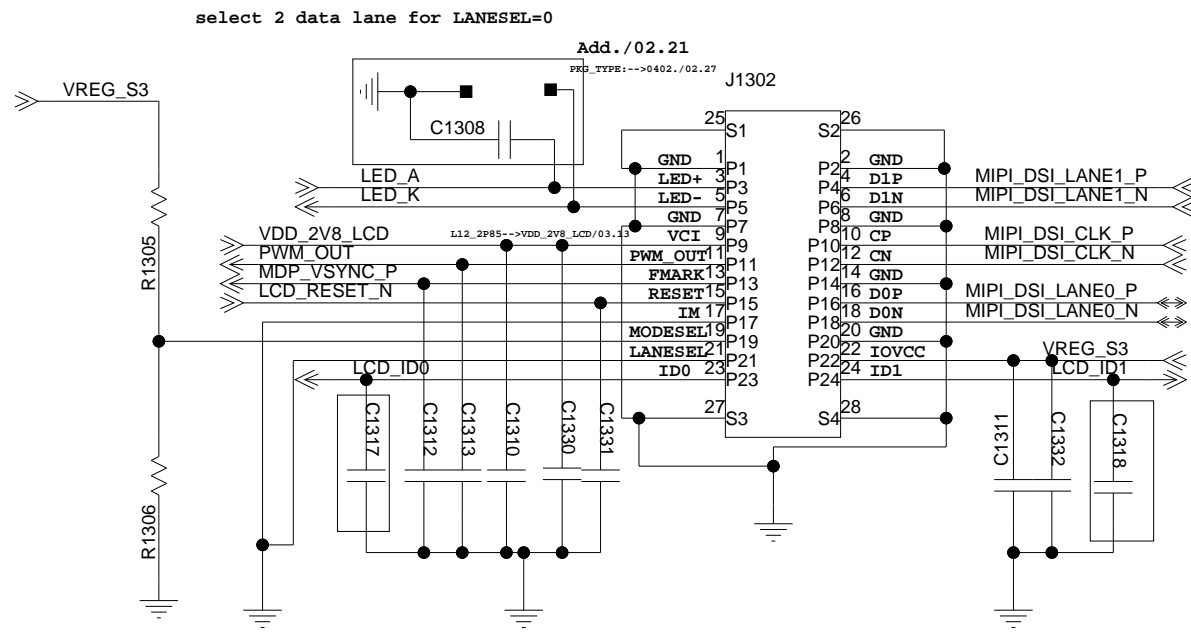

LCM backlight driver

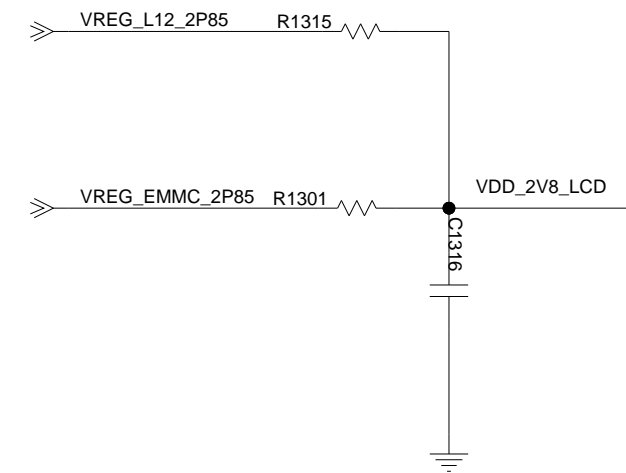
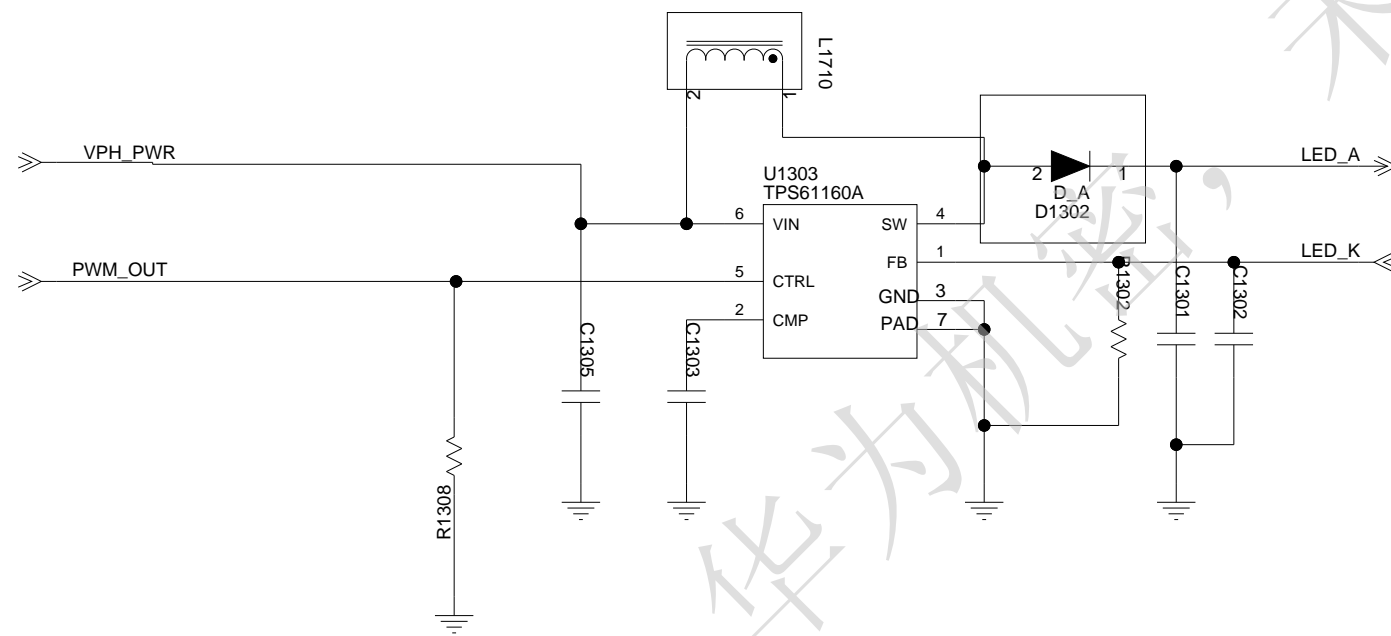

The type and specification of the components refer to the BOM

				NA	
				ECA NO	DATE
DESIGNED	ZHANGSAN XXXXX	HD1G520M		00001234	
REVIEWED	LISI XXXXX	VER	PART_NUMBER	SHEET 13 OF 37	
		A	03030001	HUAWEI TECH CO.,LTD.	

14. SIM/TF card

TF Card

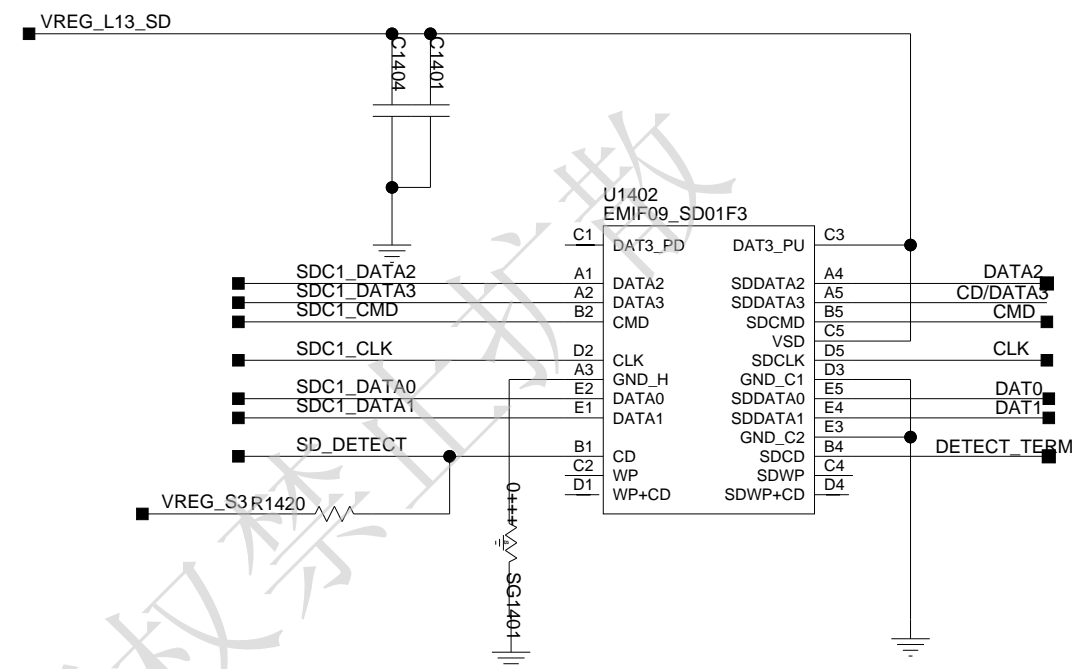

SIM Card ESD Protect

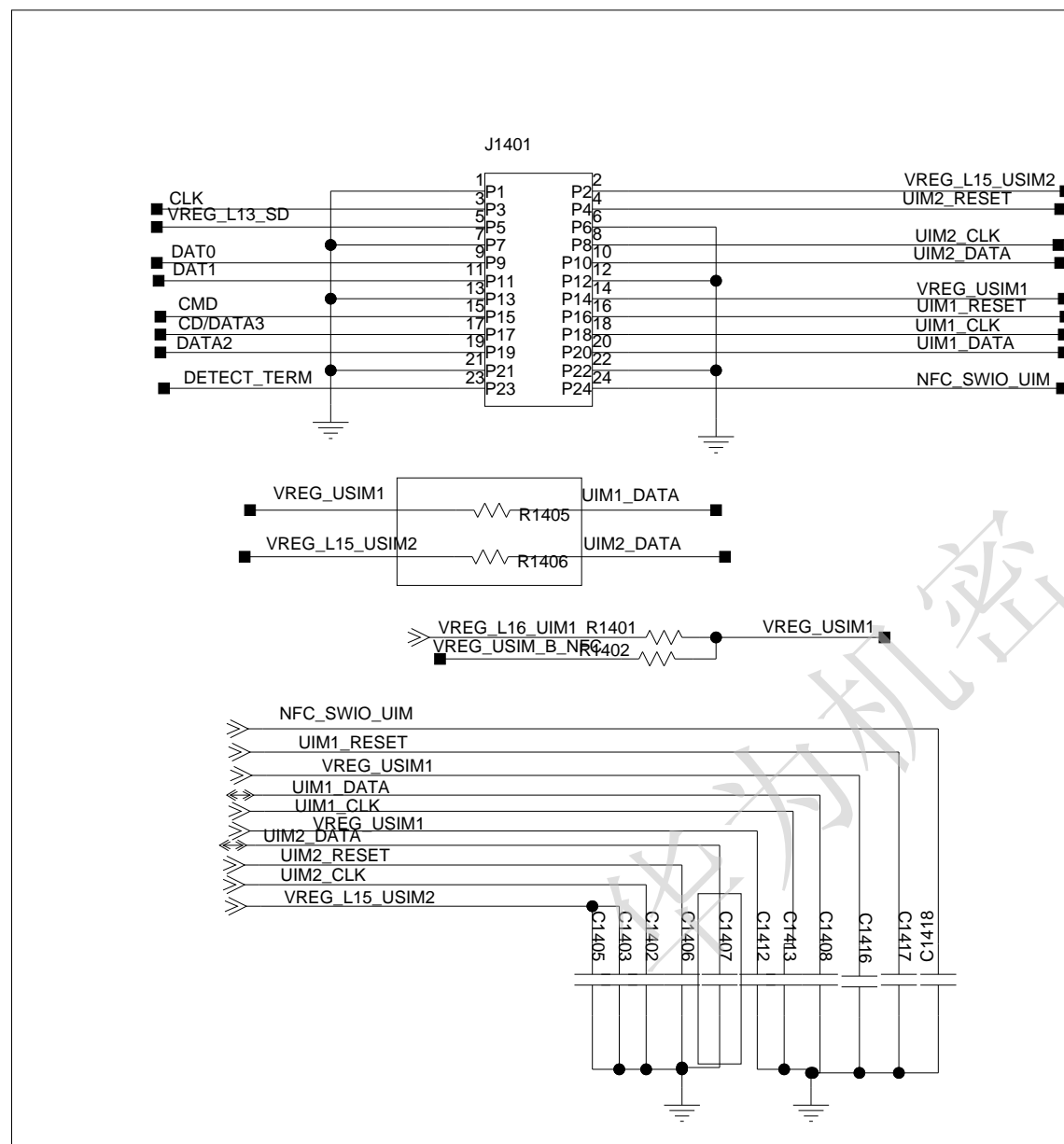
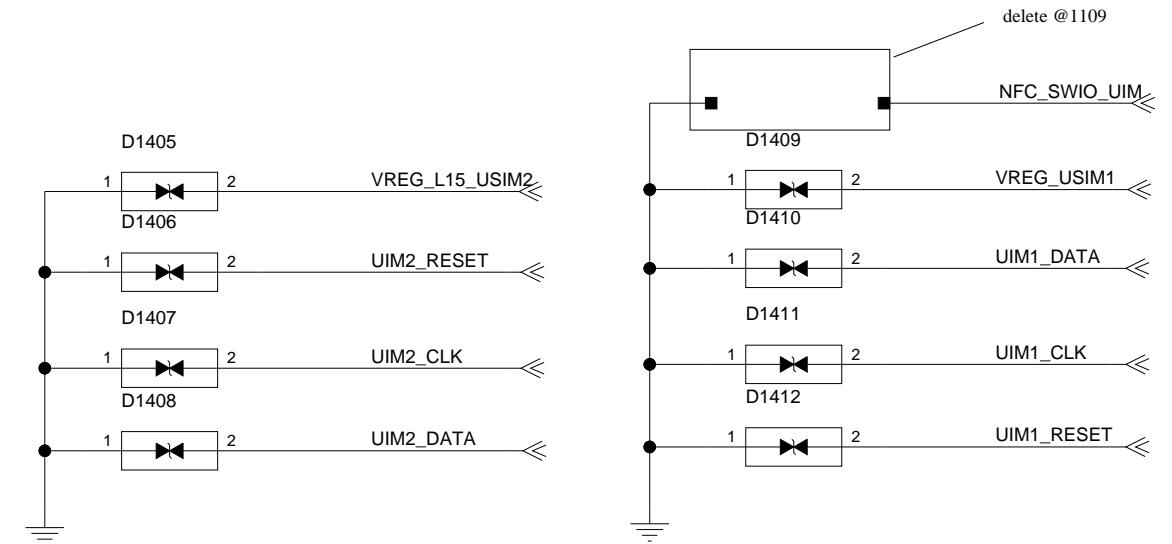

The type and specification of the components refer to the BOM

				NA	
				ECA NO	DATE
DESIGNED	ZHANGSAN XXXXX	HD1G520M		00001234	
REVIEWED	LISI XXXXX	VER	PART_NUMBER	SHEET 14 OF 37	
		A	03030001	HUAWEI TECH CO.,LTD.	

15. AUDIO/MIC

Primary Mic

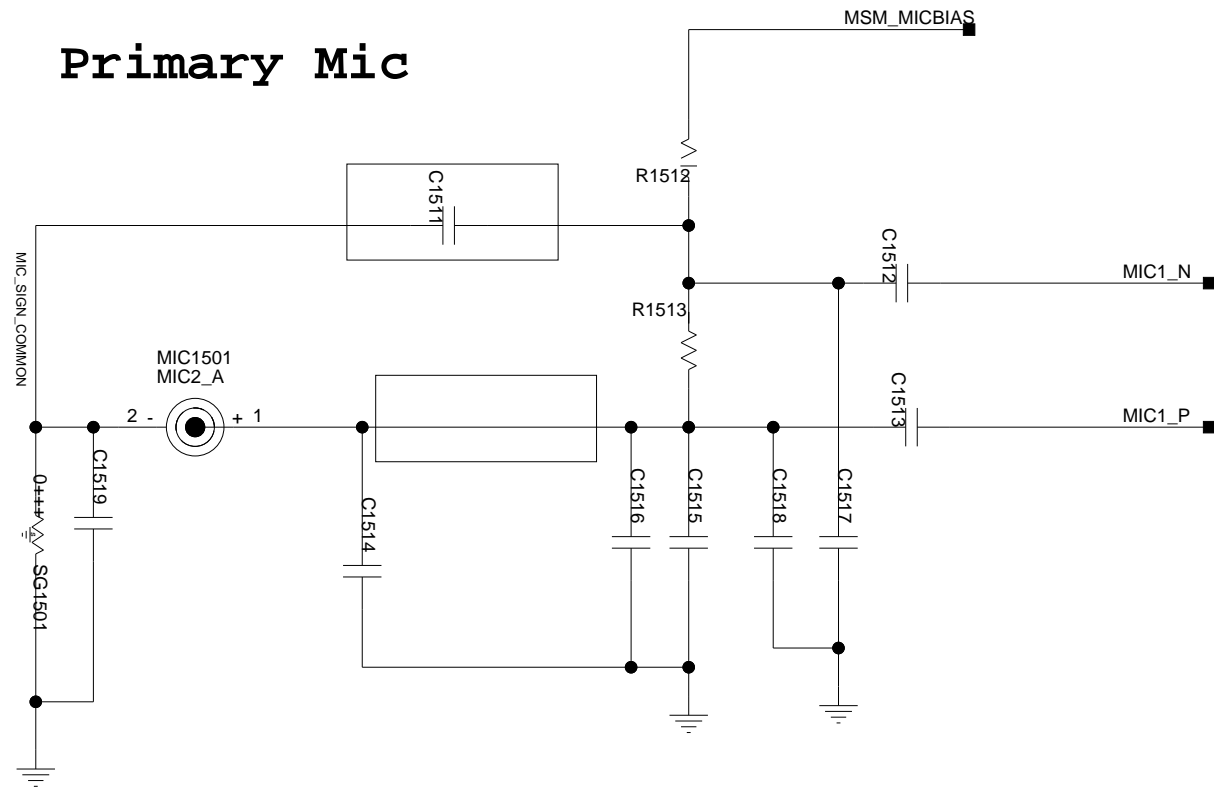

Secondary Mic

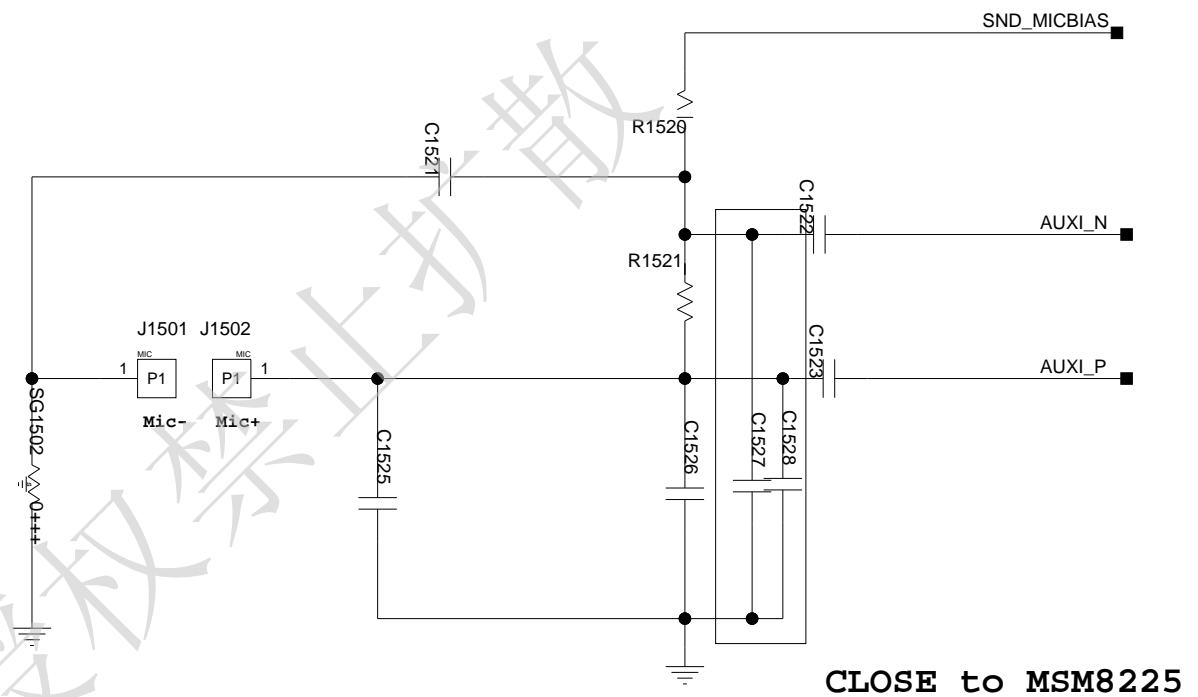

Speaker

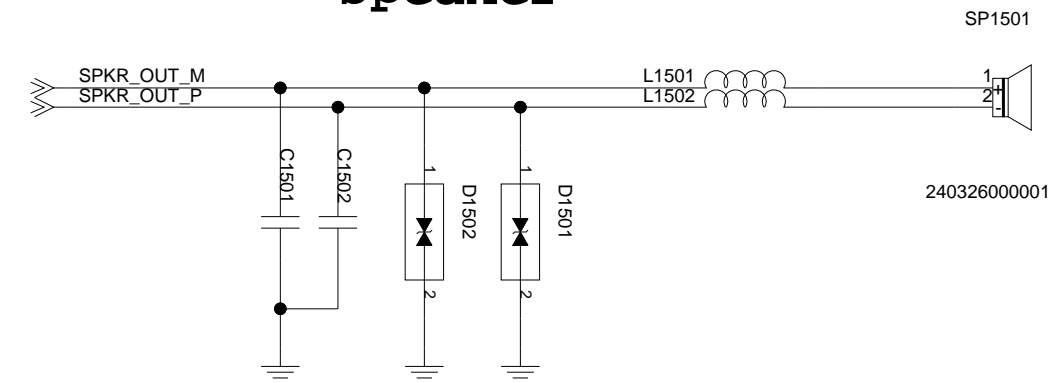

For different vendor different wire direction

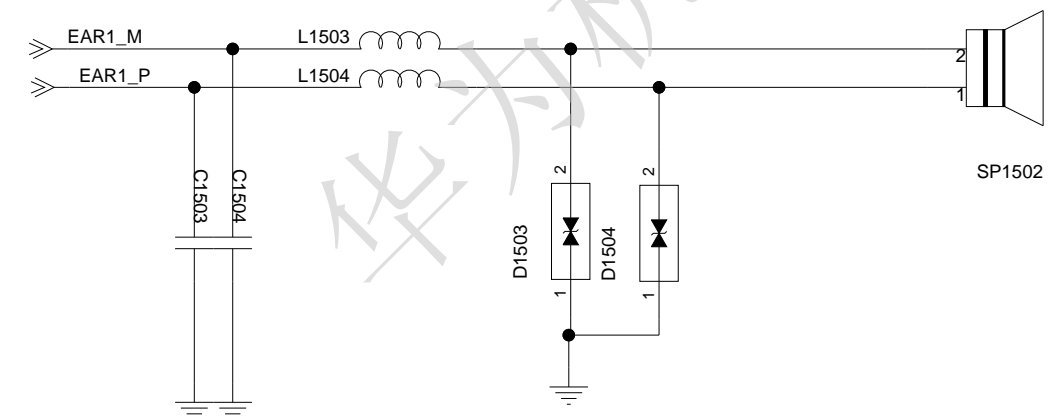

The type and specification of the components refer to the BOM

				NA
			ECA NO	DATE
DESIGNED	ZHANGSAN XXXXX	HD1G520M		00001234
REVIEWED	LISI XXXXX	VER	PART_NUMBER	SHEET 15 OF 37
		A	03030001	HUAWEI TECH CO.,LTD.



16. Keypad/Touch/indicator

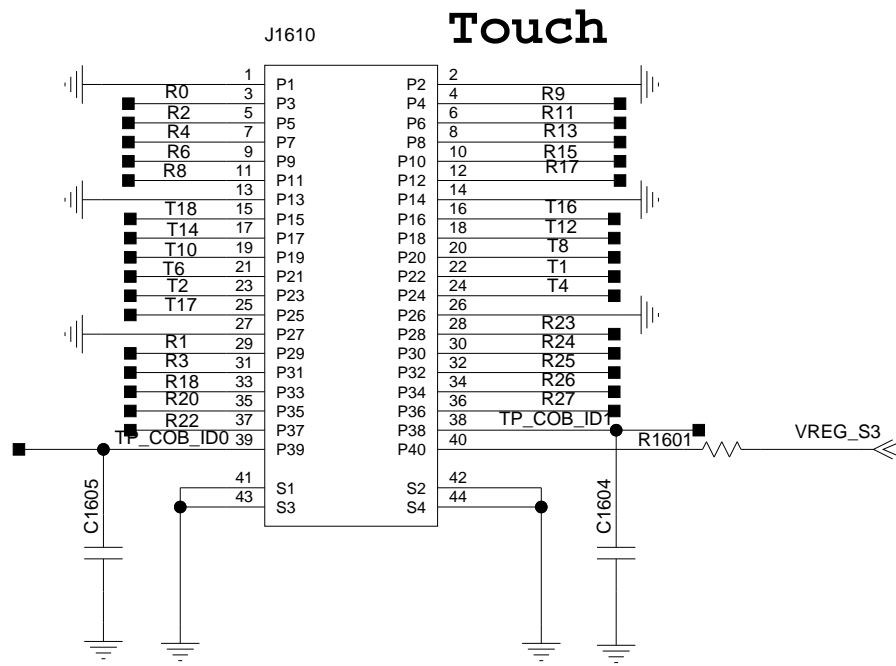

TOUCH

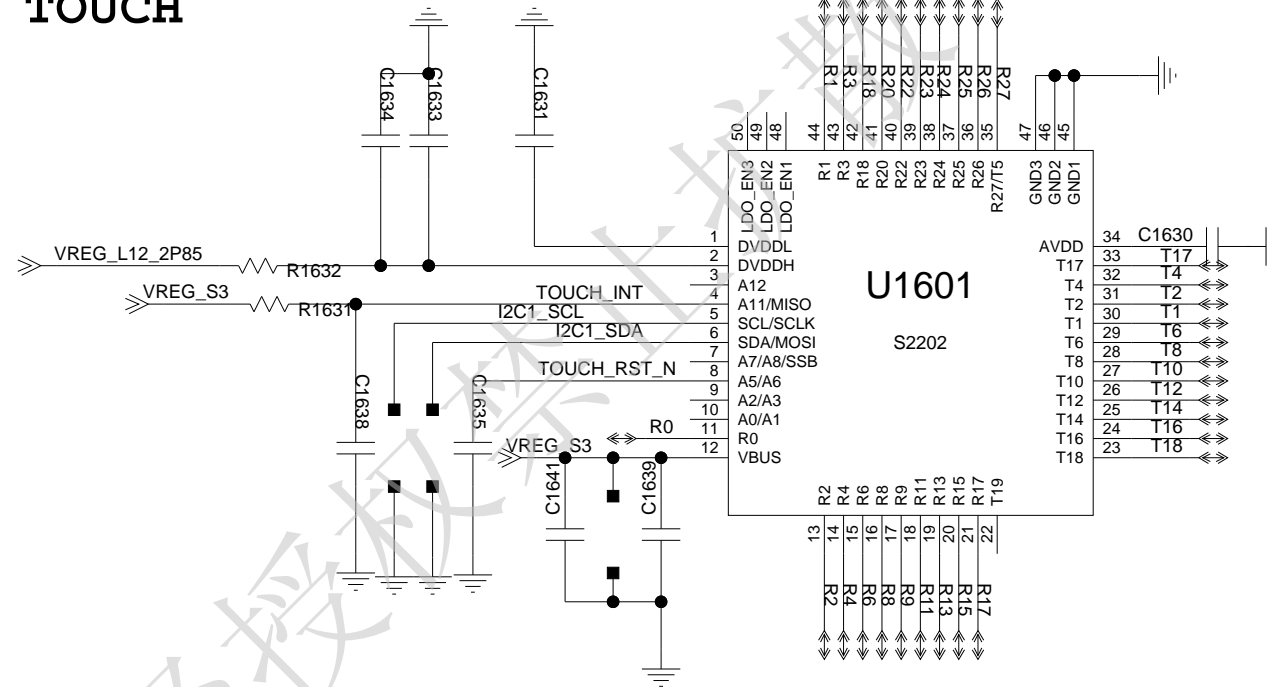

Volume&Power Key

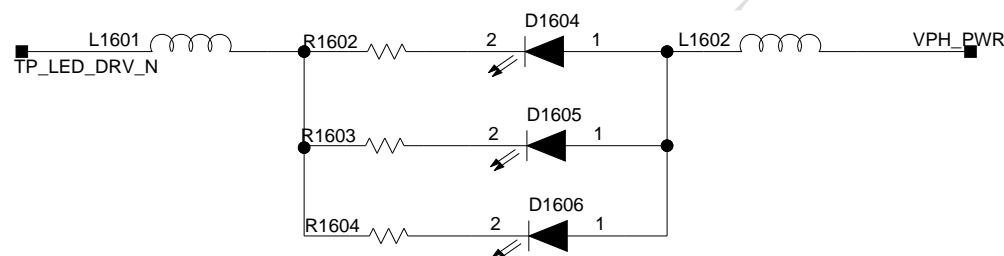
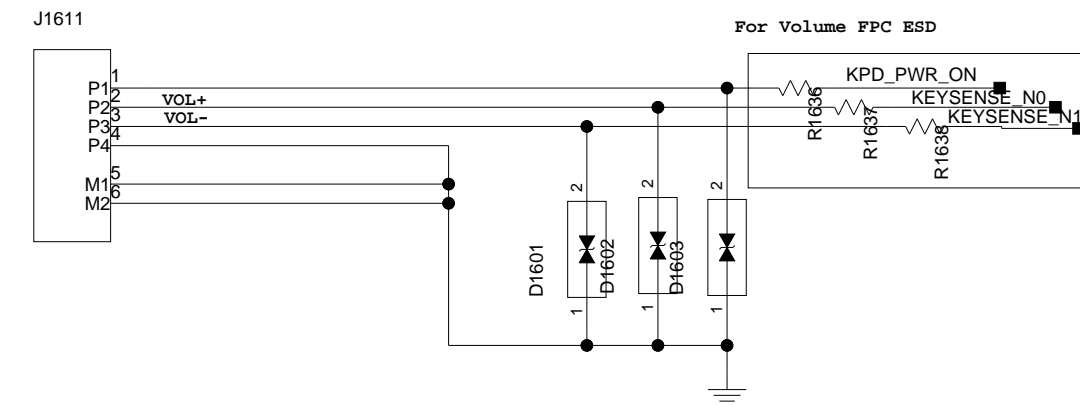

The type and specification of the components refer to the BOM

DESIGNED	ZHANGSAN XXXXX	HD1G520M	00001234
REVIEWED	LISI XXXXX	VER	PART_NUMBER
		A	03030001
			SHEET 16 OF 37
			HUAWEI TECH CO.,LTD.

17. Test Points/JTAG/Shields

TEST POINT for CT and BT

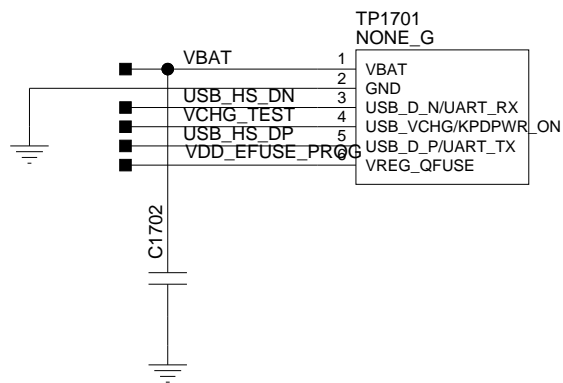

Shielding

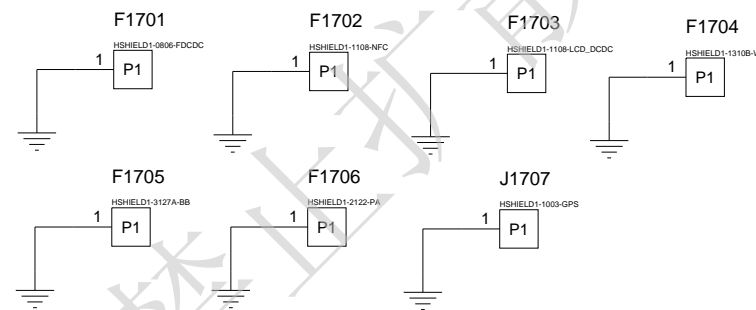

JTAG

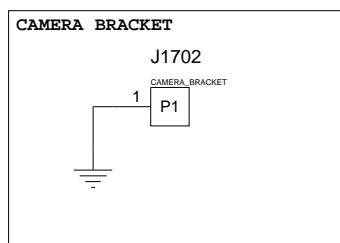
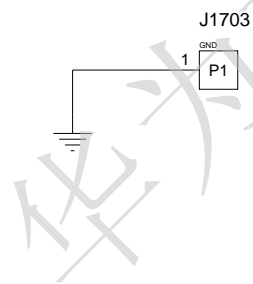
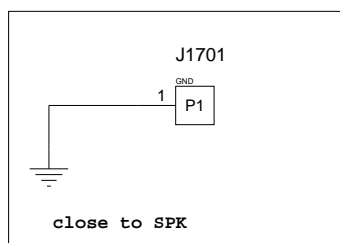
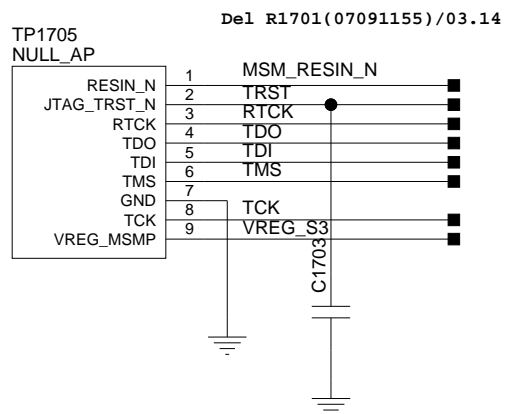

The type and specification of the components refer to the BOM

				NA	
				ECA NO	DATE
DESIGNED	ZHANGSAN XXXXX	HD1G520M		00001234	
REVIEWED	LISI XXXXX	VER	PART_NUMBER	SHEET 17 OF 37	
		A	03030001	HUAWEI TECH CO.,LTD.	

18. eMMC+LPDDR2 MCP Circuit

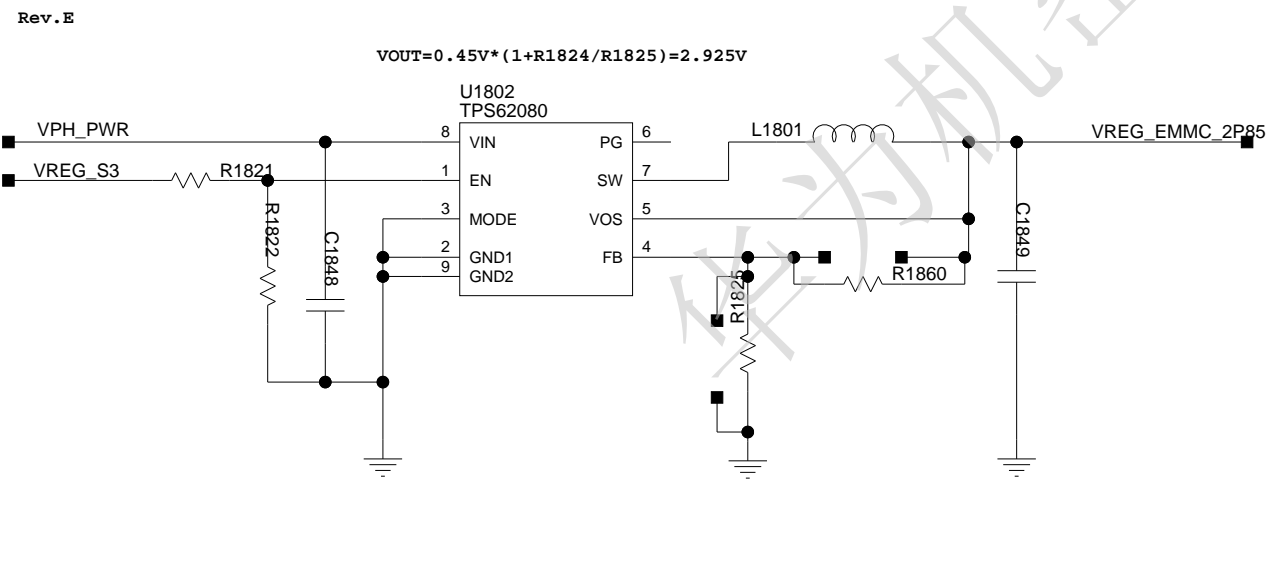
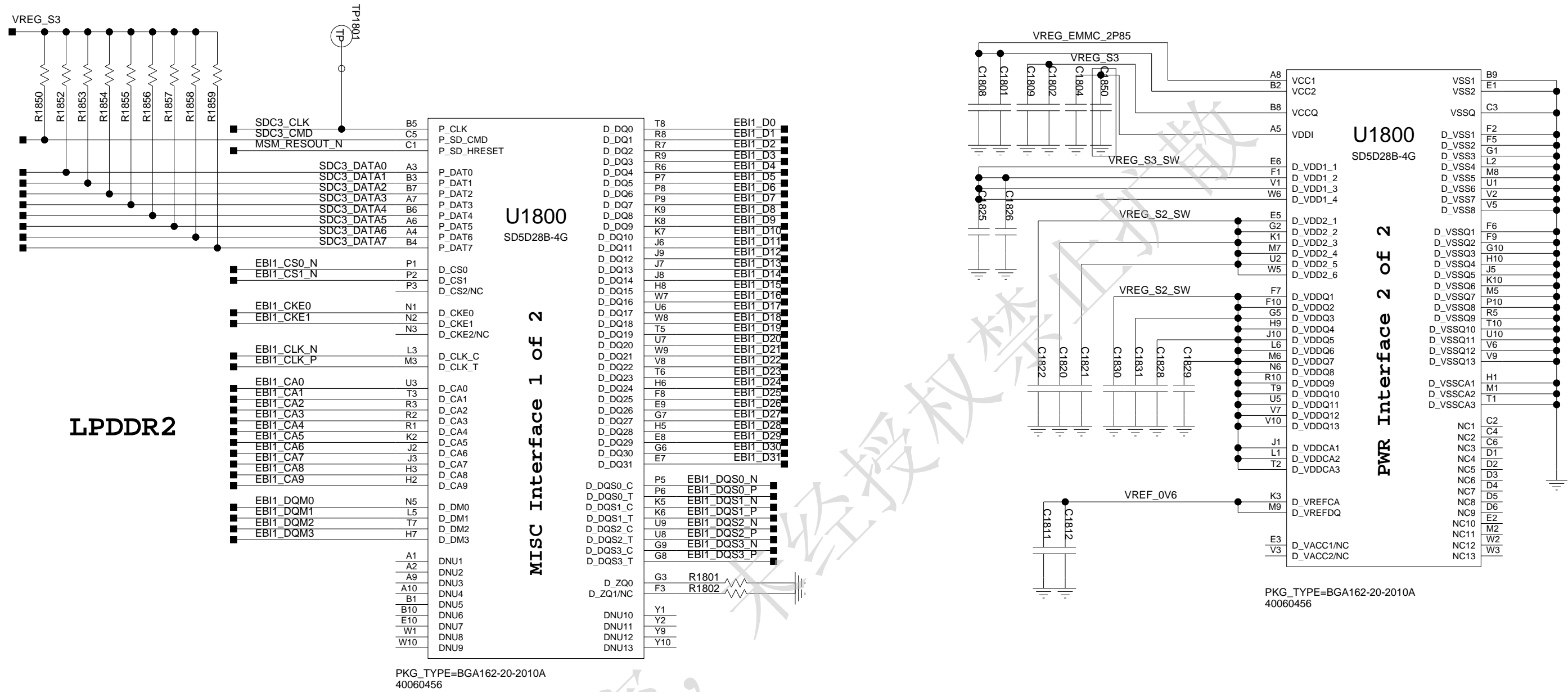

The type and specification of the components refer to the BOM

				NA
			ECA NO	DATE
DESIGNED	ZHANGSAN XXXXX	HD1G520M		00001234
REVIEWED	LISI XXXXX	VER	PART_NUMBER	SHEET 18 OF 37
		A	03030001	HUAWEI TECH CO.,LTD.

19. Power Map

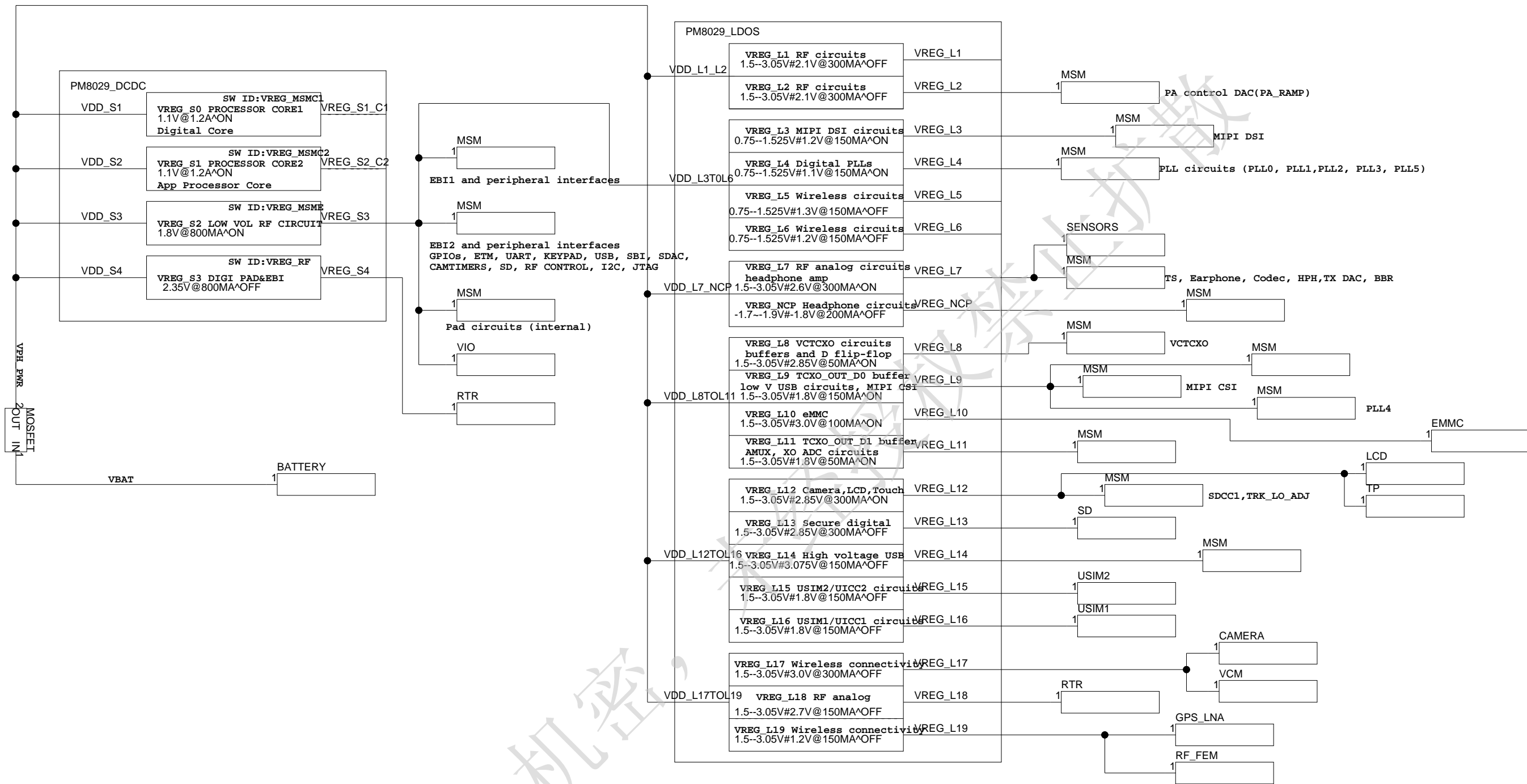

The type and specification of the components refer to the BOM

				NA	
				ECA NO	DATE
DESIGNED	ZHANGSAN XXXXX	HD1G520M		00001234	
REVIEWED	LISI XXXXX	VER	PART_NUMBER	SHEET 19 OF 37	
		A	03030001	HUAWAI TECH CO.,LTD.	

华为机密

20. DCDC FOR RF PA

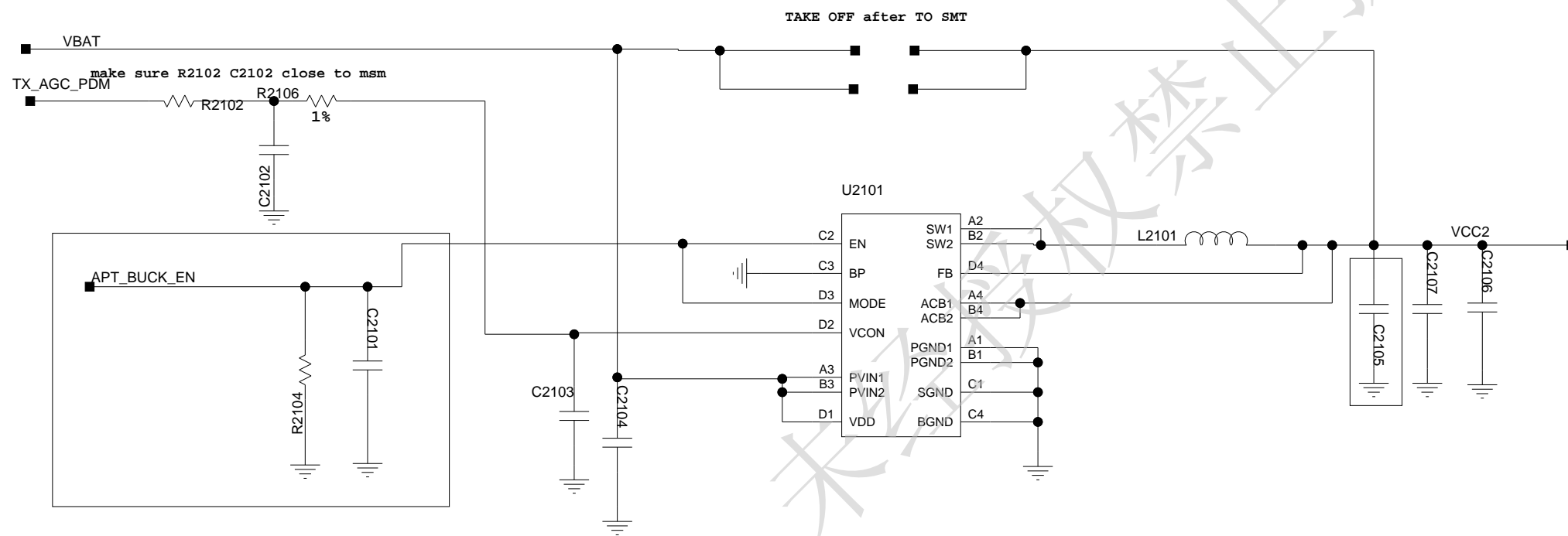

The type and specification of the components refer to the BOM

				NA	
				ECA NO	DATE
DESIGNED	ZHANGSAN XXXXX	HD1G520M		00001234	
REVIEWED	LISI XXXXX	VER	PART_NUMBER	SHEET 20 OF 37	
		A	03030001	HUAWEI TECH CO.,LTD.	

21. RF INPUT OUPUT PORTS

- 20. DCDC For RF PA
- 21. RF Input Output Ports
- 22. 19.2MHz VCTCXO
- 23. Antenna Switchplexer

- 24. WCDMA IMT Power Amplifier
- 25. WCDMA CELL Power Amplifier
- 26. GSM Quad_band_PA
- 27. RX MATCHING CIRCUIT
- 28. UMTS IMT RX INTERSTAGE CHAIN
- 29. RTR6285A CIRCUIT
- 30. RTR6285A POWER DISTRIBUTION
- 31. GPS

- 32. WCDMA PCS Power Amplifier
- 33. NA
- 34. NFC
- 35. BT FM WCN2243
- 36. AR6005 BB
- 37. AR6005 RF

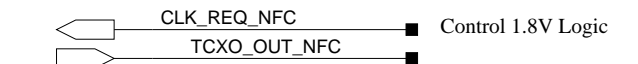
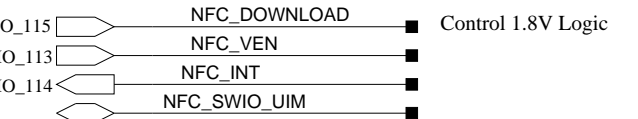
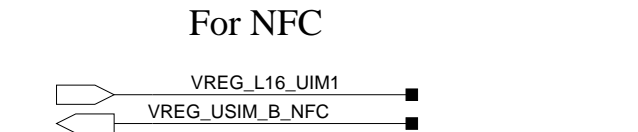
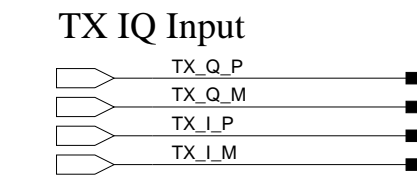
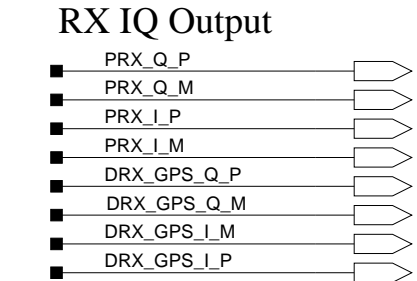
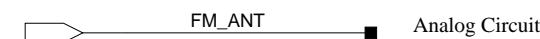
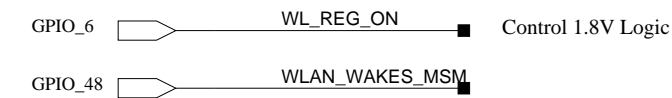
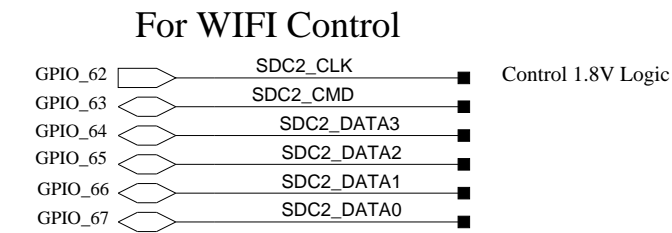
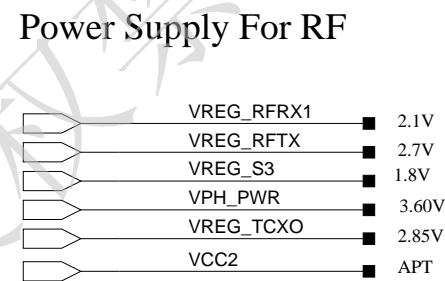
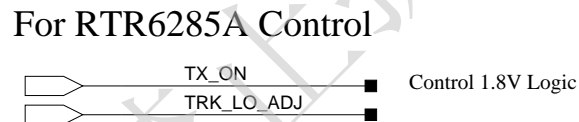
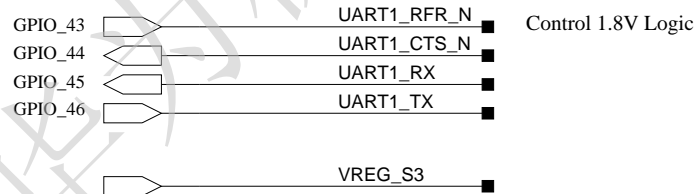
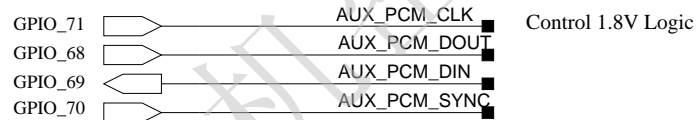
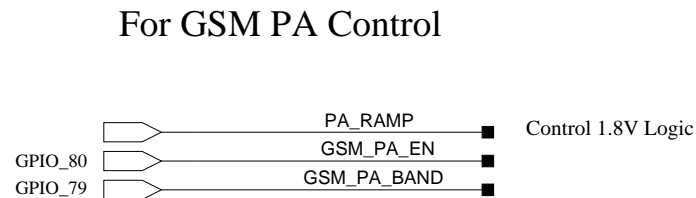
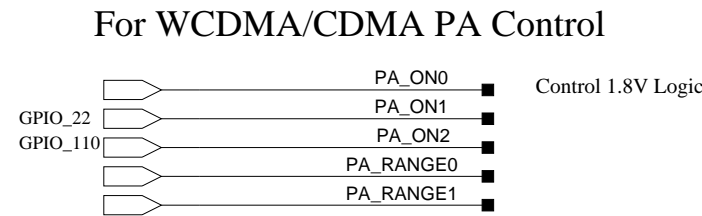
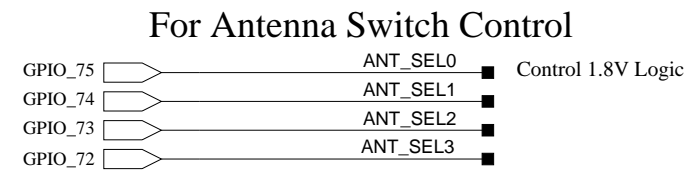

The type and specification of the components refer to the BOM

				NA	
				ECA NO	DATE
DESIGNED	ZHANGSAN XXXXX	HD1G520M		00001234	
REVIEWED	LISI XXXXX	VER	PART_NUMBER	SHEET 21 OF 37	
		A	03030001	HUAWAI TECH CO.,LTD.	

22. 19.2MHz VCTCXO/APT DCDC

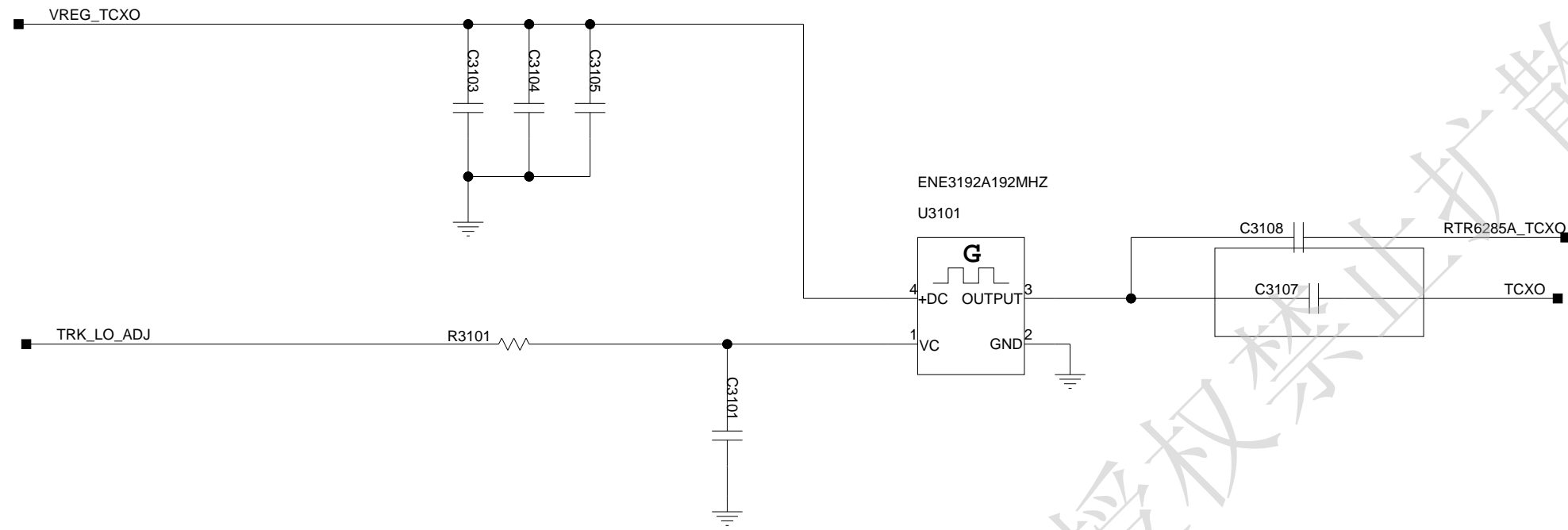

未经书面授权，
 华为机密，
 禁止扩散

The type and specification of the components refer to the BOM

				NA	
				ECA NO	DATE
DESIGNED	ZHANGSAN XXXXX	HD1G520M		00001234	
REVIEWED	LISI XXXXX	VER	PART_NUMBER	SHEET 22 OF 37	
		A	03030001	HUAWEI TECH CO.,LTD.	

23. Antenna Switchplexer

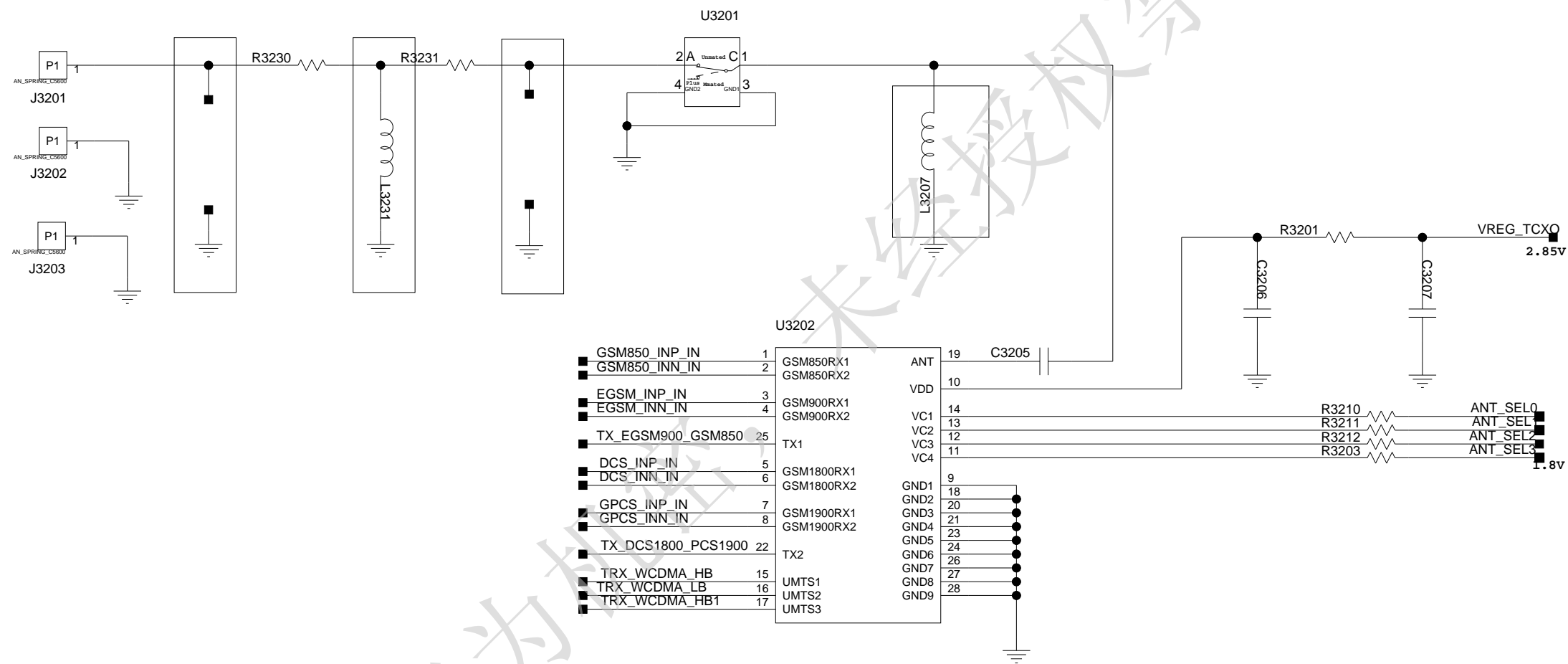

The type and specification of the components refer to the BOM

				NA	
				ECA NO	DATE
DESIGNED	ZHANGSAN XXXXX	HD1G520M		00001234	
REVIEWED	LISI XXXXX	VER	PART_NUMBER	SHEET 23 OF 37	
		A	03030001	HUAWEI TECH CO.,LTD.	

24. WCDMA IMT Power Amplifier

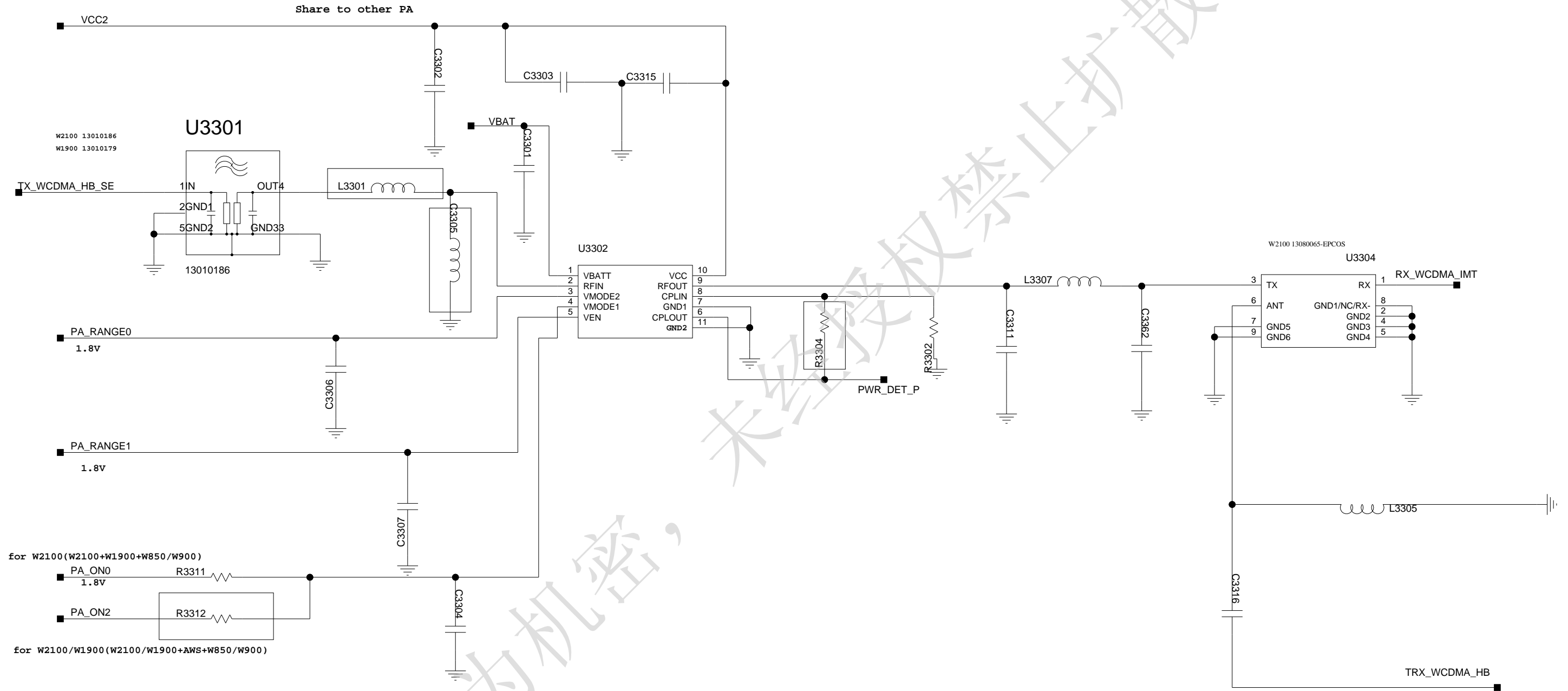

for W2100(W2100+W1900+W850/W900)
 PA_ON0 1.8V
 PA_ON2

for W2100/W1900(W2100/W1900+AWS+W850/W900)

WCDMA_PA_ON0/ON1	PA STATE
H	ON
L	OFF

PA_VMODE0	PA_VMODE1	MODE
L	L	High Power
L	H	Middle Power
H	H	Low Power

WCDMA_PA_ON0	W2100
WCDMA_PA_ON1	W1900
WCDMA_PA_ON2	W850/900

The type and specification of the components refer to the BOM

DESIGNED	ZHANGSAN XXXXX	HD1G520M	NA	
REVIEWED	LISI XXXXX		ECA NO	DATE
		VER	PART_NUMBER	SHEET 24 OF 37
		A	03030001	HUAWEI TECH CO.,LTD.

25. WCDMA CELL Power Amplifier

	W850		W900	
	Part number	CODE	Part number	CODE
U3401	ACPM_7311_TR1	47100231	ACPM_7371_TR1	47100187
U3402	B9425	13010174	SAFEB897MAL0F00R14	13010154
U3404	B7640	13080035	B7681	13080029

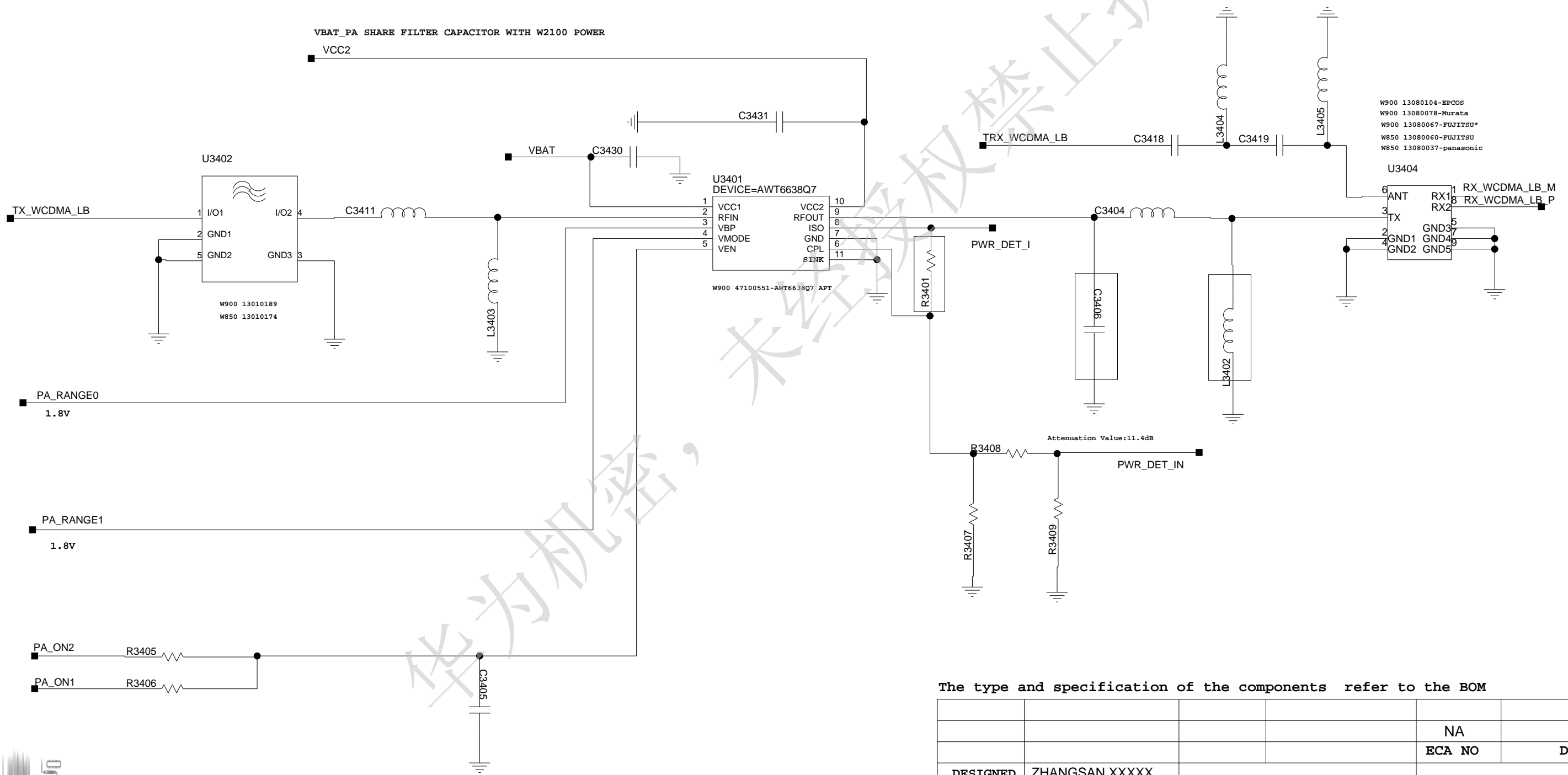

W900 13080104-EPCOS
W900 13080078-Murata
W900 13080067-FUJITSU*
W850 13080060-FUJITSU
W850 13080037-panasonic

The type and specification of the components refer to the BOM

				NA
			ECA NO	DATE
DESIGNED	ZHANGSAN XXXXX	HD1G520M		00001234
REVIEWED	LISI XXXXX	VER	PART_NUMBER	SHEET 25 OF 37
		A	03030001	HUAWEI TECH CO.,LTD.

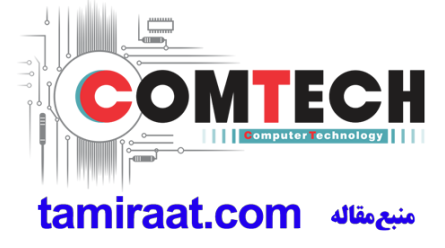

26. GSM Quad_band_PA

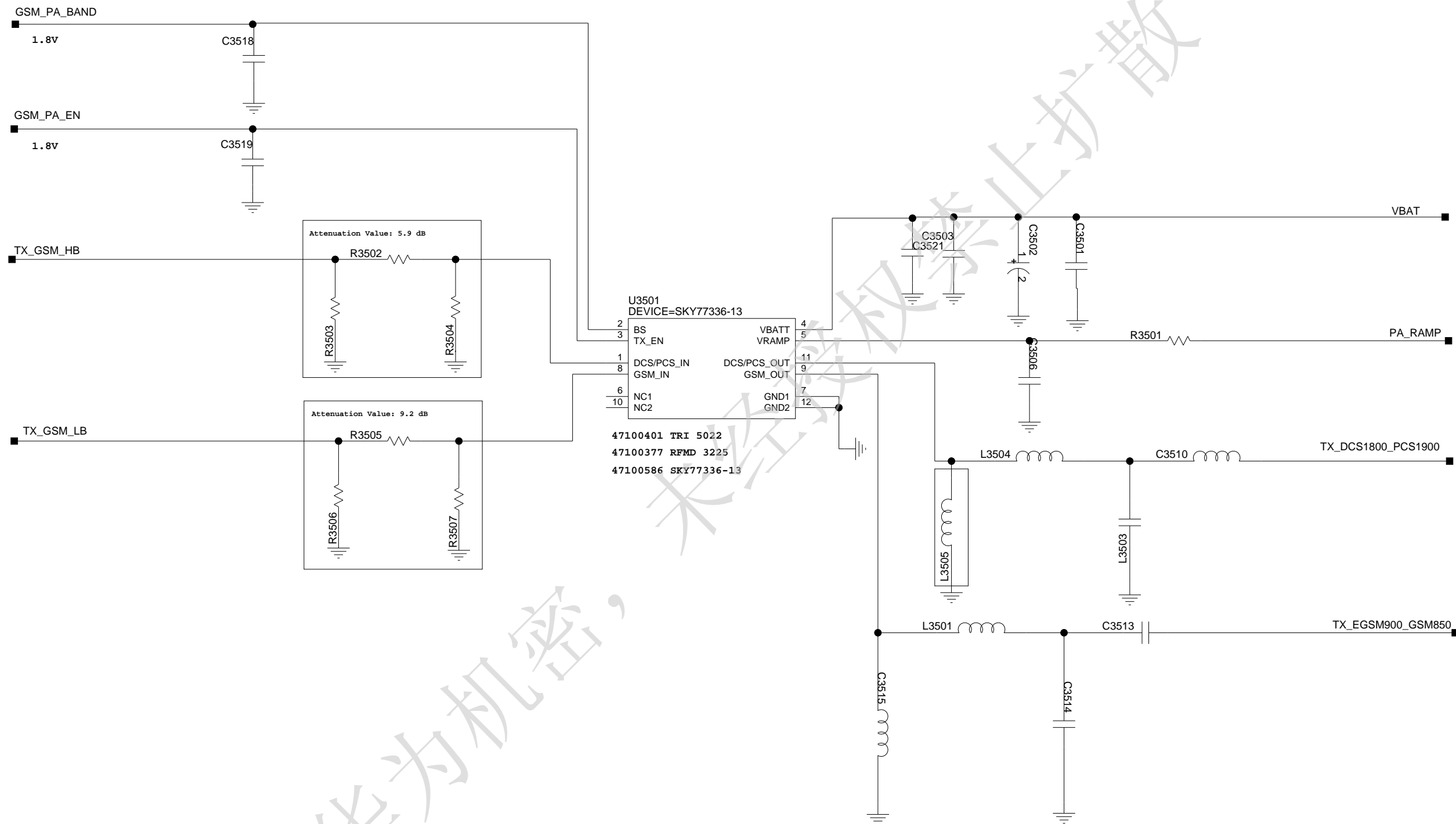

The type and specification of the components refer to the BOM

				NA	
				ECA NO	DATE
DESIGNED	ZHANGSAN XXXXX	HD1G520M		00001234	
REVIEWED	LISI XXXXX	VER	PART_NUMBER	SHEET 26 OF 37	
		A	03030001	HUAWEI TECH CO.,LTD.	

27. RX MATCHING CIRCUIT

GSM850 RX MATCHING

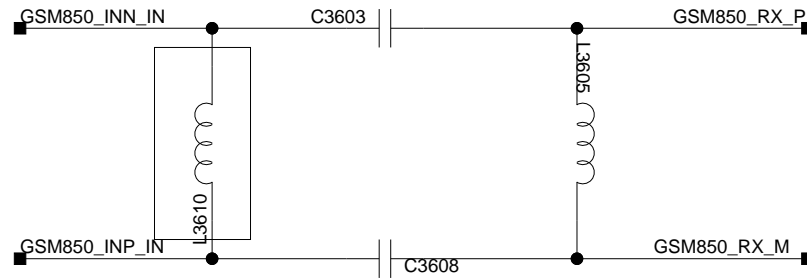

GSM900 RX MATCHING



GSM1800 RX MATCHING

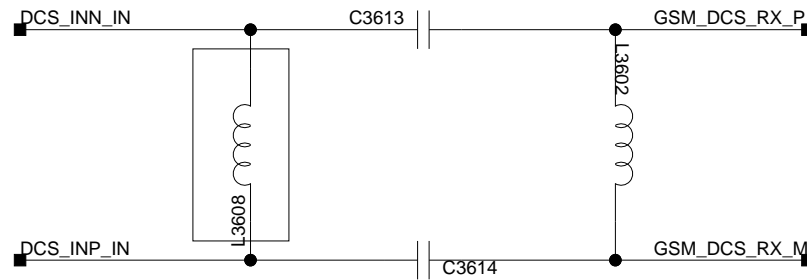

PCS1900 RX MATCHING

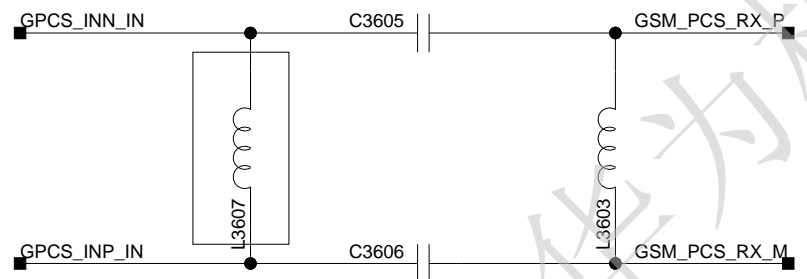

W2100 PRIMARY RX MATCHING

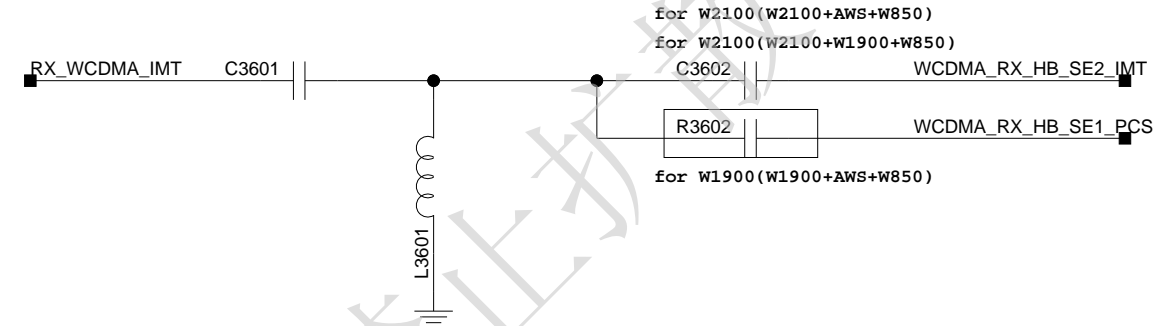

W850/900 PRIMARY RX MATCHING

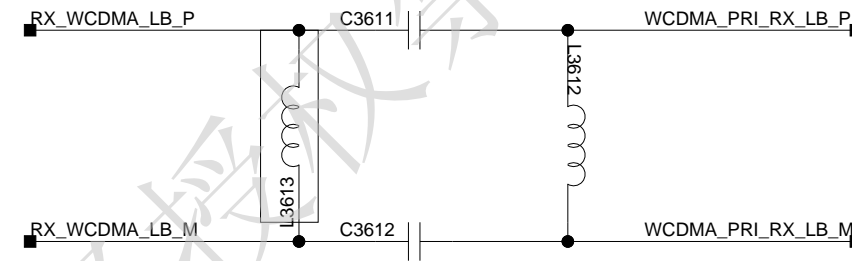

PCS PRIMARY RX MATCHING

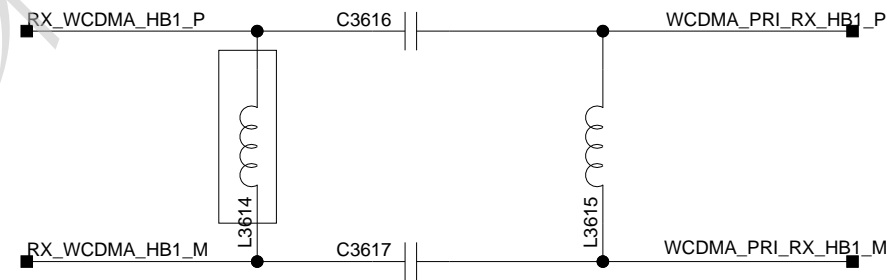

The type and specification of the components refer to the BOM

				NA	
				ECA NO	DATE
DESIGNED	ZHANGSAN XXXXX	HD1G520M		00001234	
REVIEWED	LISI XXXXX	VER	PART_NUMBER	SHEET 27 OF 37	
		A	03030001	HUAWAI TECH CO.,LTD.	

28. UMTS IMT RX INTERSTAGE CHAIN

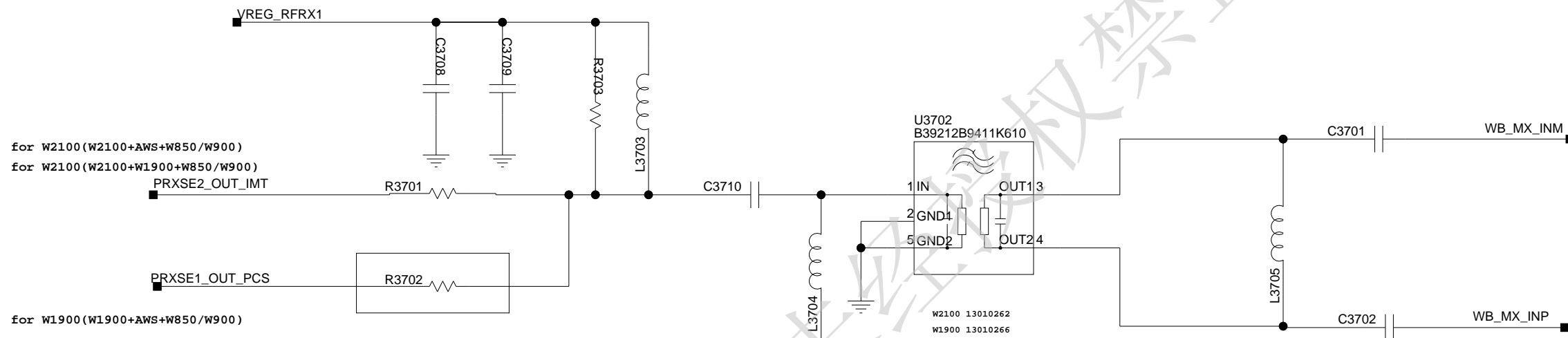

华为机密，未经授权禁止扩散

The type and specification of the components refer to the BOM

				NA	
				ECA NO	DATE
DESIGNED	ZHANGSAN XXXXX	HD1G520M		00001234	
REVIEWED	LISI XXXXX	VER	PART_NUMBER	SHEET 28 OF 37	
		A	03030001	HUAWEI TECH CO.,LTD.	

29. RTR6285A CIRCUIT

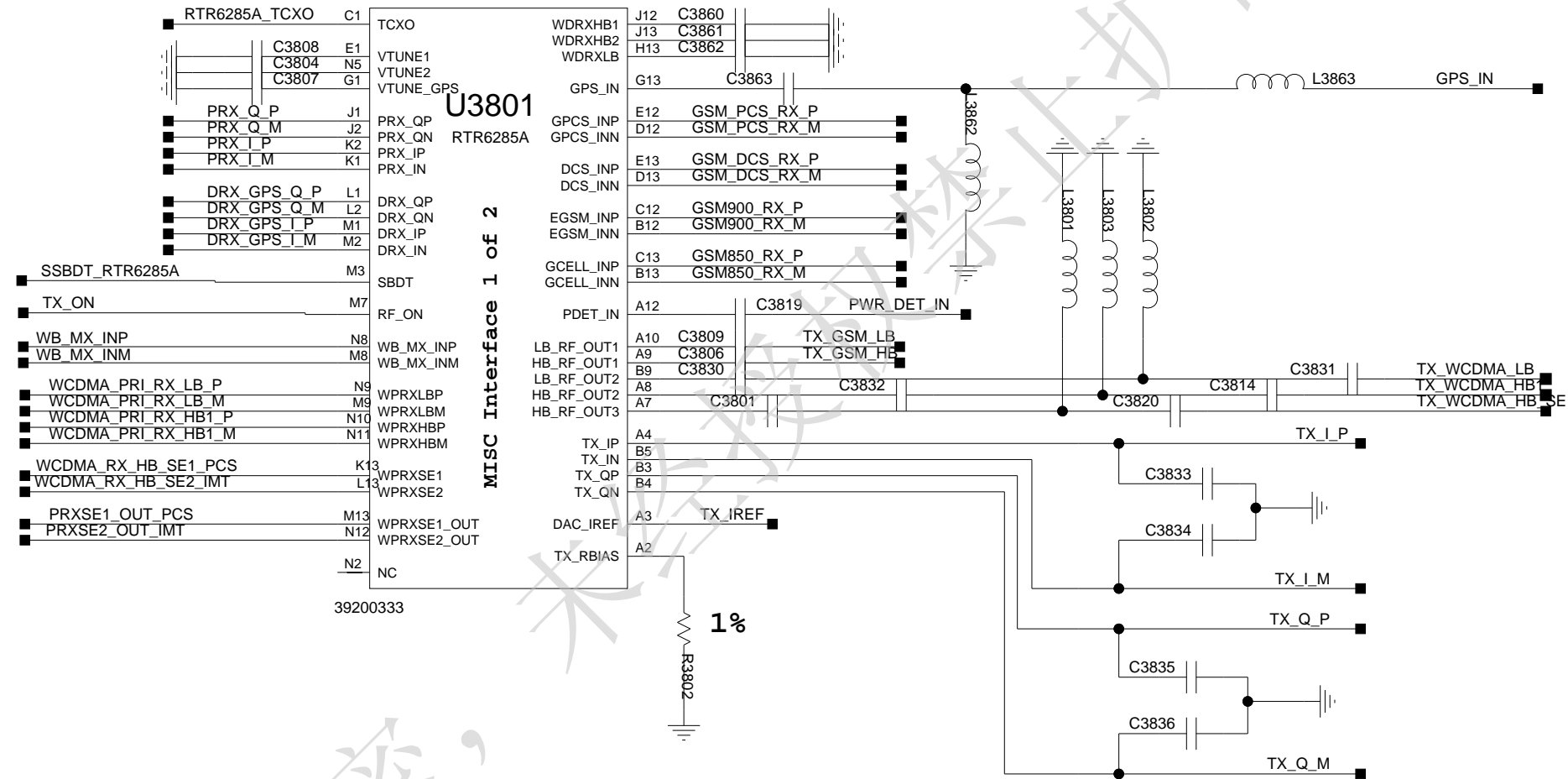

The type and specification of the components refer to the BOM

				NA
			ECA NO	DATE
DESIGNED	ZHANGSAN XXXXX	HD1G520M		00001234
REVIEWED	LISI XXXXX	VER	PART_NUMBER	SHEET 29 OF 37
		A	03030001	HUAWEI TECH CO.,LTD.

30. RTR6285A POWER DISTRIBUTION

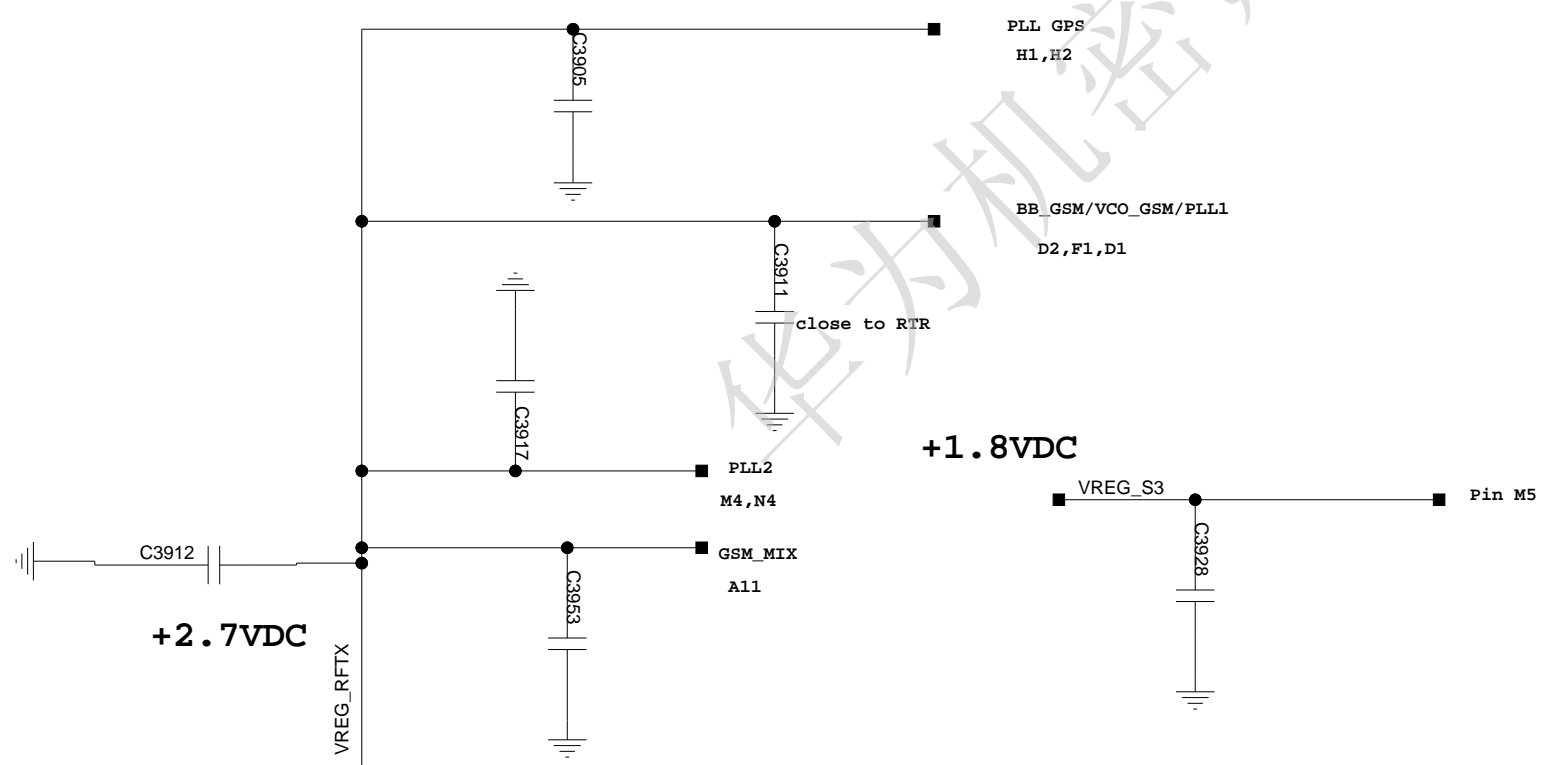
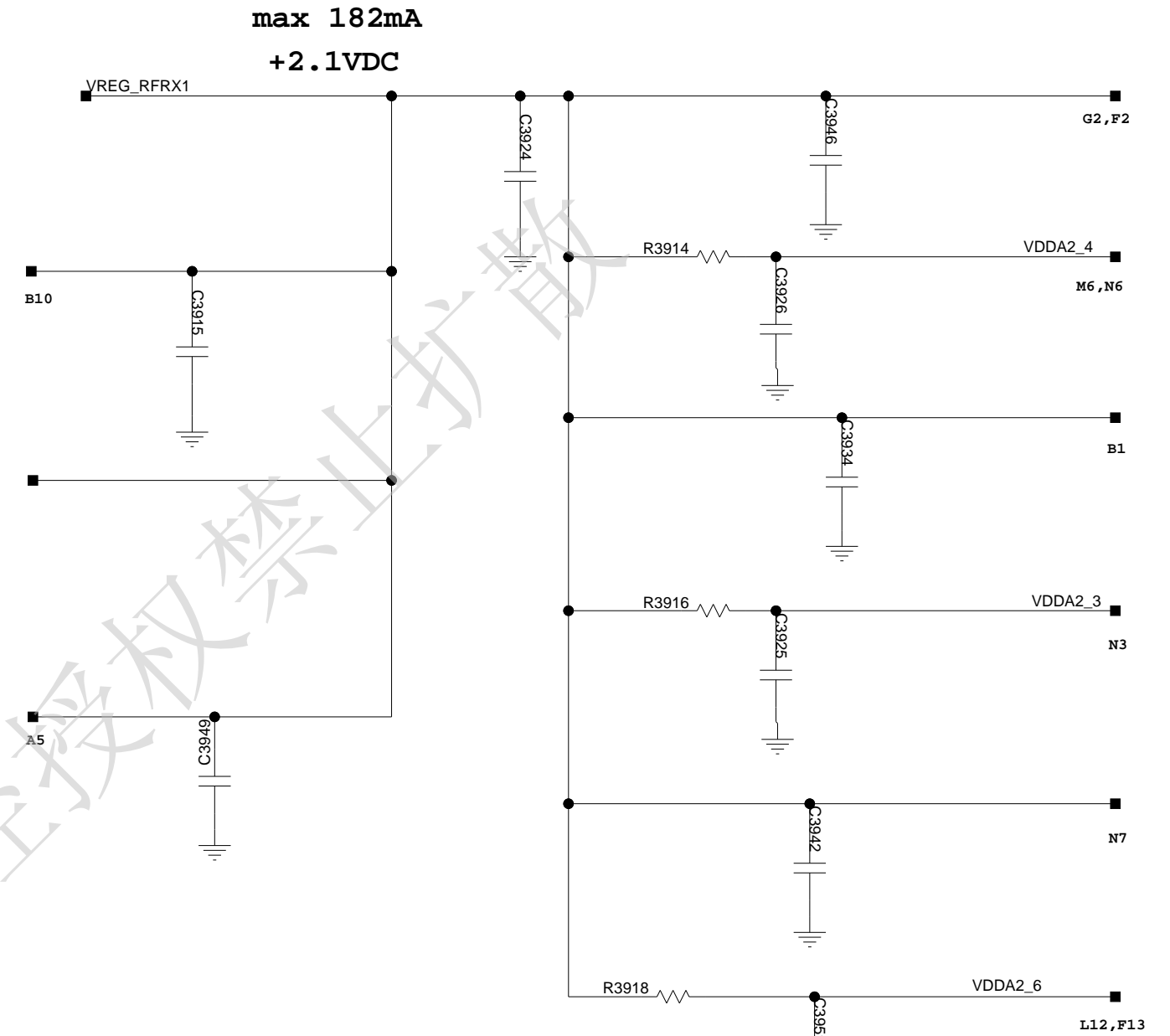
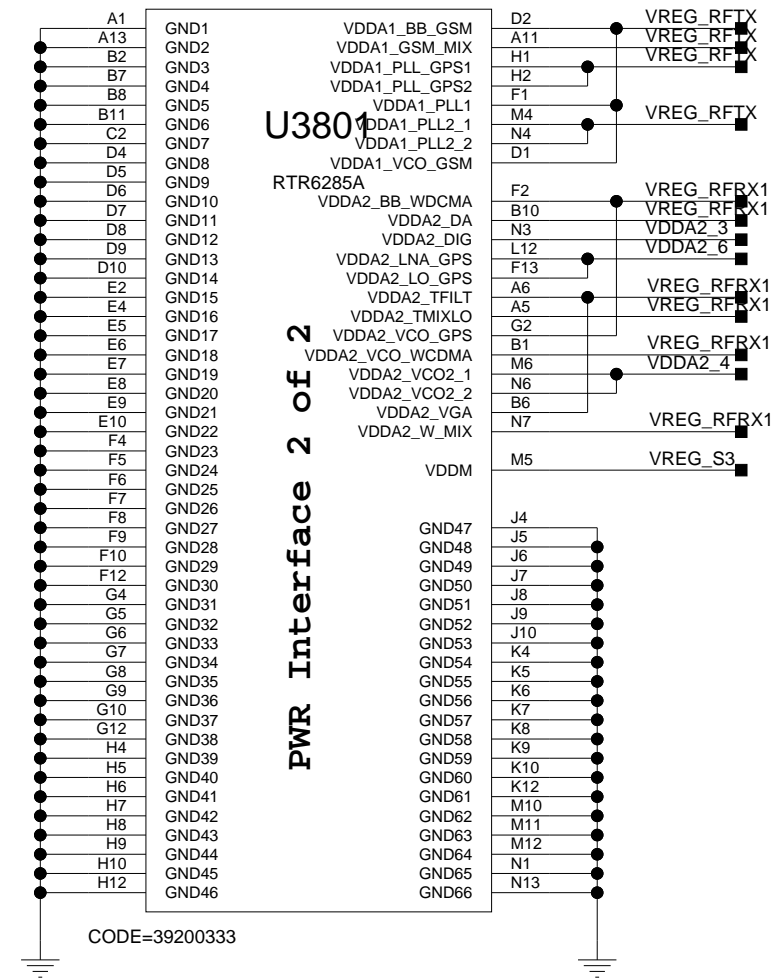

The type and specification of the components refer to the BOM

DESIGNED	ZHANGSAN XXXXX	HD1G520M	NA
REVIEWED	LISI XXXXX		ECA NO
			DATE
			00001234
		VER	PART_NUMBER
		A	03030001
			SHEET 30 OF 37
			HUAWEI TECH CO.,LTD.

31.GPS

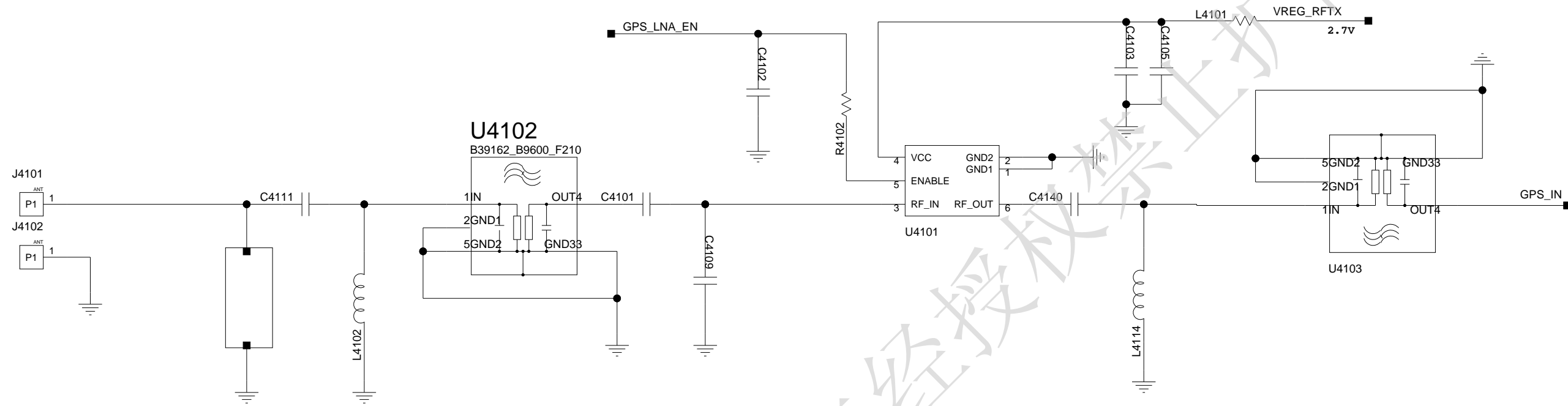

未经授权的复制，
华为机密，

The type and specification of the components refer to the BOM

				NA	
				ECA NO	DATE
DESIGNED	ZHANGSAN XXXXX	HD1G520M		00001234	
REVIEWED	LISI XXXXX	VER	PART_NUMBER	SHEET 31 OF 37	
		A	03030001	HUAWEI TECH CO.,LTD.	

32.WCDMA PCS Power Amplifier

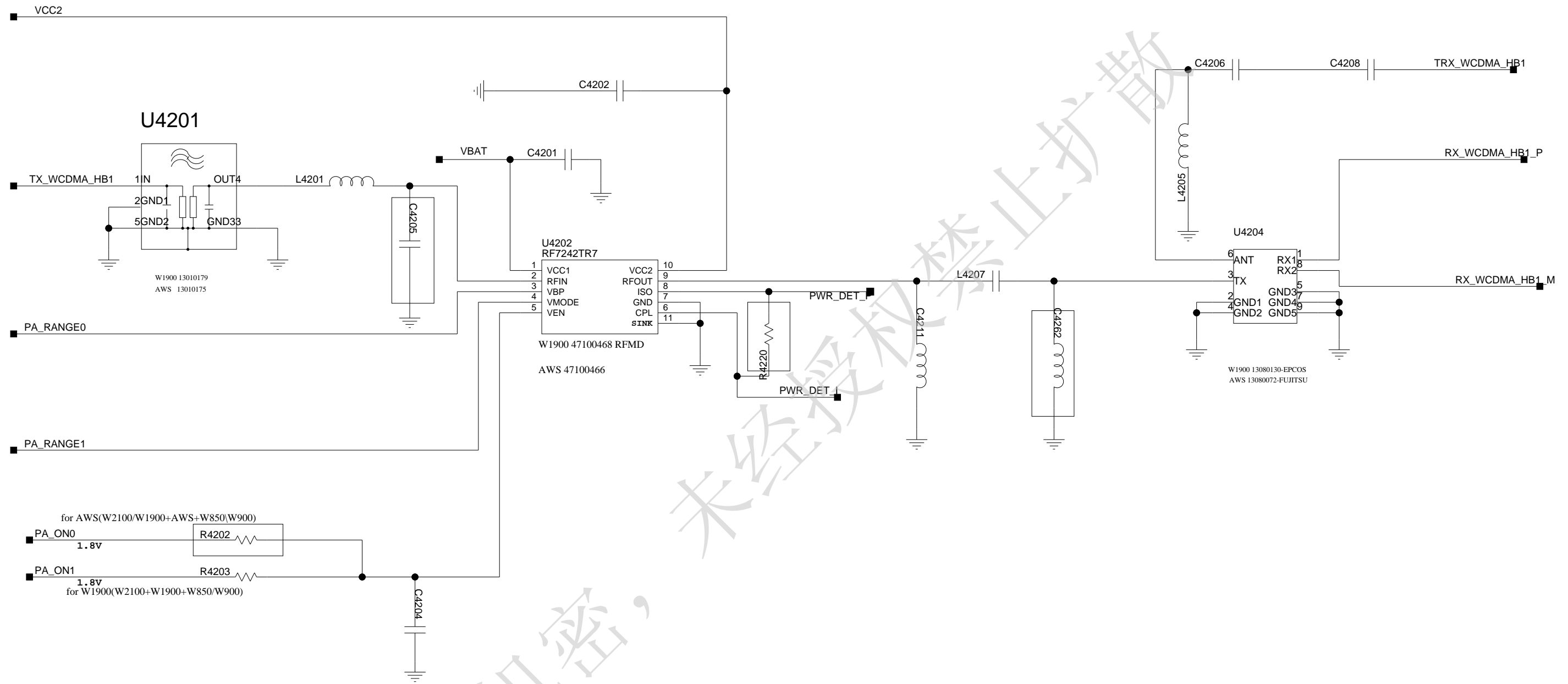

The type and specification of the components refer to the BOM

				NA	
				ECA NO	DATE
DESIGNED	ZHANGSAN XXXXX	HD1G520M		00001234	
REVIEWED	LISI XXXXX	VER	PART_NUMBER	SHEET 32 OF 37	
		A	03030001	HUAWEI TECH CO.,LTD.	

华为机密，未经授权禁止扩散

The type and specification of the components refer to the BOM

				NA	
				ECA NO	DATE
DESIGNED	ZHANGSAN XXXXX	HD1G520M		00001234	
REVIEWED	LISI XXXXX				
		VER	PART_NUMBER	SHEET 33 OF 37	
		A	03030001	HUAWEI TECH CO.,LTD.	



34. NFC

IF0=IF1=GND, I2C ADDRESS is 0x50(0x28+R/W)

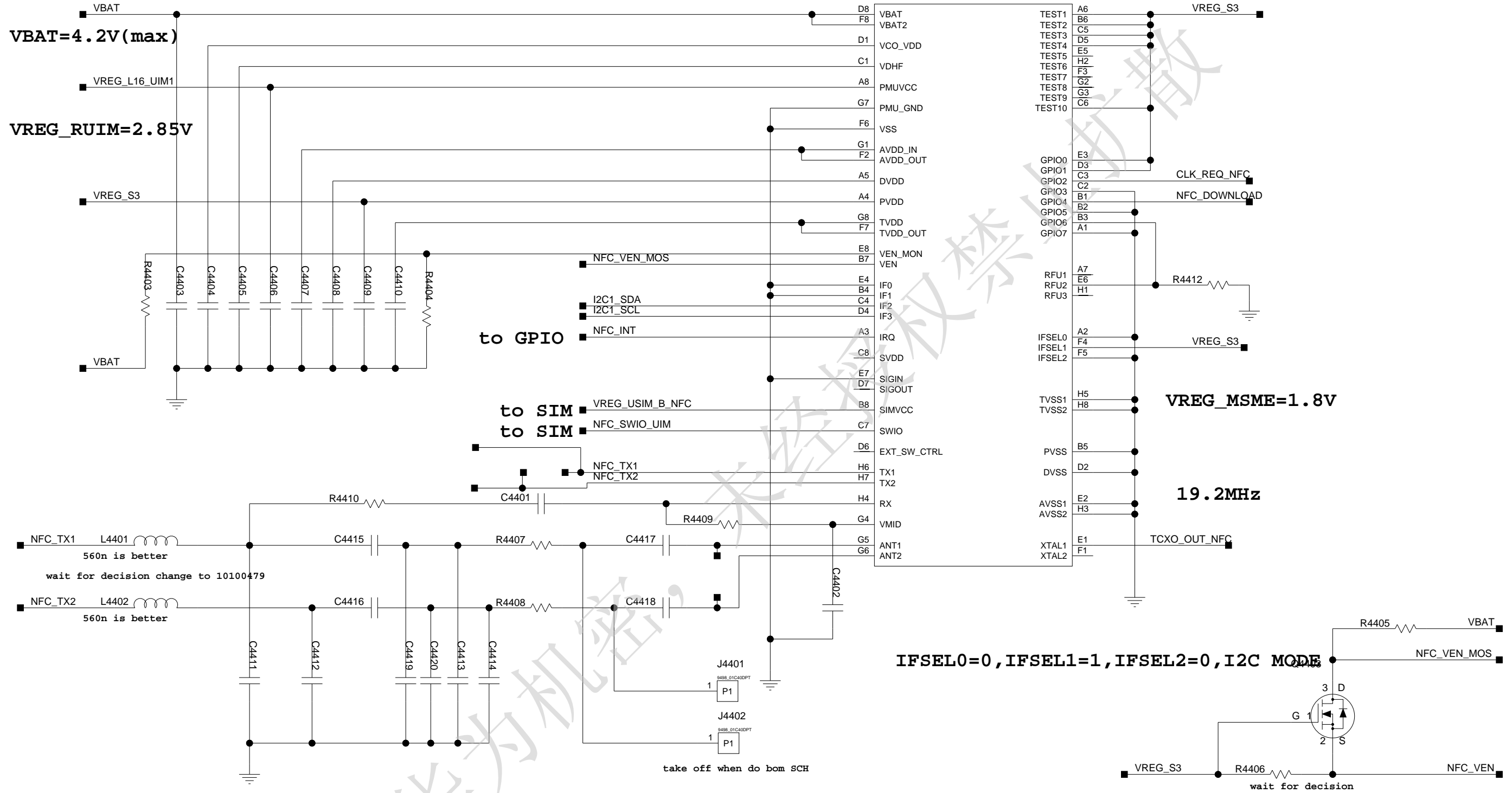

IFSEL0=0, IFSEL1=1, IFSEL2=0, I2C MODE

The type and specification of the components refer to the BOM

				NA	@DATETIME=1-21-2013_20:24
				ECA NO	DATE
DESIGNED	ZHANGSAN XXXXX	HD1G520M		00001234	
REVIEWED	LISI XXXXX	VER	PART_NUMBER	SHEET 34 OF 37	
		A	03030001	HUAWEI TECH CO.,LTD.	



35.BT FM WCN2243

change@10.15
Delete R6005 R6006 R6007

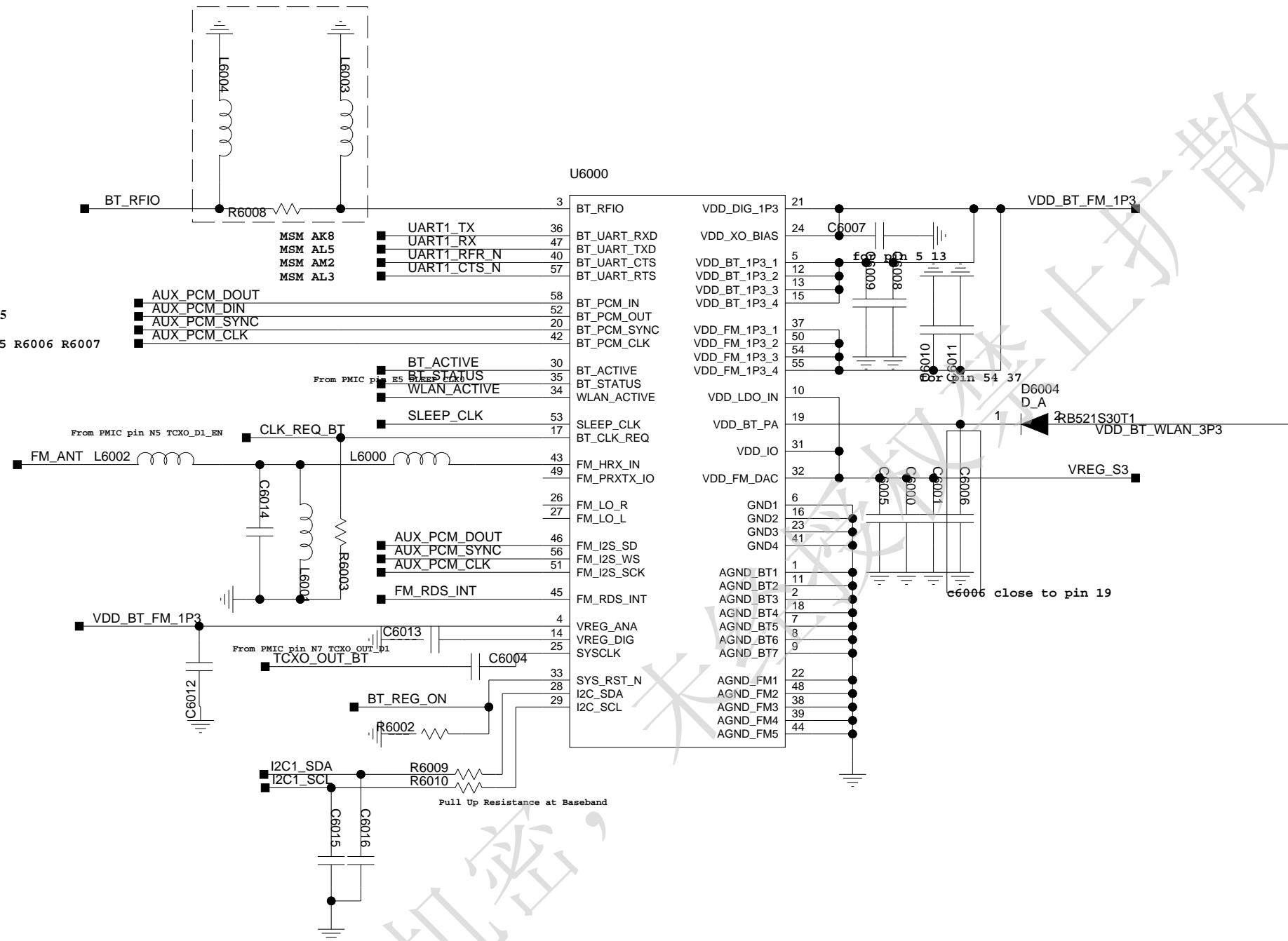

The type and specification of the components refer to the BOM

				NA	
				ECA NO	DATE
DESIGNED	ZHANGSAN XXXXX	HD1G520M		00001234	
REVIEWED	LISI XXXXX	VER	PART_NUMBER	SHEET 35 OF 37	
		A	03030001	HUAWEI TECH CO.,LTD.	

36.AR6005 BB

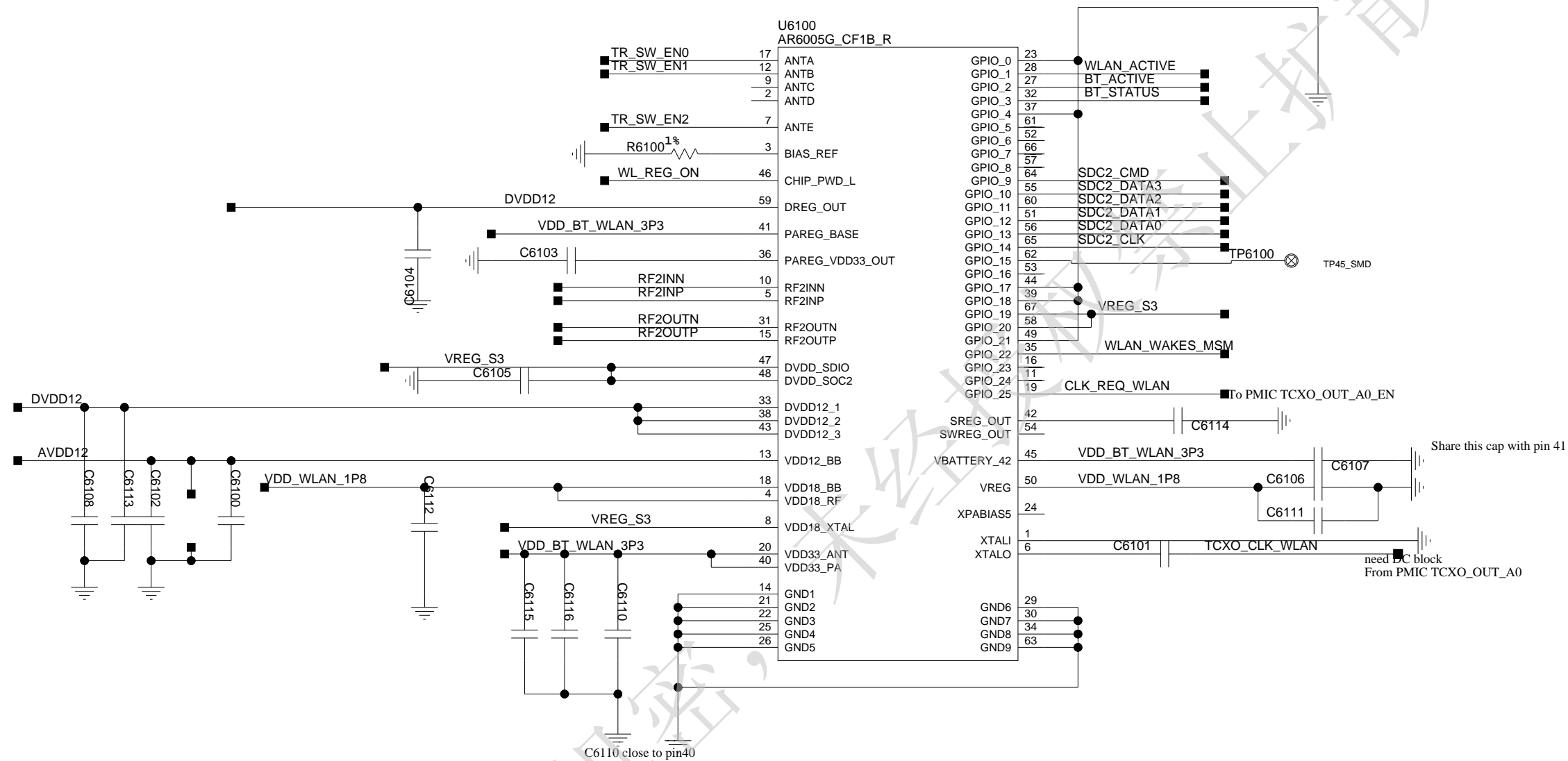

The type and specification of the components refer to the BOM

				NA	
				ECA NO	DATE
DESIGNED	ZHANGSAN XXXXX	HD1G520M		00001234	
REVIEWED	LISI XXXXX	VER	PART_NUMBER	SHEET 36 OF 37	
		A	03030001	HUAWAI TECH CO.,LTD.	

37.AR6005 RF

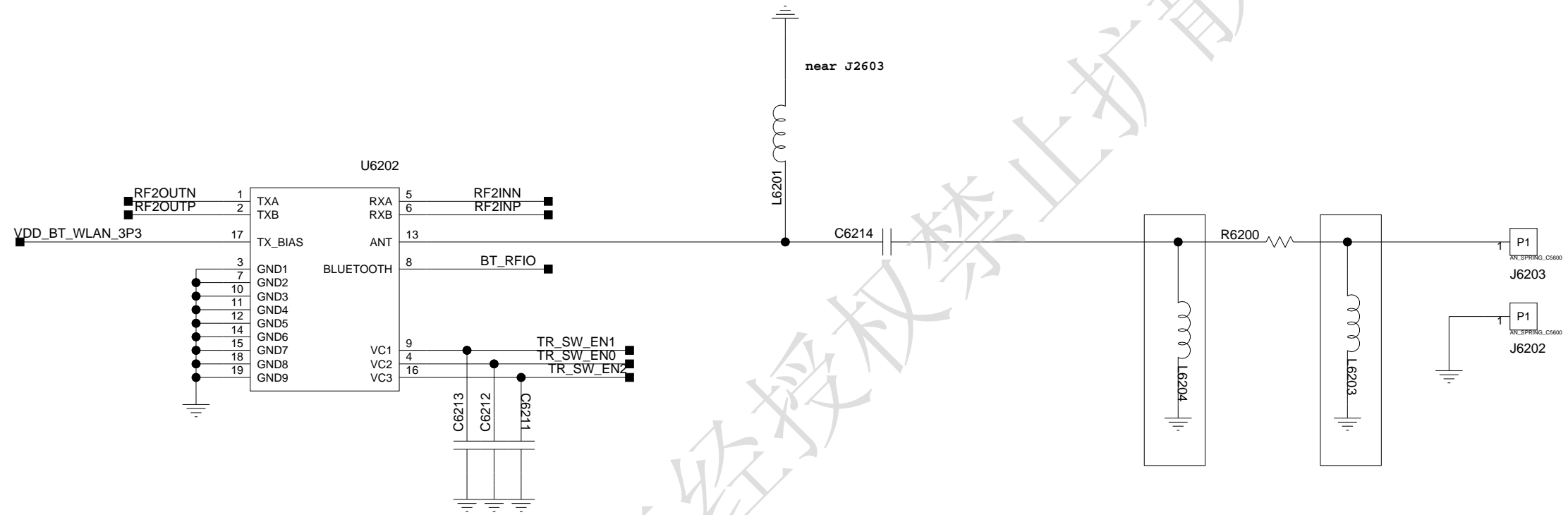

未经授权 禁止扩散
 华为机密

The type and specification of the components refer to the BOM

				NA	
				ECA NO	DATE
DESIGNED	ZHANGSAN XXXXX	HD1G520M		00001234	
REVIEWED	LISI XXXXX	VER	PART_NUMBER	SHEET 37 OF 37	
		A	03030001	HUAWEI TECH CO.,LTD.	