

Ant Con&Coupler & Switchplexer

Title		
A1		
Size	Document Number	Rev
A3	<Doc>	P0
Date:	Wednesday, December 09, 2015	Sheet 1 of 37

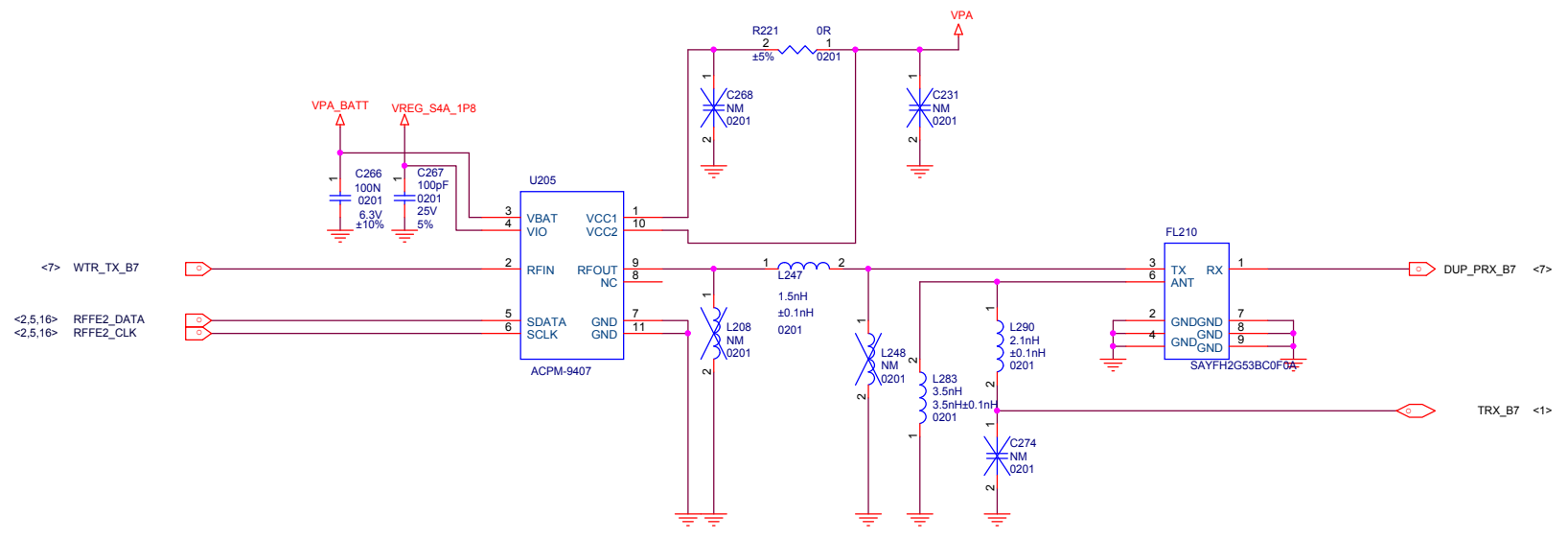

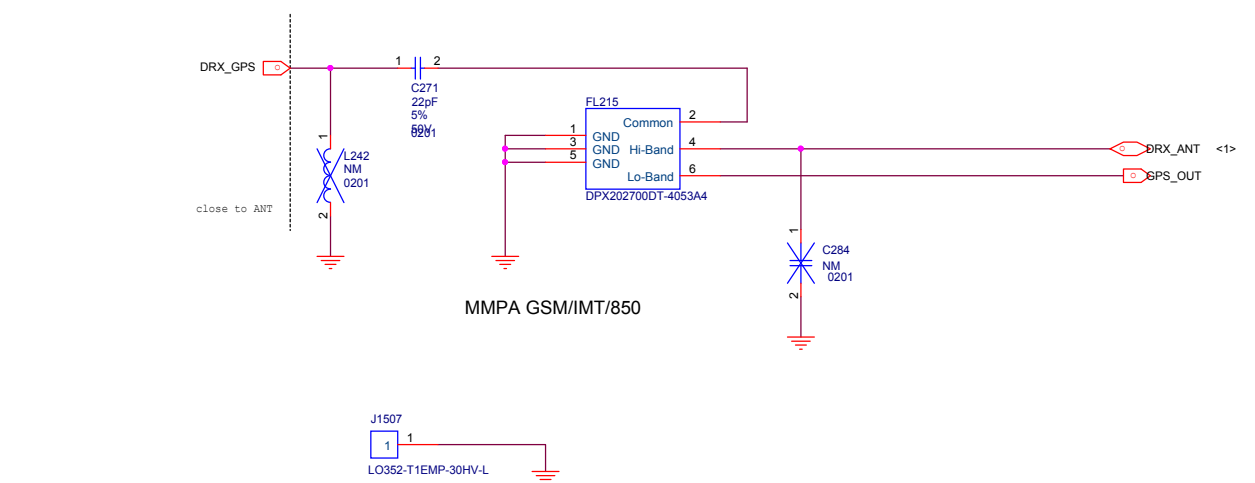
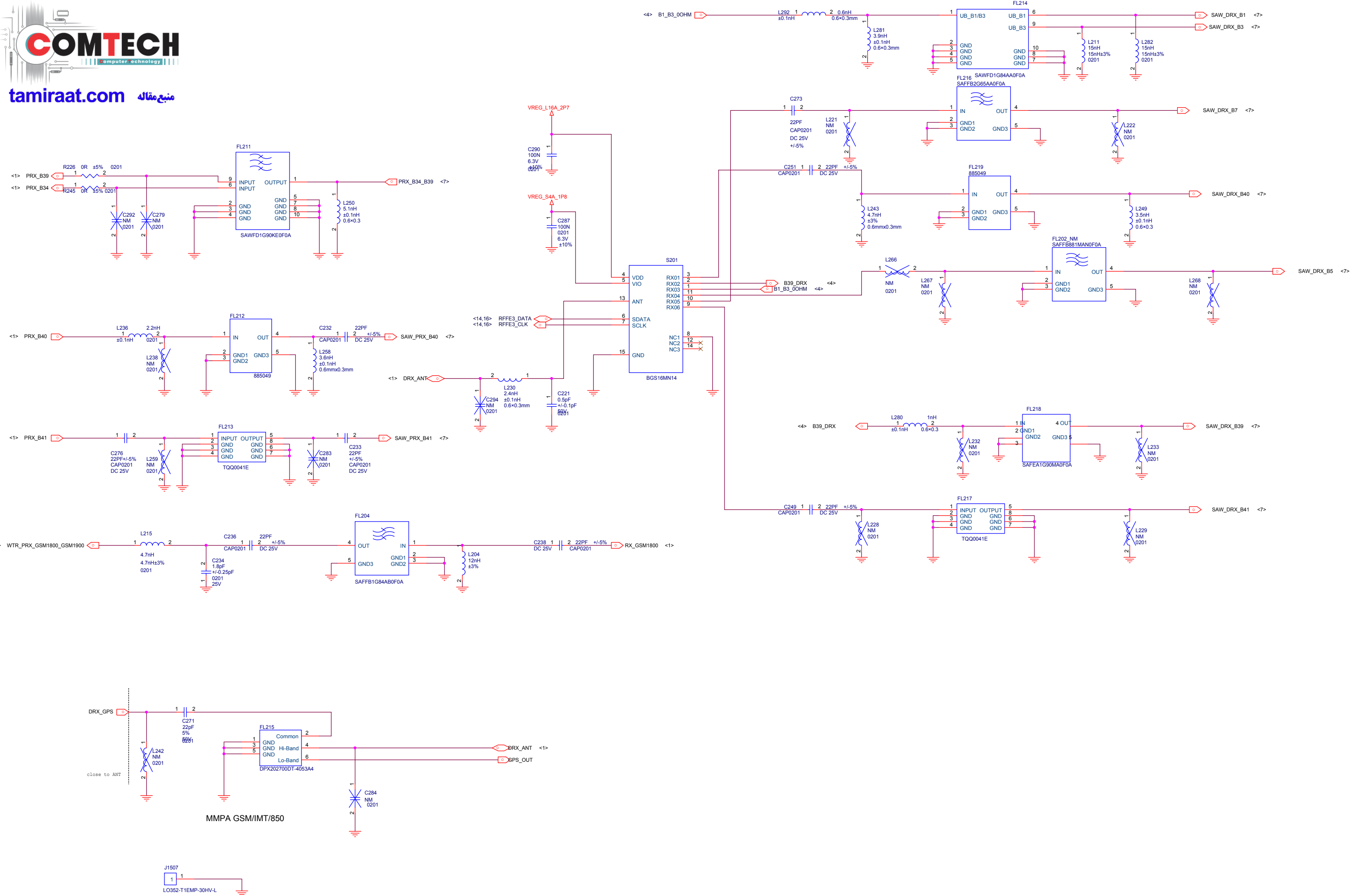

TX FILTERS&GSM1800&DRX_B

Title	A1	Rev	P0
Size	Document Number	<Doc>	
A2	<Doc>		
Date:	Wednesday, December 09, 2015	Sheet	4 of 37

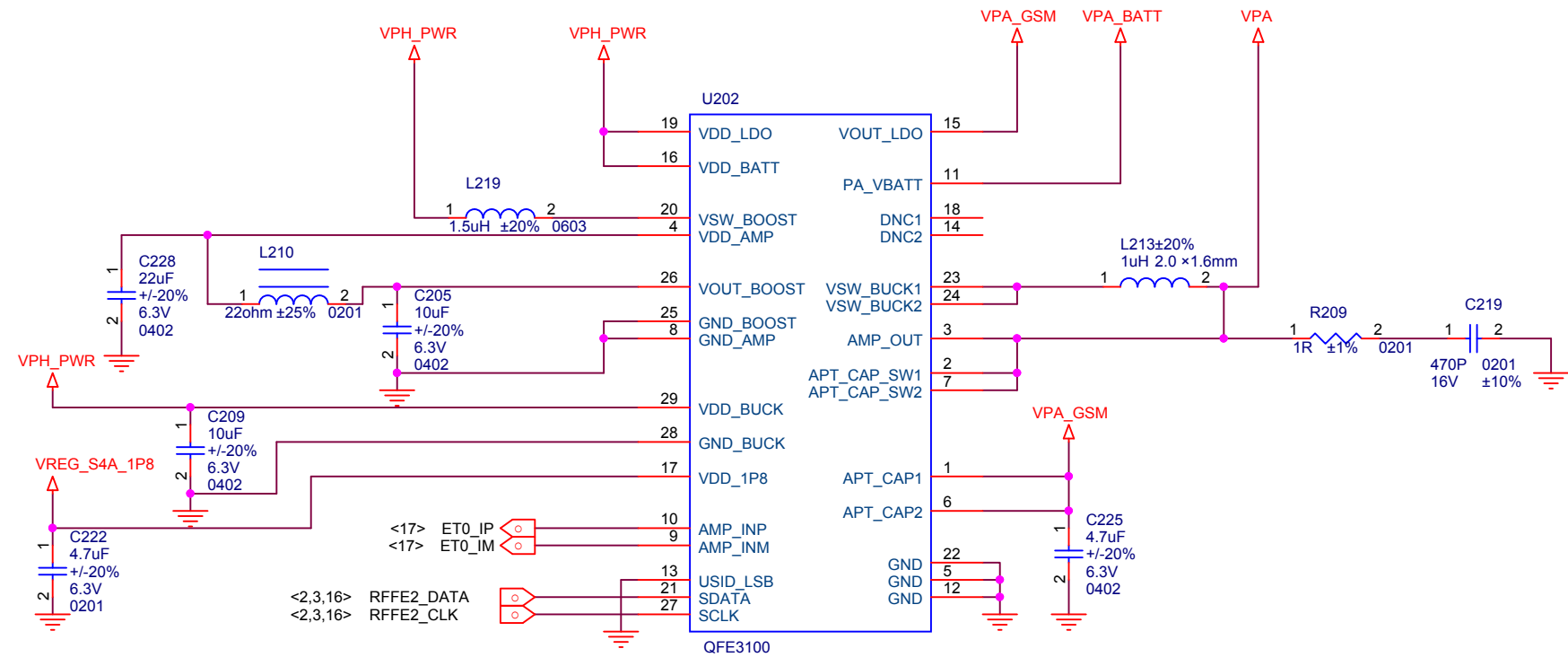

QFE3100

Title		
A1		
Size	Document Number	Rev
A3	<Doc>	P0
Date:	Wednesday, December 09, 2015	Sheet 5 of 37

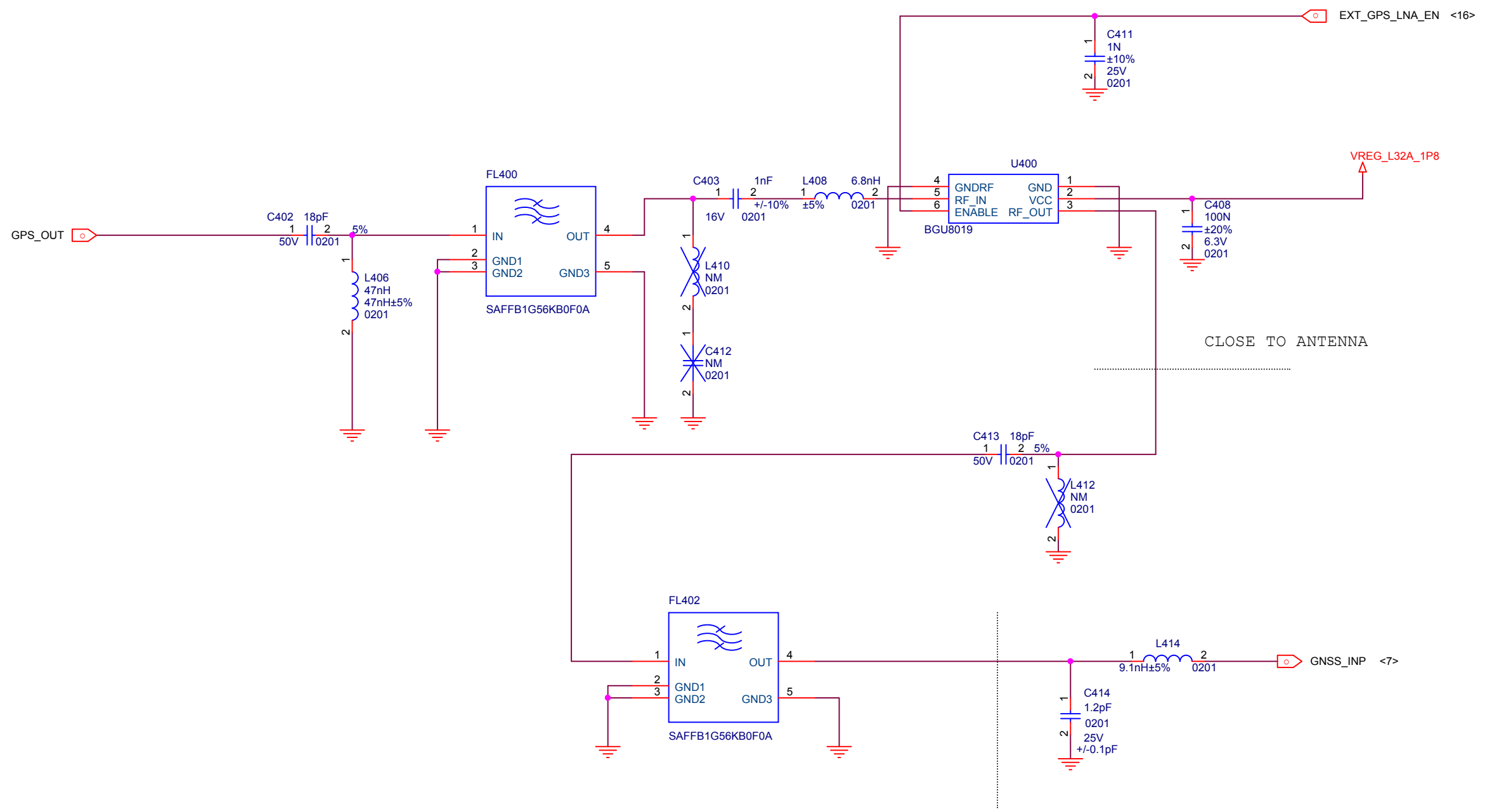

GPS		
Title A1		
Size A3	Document Number <Doc>	Rev P0
Date:	Wednesday, December 09, 2015	Sheet 6 of 37

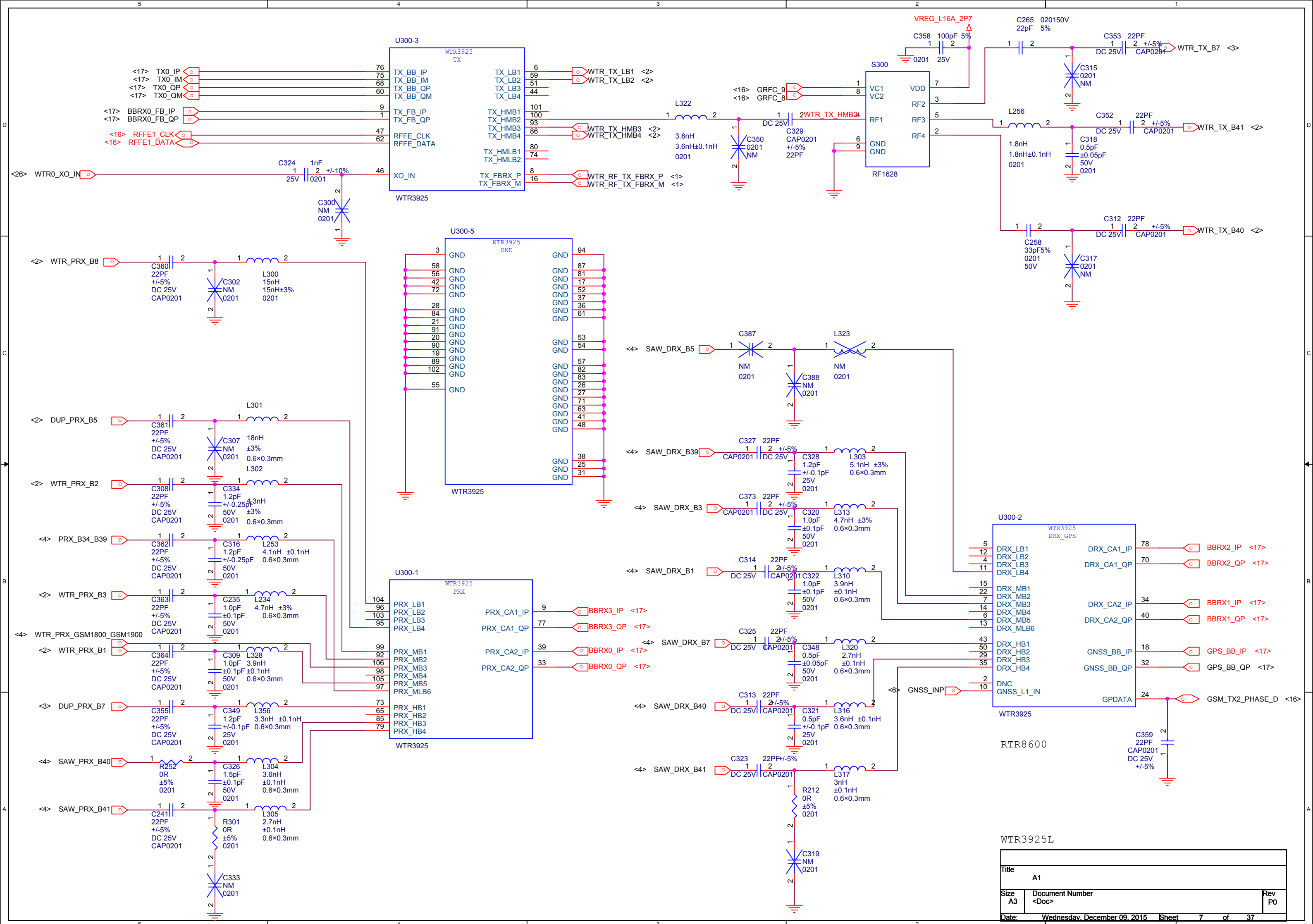

Title		
A1		
Size	Document Number	Rev
A3	<Doc>	P0
Date:	Wednesday, December 09, 2015	Sheet 7 of 37

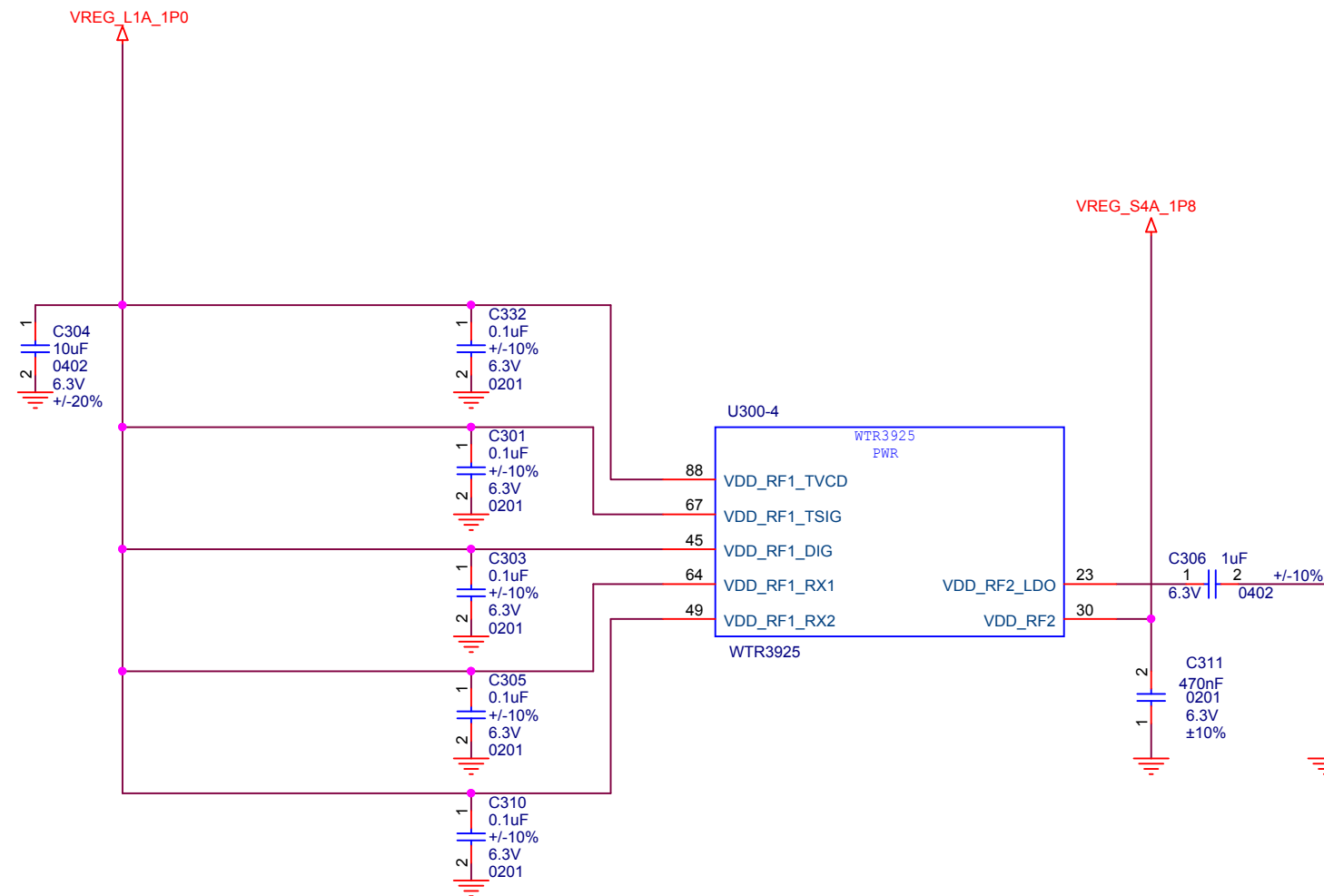

WTR3925L BYPASS

Title		
A1		
Size	Document Number	Rev
A3	<Doc>	P0
Date:	Wednesday, December 09, 2015	Sheet 8 of 37

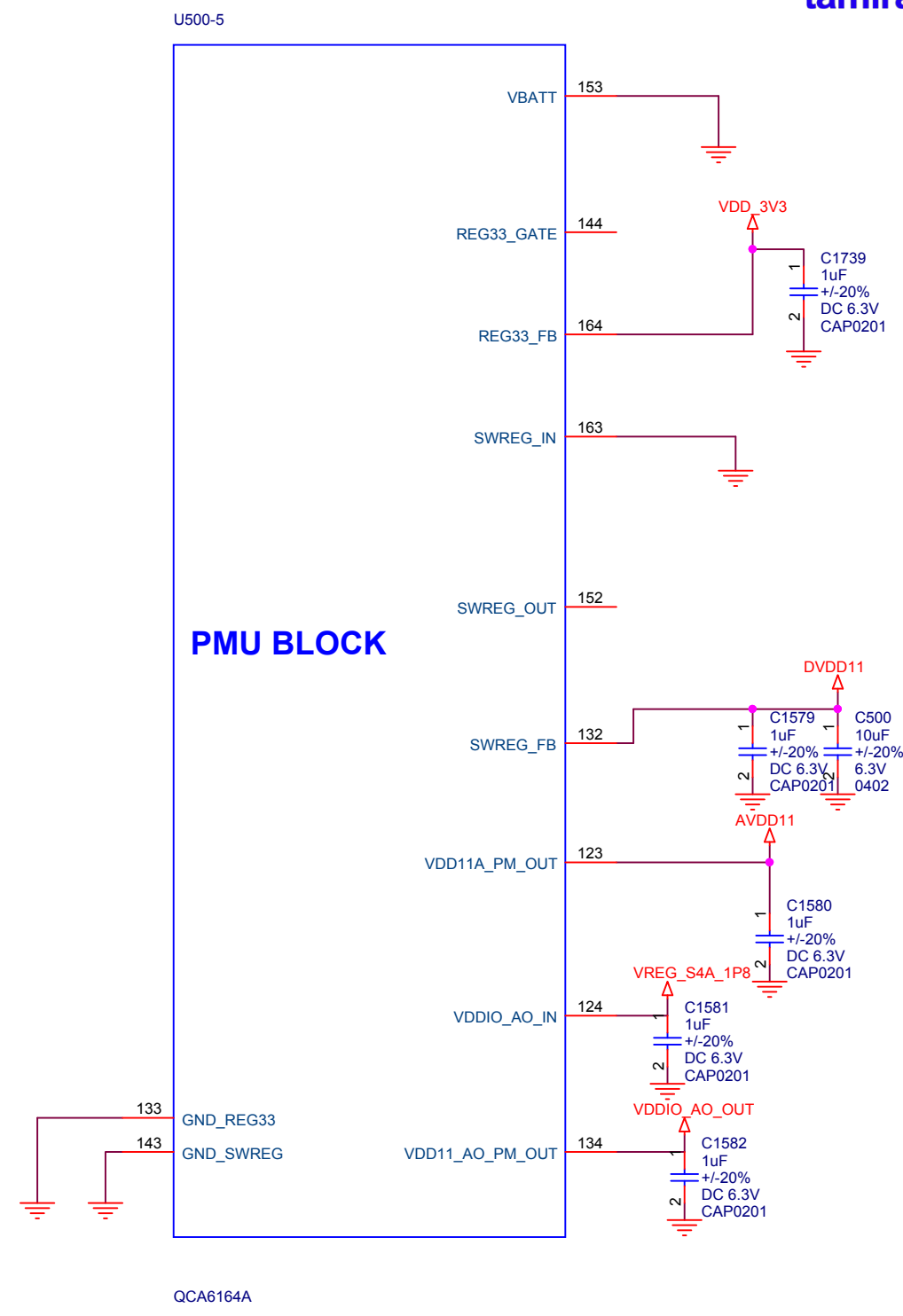
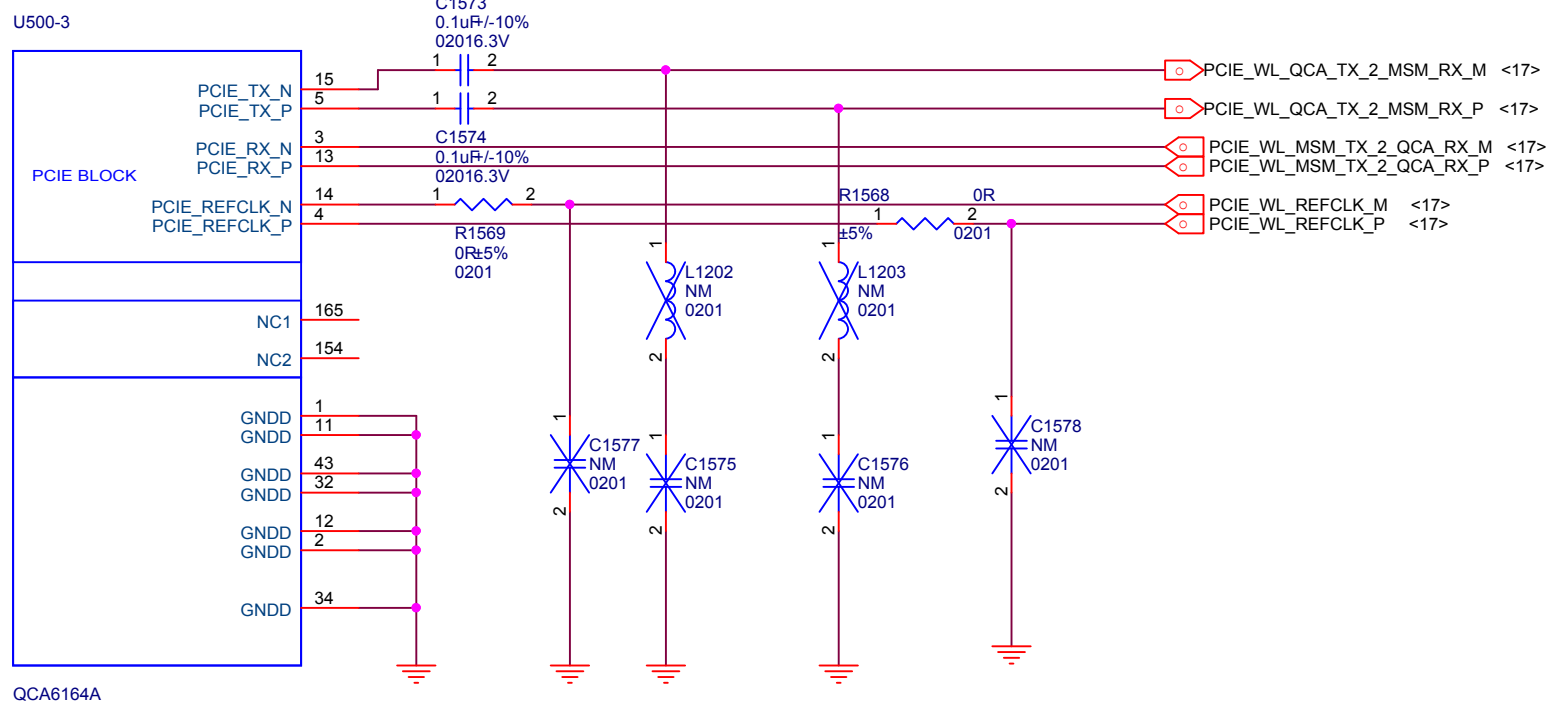
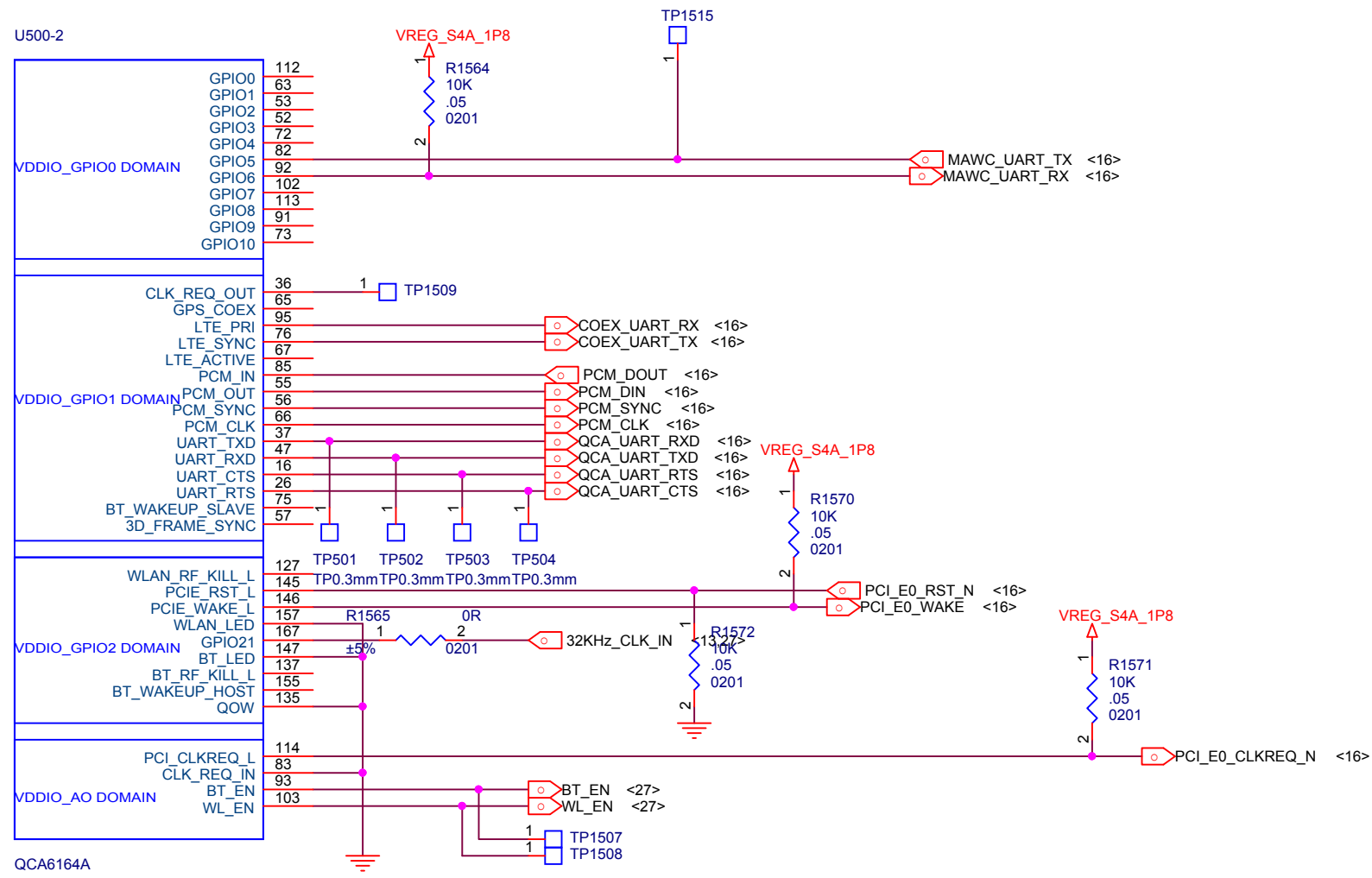

WIFI INTERFACE

Title		
A1		
Size	Document Number	Rev
A3	<Doc>	P0
Date:	Wednesday, December 09, 2015	Sheet 9 of 37

U500-4

POWER

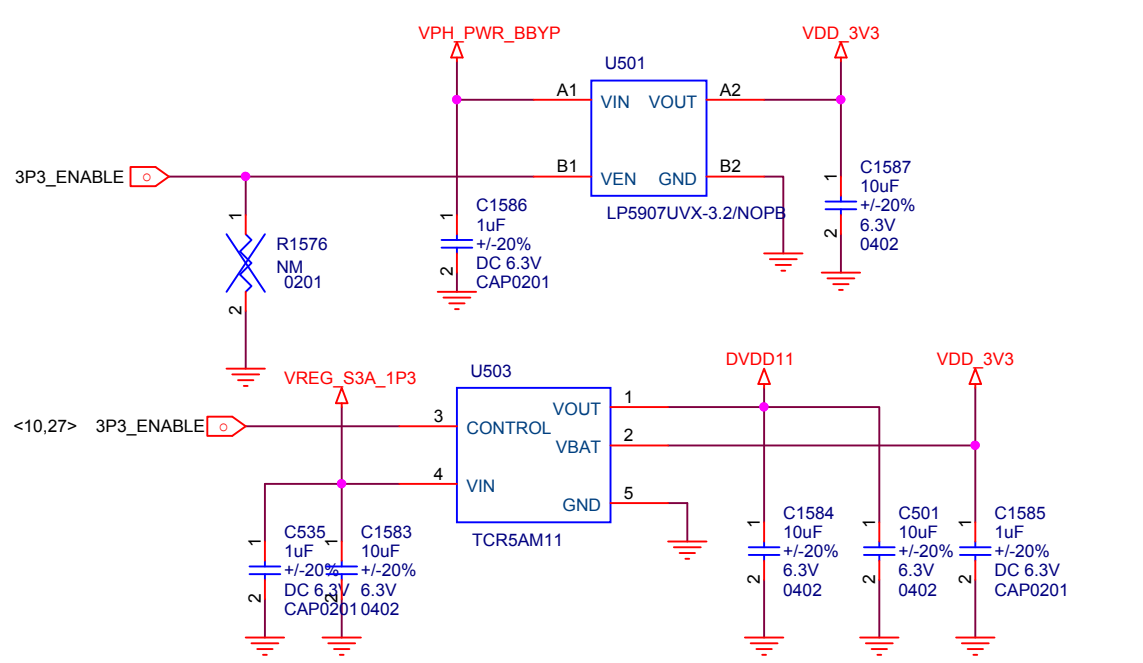
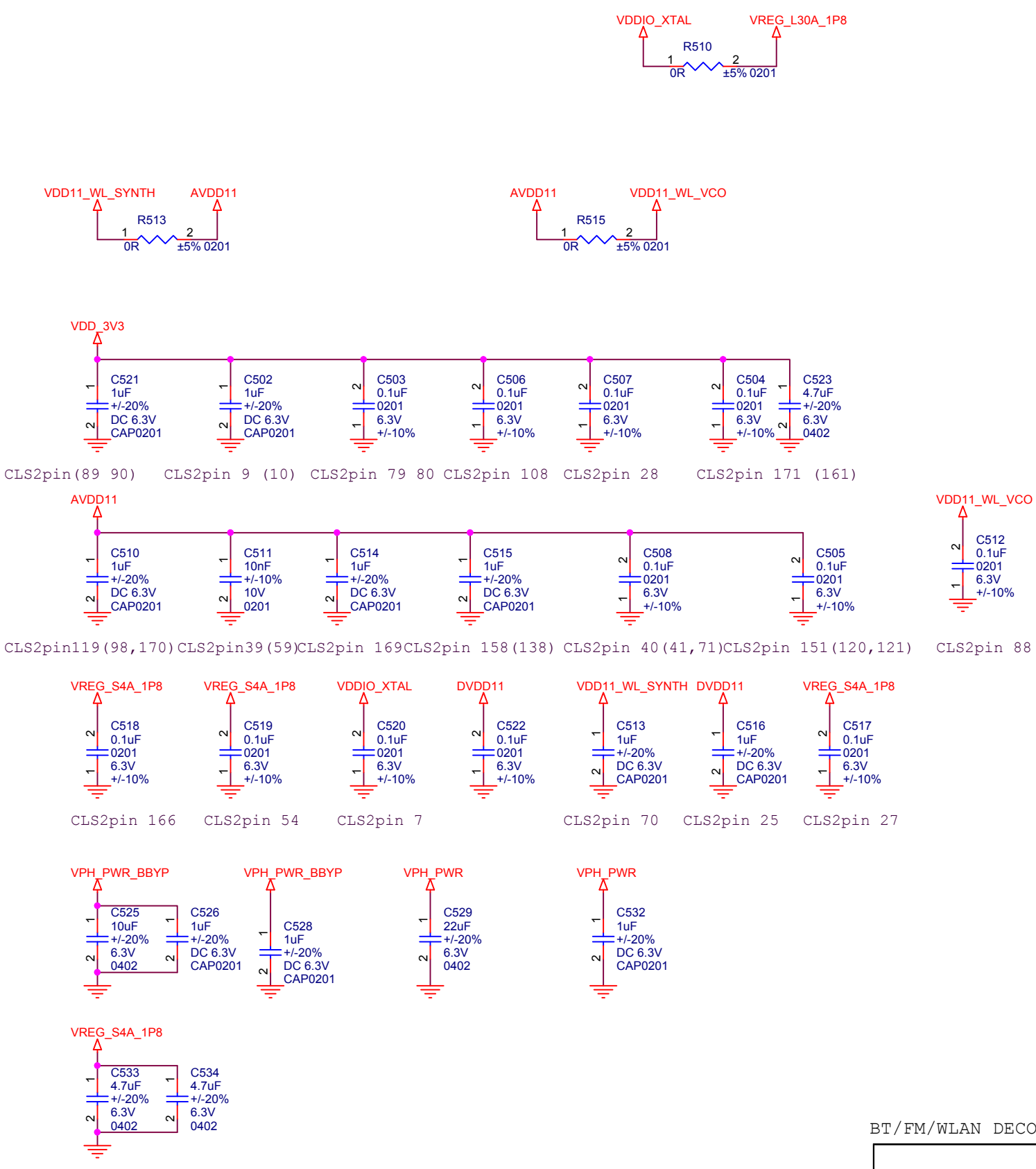
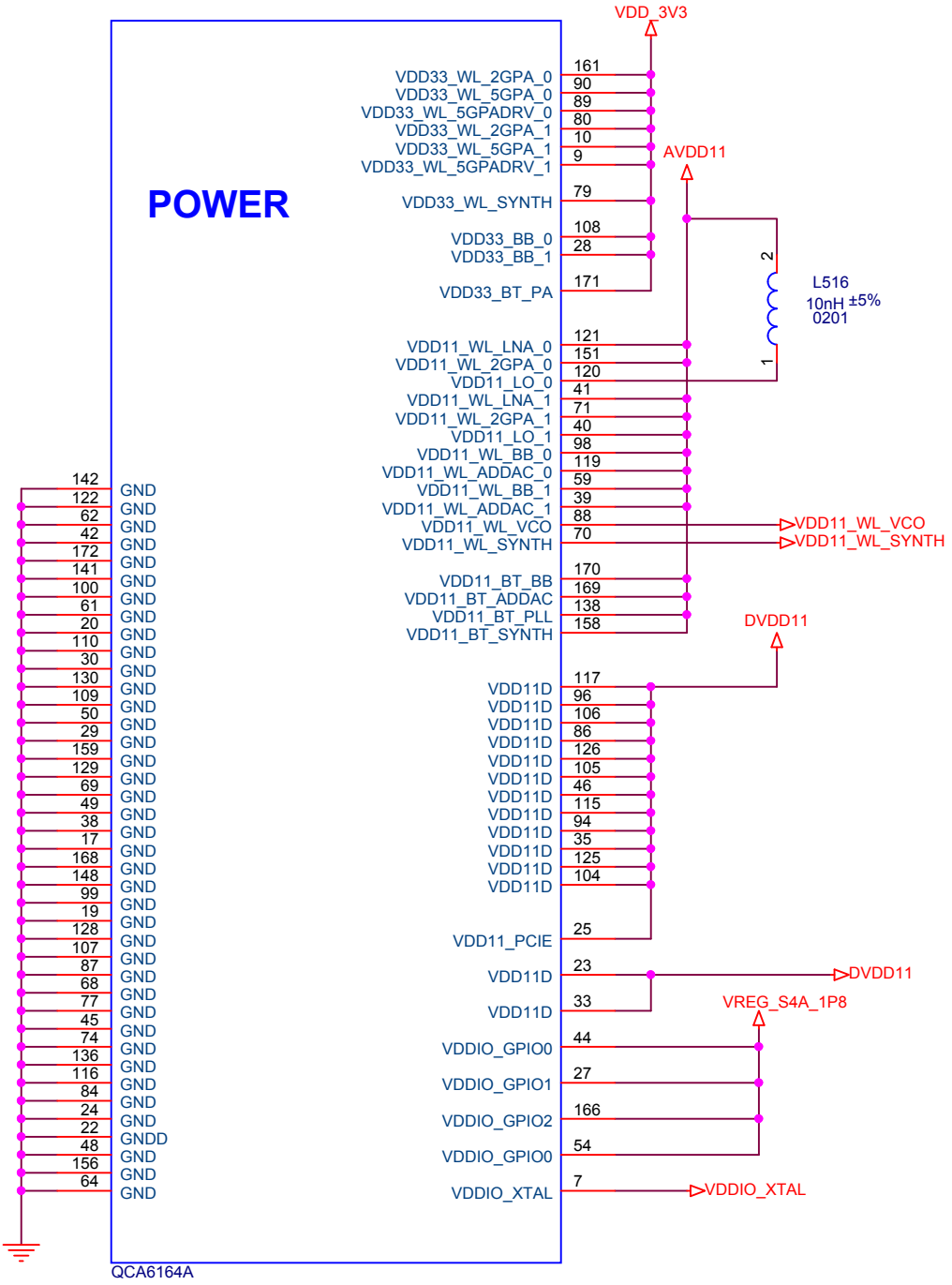

BT/FM/WLAN DECOUP

Title		
A1		
Size	Document Number	Rev
A3	<Doc>	P0
Date:	Wednesday, December 09, 2015	Sheet 10 of 37

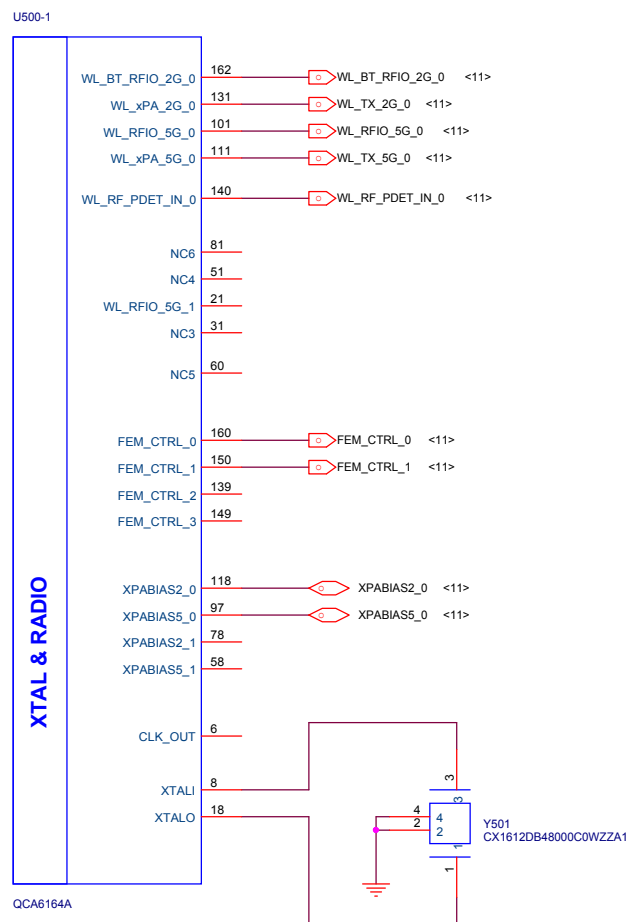
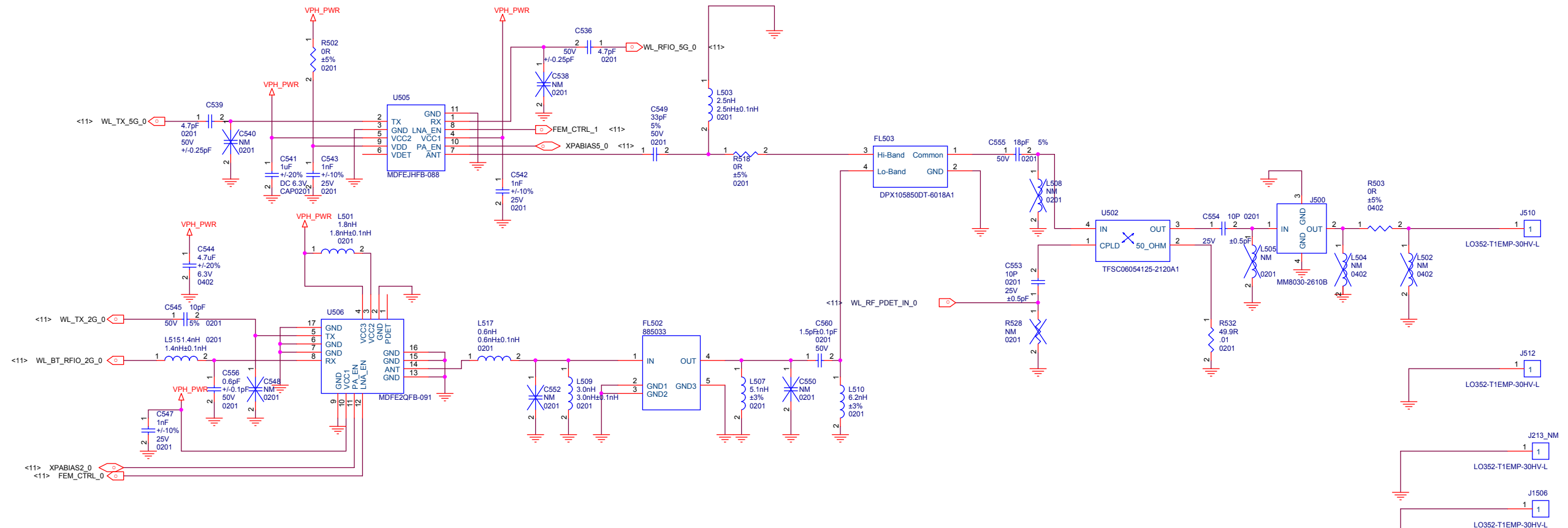

BT/WIFI FEM		
Title	A1	
Size	Document Number	Rev
A2	<Doc>	P0
Date:	Wednesday, December 09, 2015	Sheet 11 of 37

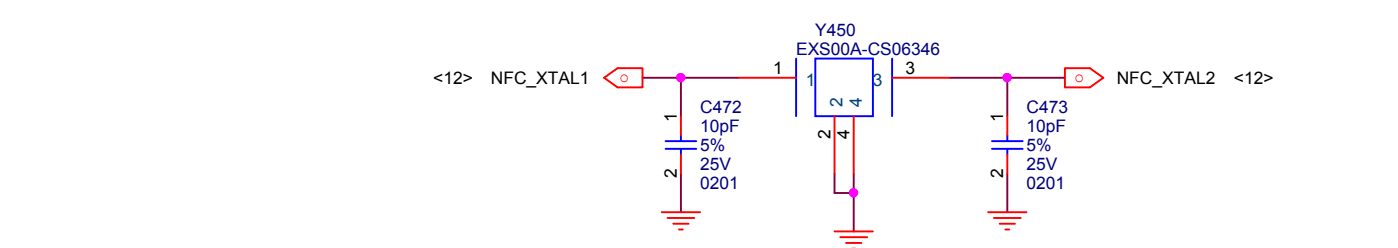
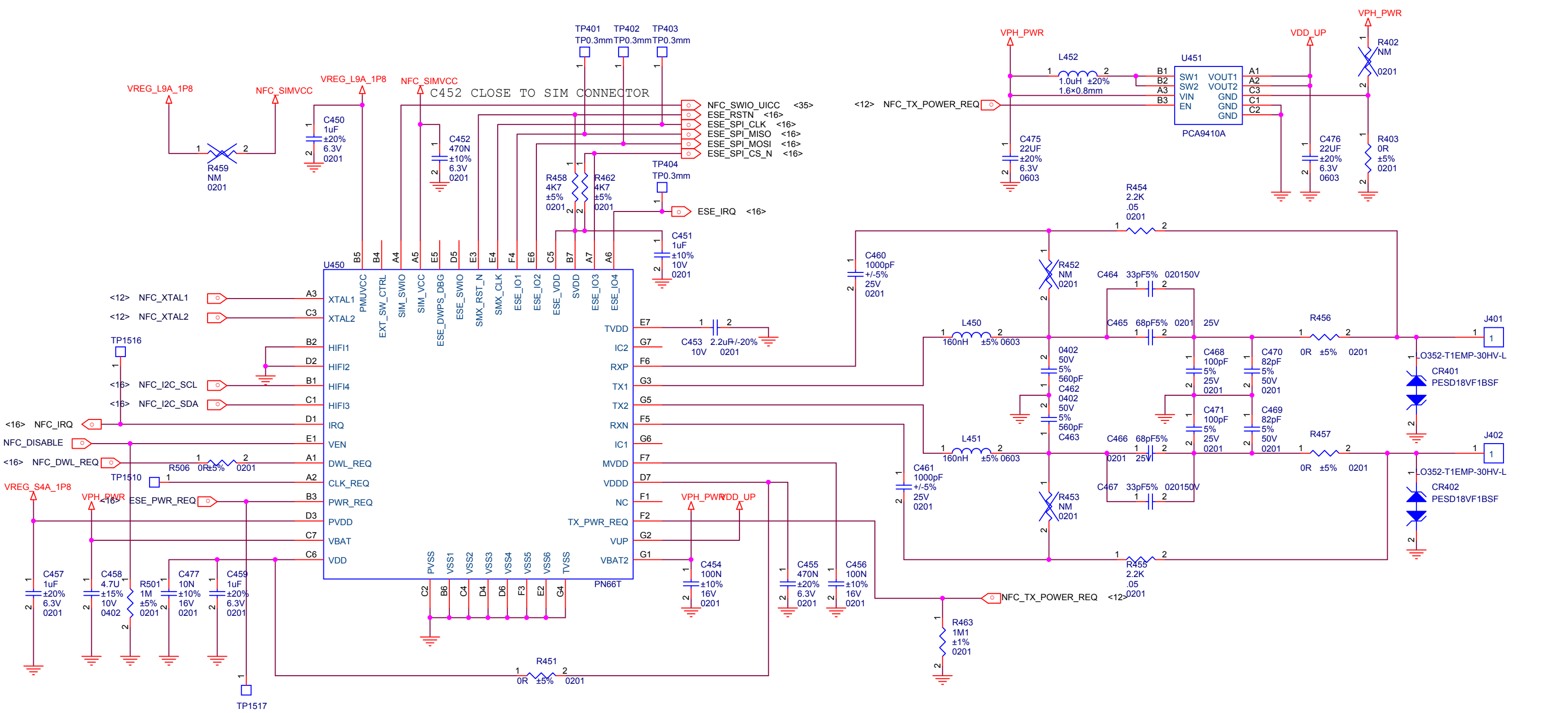

Title		
A1		
Size	Document Number	Rev
A3	<Doc>	P0
Date:	Wednesday, December 09, 2015	Sheet 12 of 37

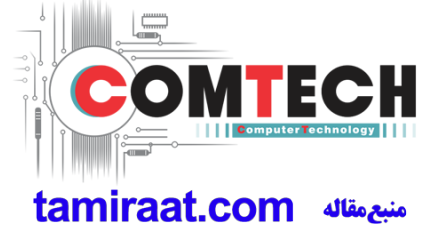
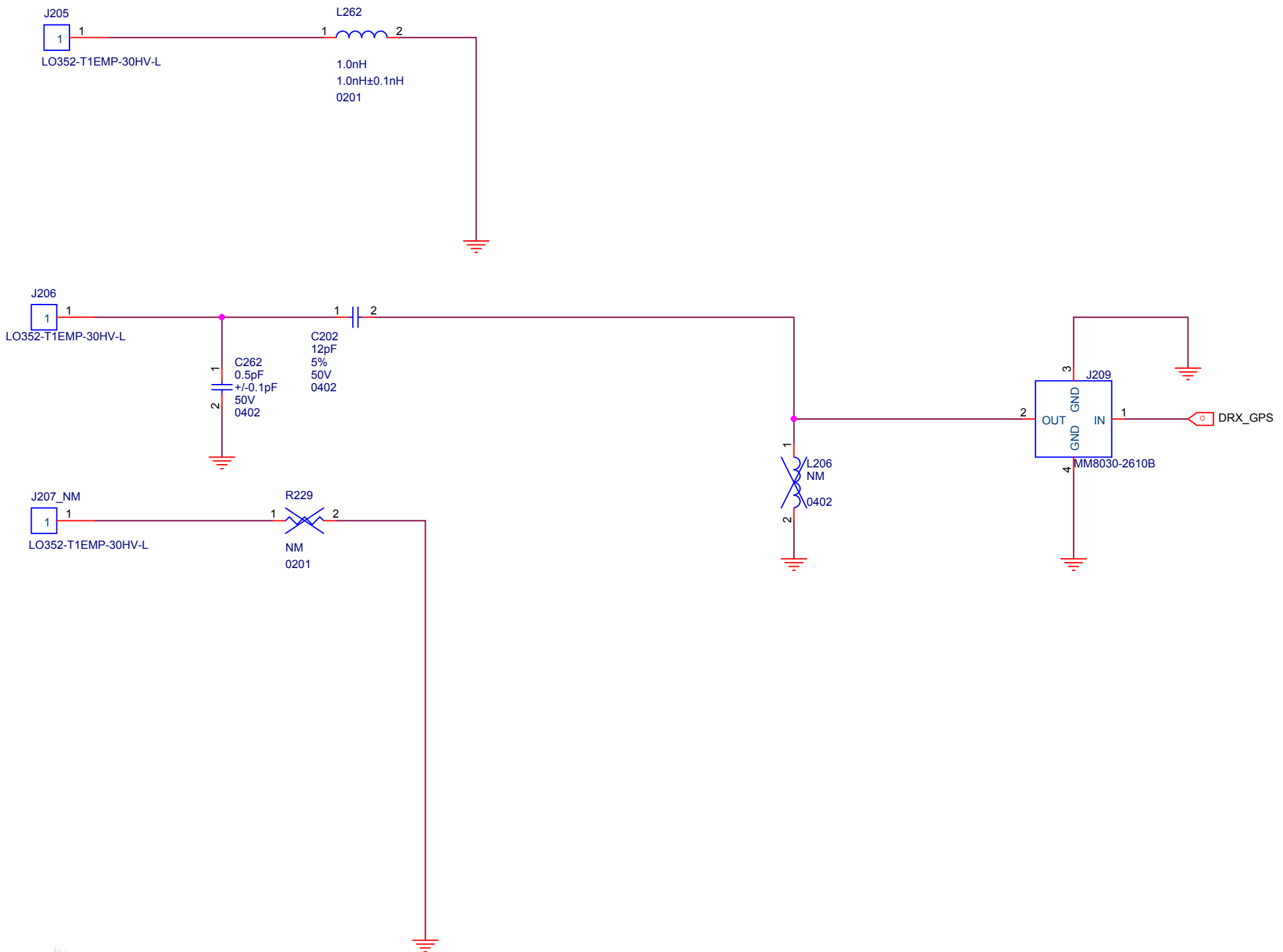

TUNER

Title		
A1		
Size	Document Number	Rev
A3	<Doc>	P0
Date:	Wednesday, December 09, 2015	Sheet 14 of 37

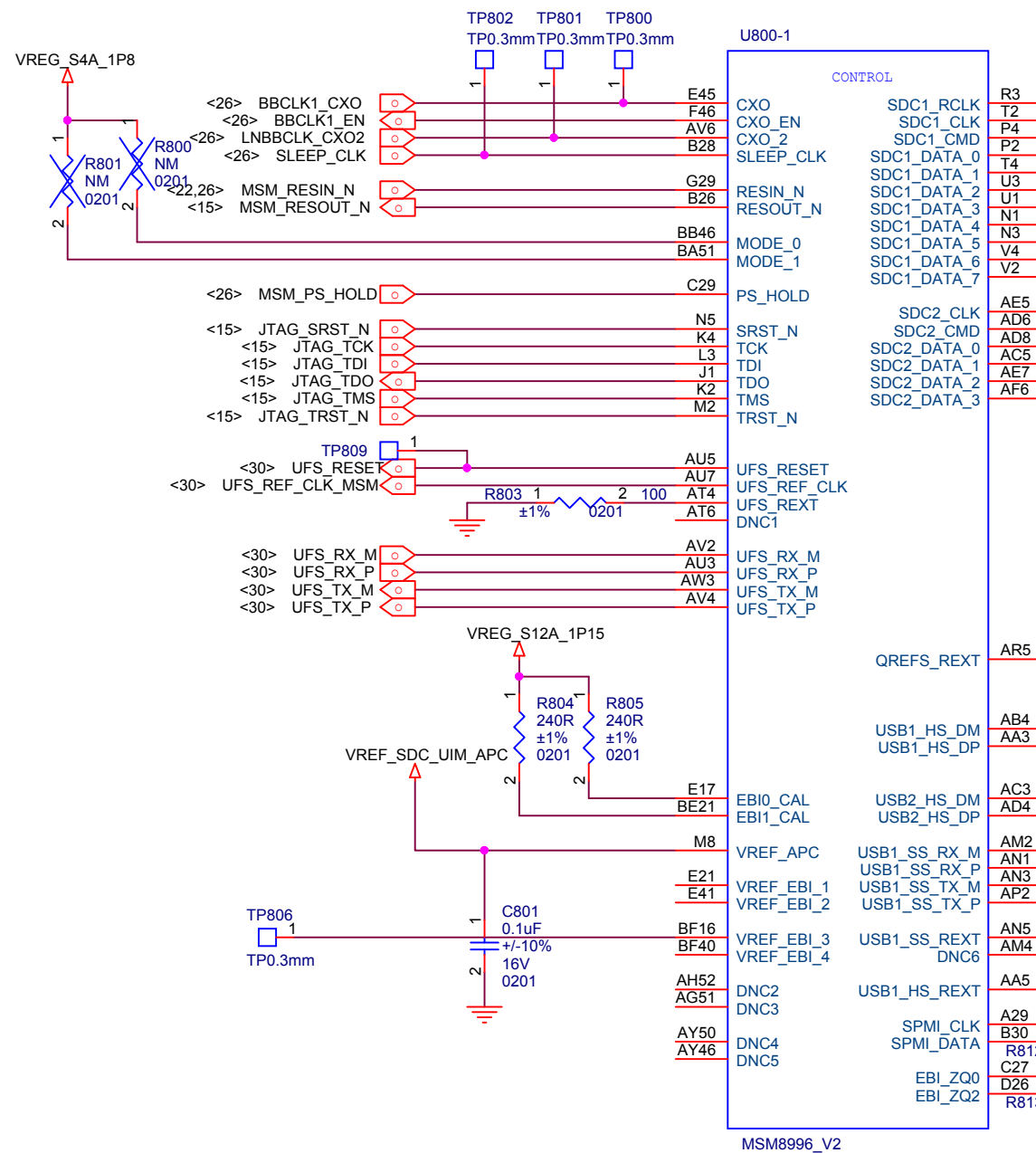

Note: Place all REXT resistors close to MSM

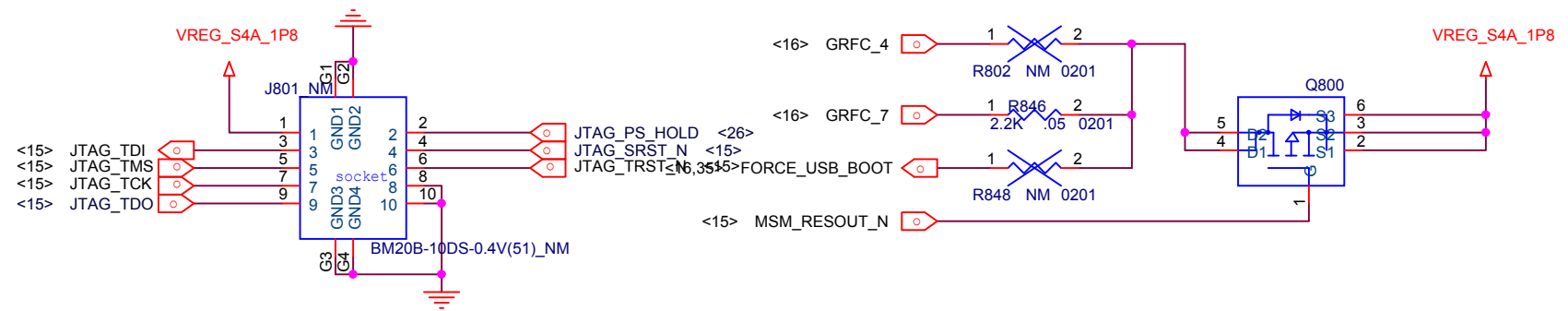

MSM8996 CONTROL

Title		
A1		
Size	Document Number	Rev
A3	<Doc>	P0
Date:	Wednesday, December 09, 2015	Sheet 15 of 37



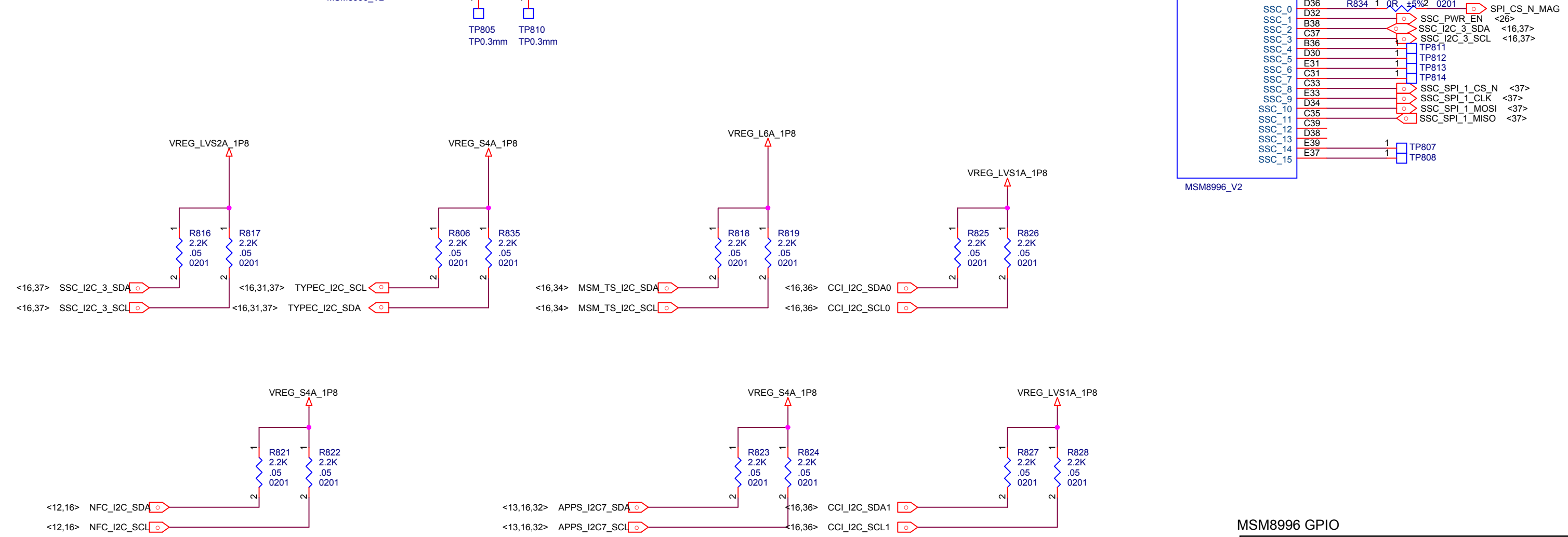
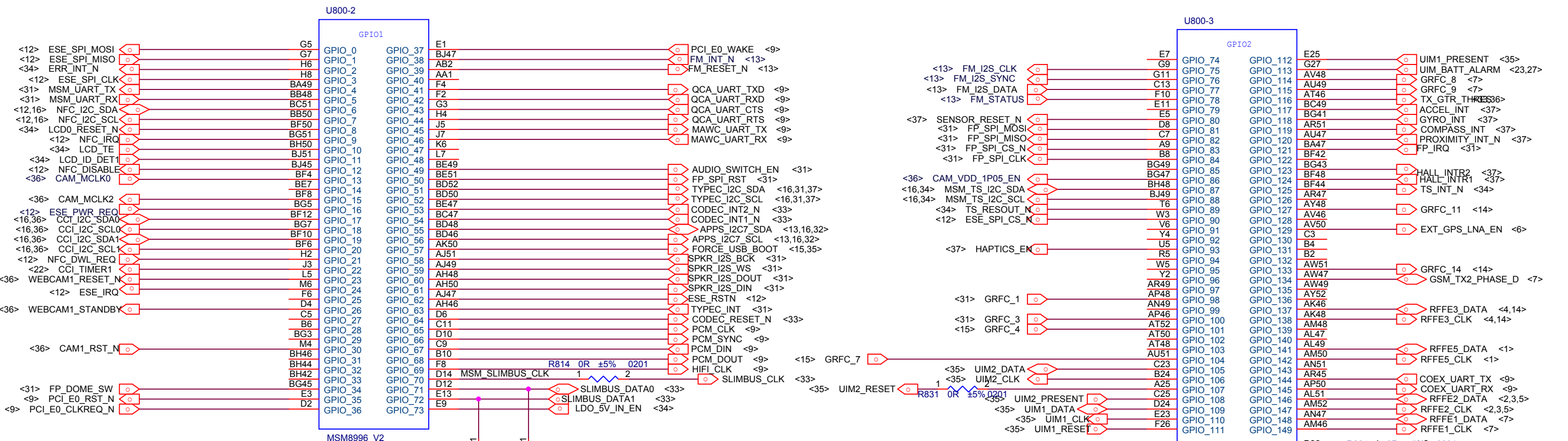

MSM8996 GPIO		
Title A1		
Size A3	Document Number <Doc>	Rev P0
Date:	Wednesday, December 09, 2015	Sheet 16 of 37

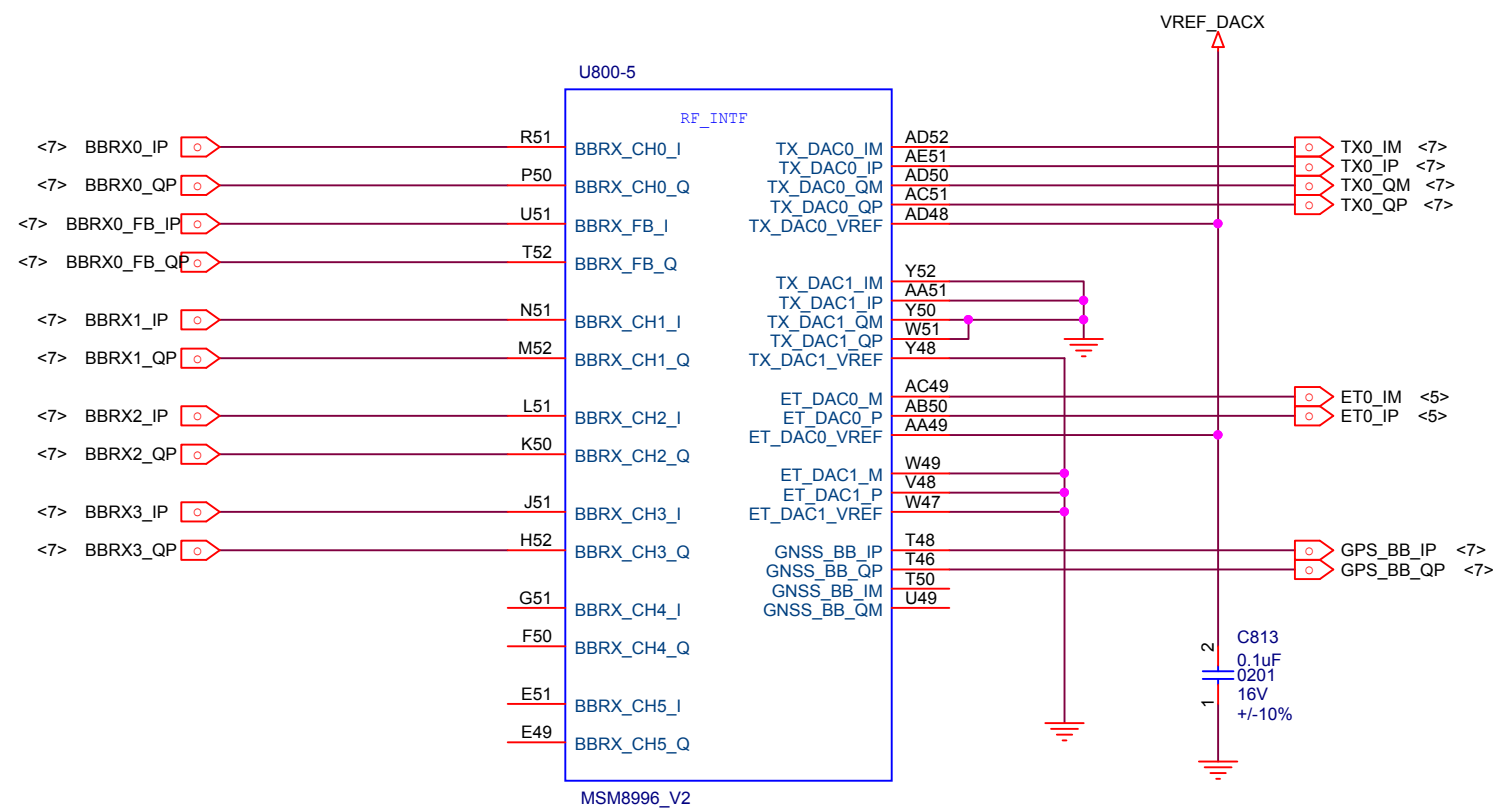
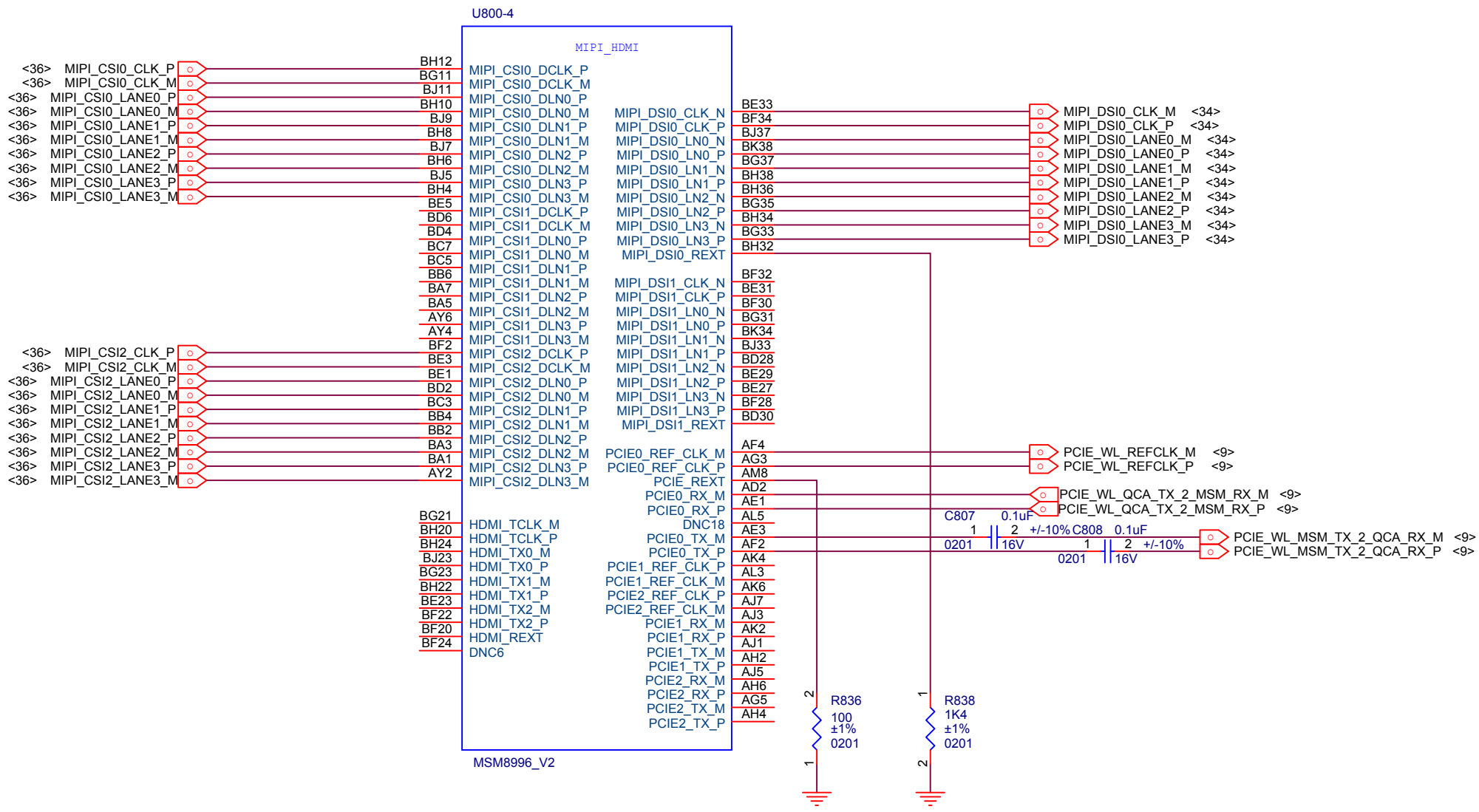

MSM8996 MIPI

Title		
A1		
Size	Document Number	Rev
A3	<Doc>	P0
Date:	Wednesday, December 09, 2015	Sheet 17 of 37



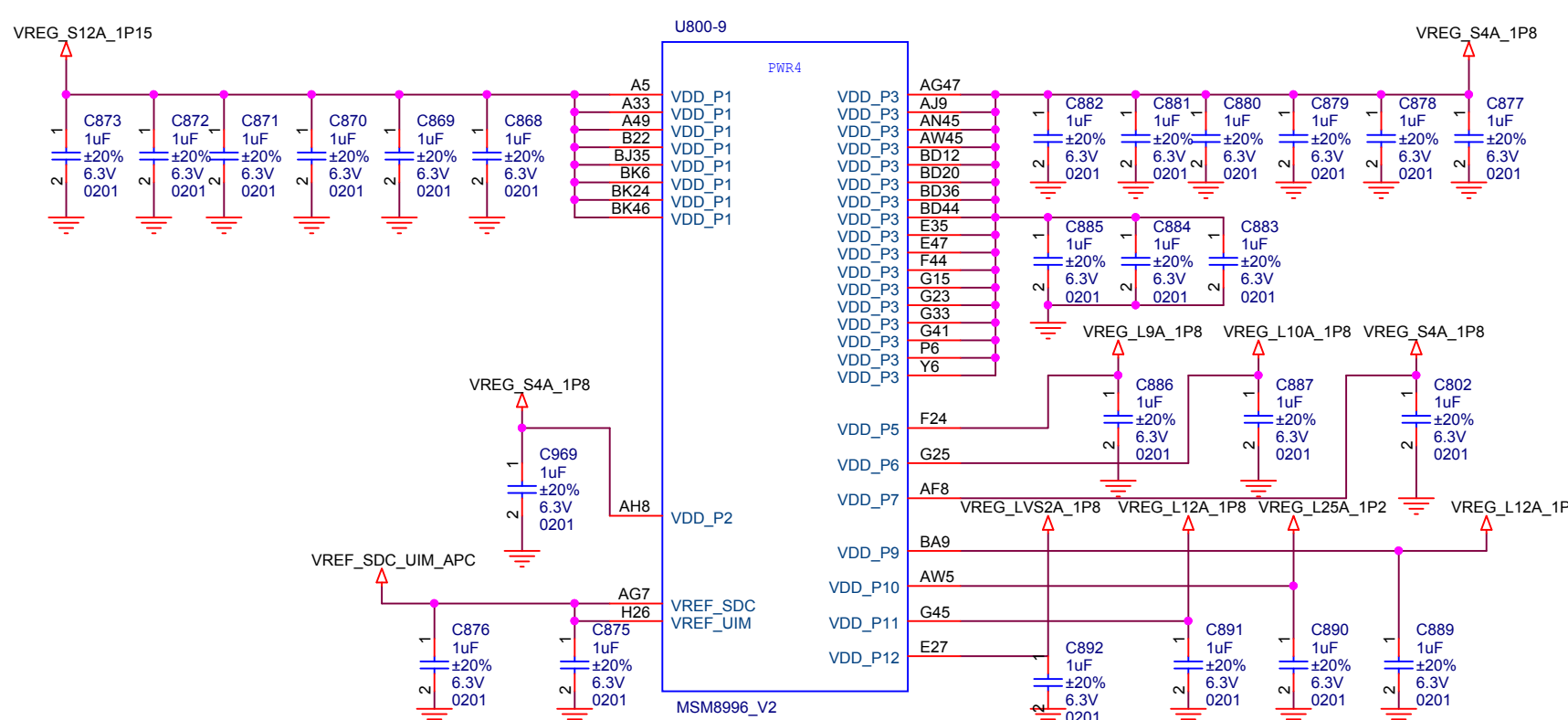
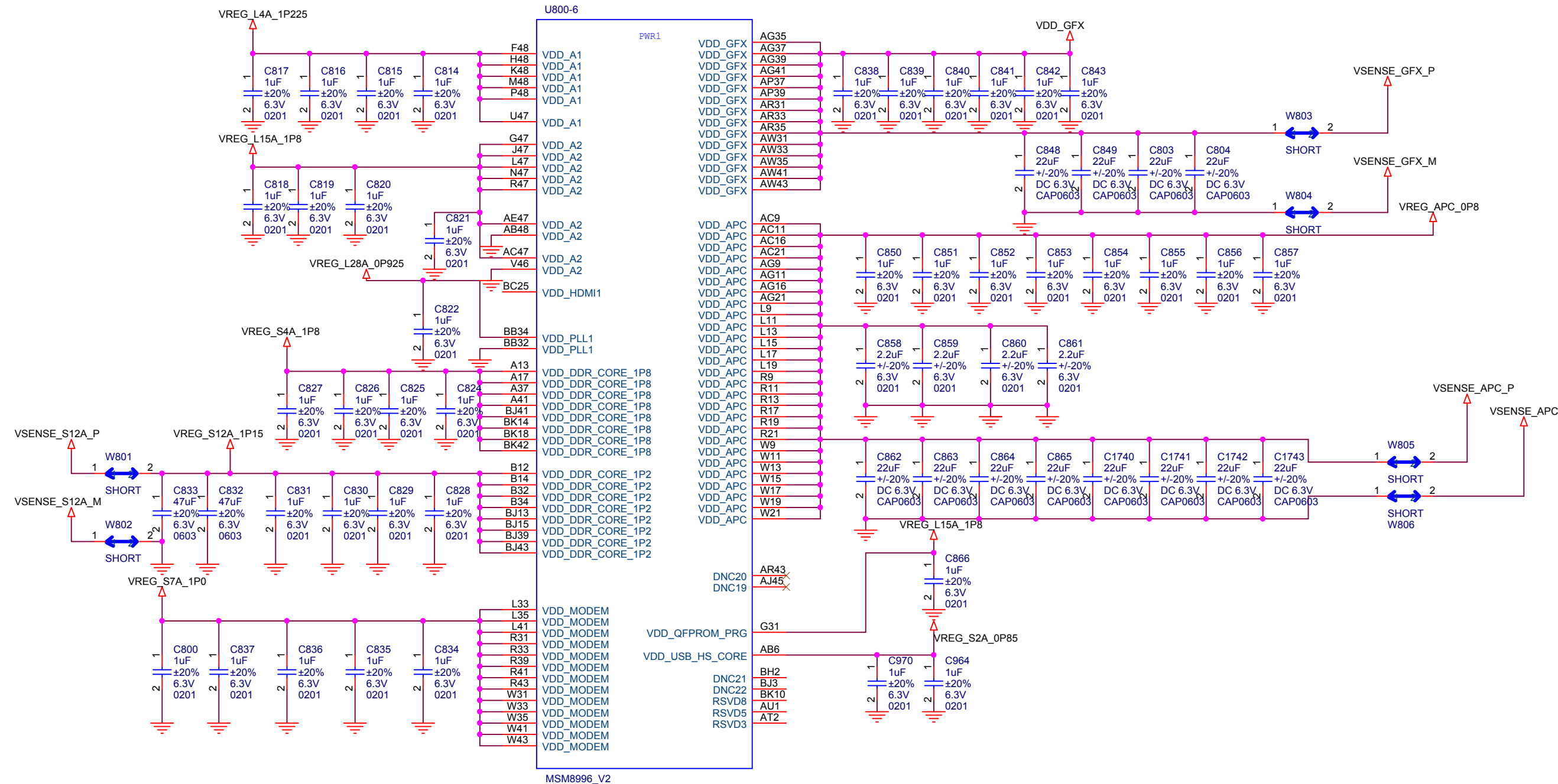

MSM8996 PWR1

Title		A1
Size	Document Number	Rev
A3	<Doc>	P0
Date:	Wednesday, December 09, 2015	Sheet 18 of 37



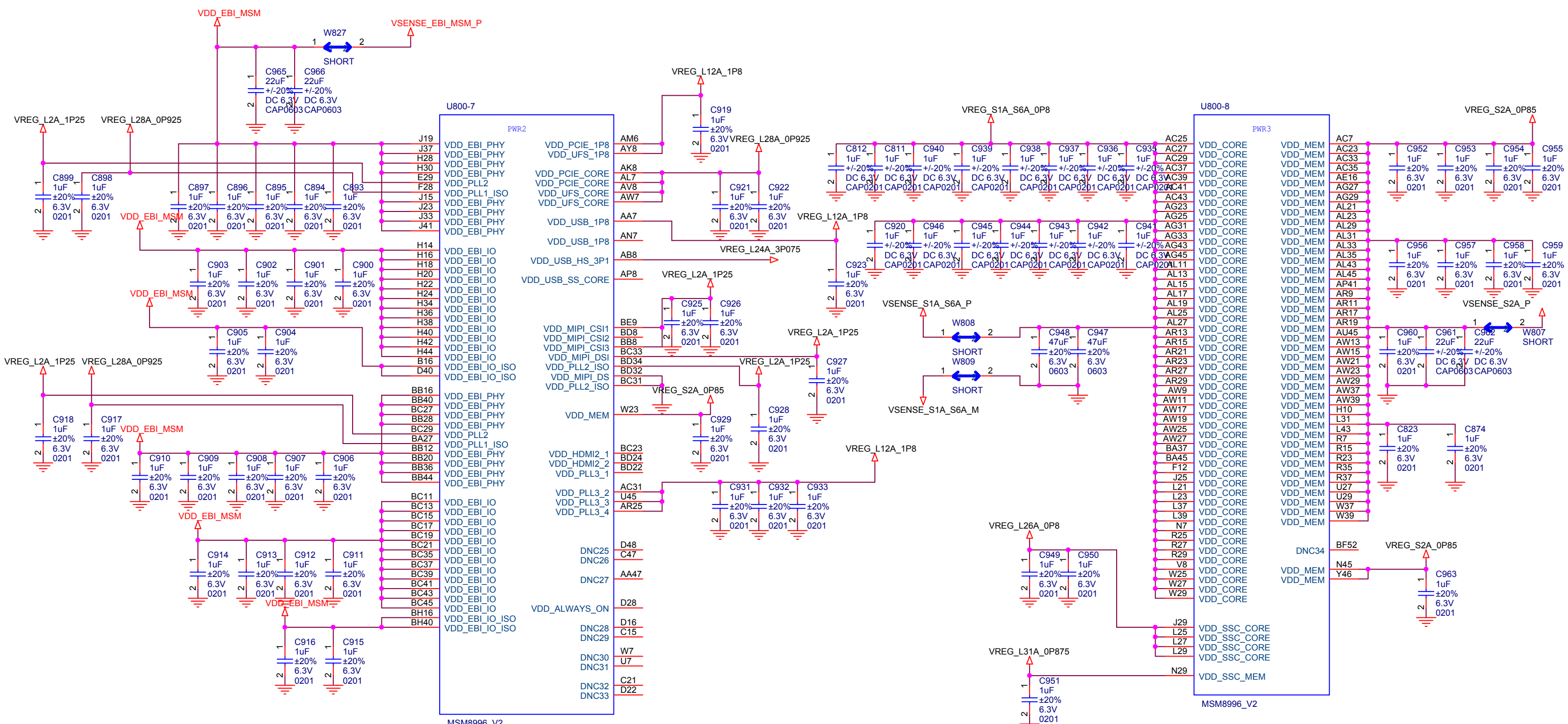

MSM8996 PWR2

Title			A1
Size	Document Number	Rev	
A3	<Doc>	P0	
Date:	Wednesday, December 09, 2015	Sheet	19 of 37

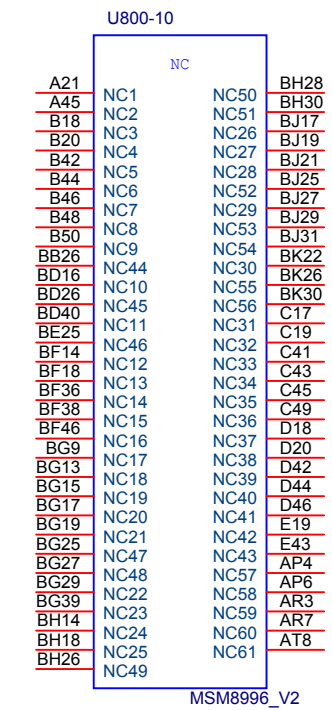
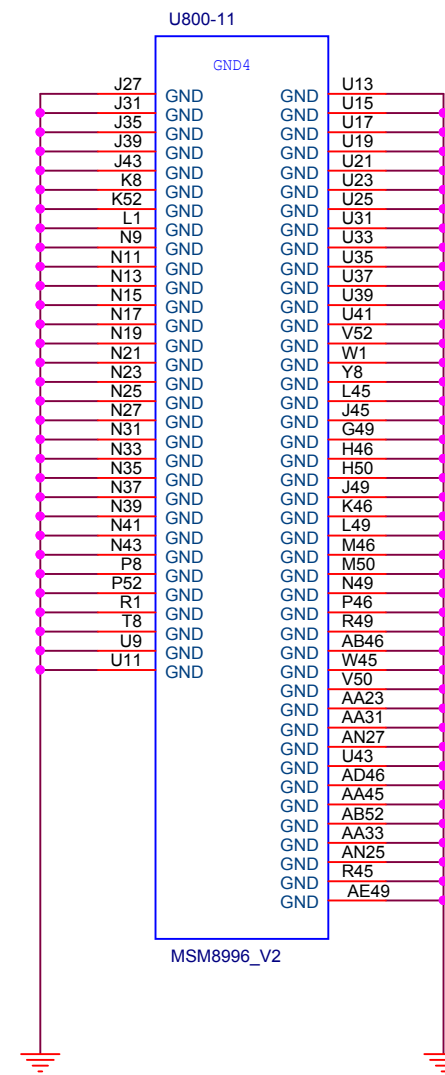
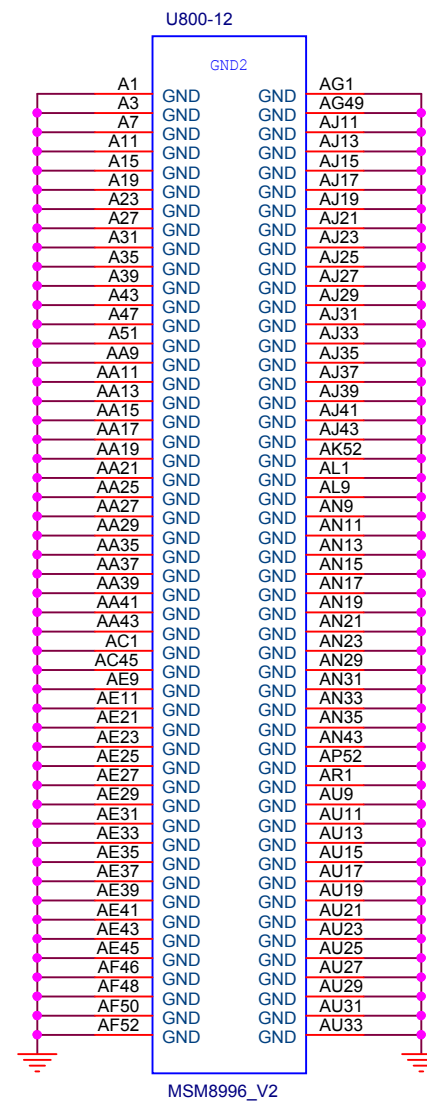
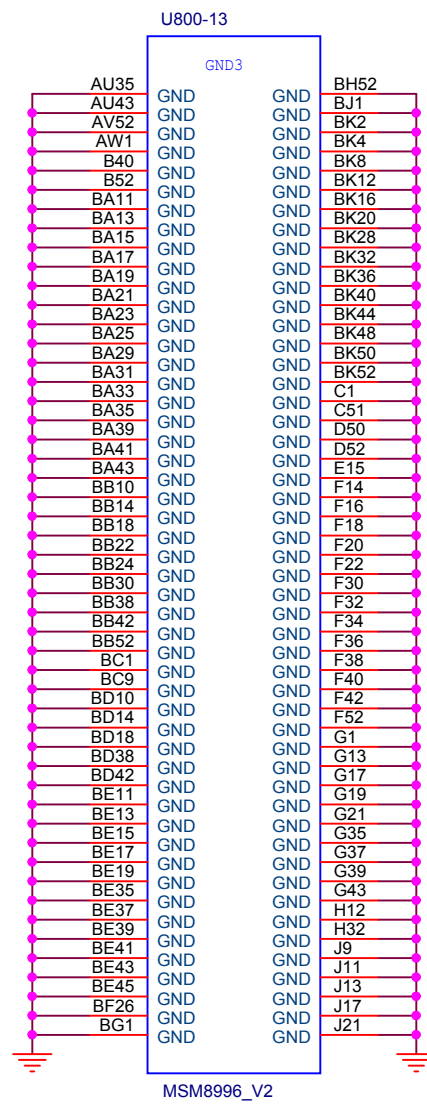

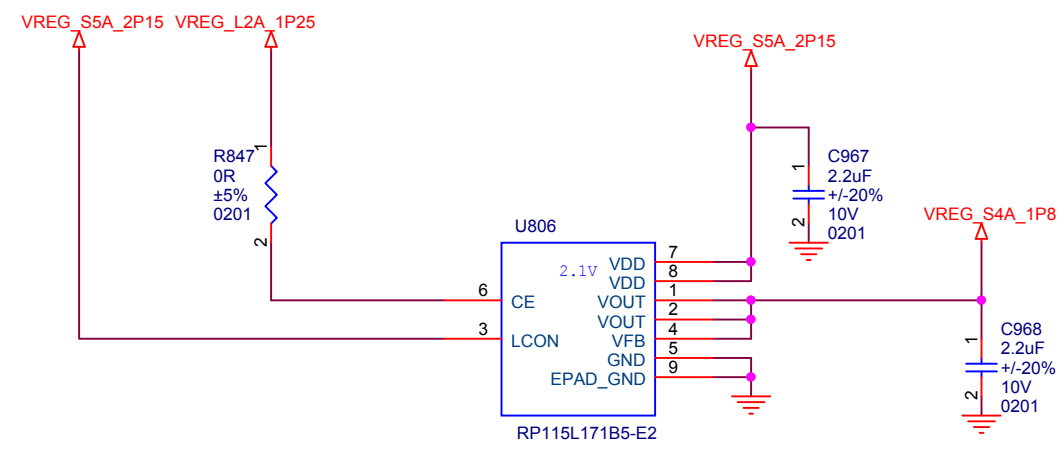

MSM8996 LPDDR REGULATOR

Title		
A1		
Size	Document Number	Rev
A3	<Doc>	P0
Date:	Wednesday, December 09, 2015	Sheet 21 of 37

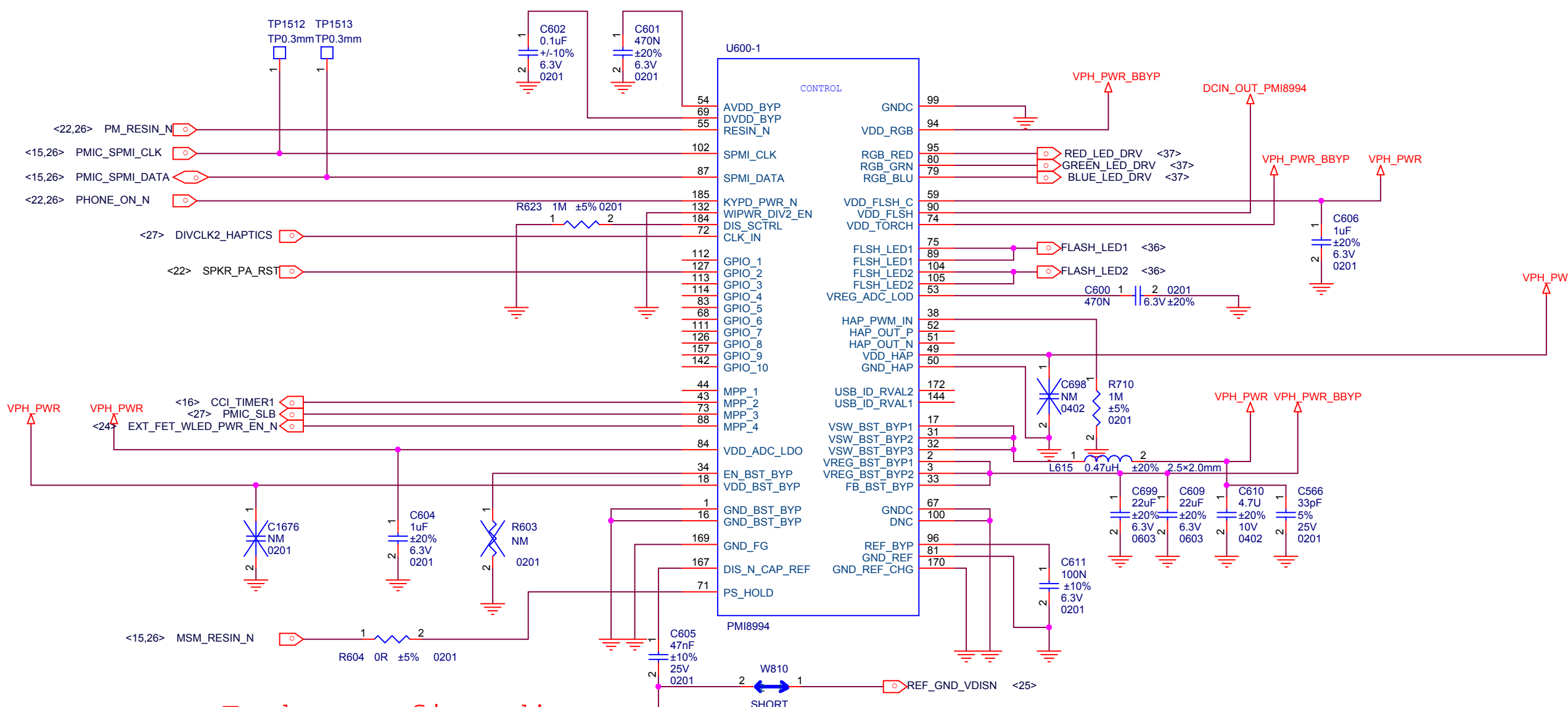

To be confirmed!

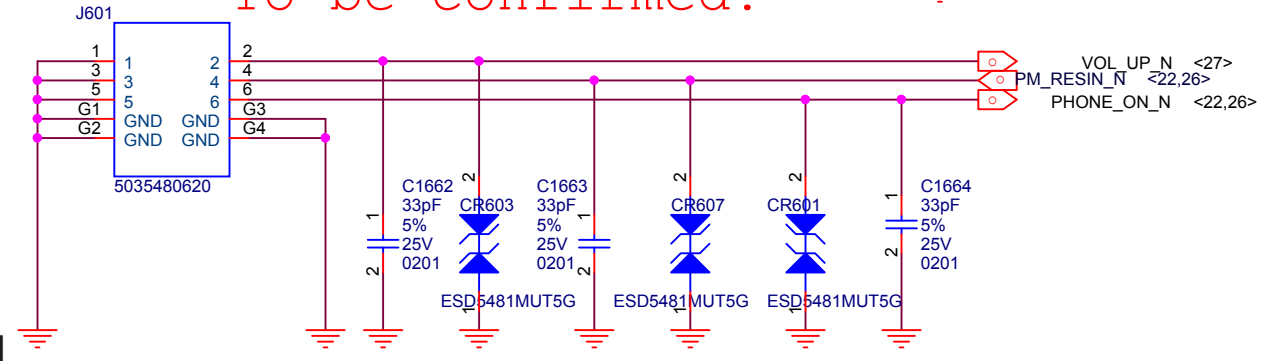

PMI8994 CONTROL

Title		
A1		
Size	Document Number	Rev
A3	<Doc>	P0
Date:	Wednesday, December 09, 2015	Sheet 22 of 37



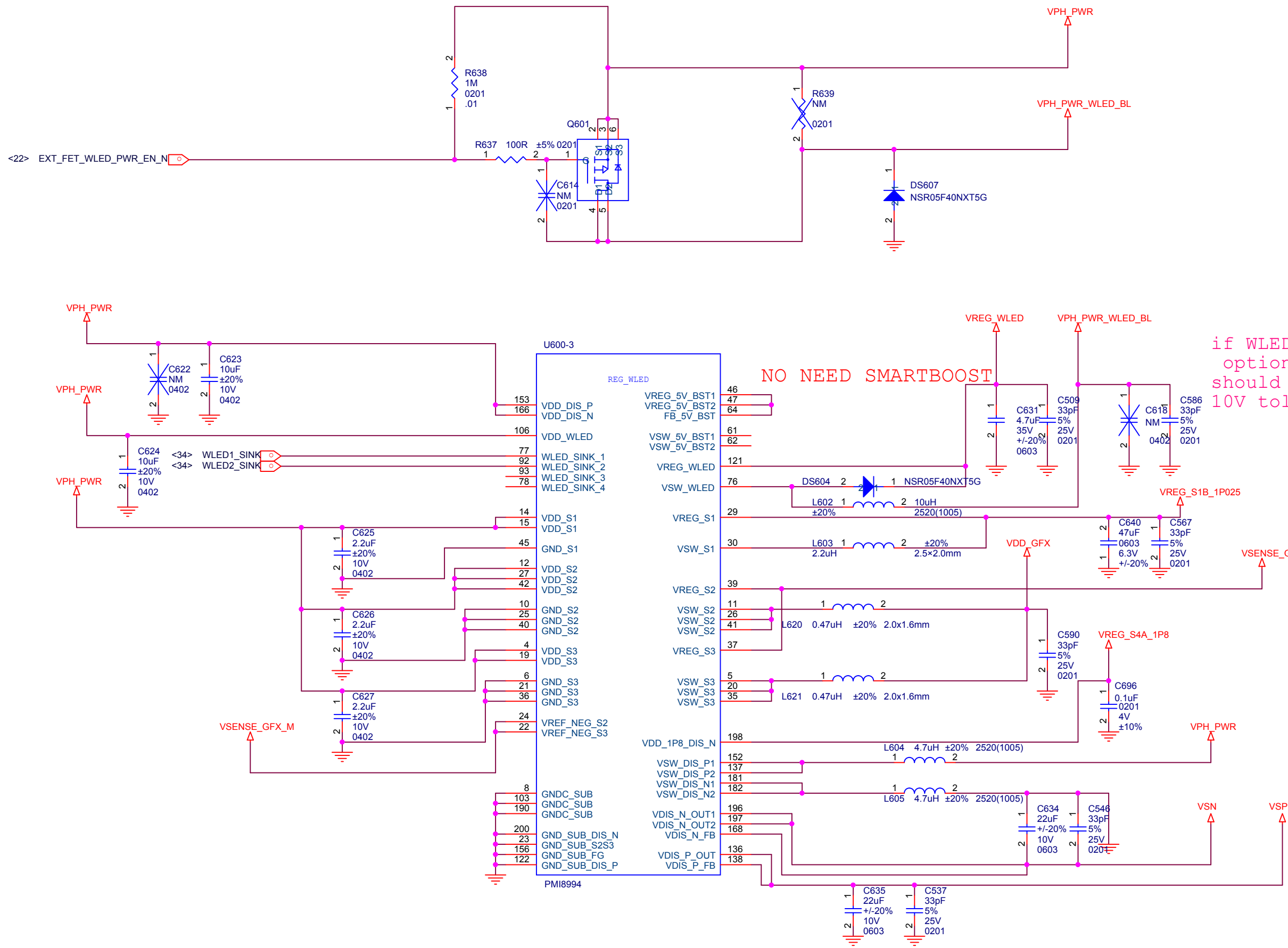

NO NEED SMARTBOOST

if WLED short circuit protection option is not used, C1670 should be changed to 10uF, 10V tolerance capacitor



PMI8994 REG WLED		
Title A1		
Size A3	Document Number <Doc>	Rev P0
Date:	Wednesday, December 09, 2015	Sheet 24 of 37

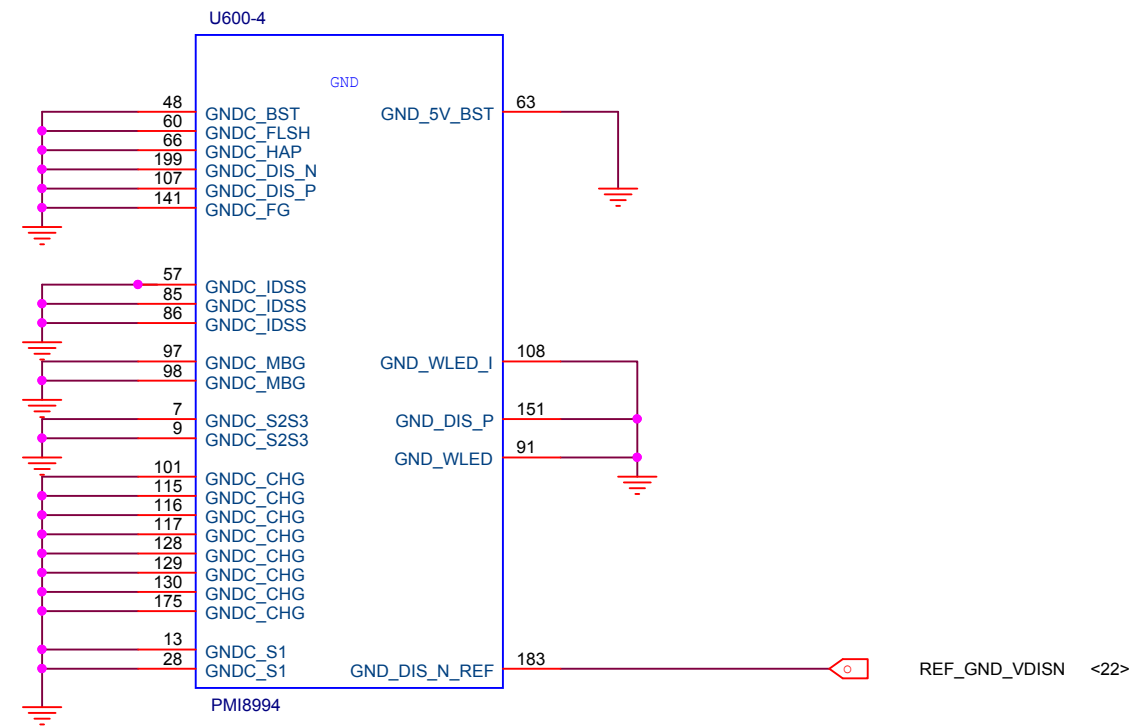

CAD NOTE: Connect to pin183 then GND with single via

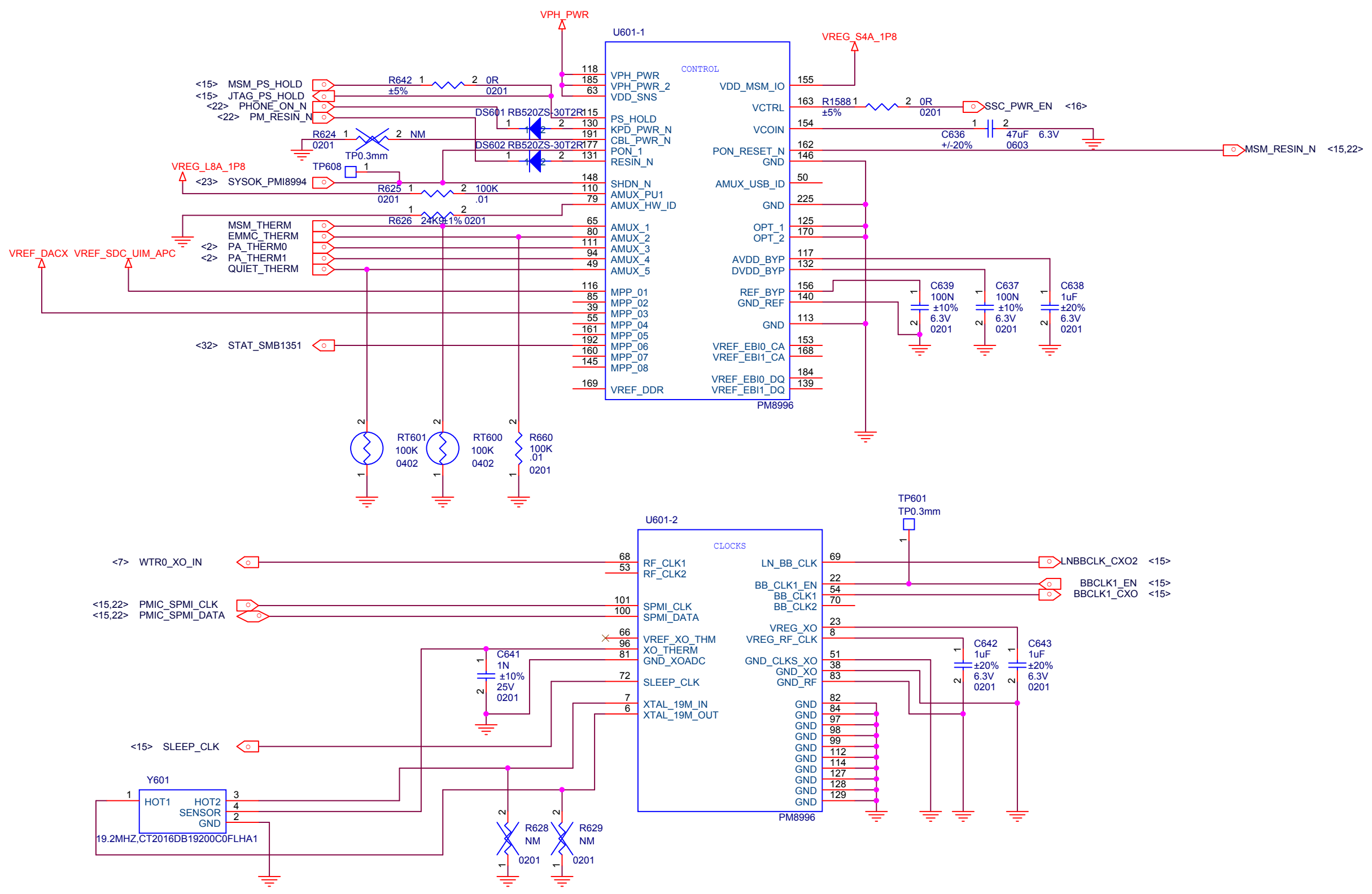

PM8996 CONTROL

Title		
A1		
Size	Document Number	Rev
A3	<Doc>	P0
Date:	Wednesday, December 09, 2015	Sheet 26 of 37



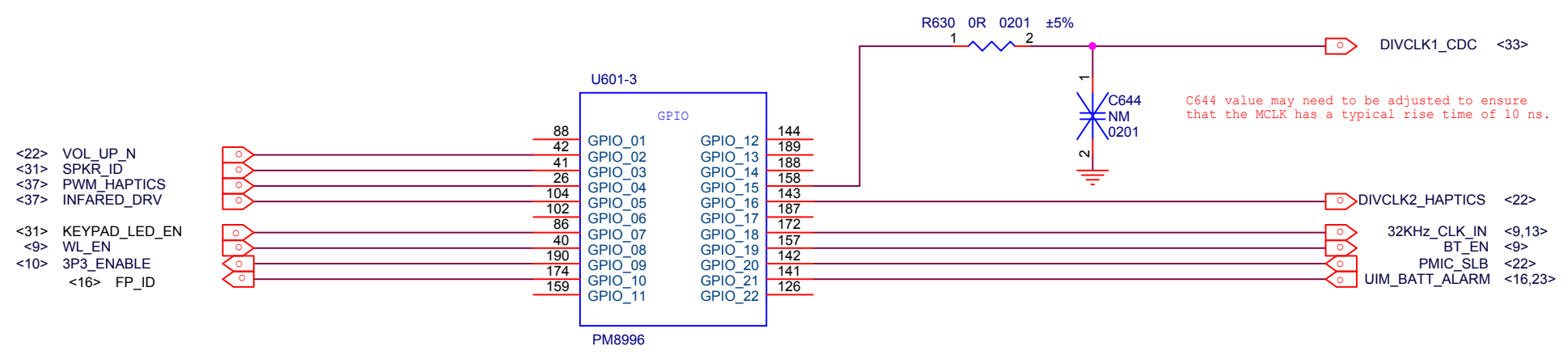

- <22> VOL_UP_N
- <31> SPKR_ID
- <37> PWM_HAPTICS
- <37> INFARED_DRV
- <31> KEYPAD_LED_EN
- <9> WL_EN
- <10> 3P3_ENABLE
- <16> FP_ID



PM8996 GPIO

Title		
A1		
Size	Document Number	Rev
A3	<Doc>	P0
Date:	Wednesday, December 09, 2015	Sheet 27 of 37

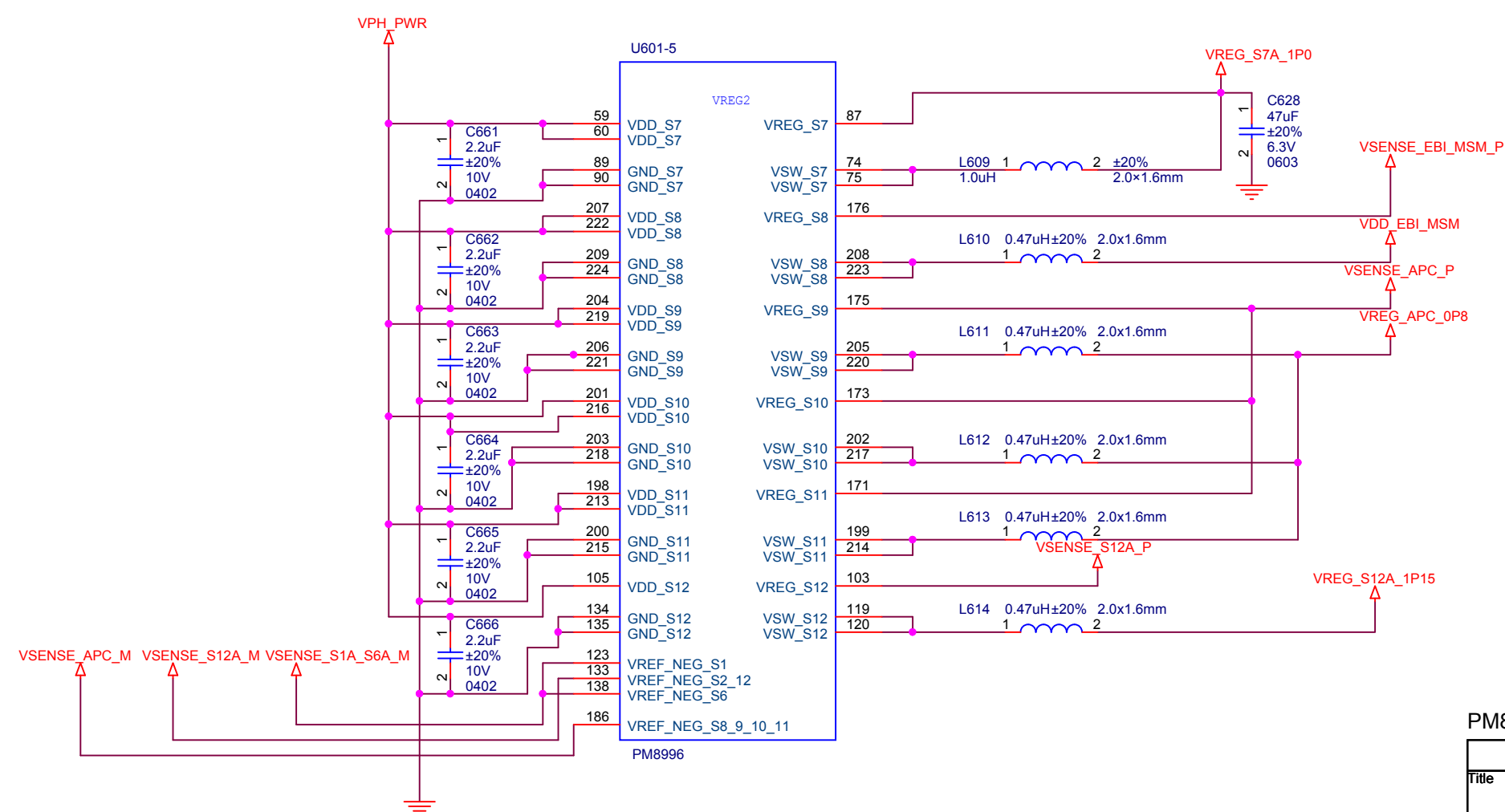
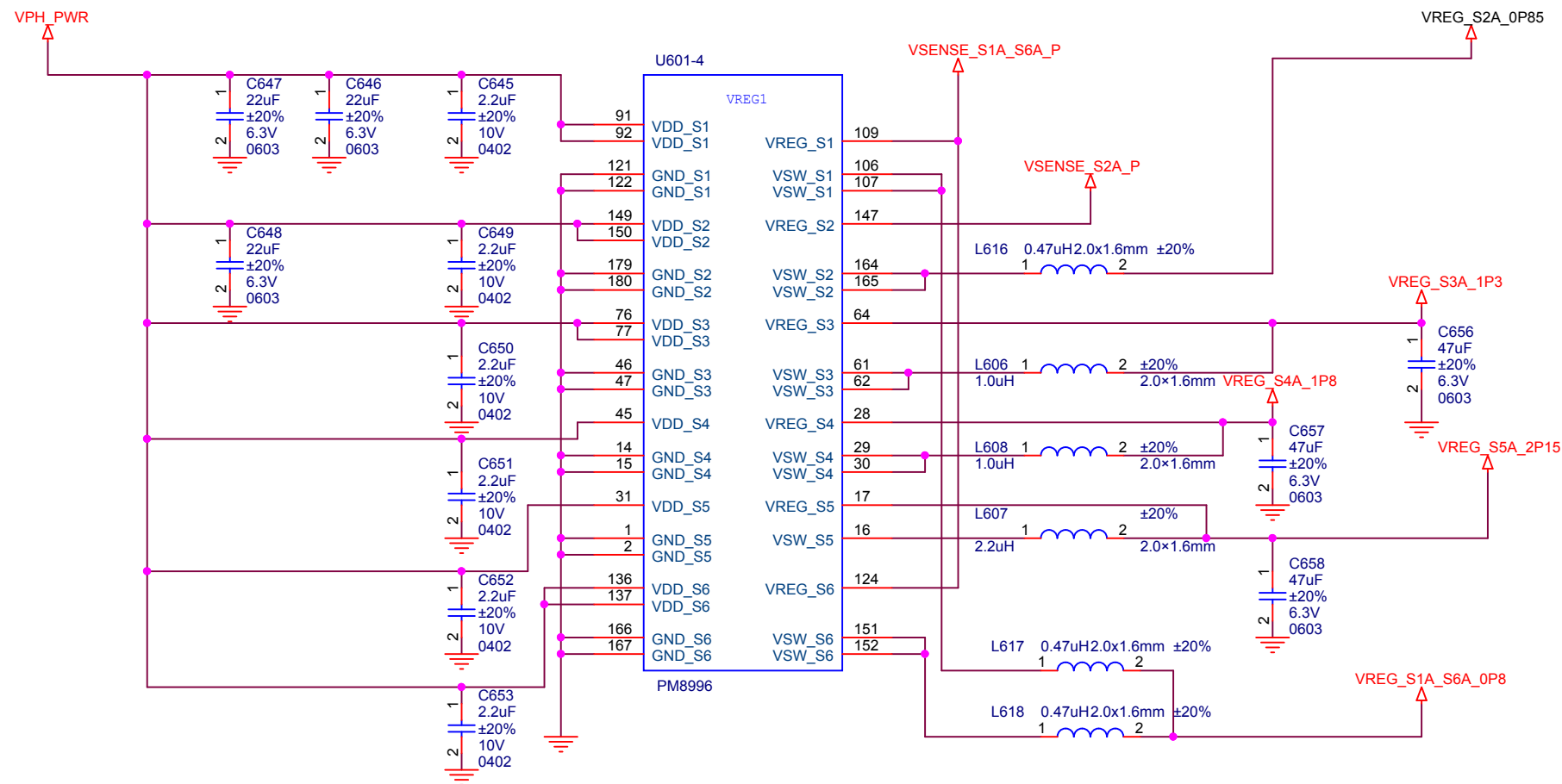

PM8996 VREG

Title		
A1		
Size	Document Number	Rev
A3	<Doc>	P0
Date:	Wednesday, December 09, 2015	Sheet 28 of 37



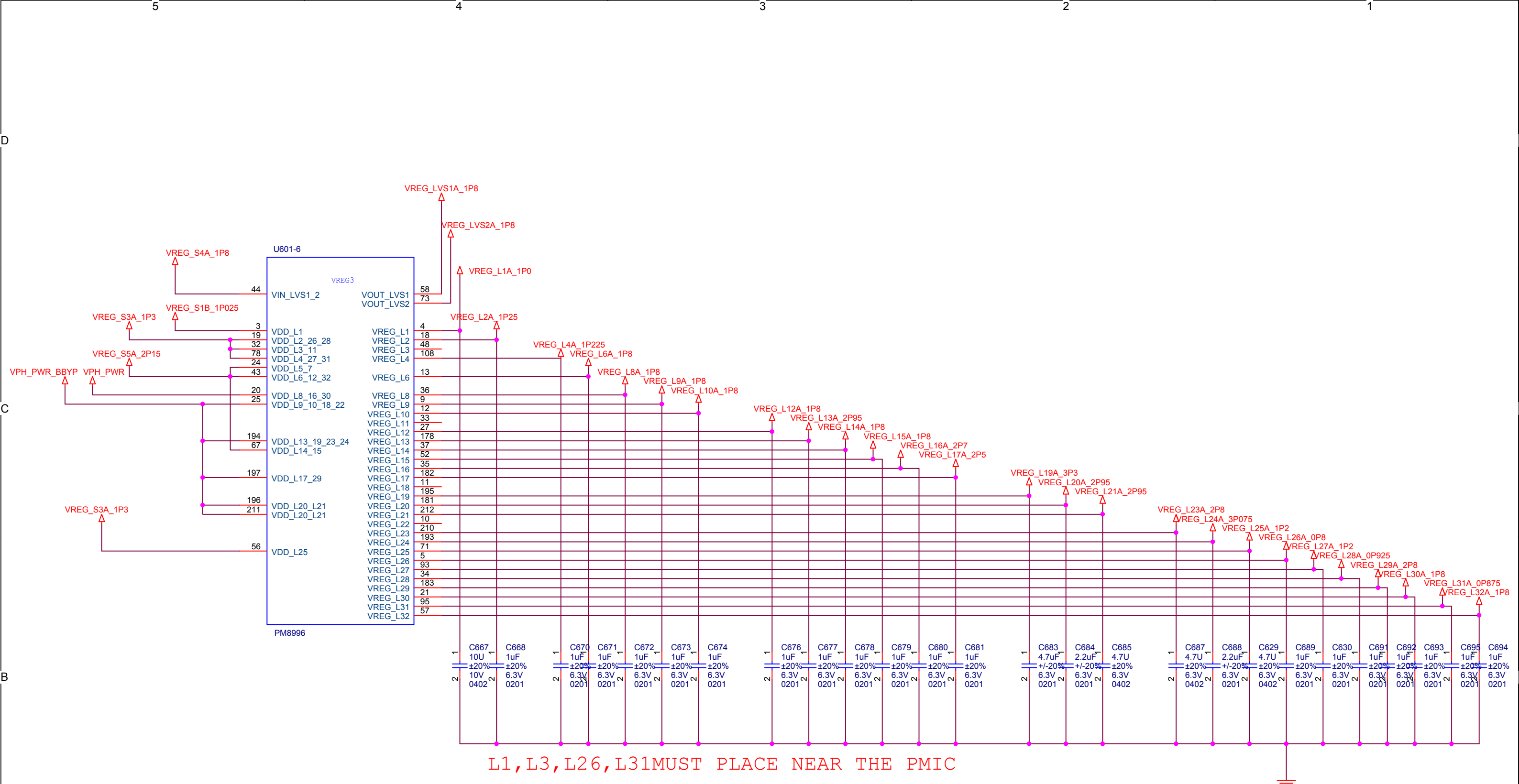

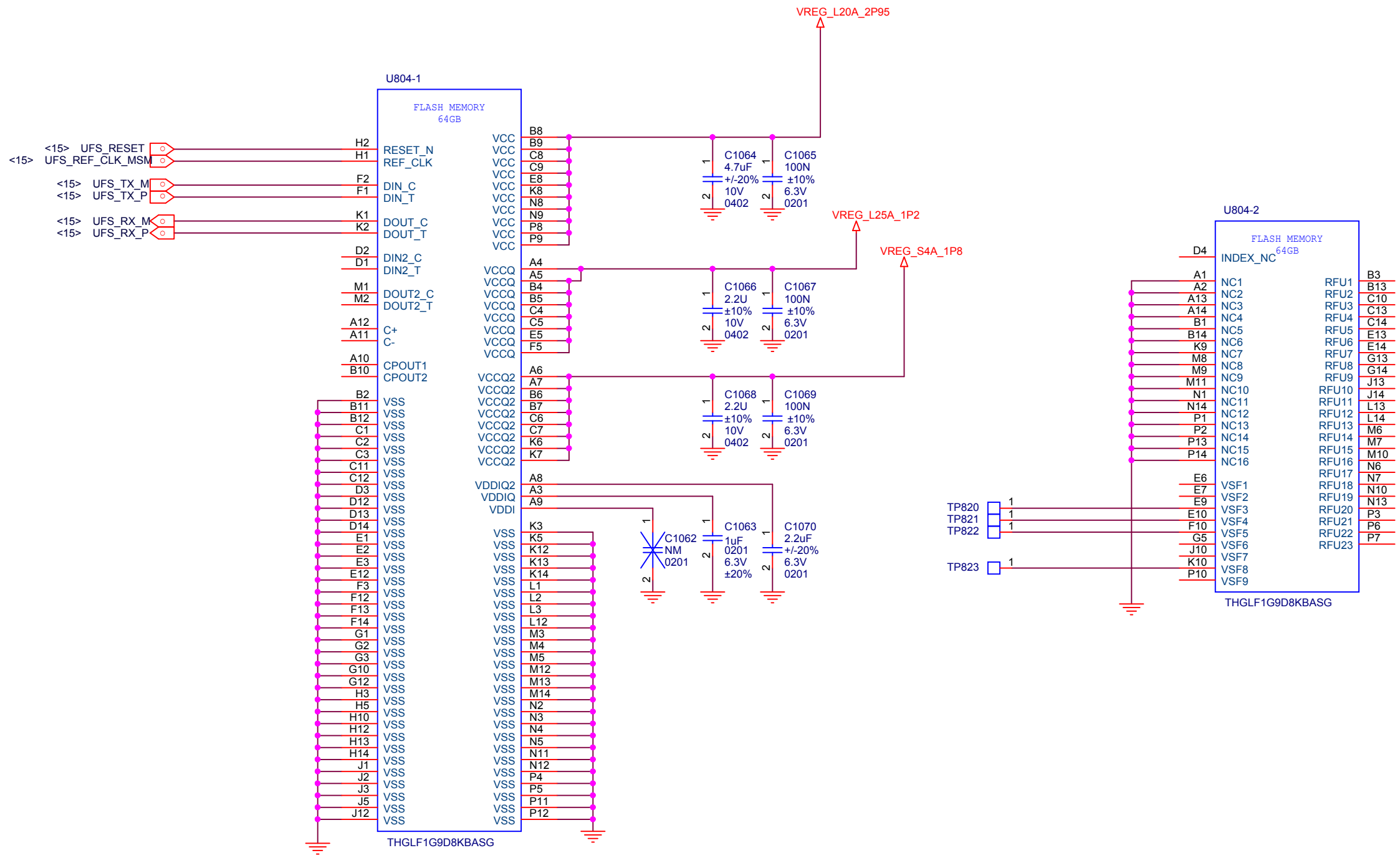

MEMORY UFS

Title		A1
Size	Document Number	Rev
A3	<Doc>	P0
Date:	Wednesday, December 09, 2015	Sheet 30 of 37

HANDSET

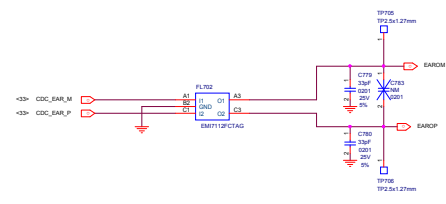

AUX Mic2

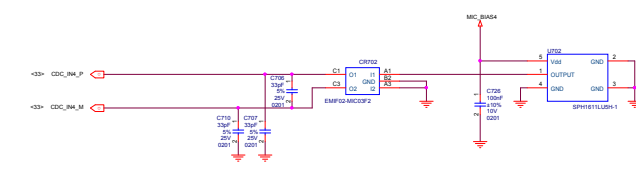

HEADSET

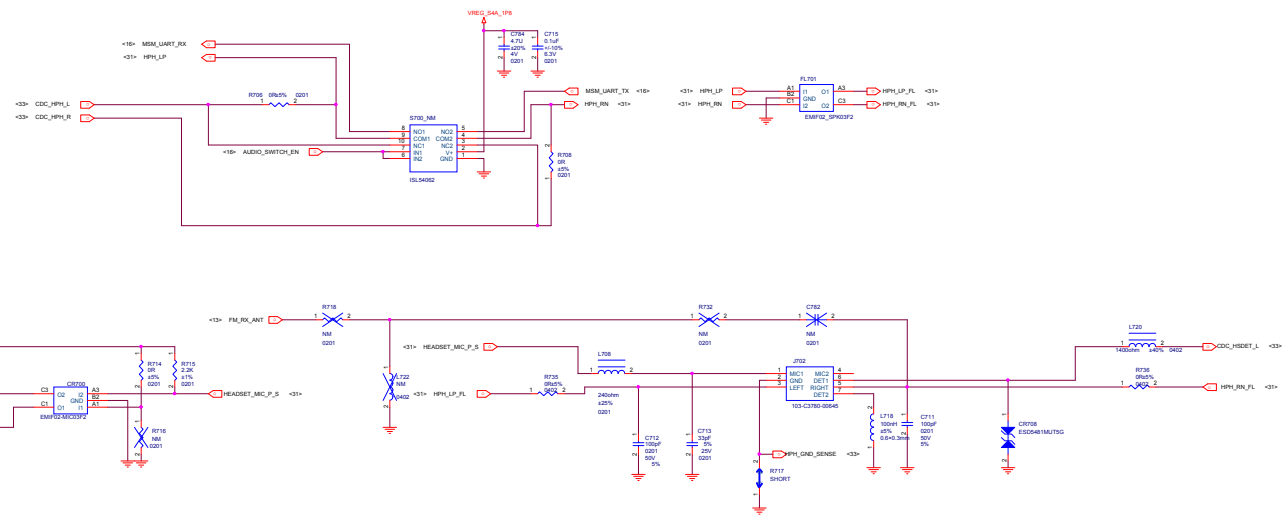

Speaker PA

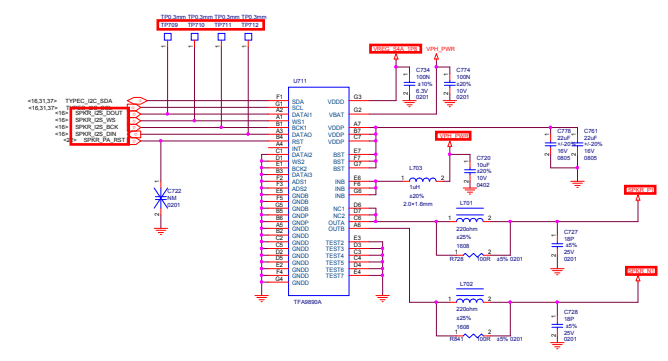

AUX Mic1

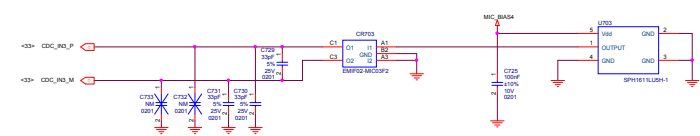

KEYPAD LED DRIVER

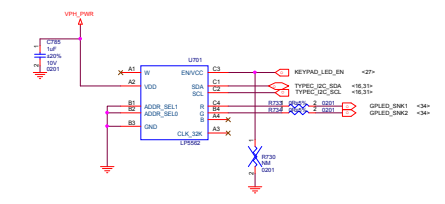

Bottom fpc Connector

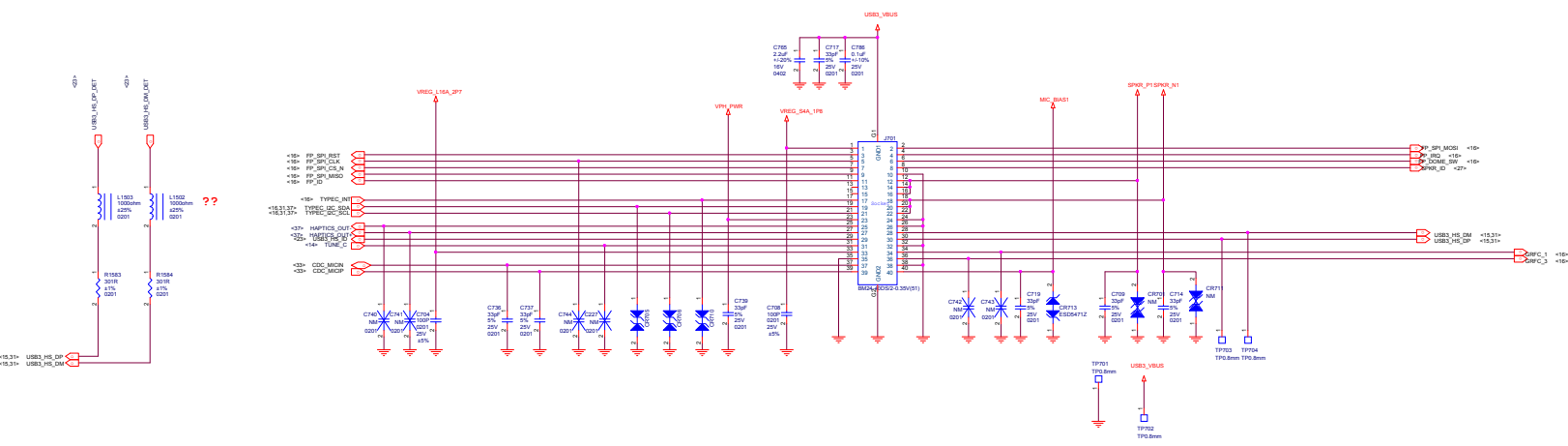

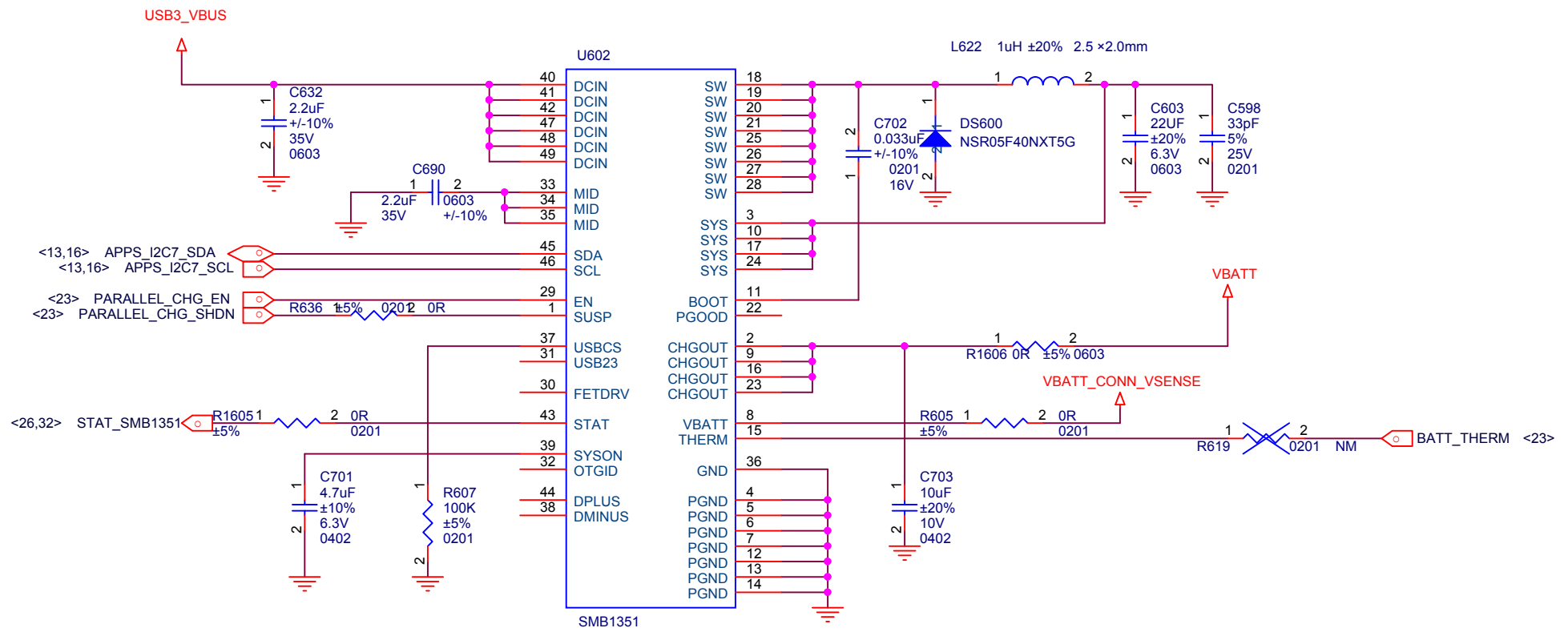

SMB1357 CHARGER

Title		A1
Size	Document Number	Rev
A3	<Doc>	P0
Date:	Wednesday, December 09, 2015	Sheet 32 of 37

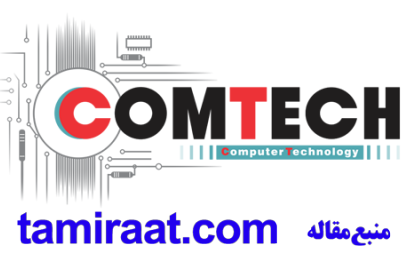
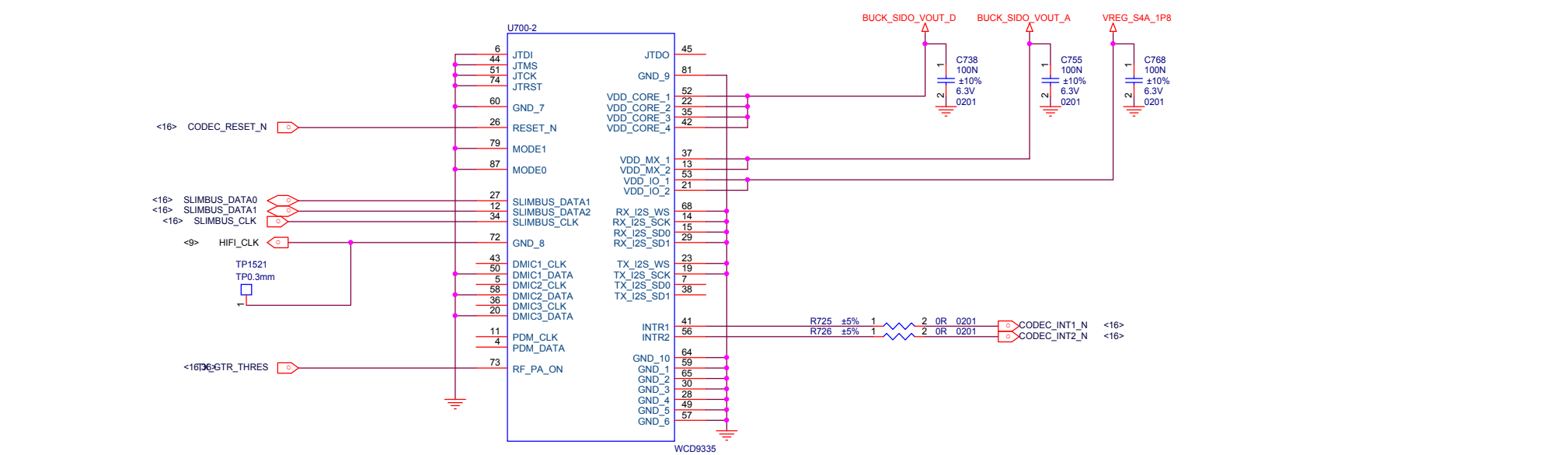
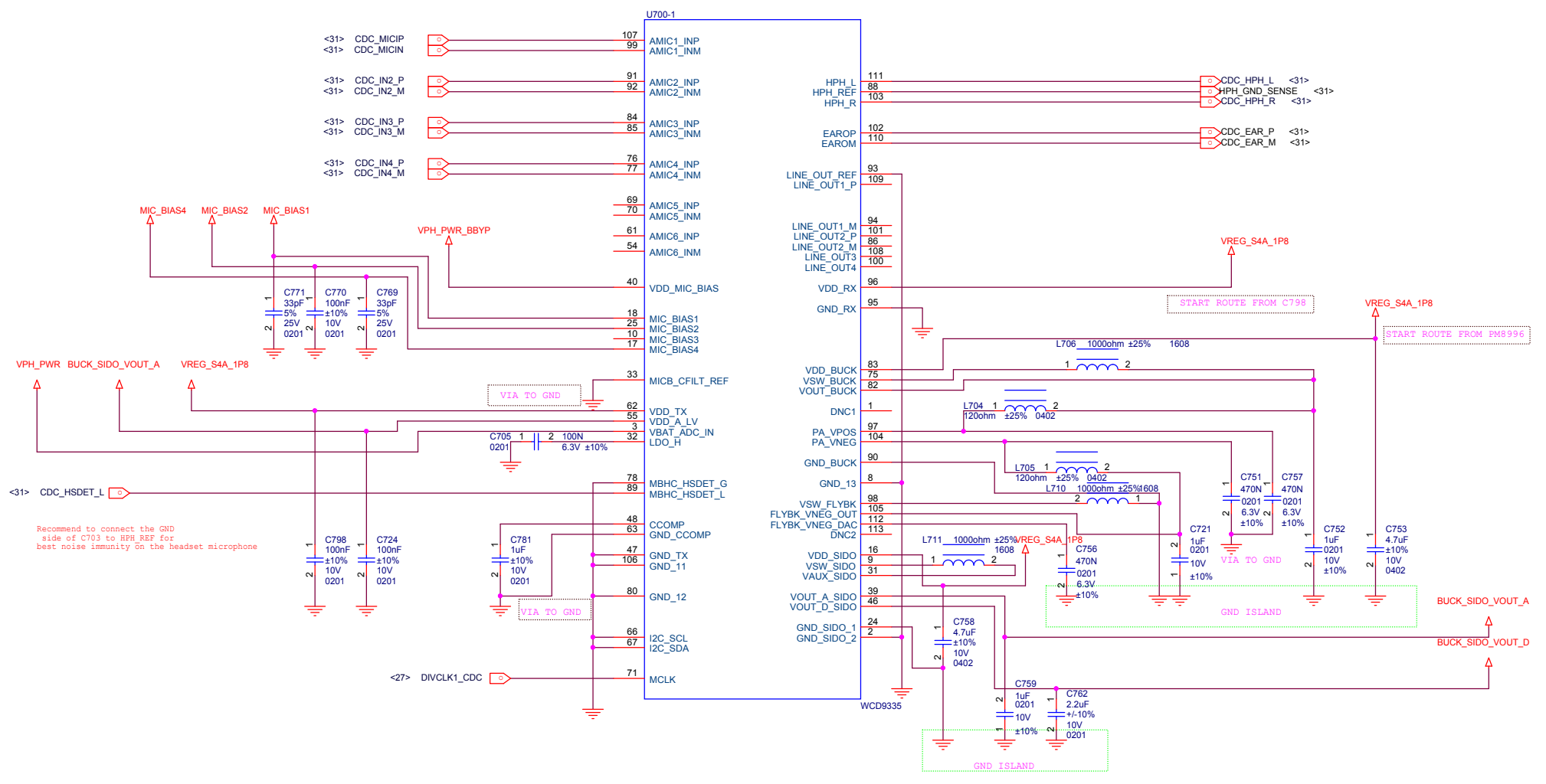

Title			
A1			
Size	Document Number	Rev	
A2	<Doc>	P0	
Date:	Wednesday, December 09, 2015	Sheet	33 of 37

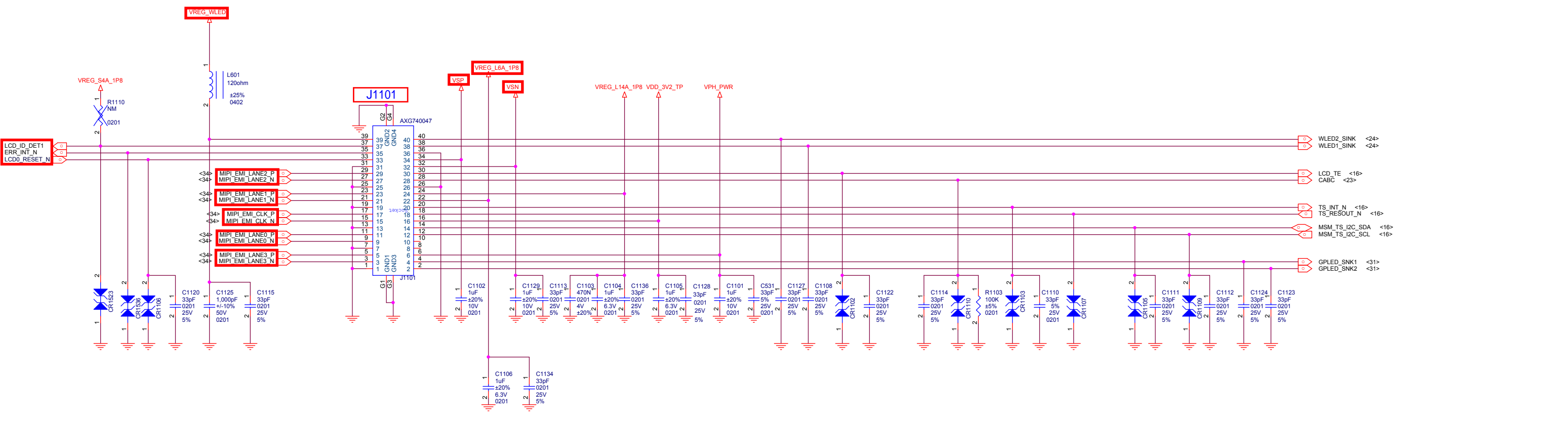
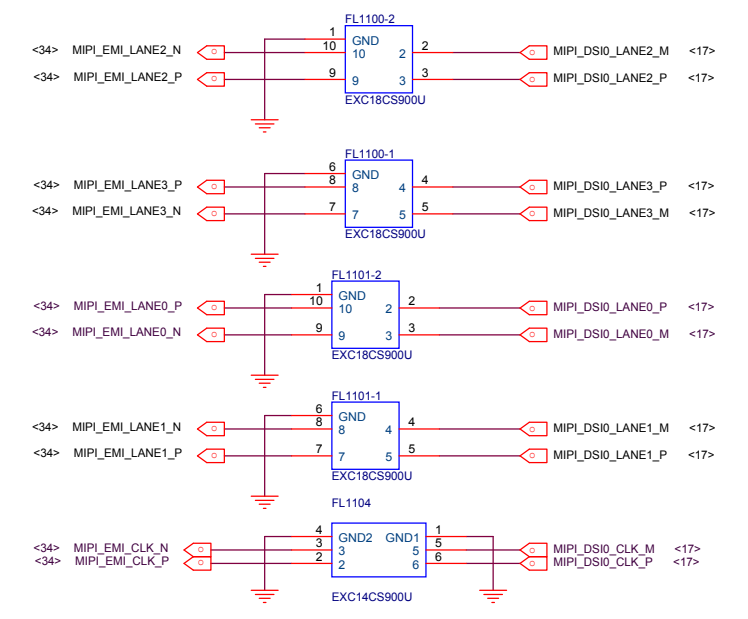
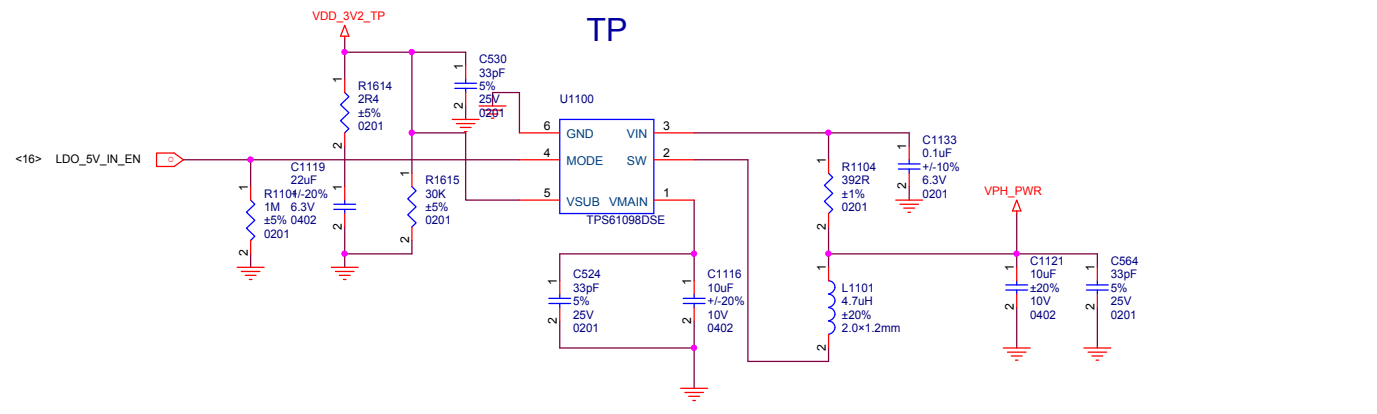

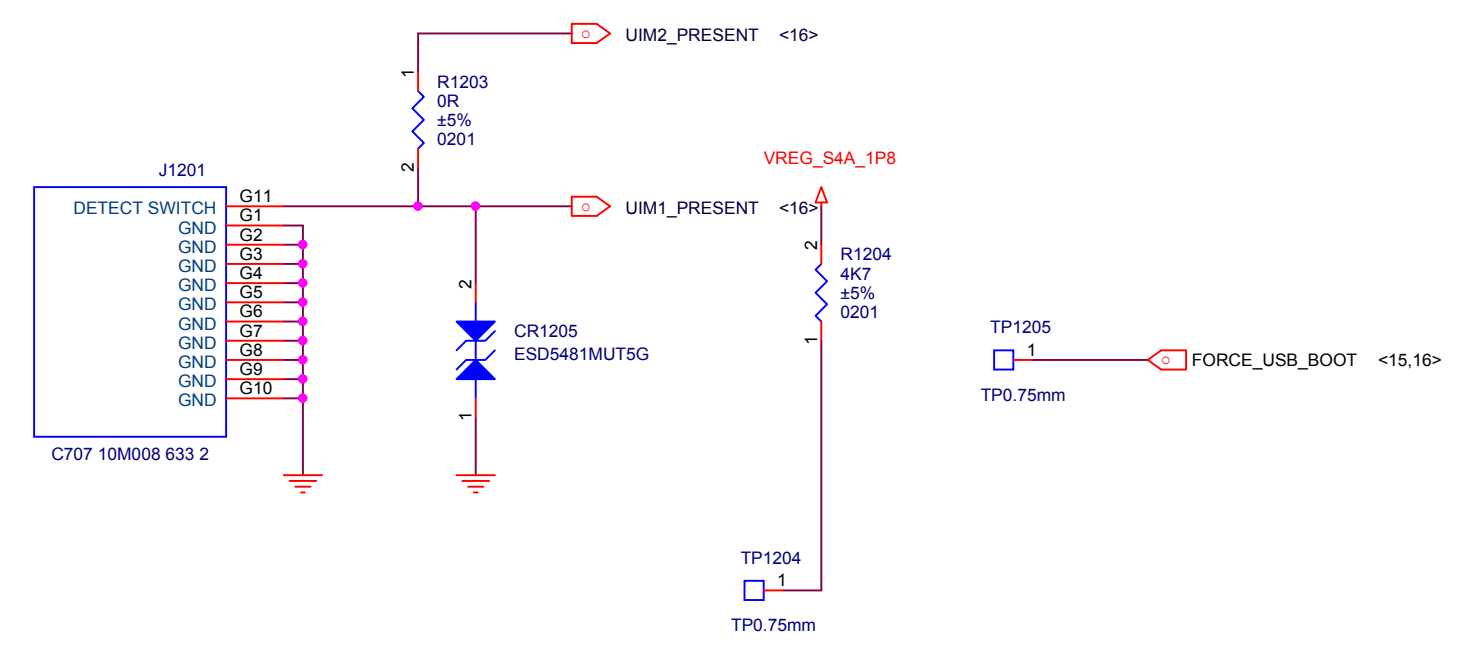
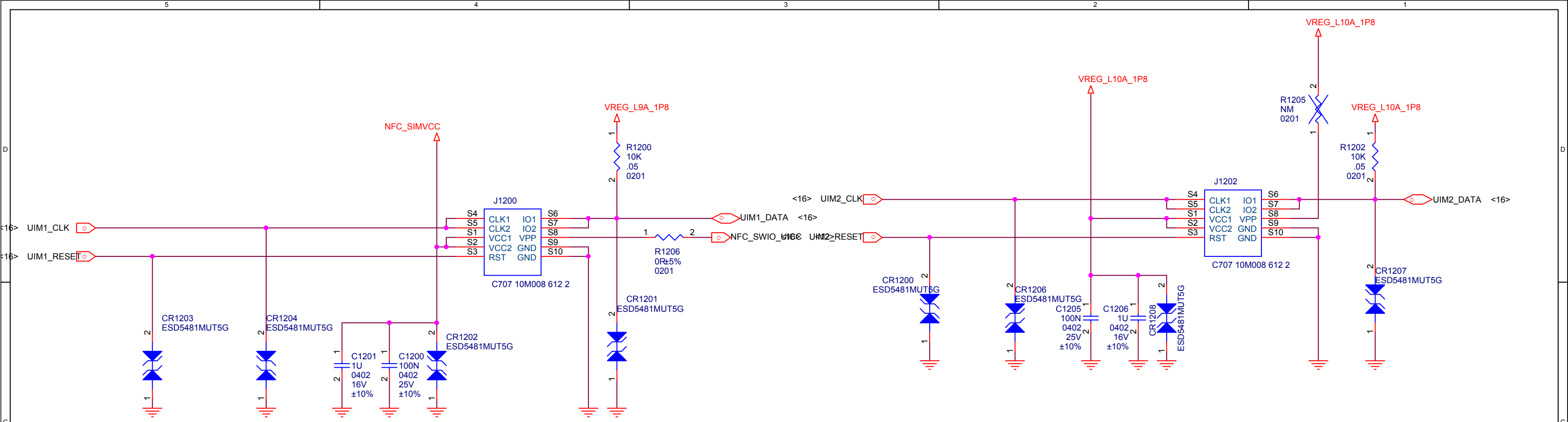

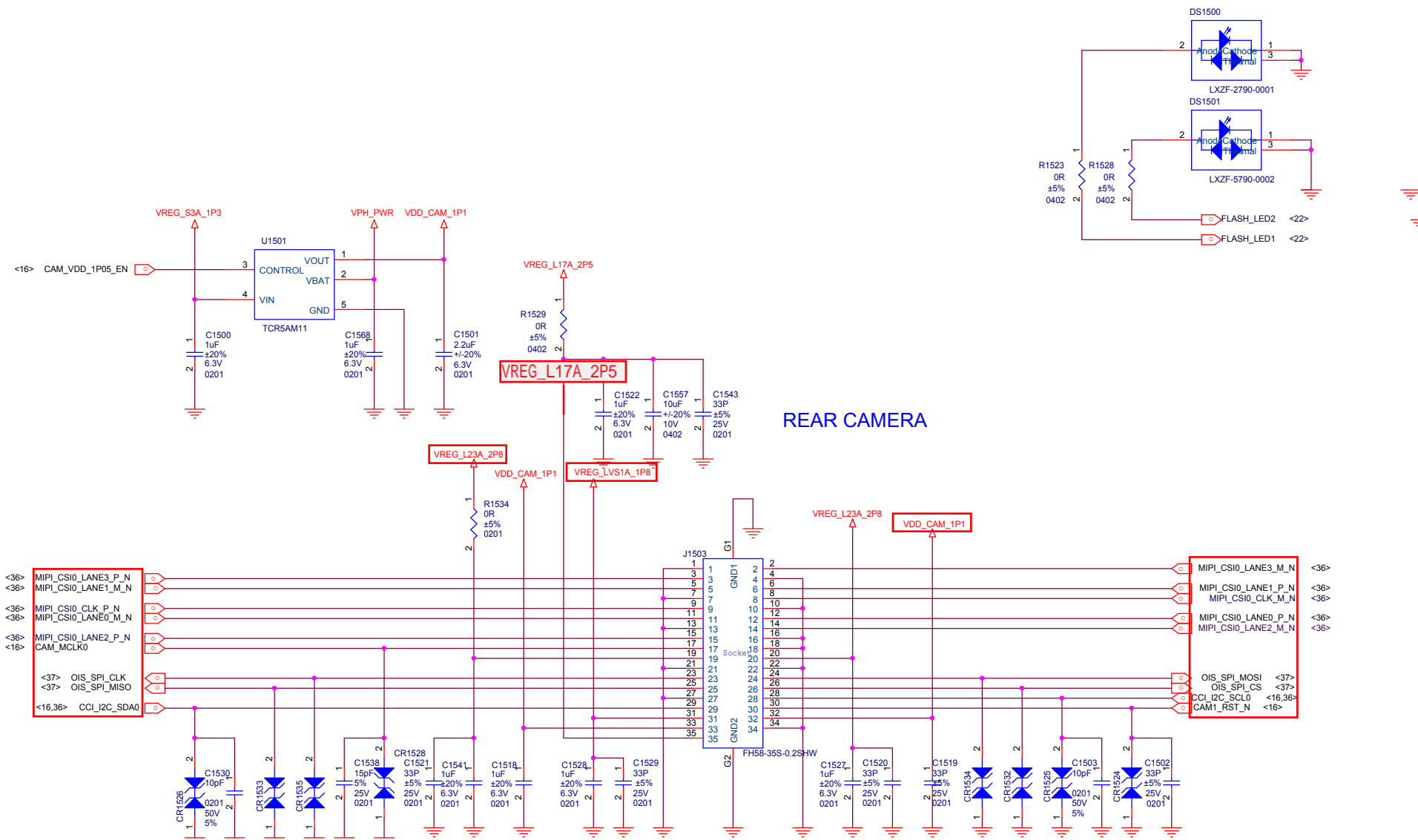

REAR CAMERA

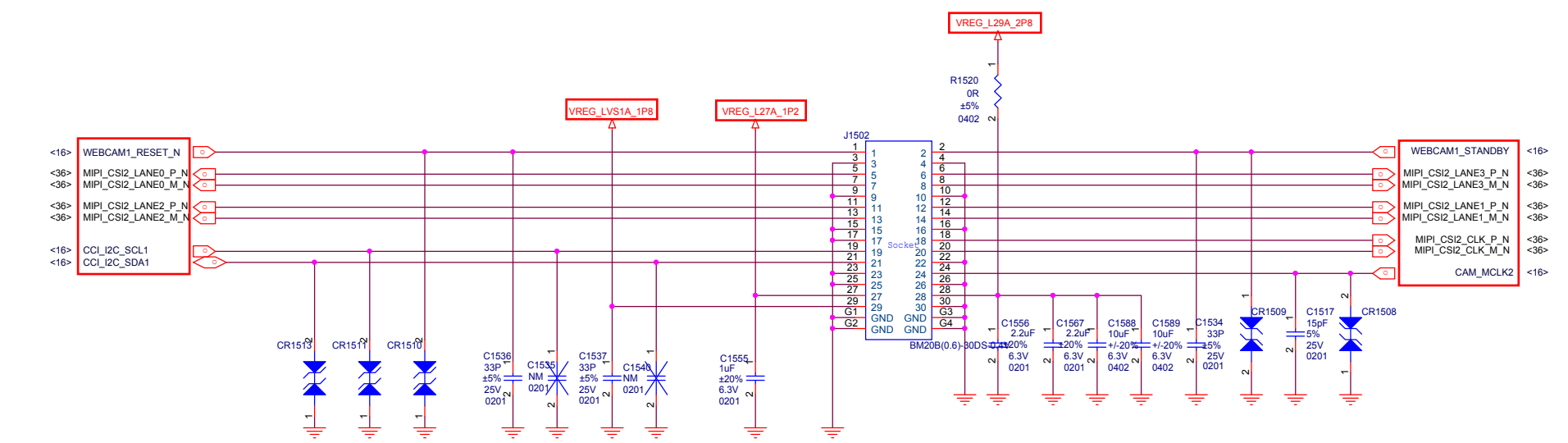

FRONT CAMERA

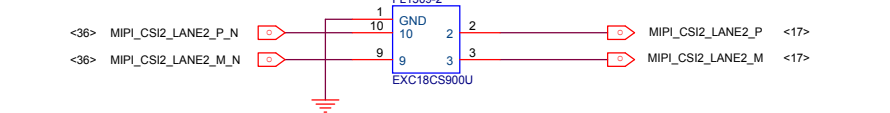
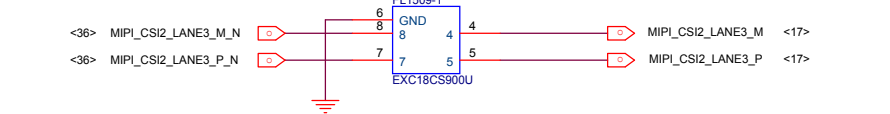
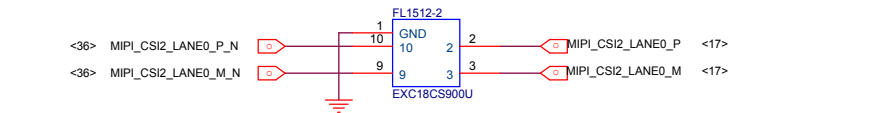
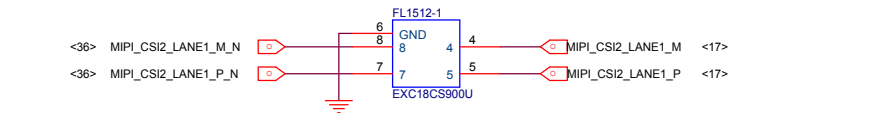
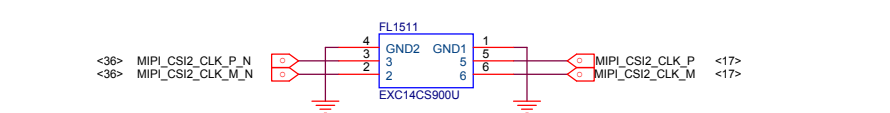
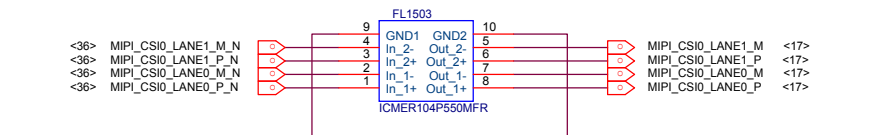
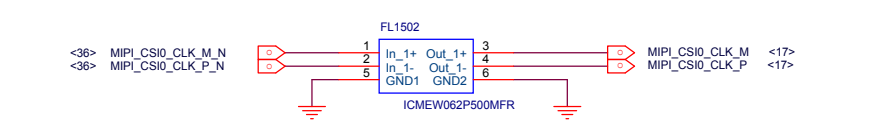
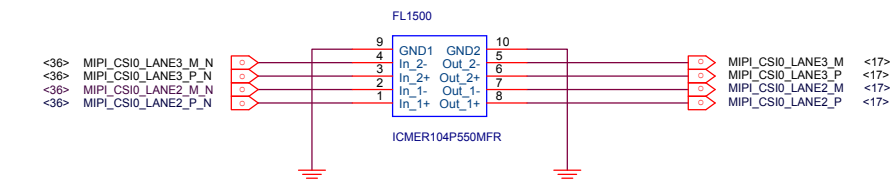

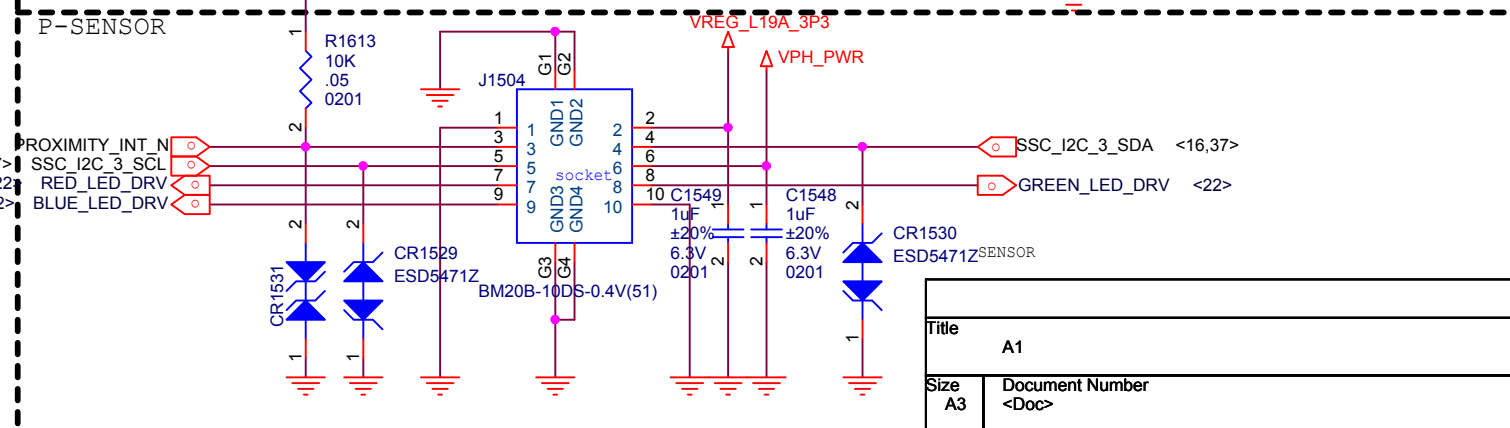
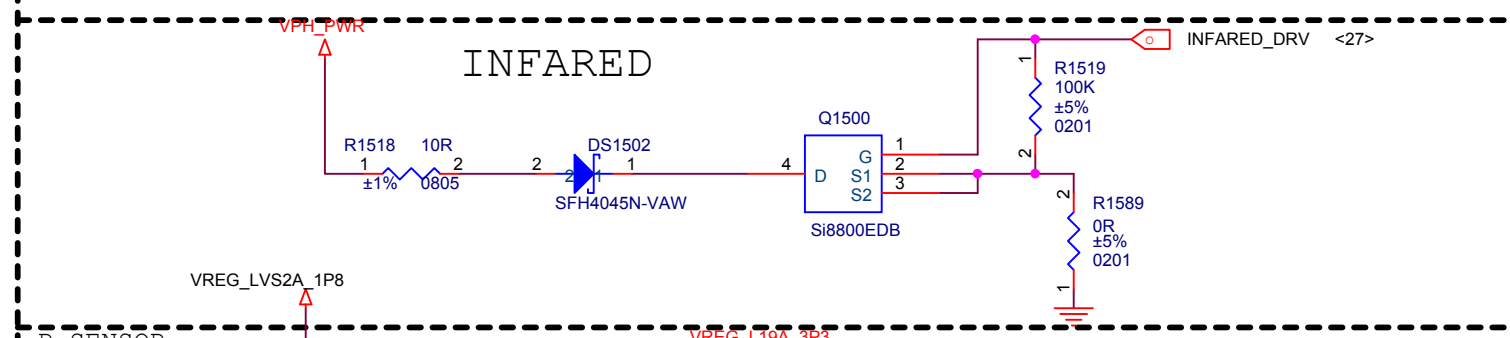
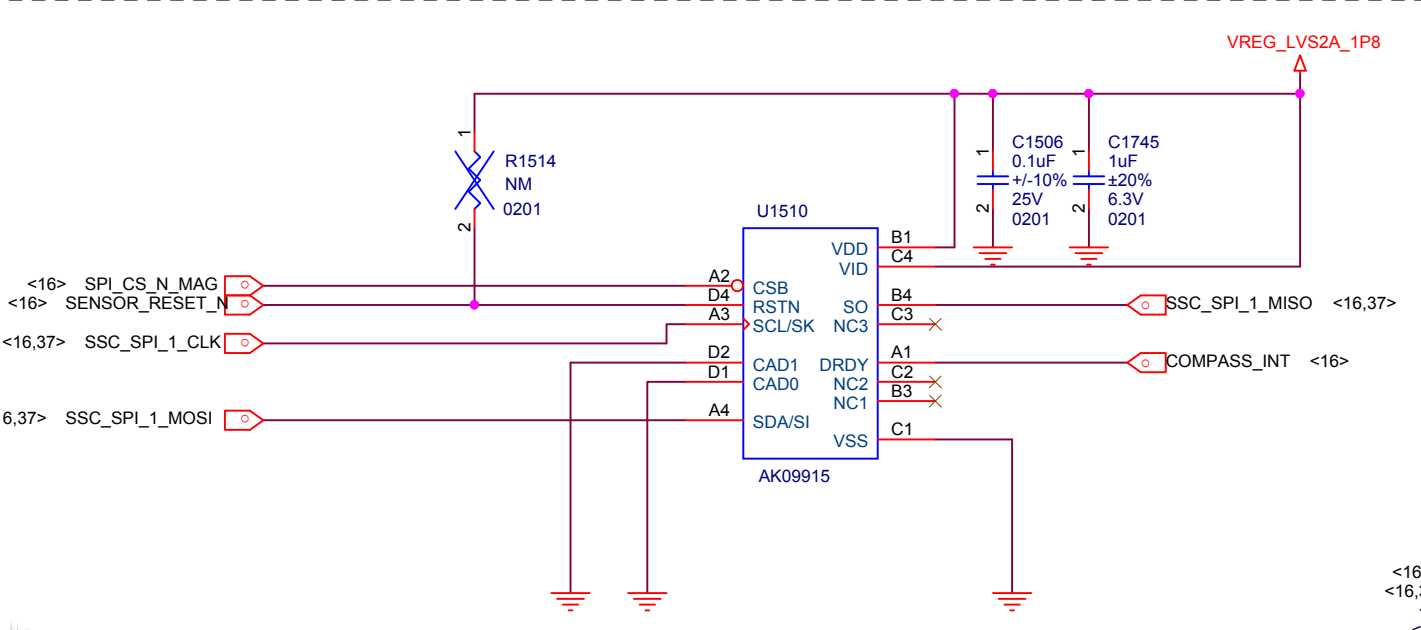
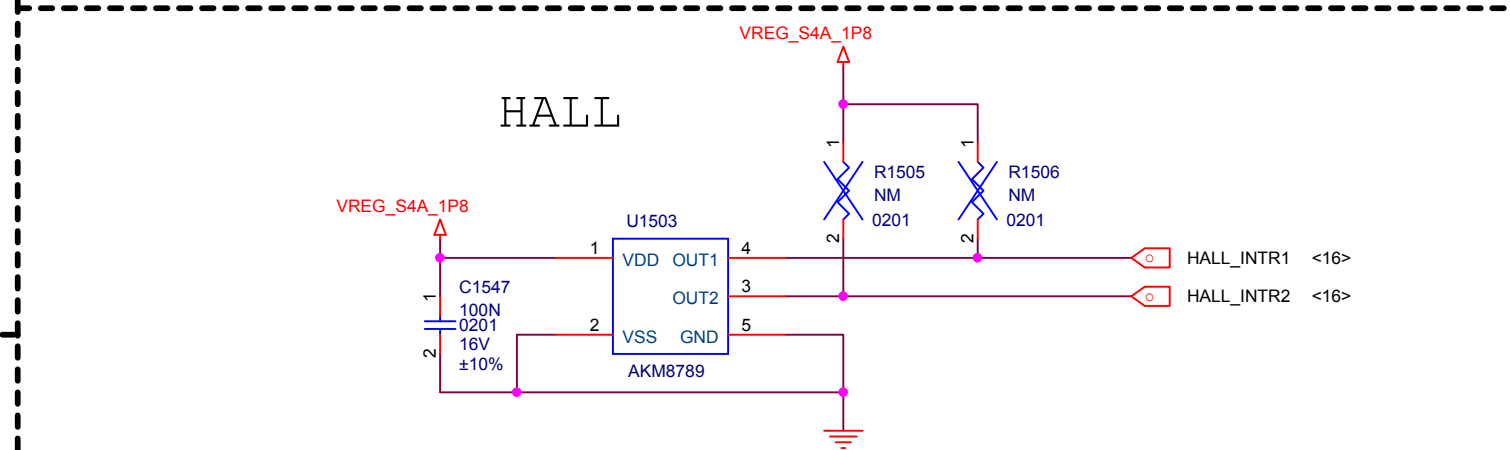
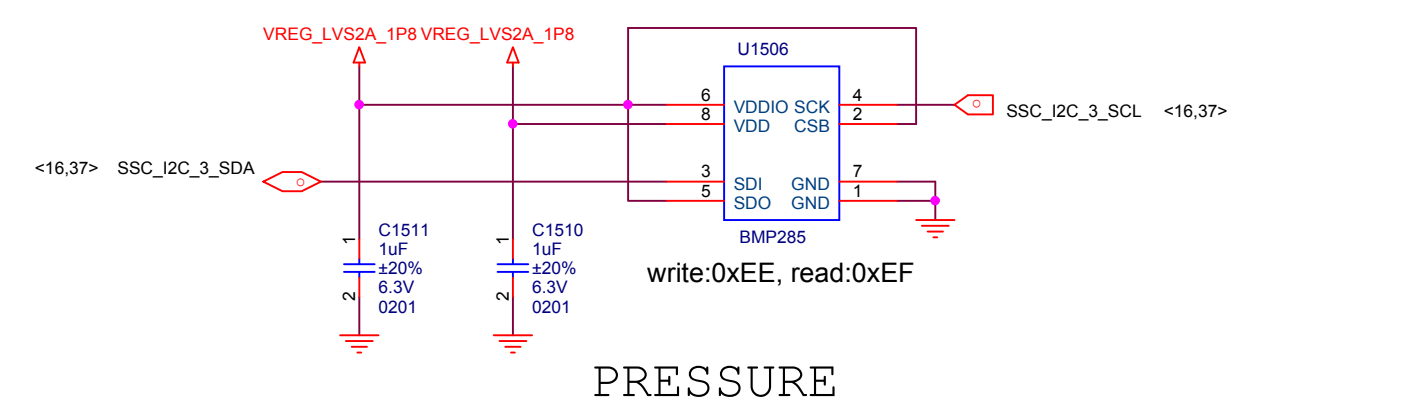
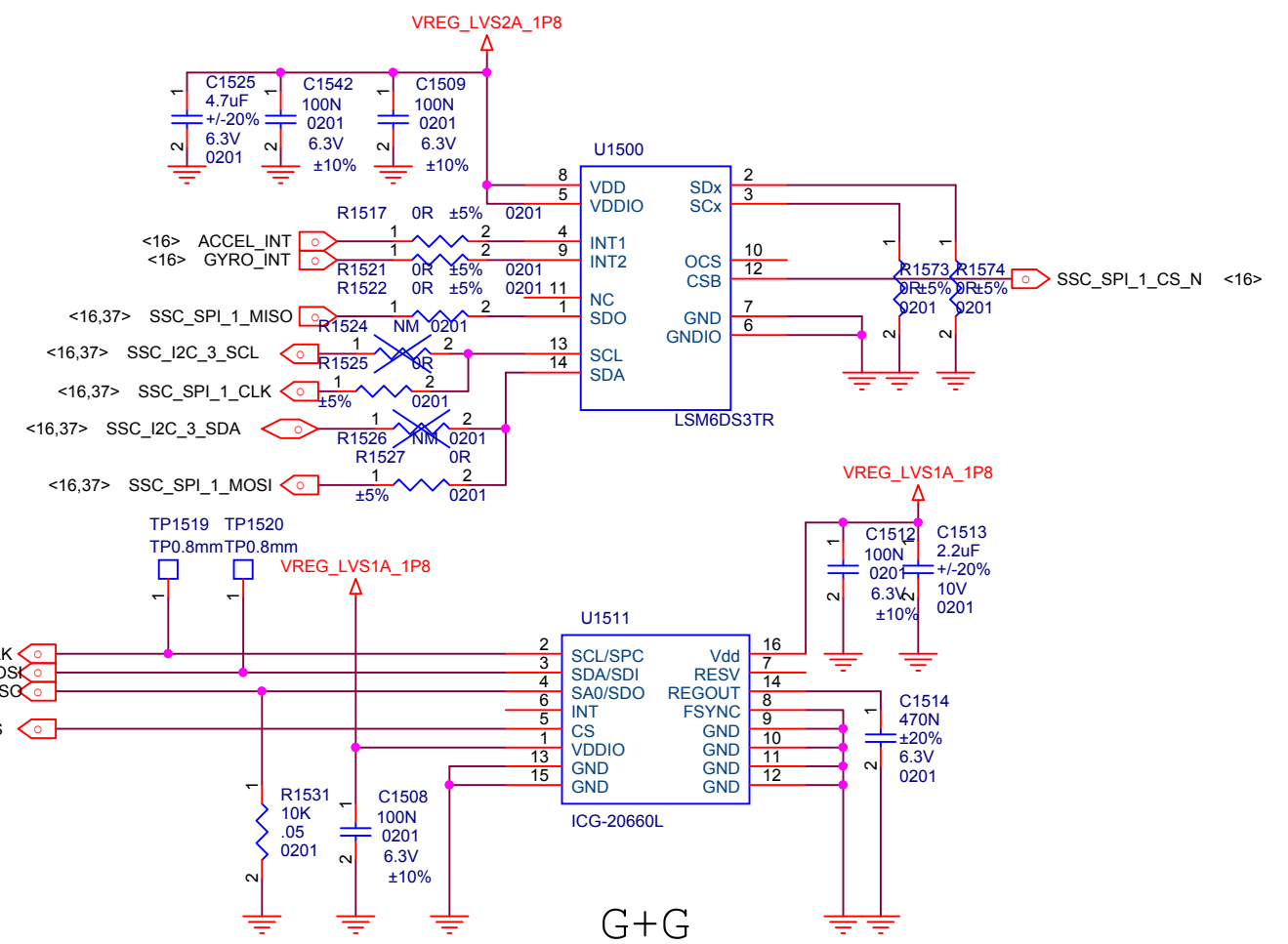
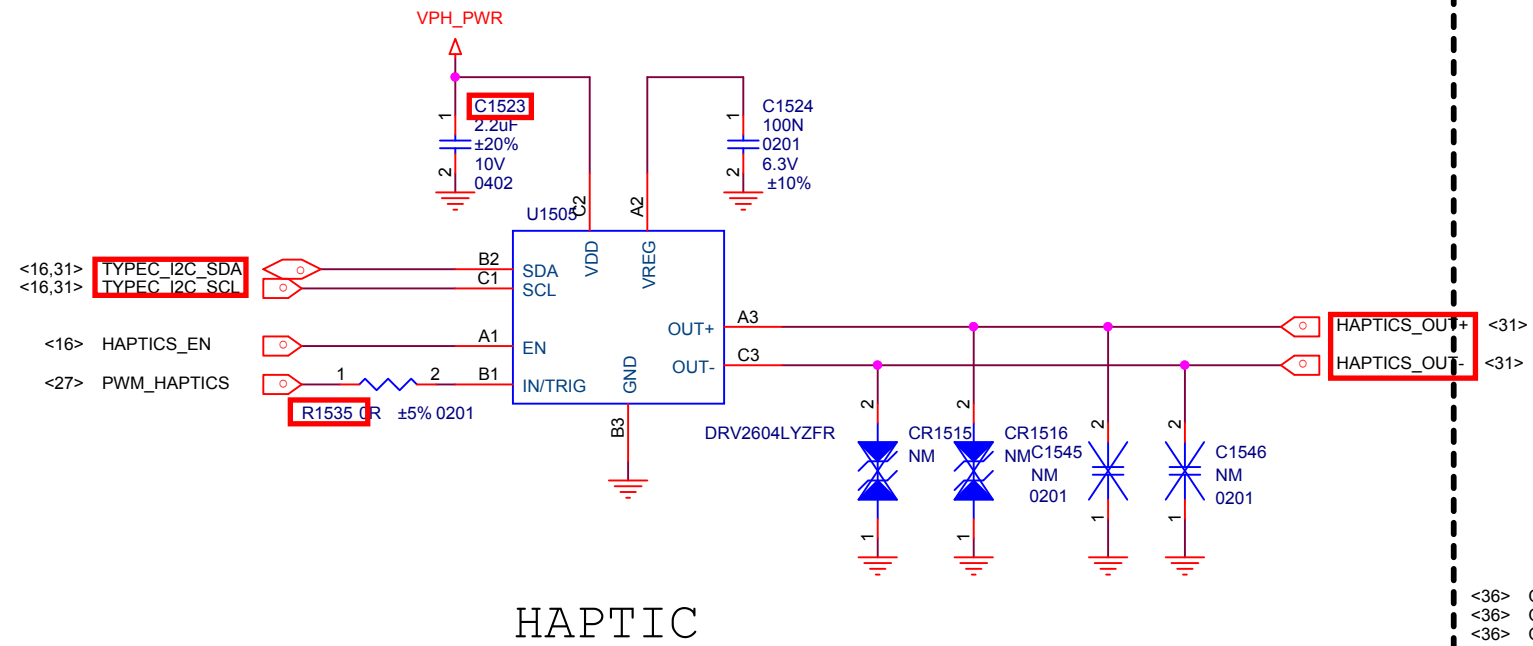

Title		
A1		
Size	Document Number	Rev
A3	<Doc>	P0
Date:	Sheet 37 of 37	