

DRX_ANT

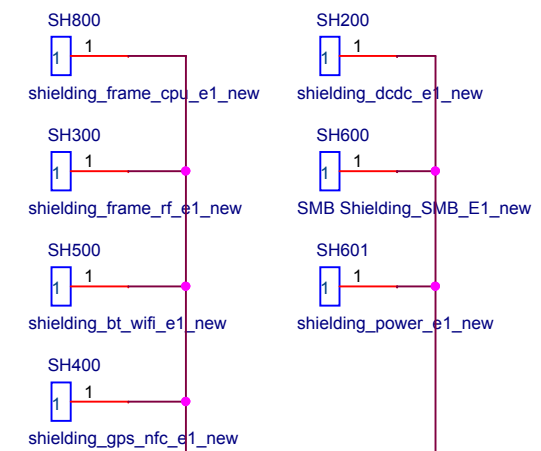

TUNER_CTR

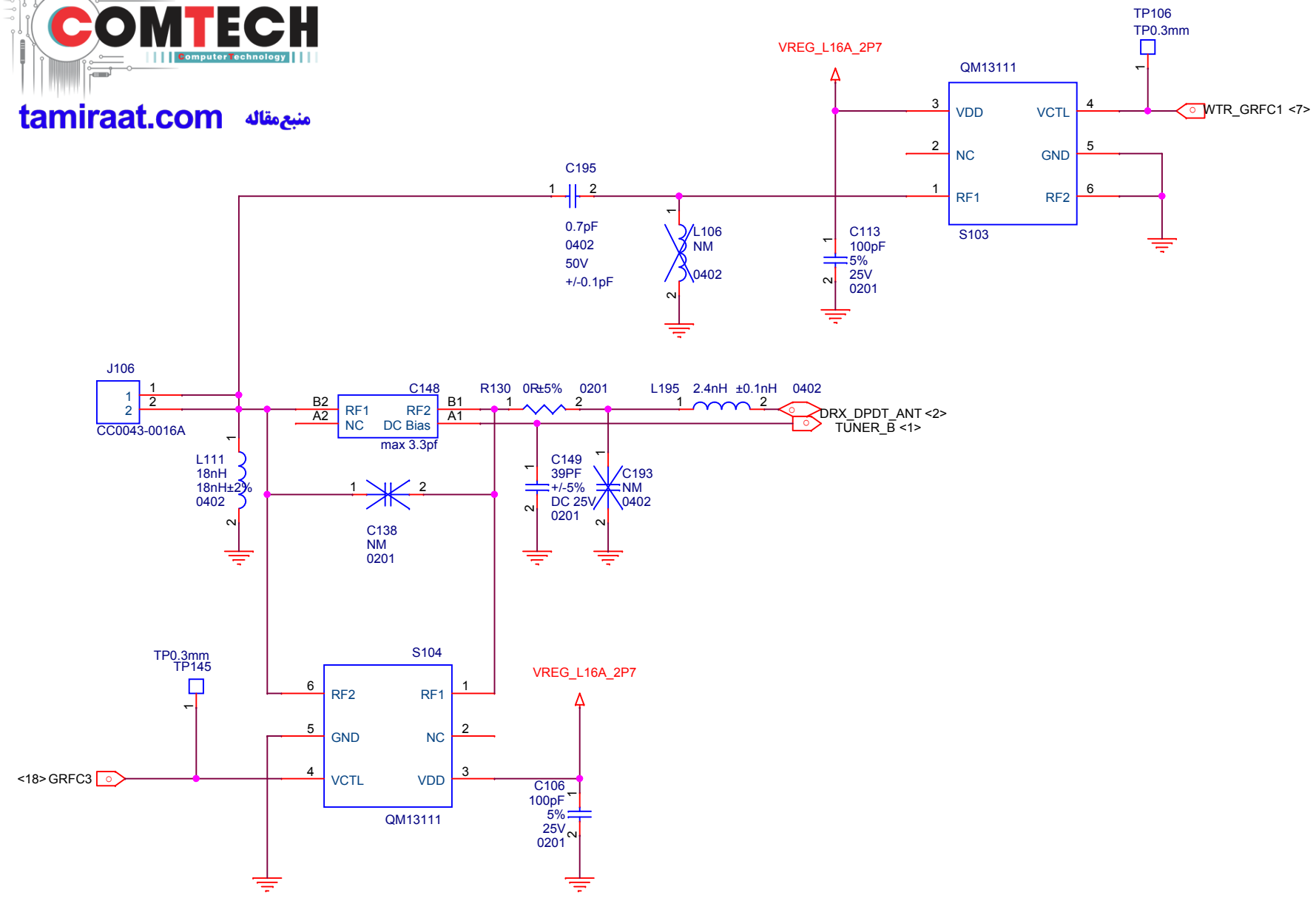
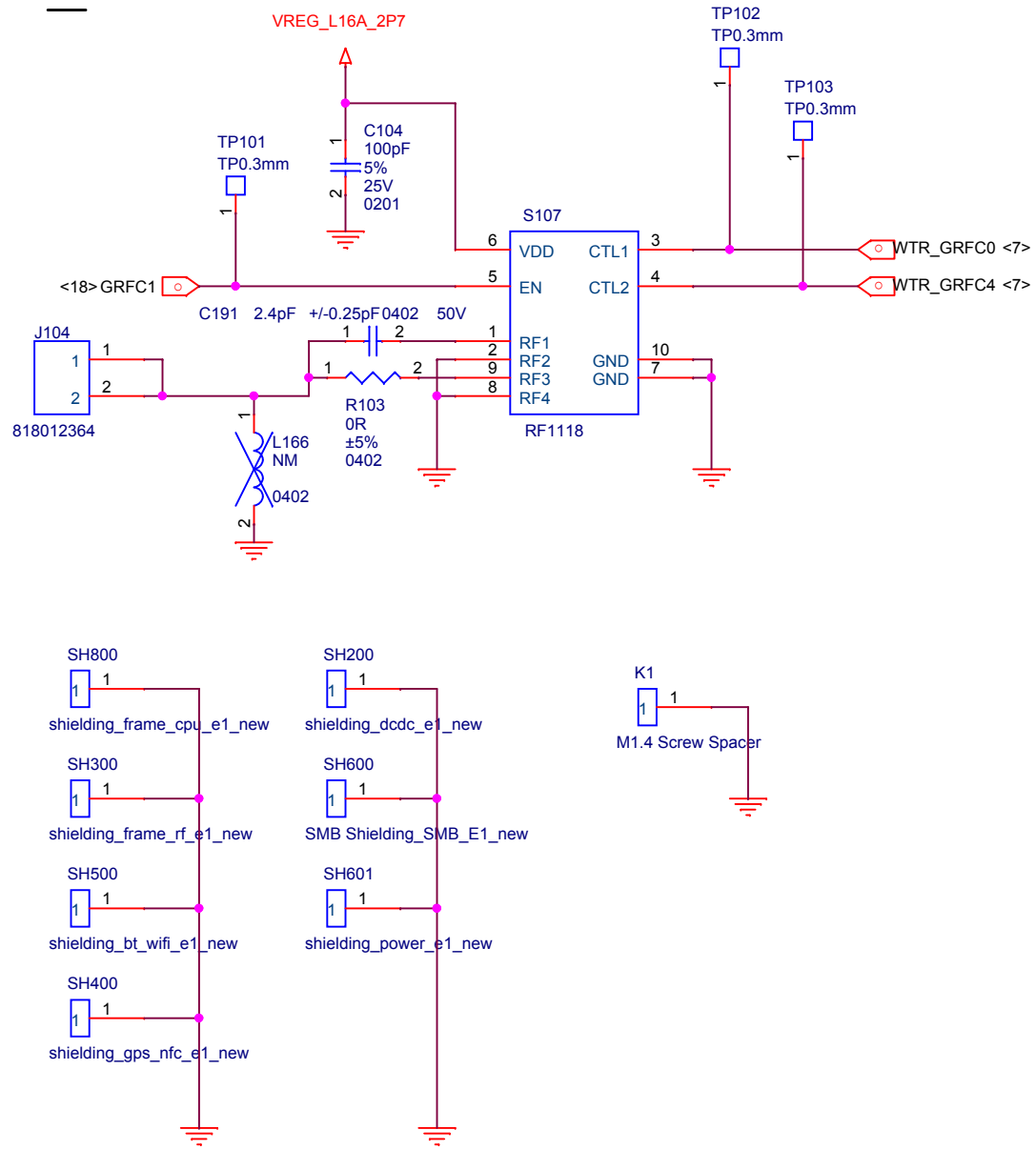
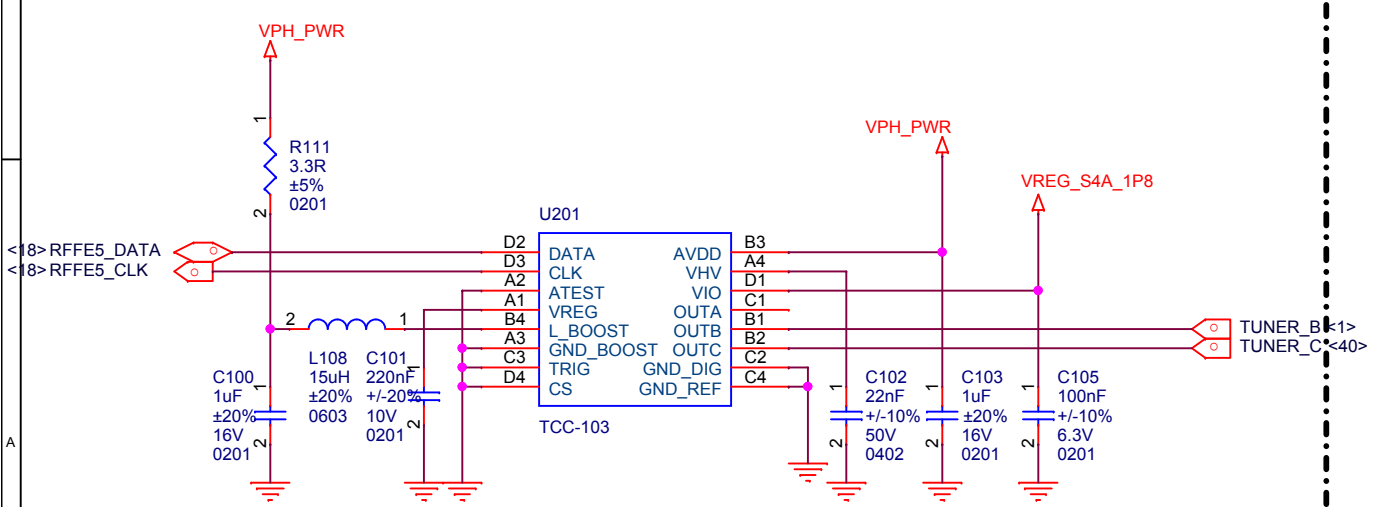

4X4 MIMO ANT3

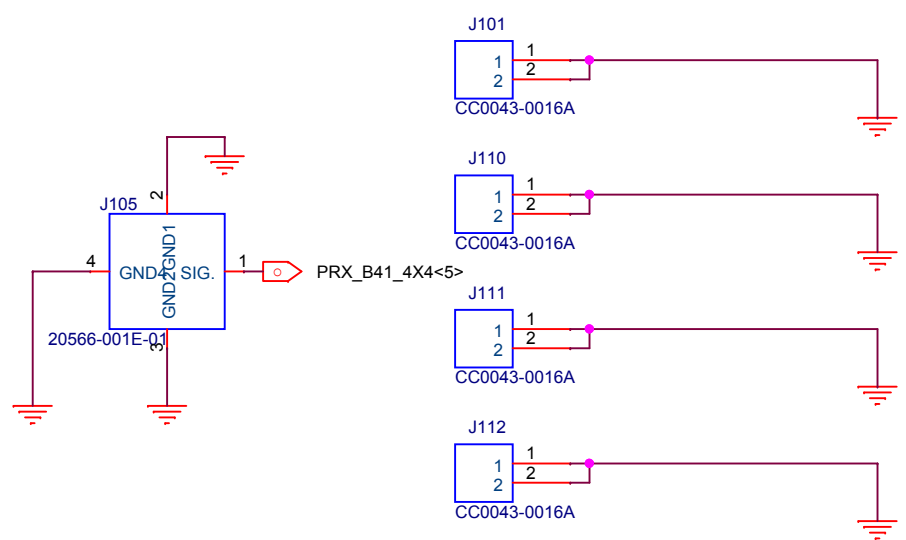

4X4 MIMO ANT4

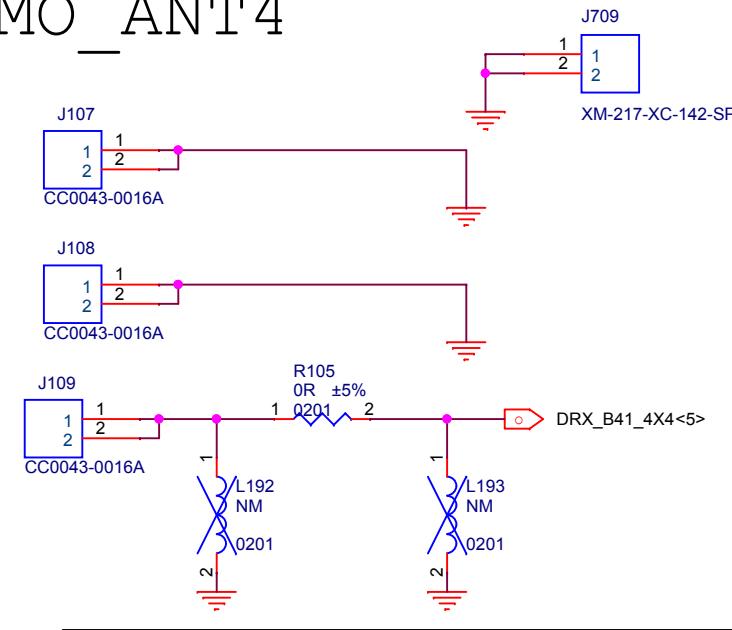

Title		E8	
Size	Document Number	ANT	
Date:	Monday, April 02, 2018	Sheet	1 of 44

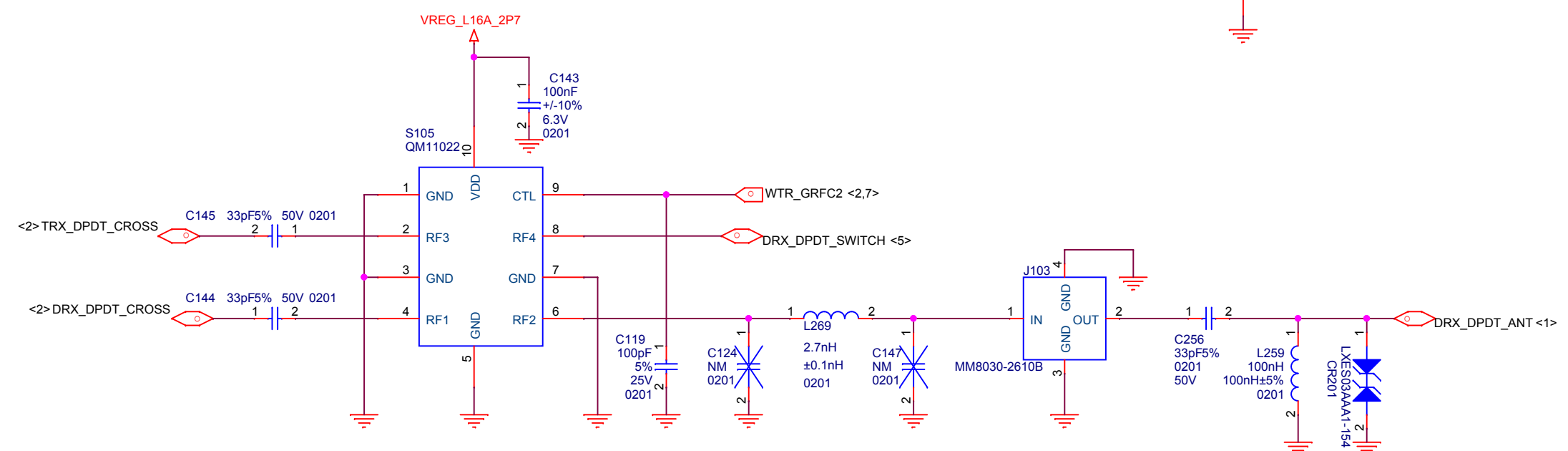
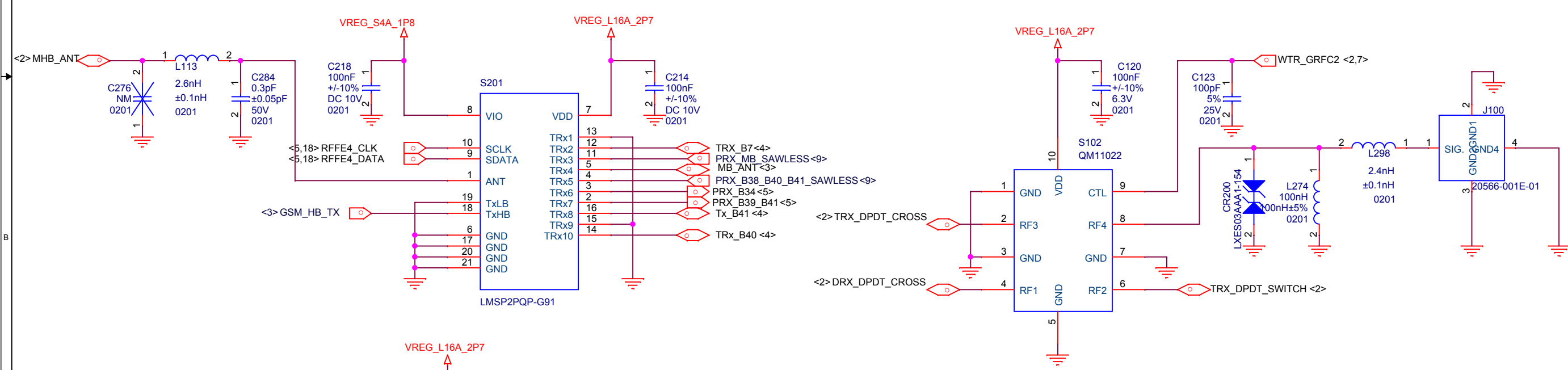
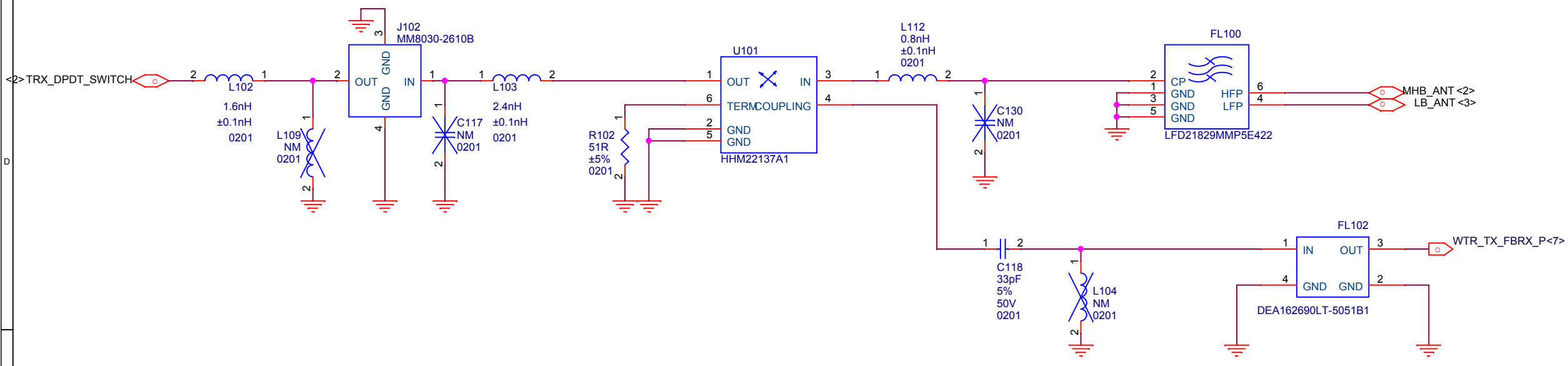

2GPA

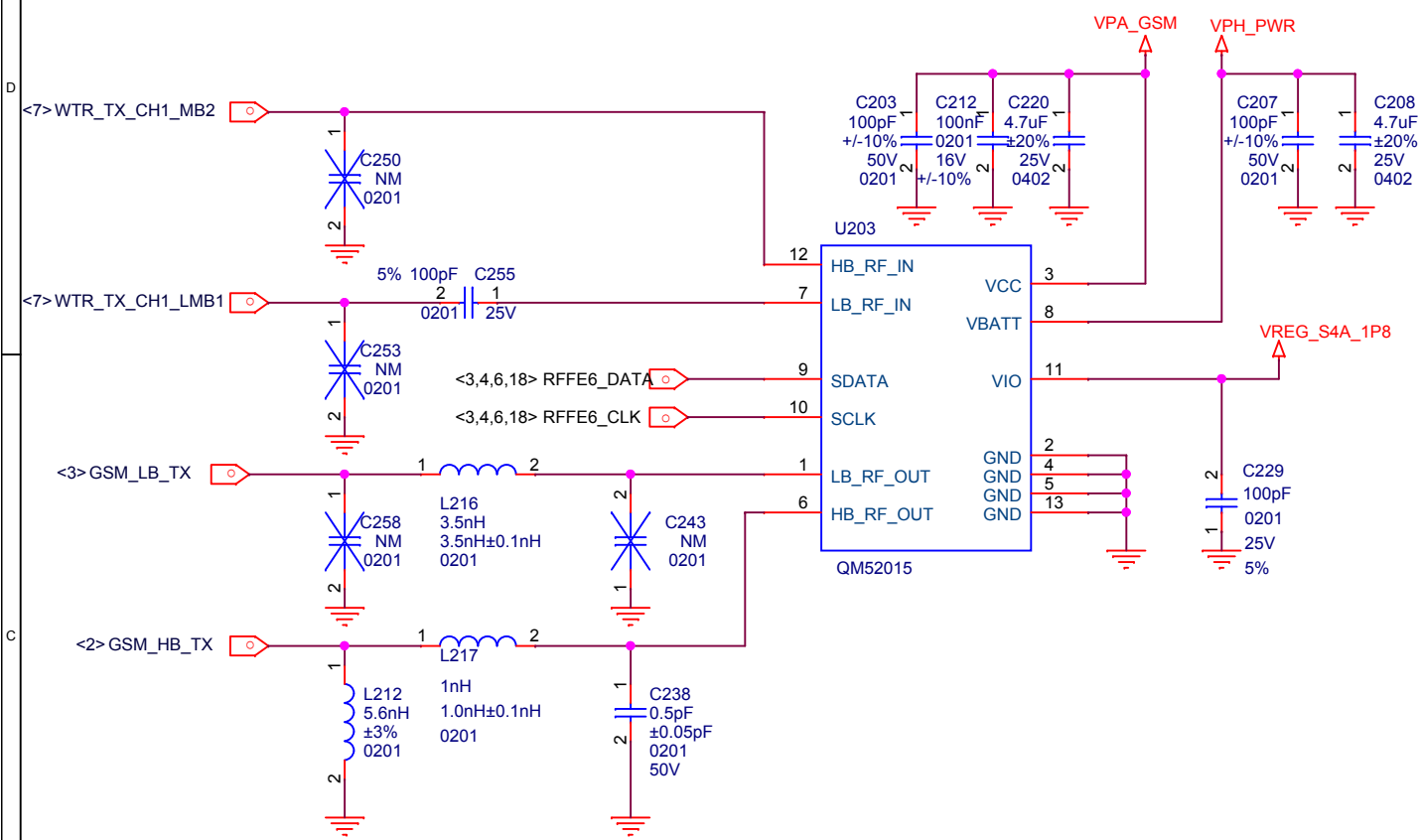

LBPA

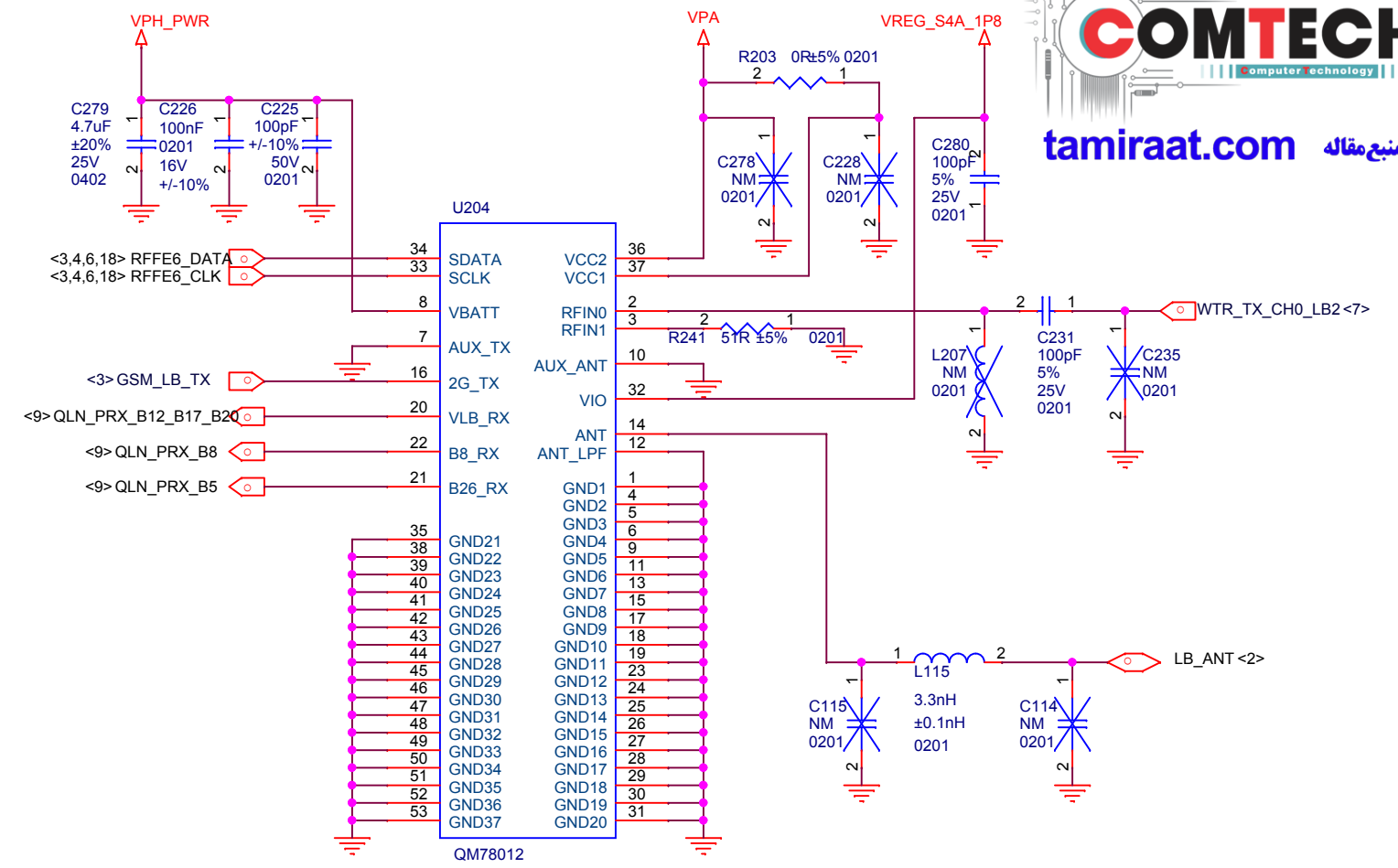

MBPA

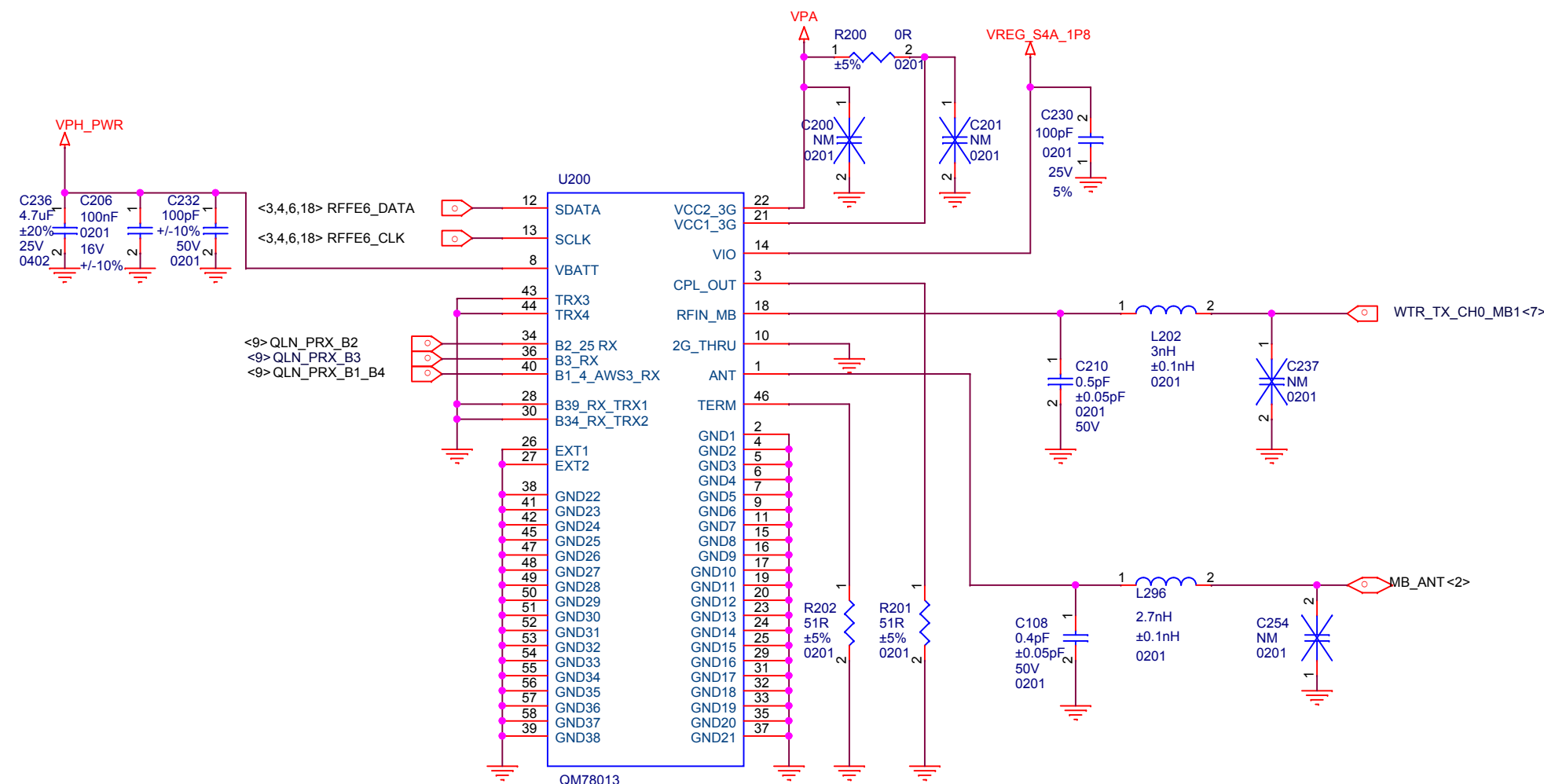

Title		E8	Rev P0
Size	Document Number		
A3	2G&LB&MB PA		
Date:	Friday, March 23, 2018	Sheet 3 of 44	

HBPA

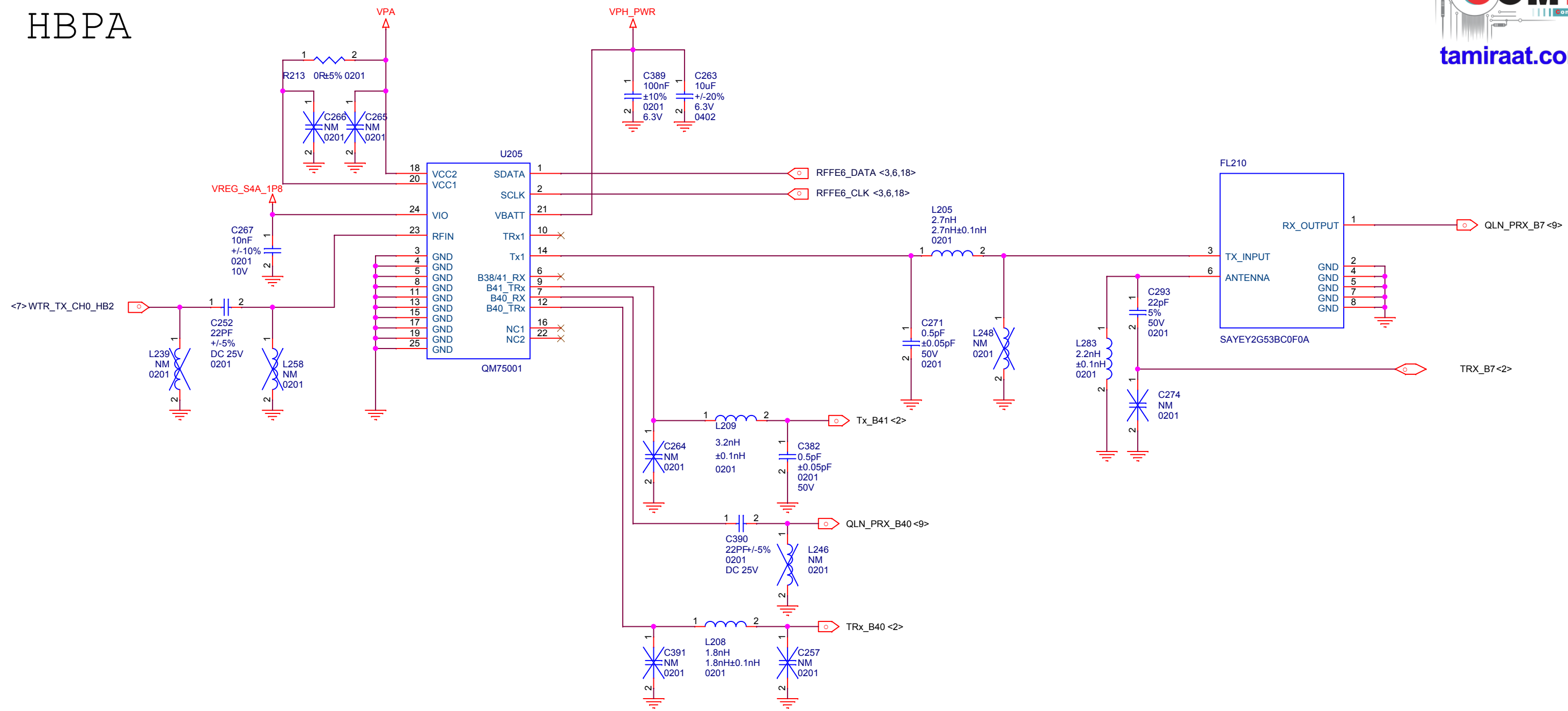

PA THERM

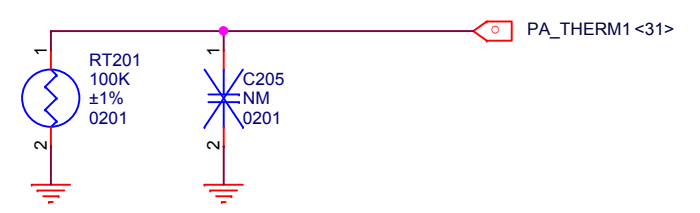

Title		E1	
Size	Document Number	Rev	
A3	HBPA & PA THERM	P0	
Date:	Friday, March 23, 2018	Sheet	4 of 44

PRX B34 B39 B41

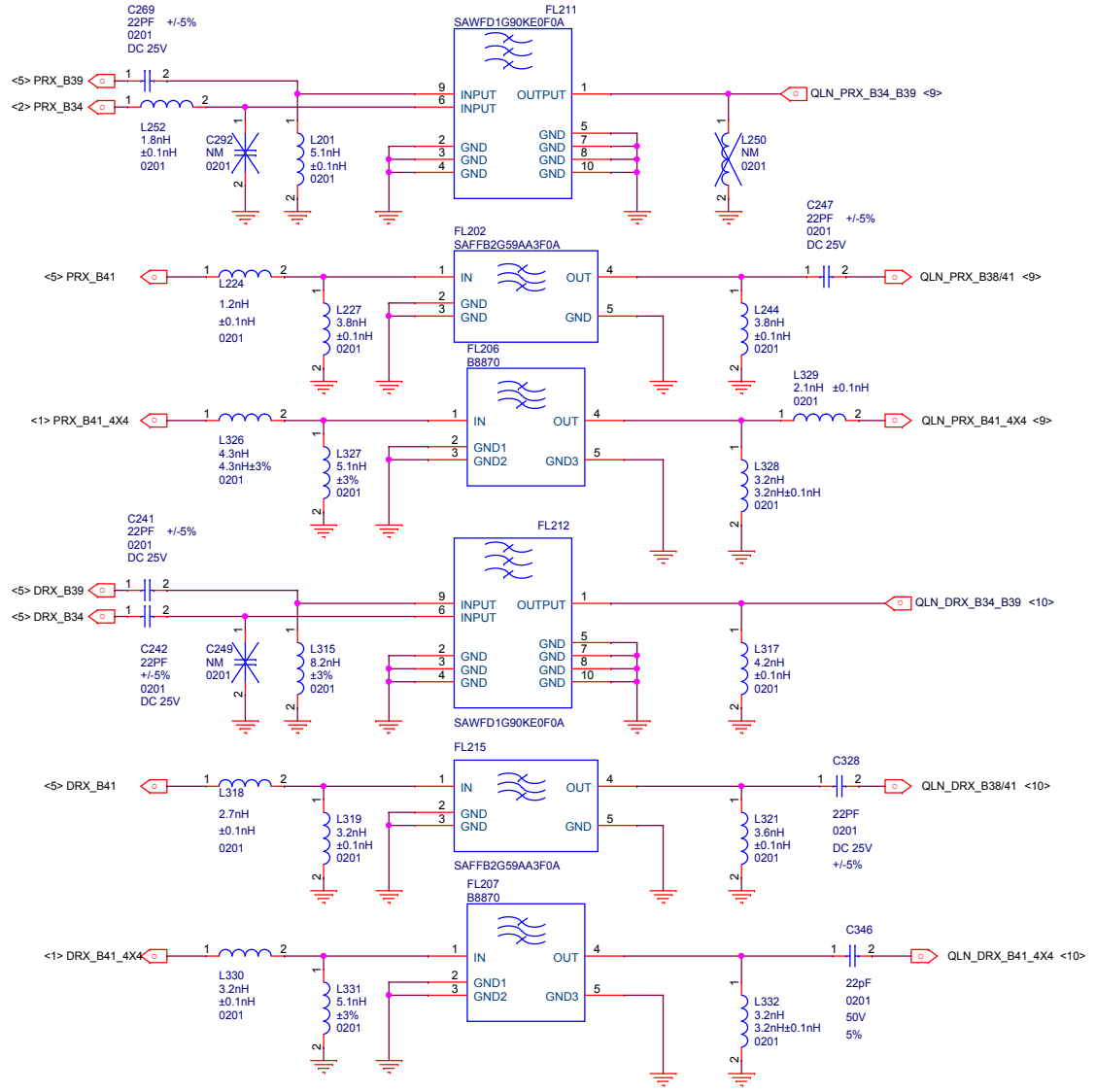

DIPLEXER B39 B41

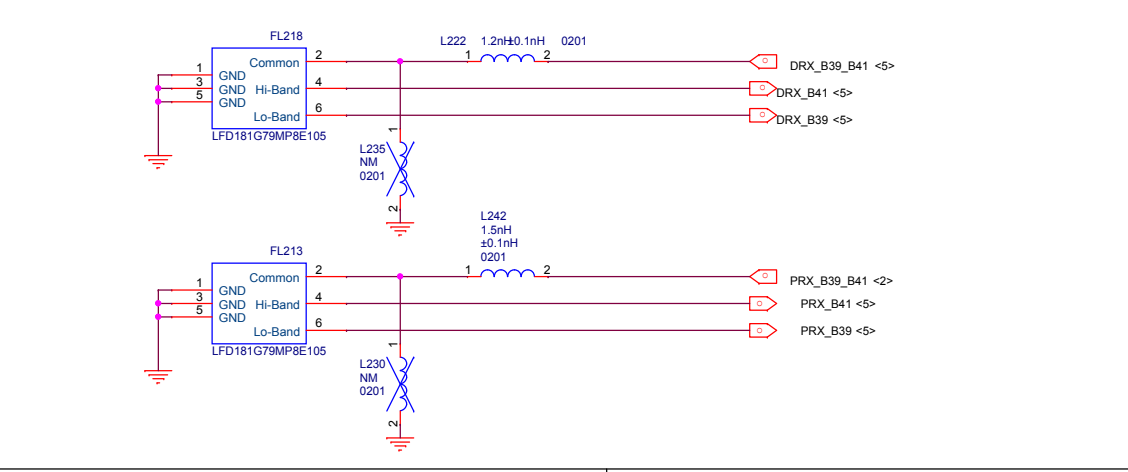

DRX

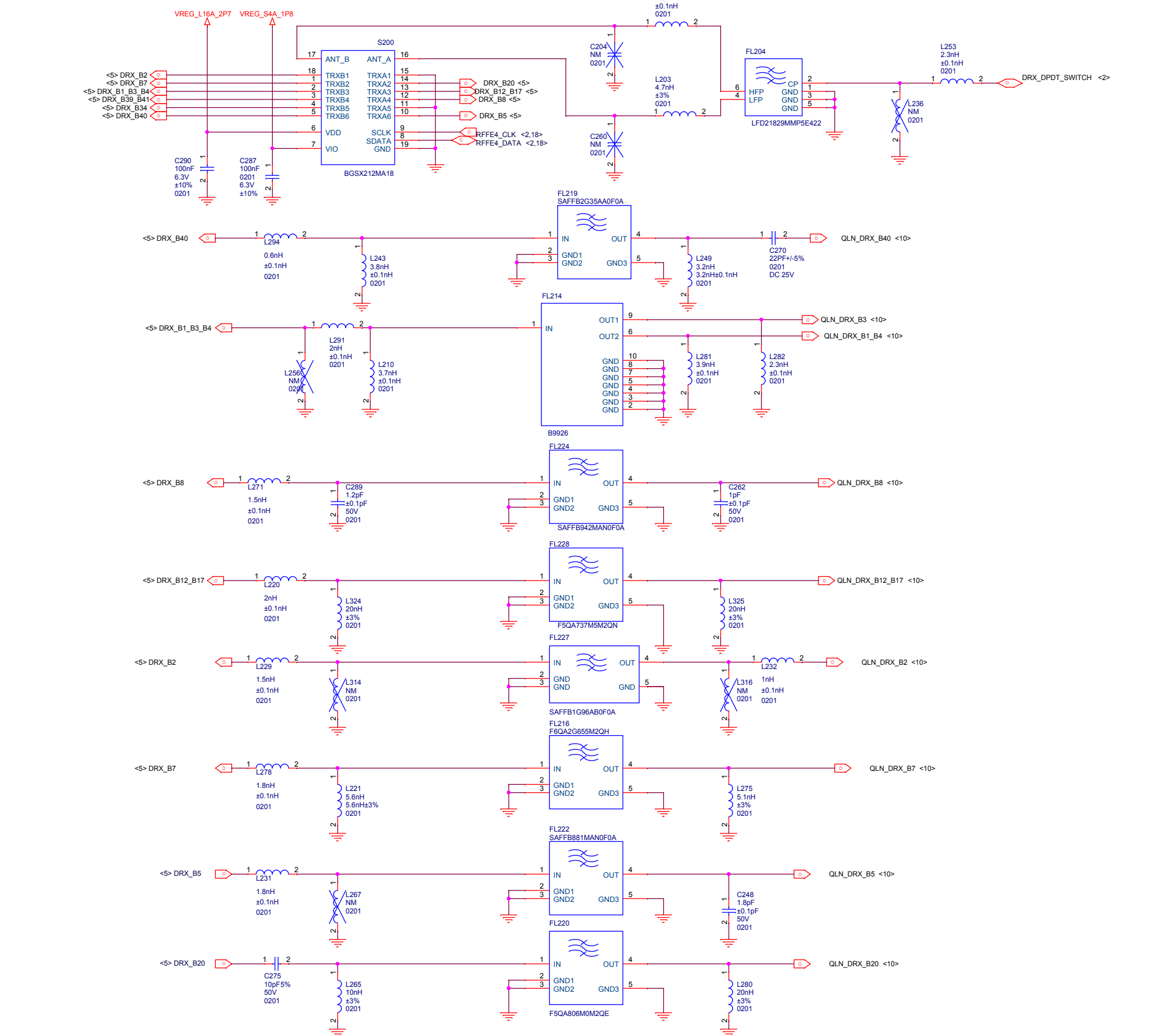

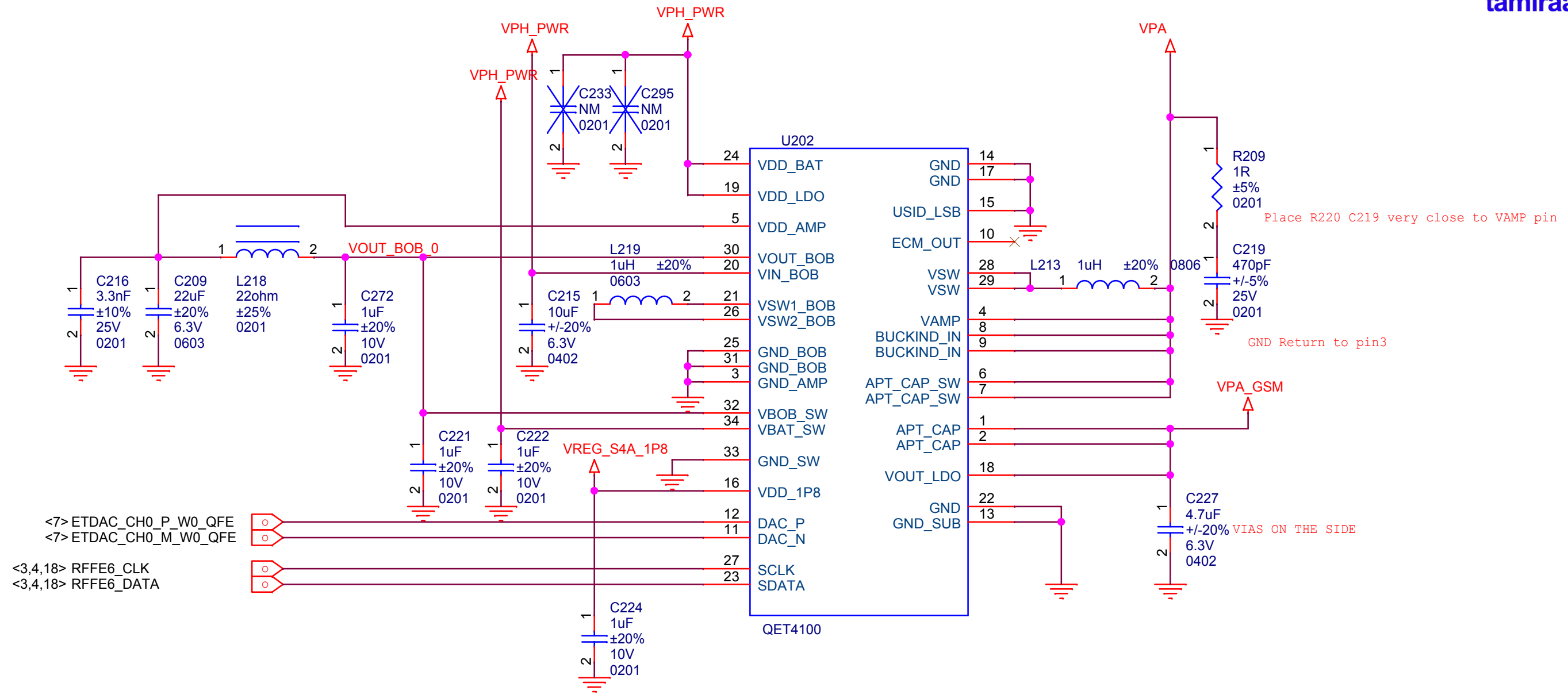

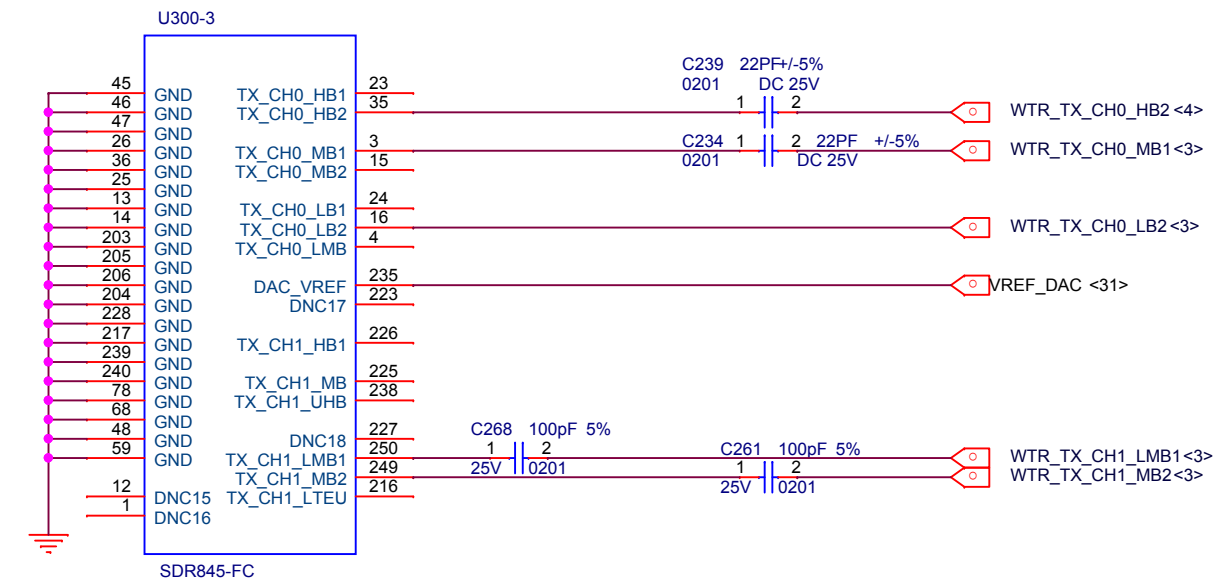
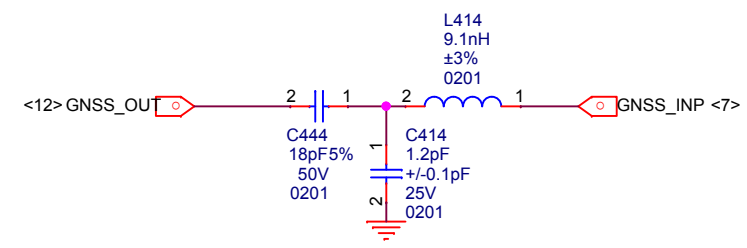
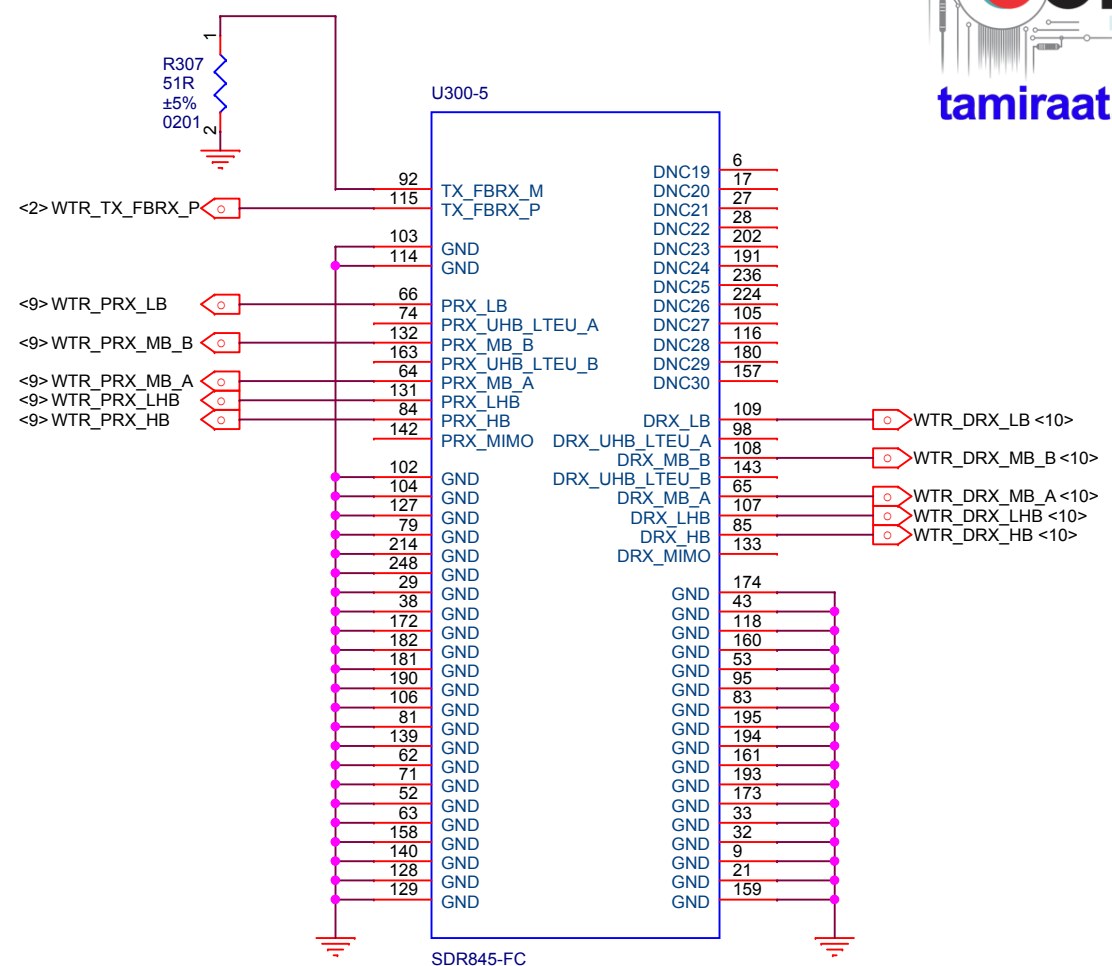
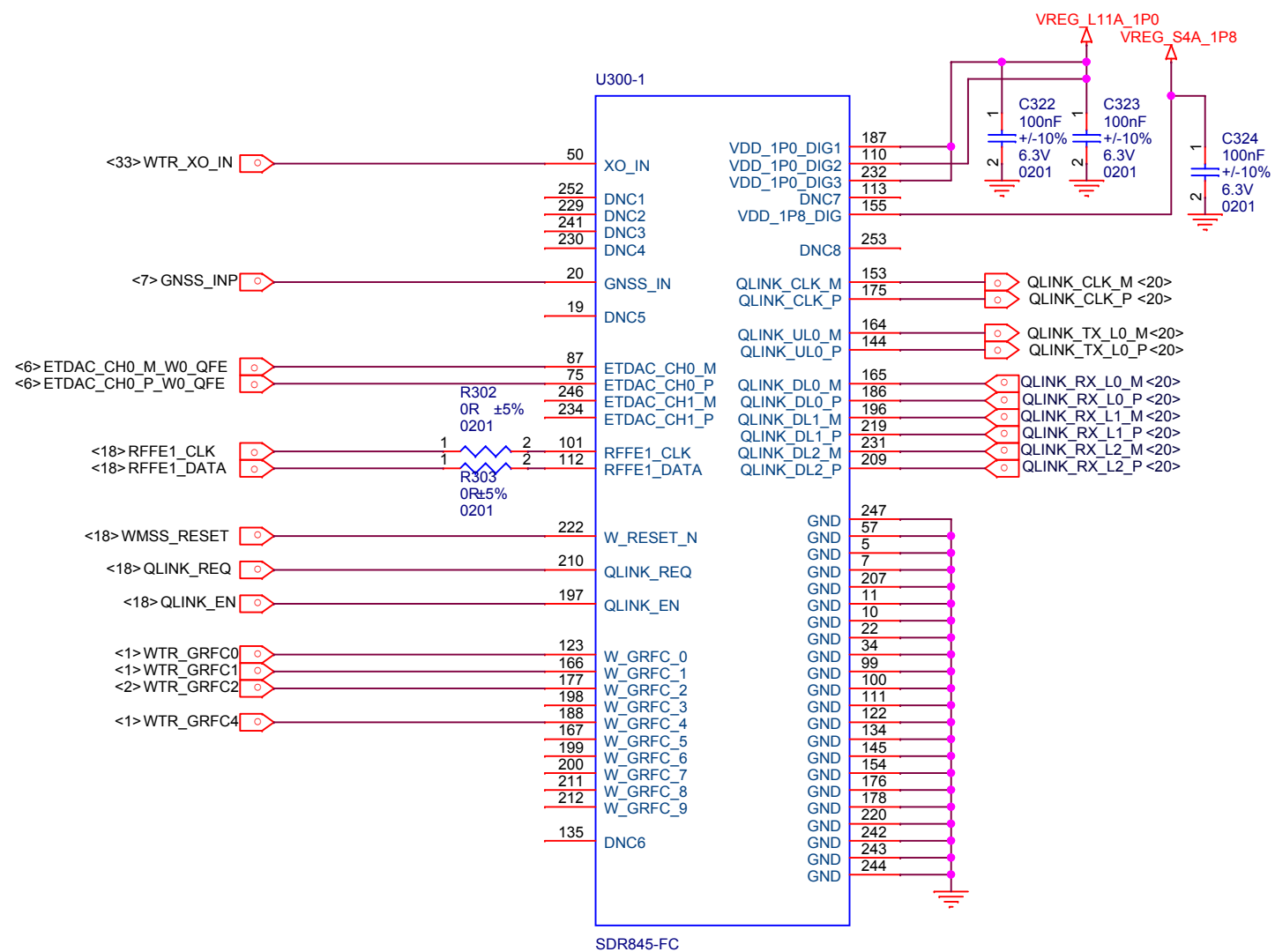

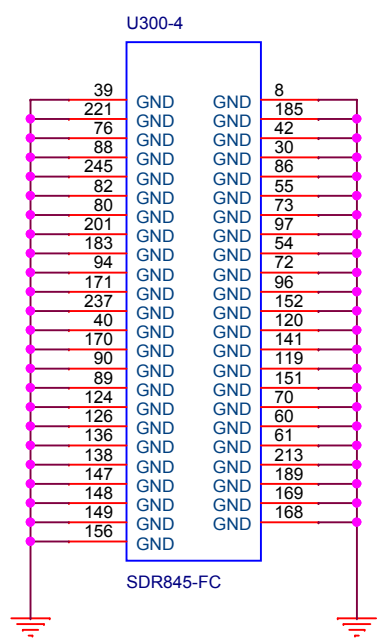
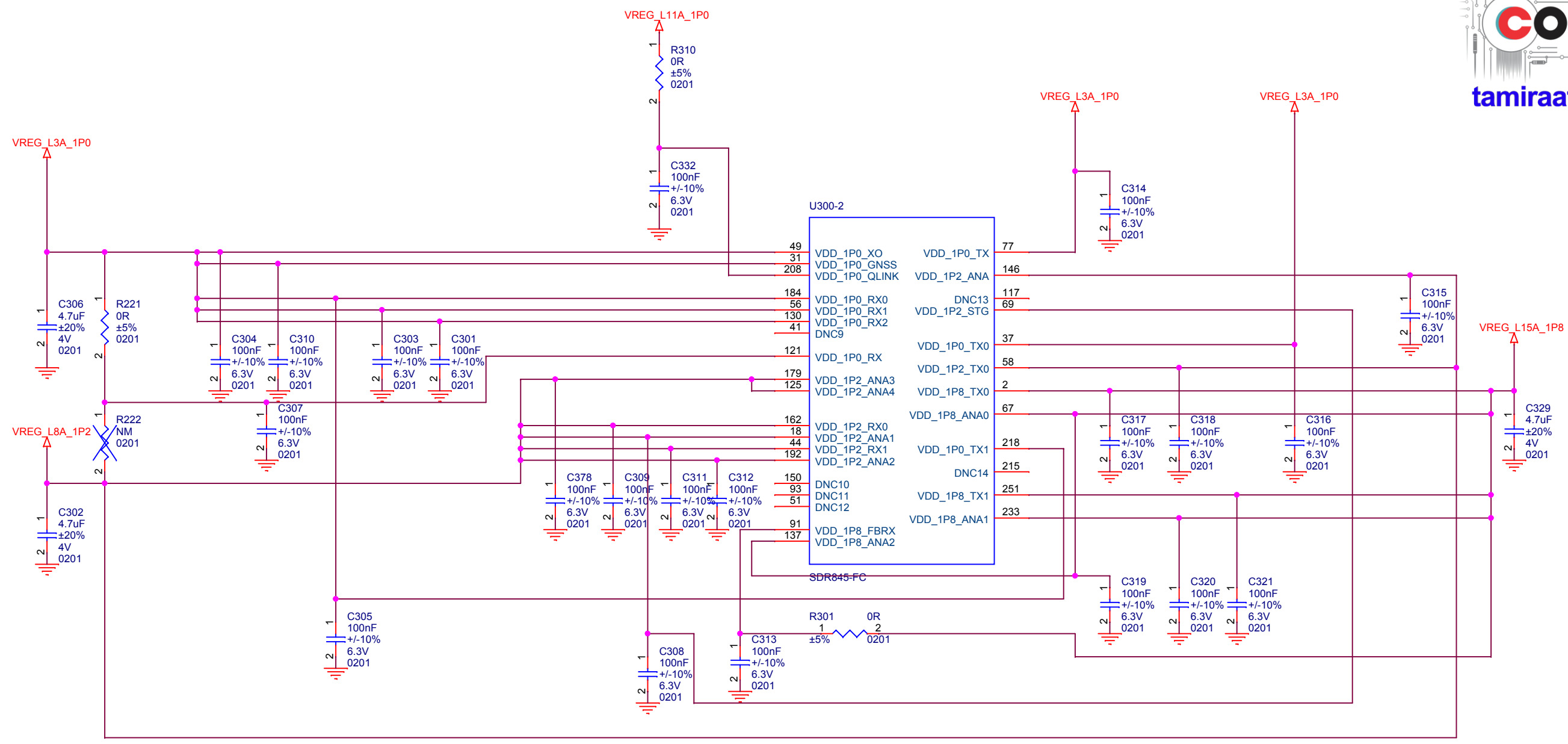

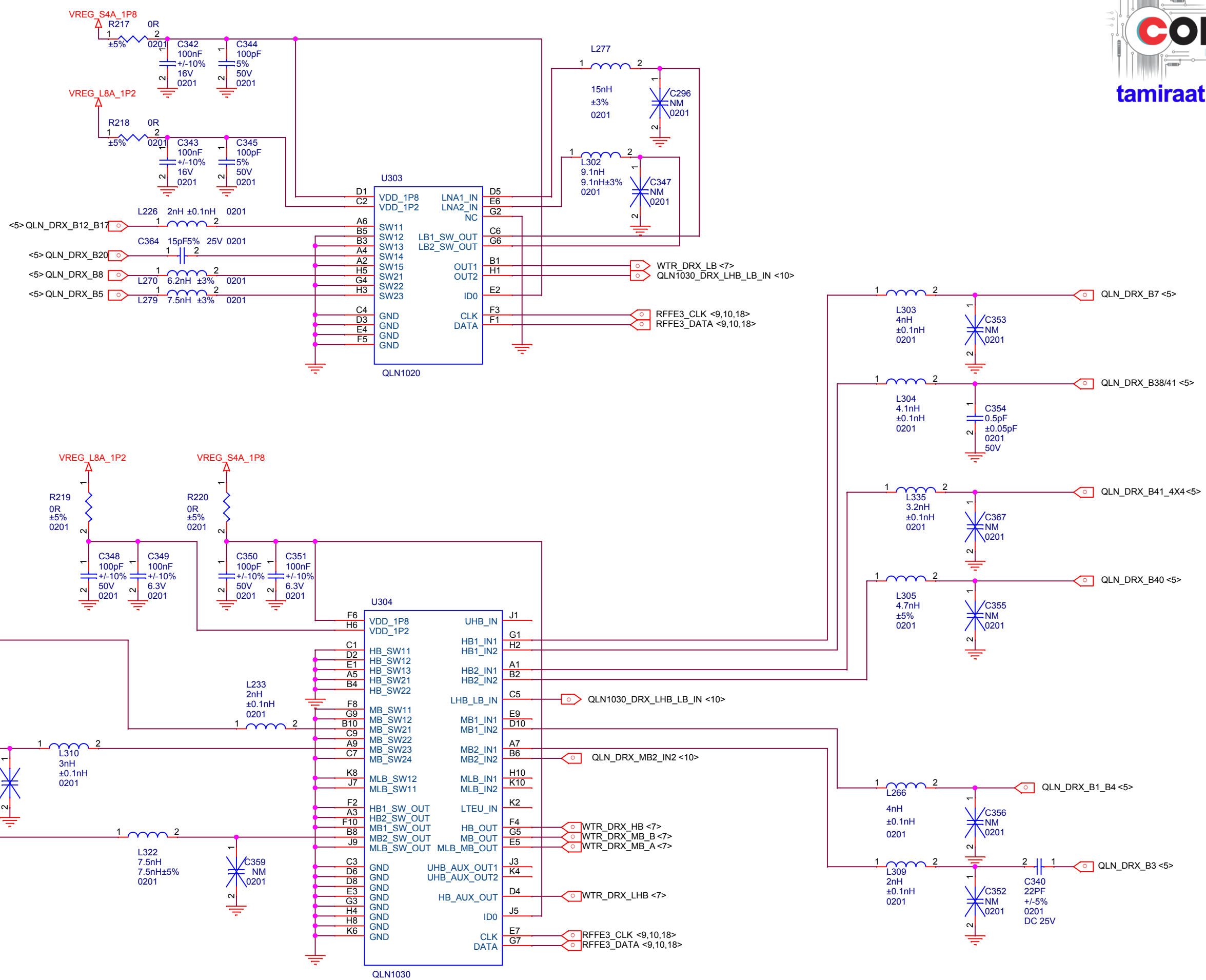

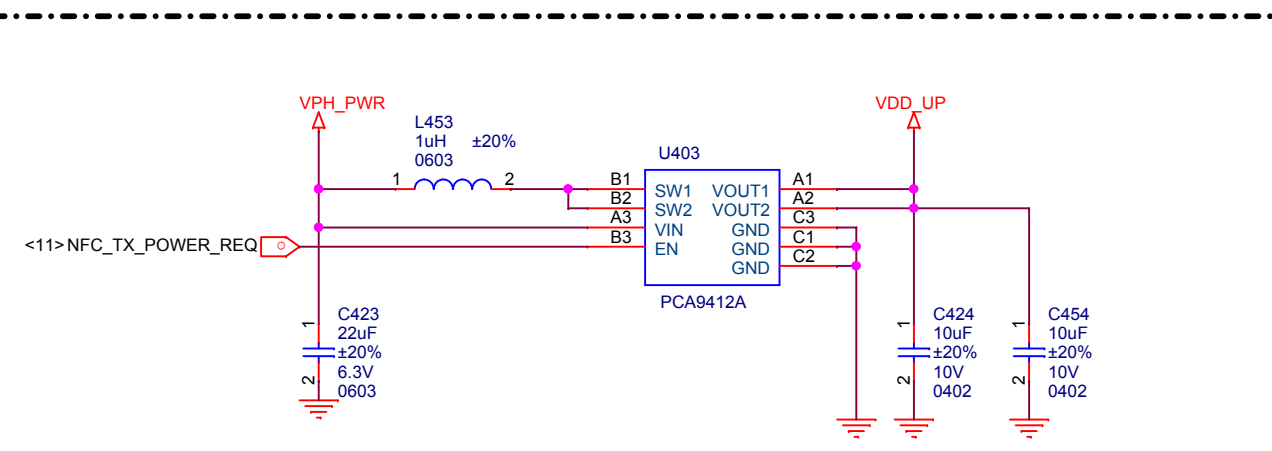
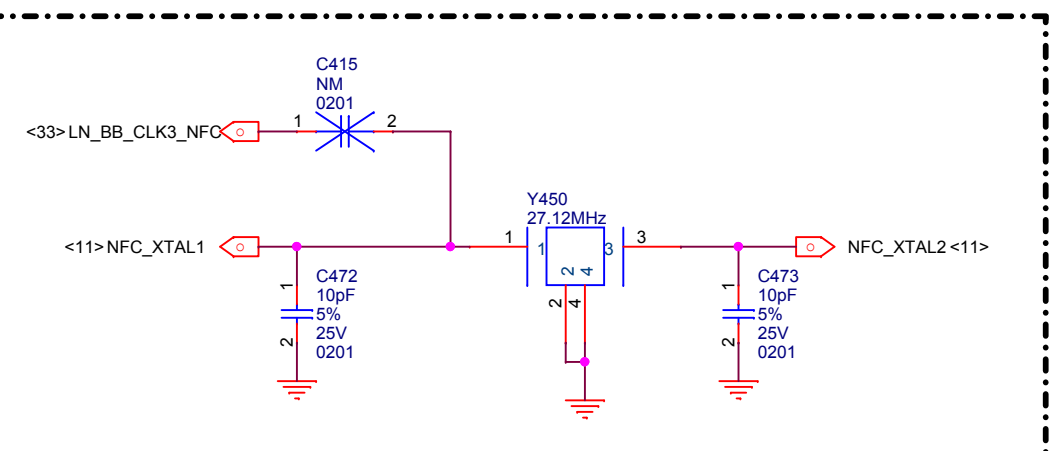
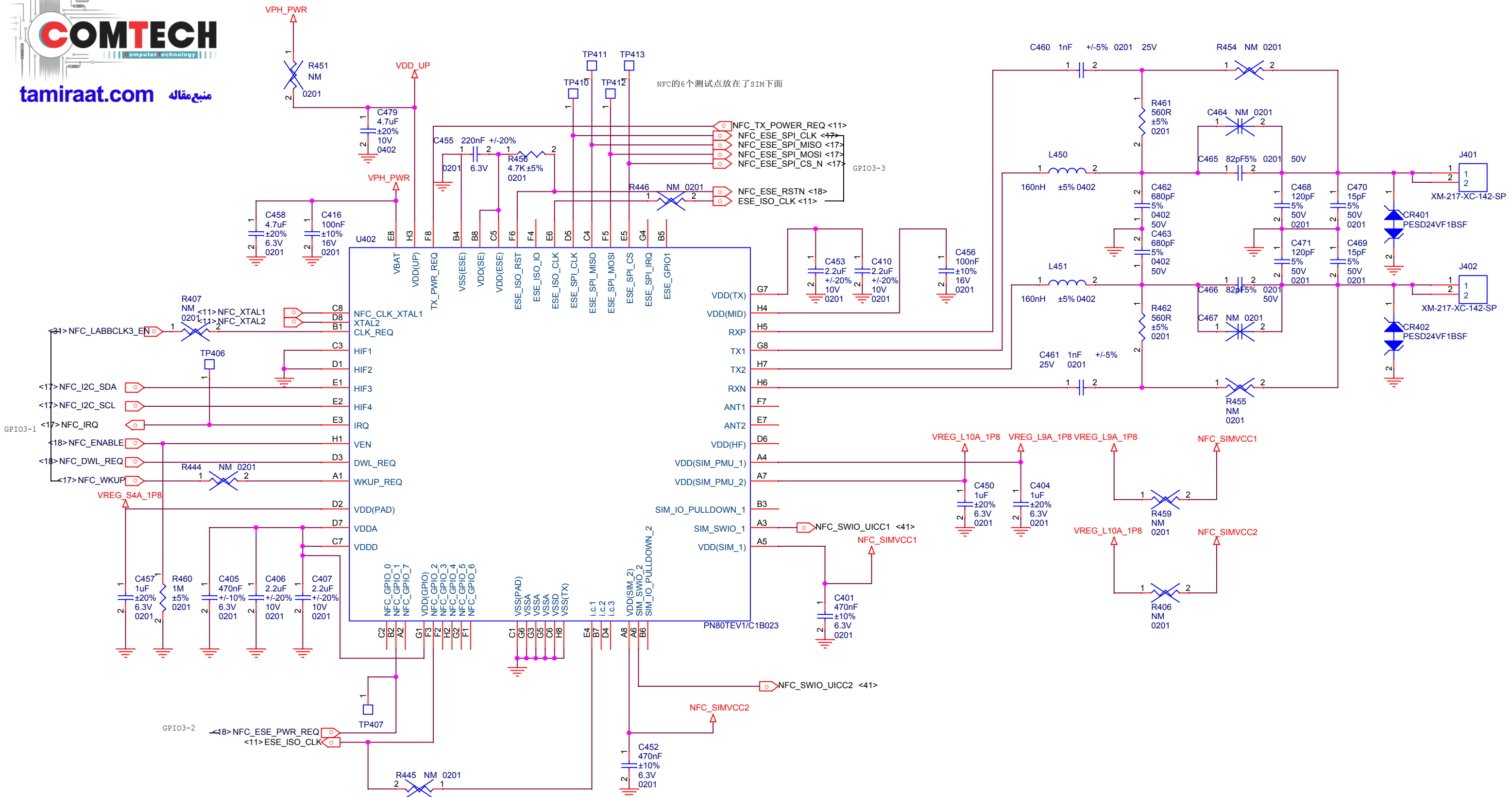

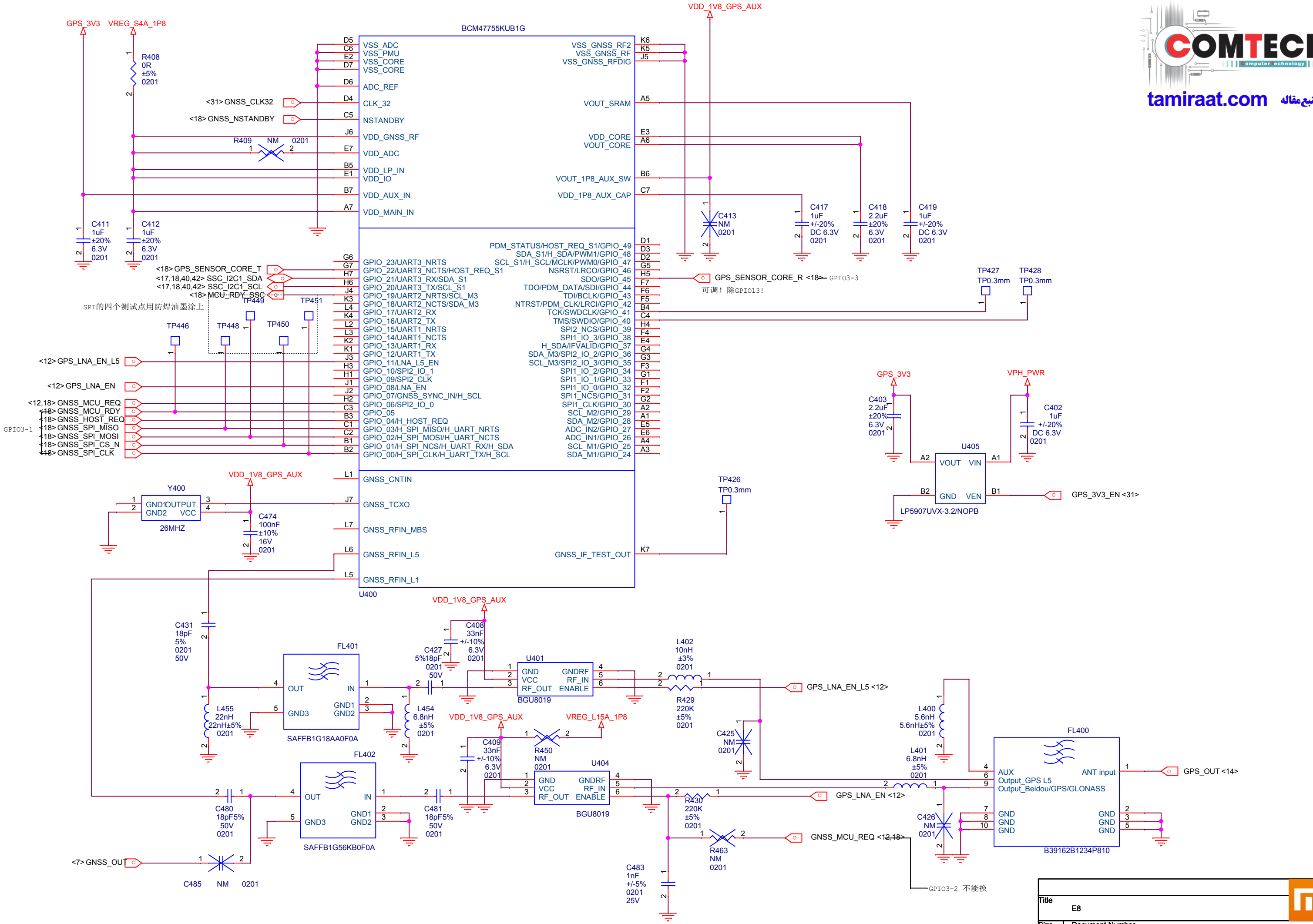

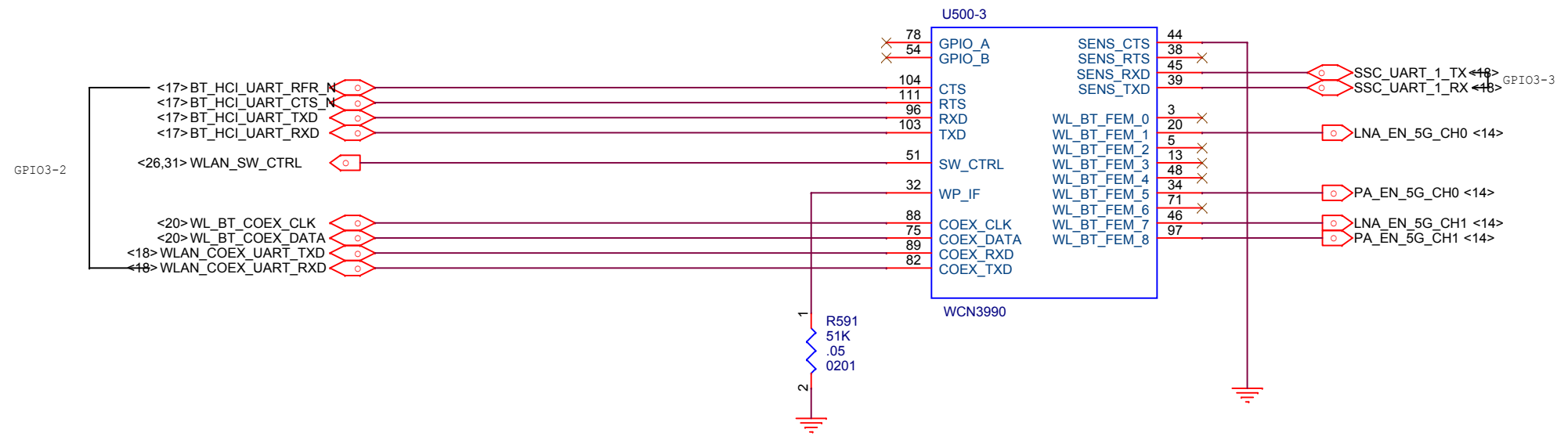
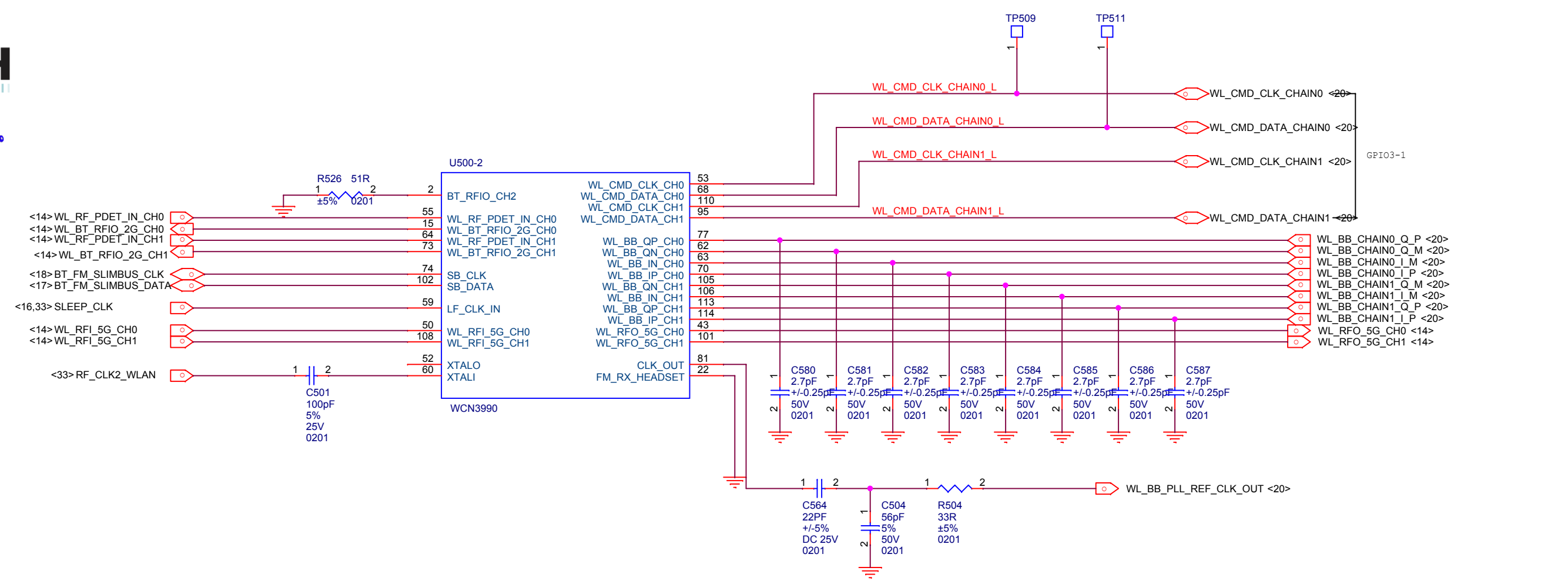

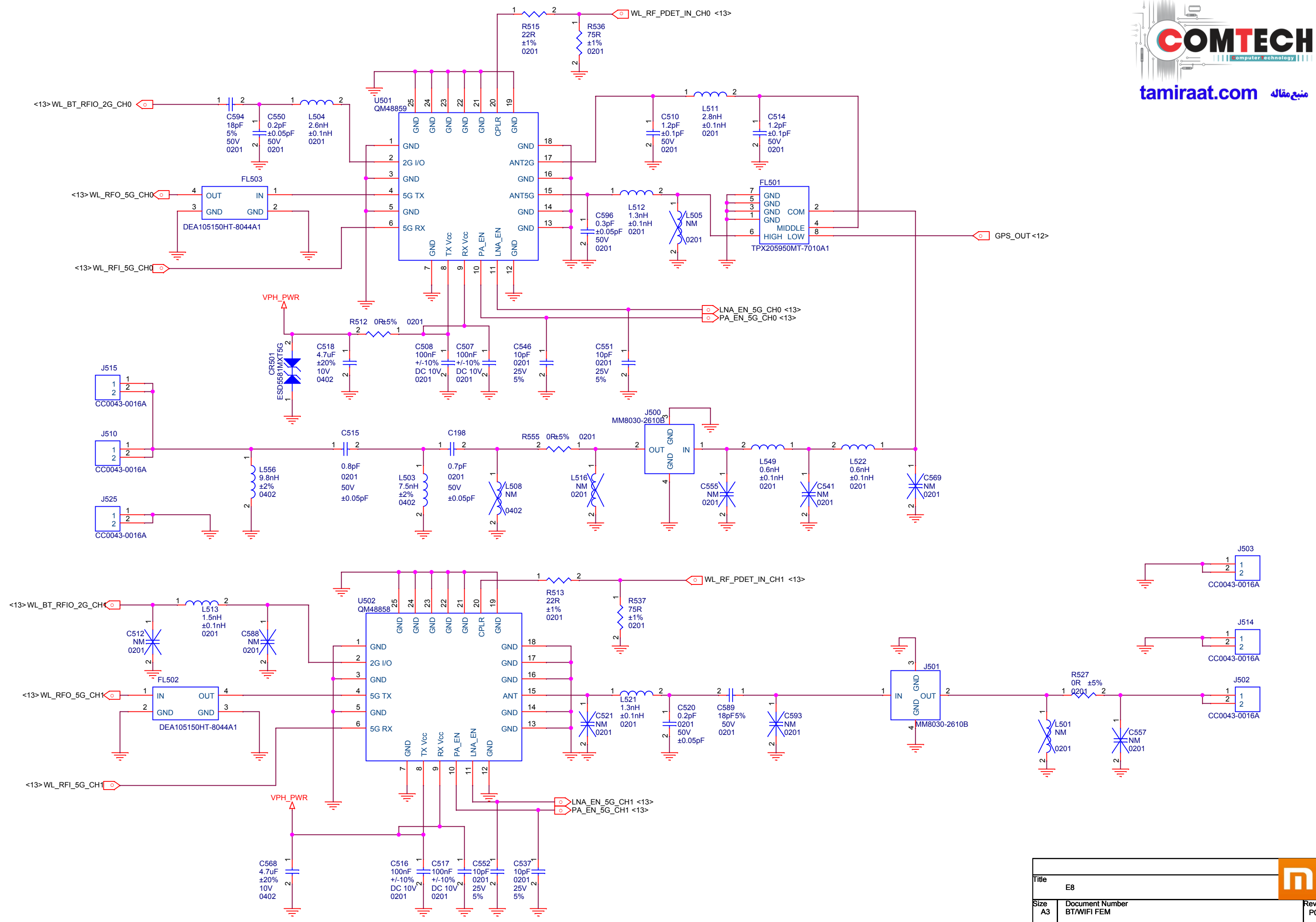

Title		E8	
Size	Document Number	BT/WIFI FEM	
Date:	Friday, March 23, 2018	Sheet	14 of 44
Rev	P0		

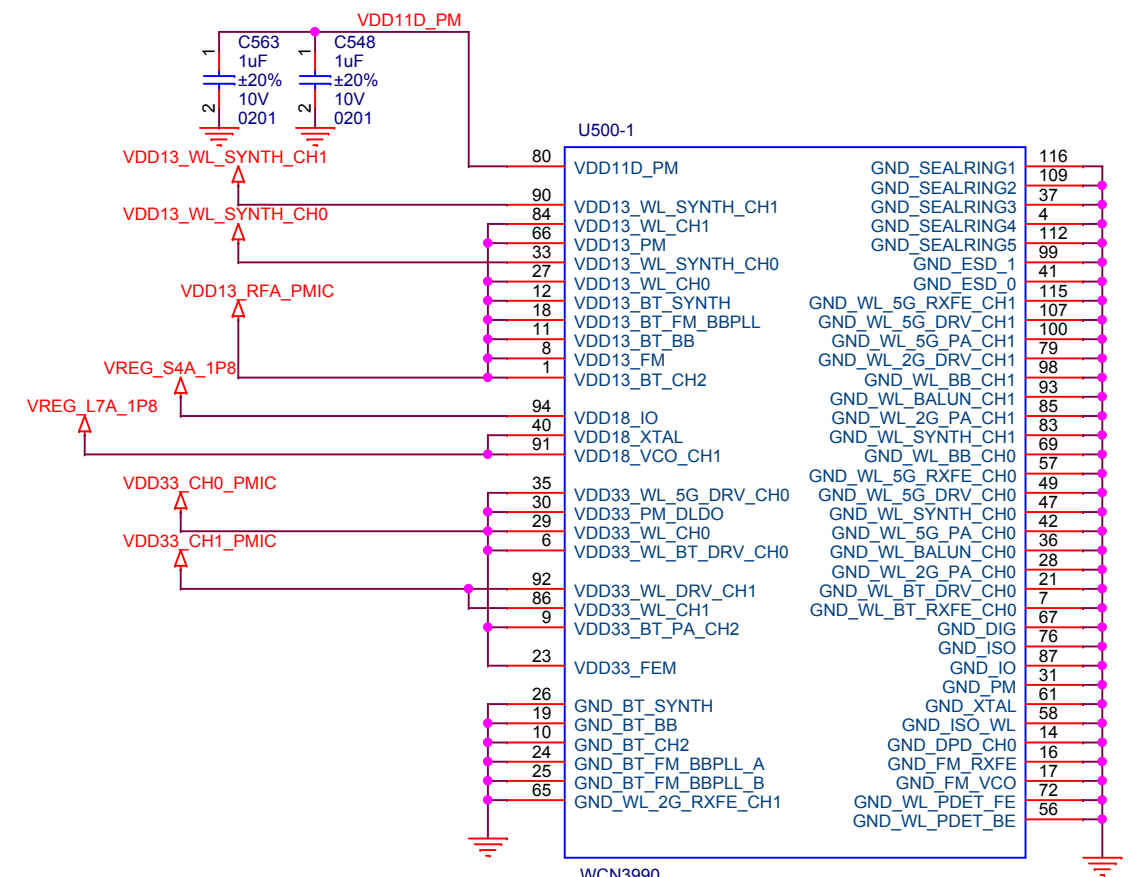
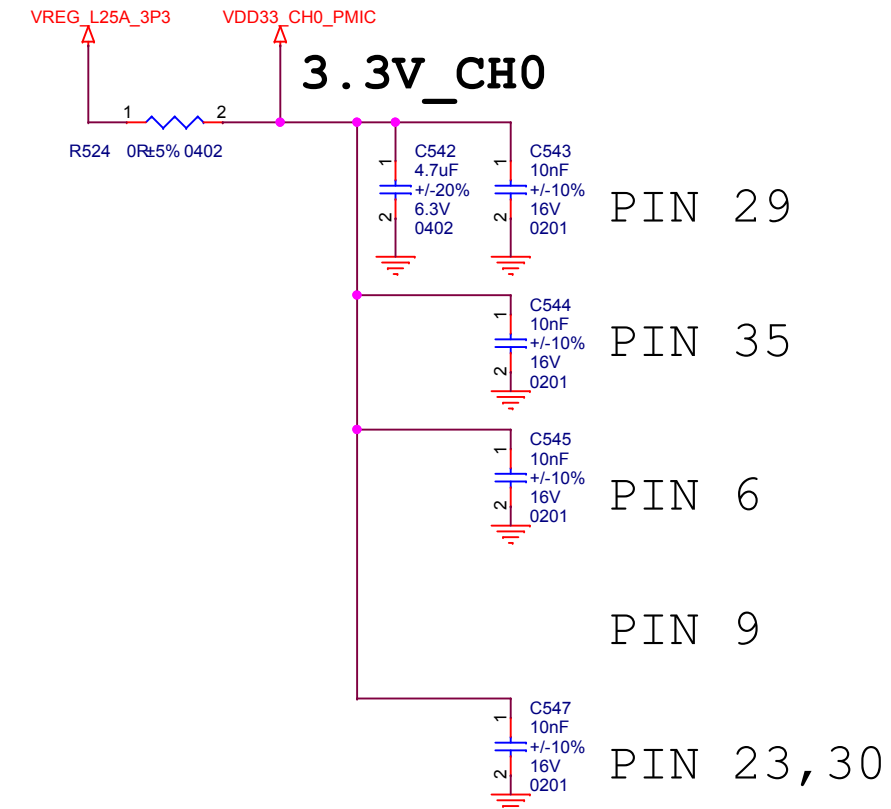
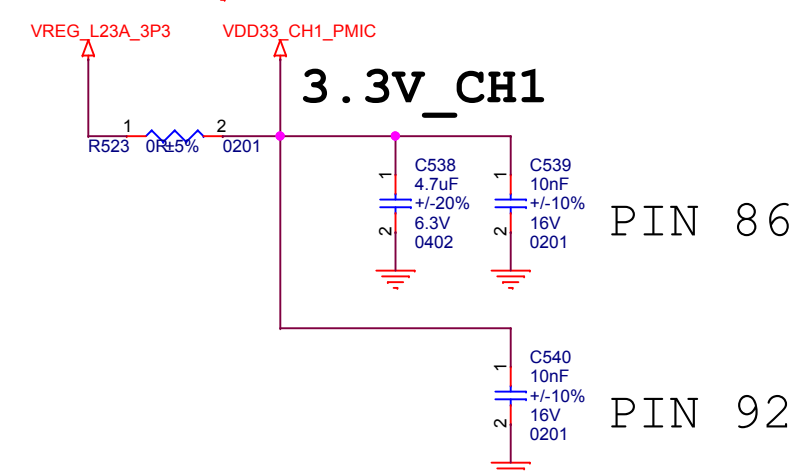
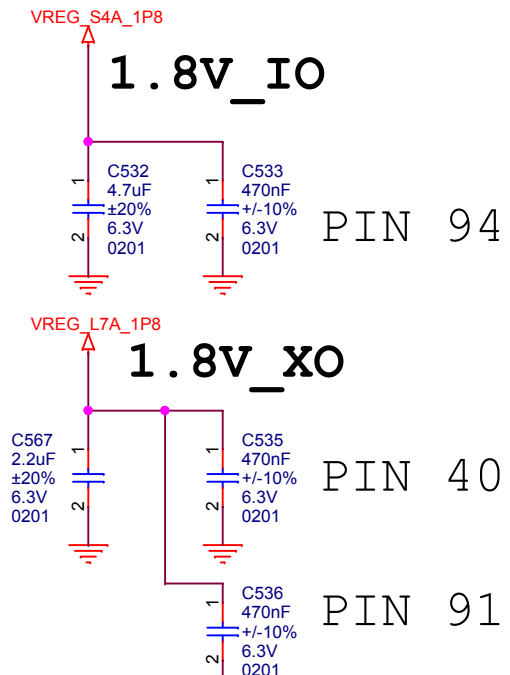
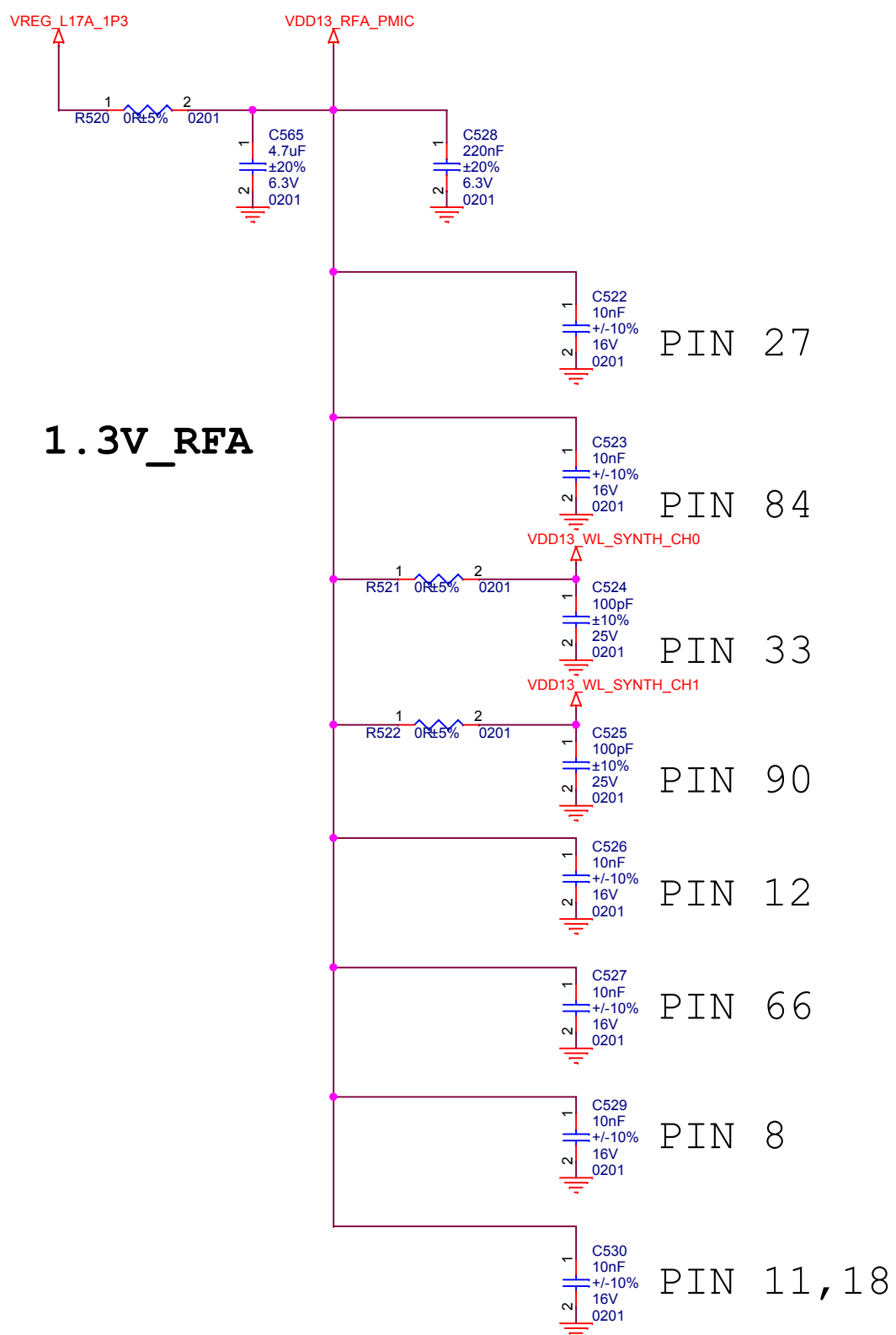

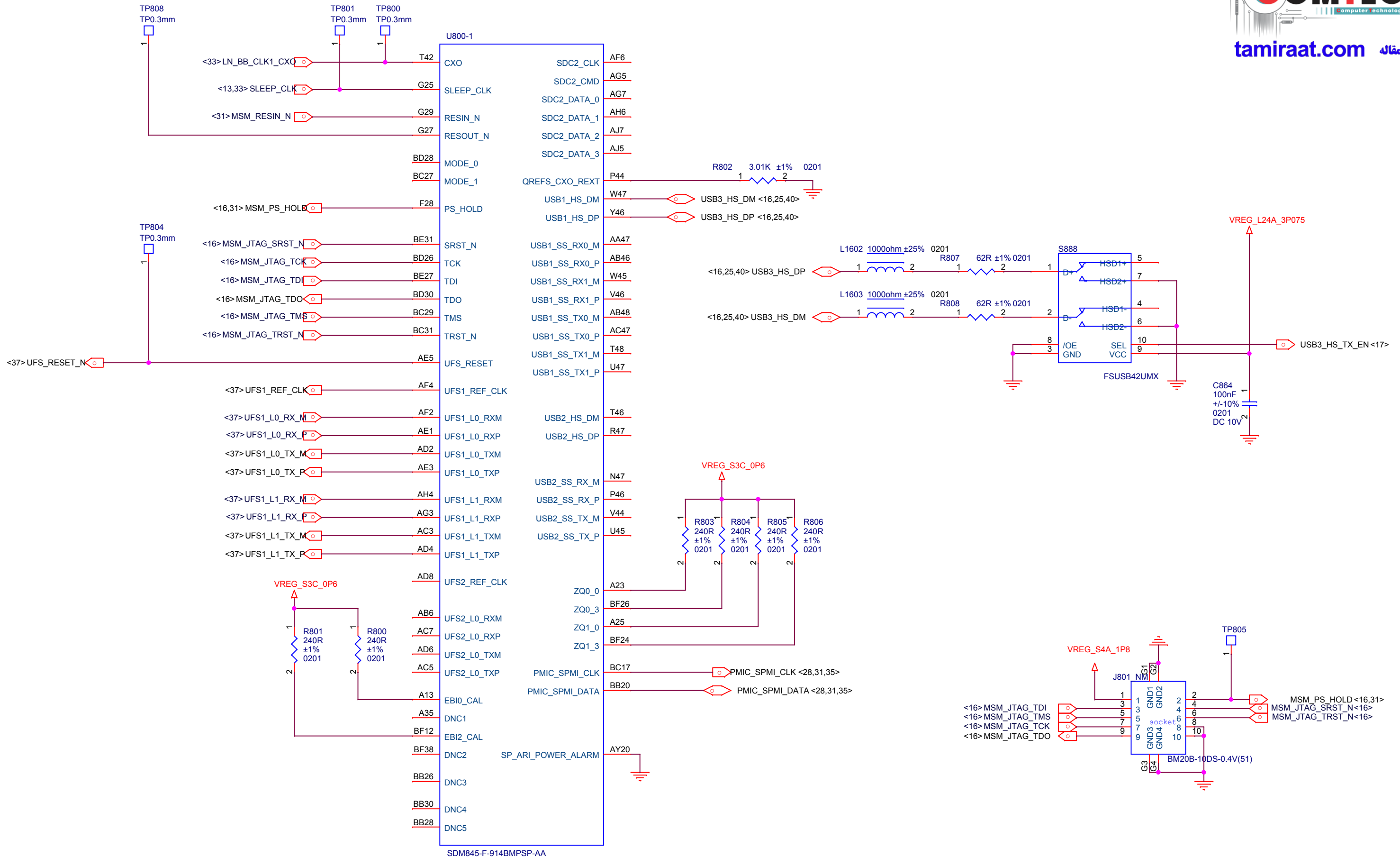

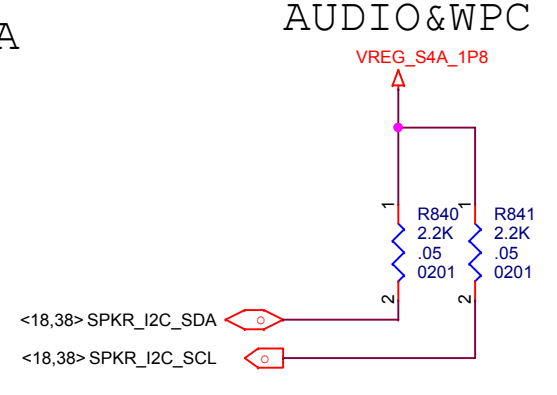
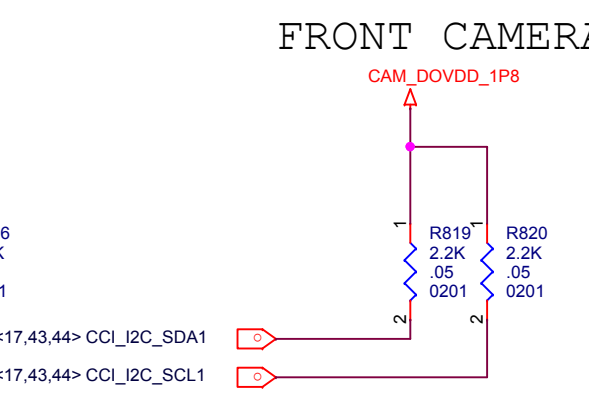
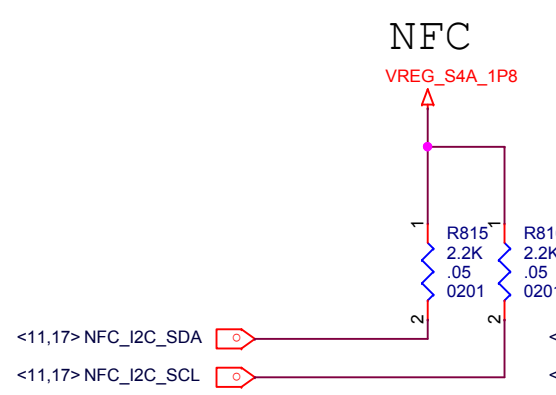
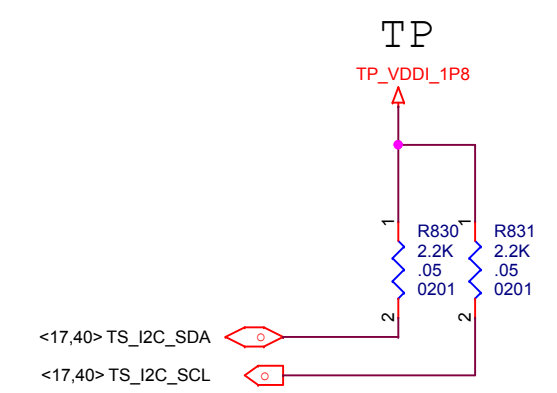
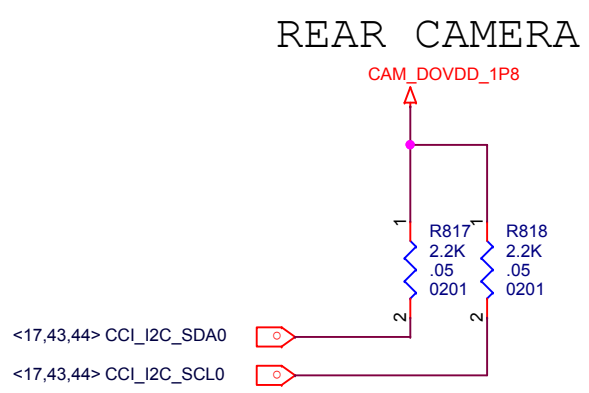
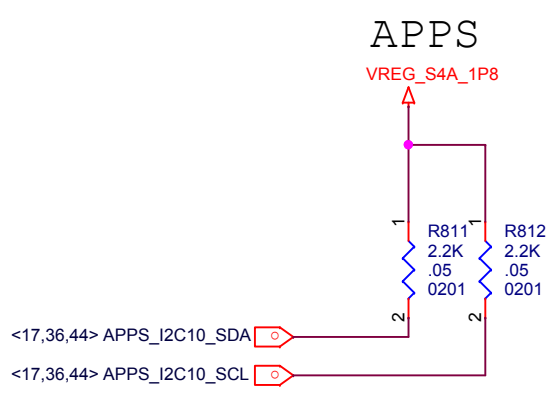
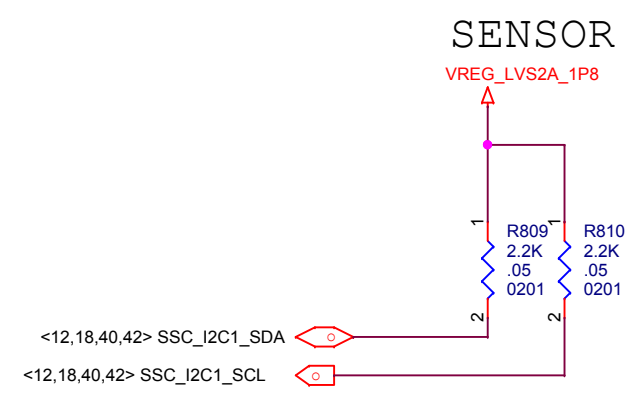
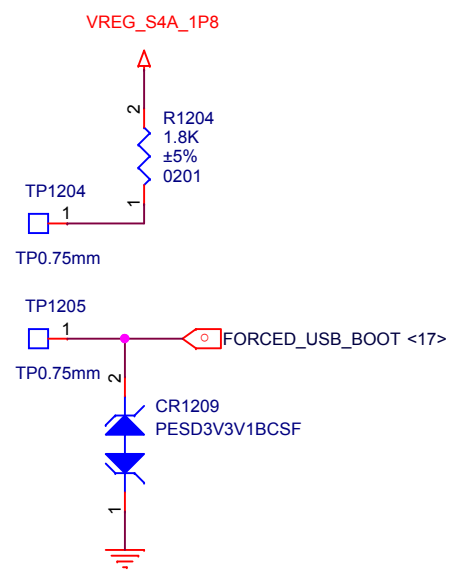
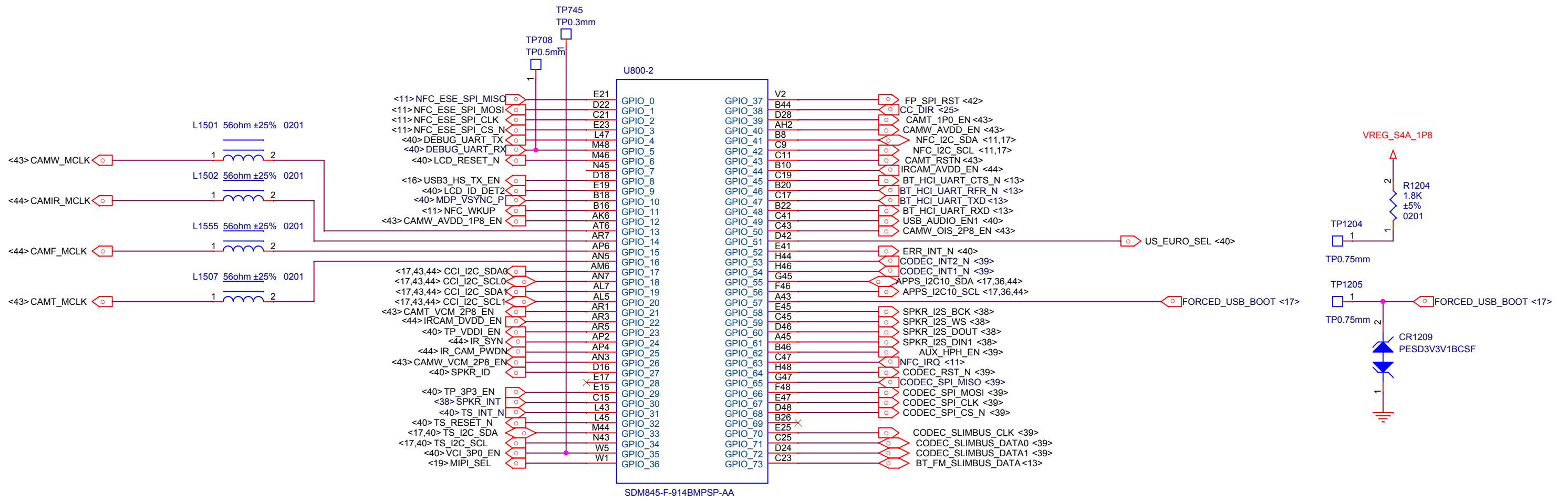

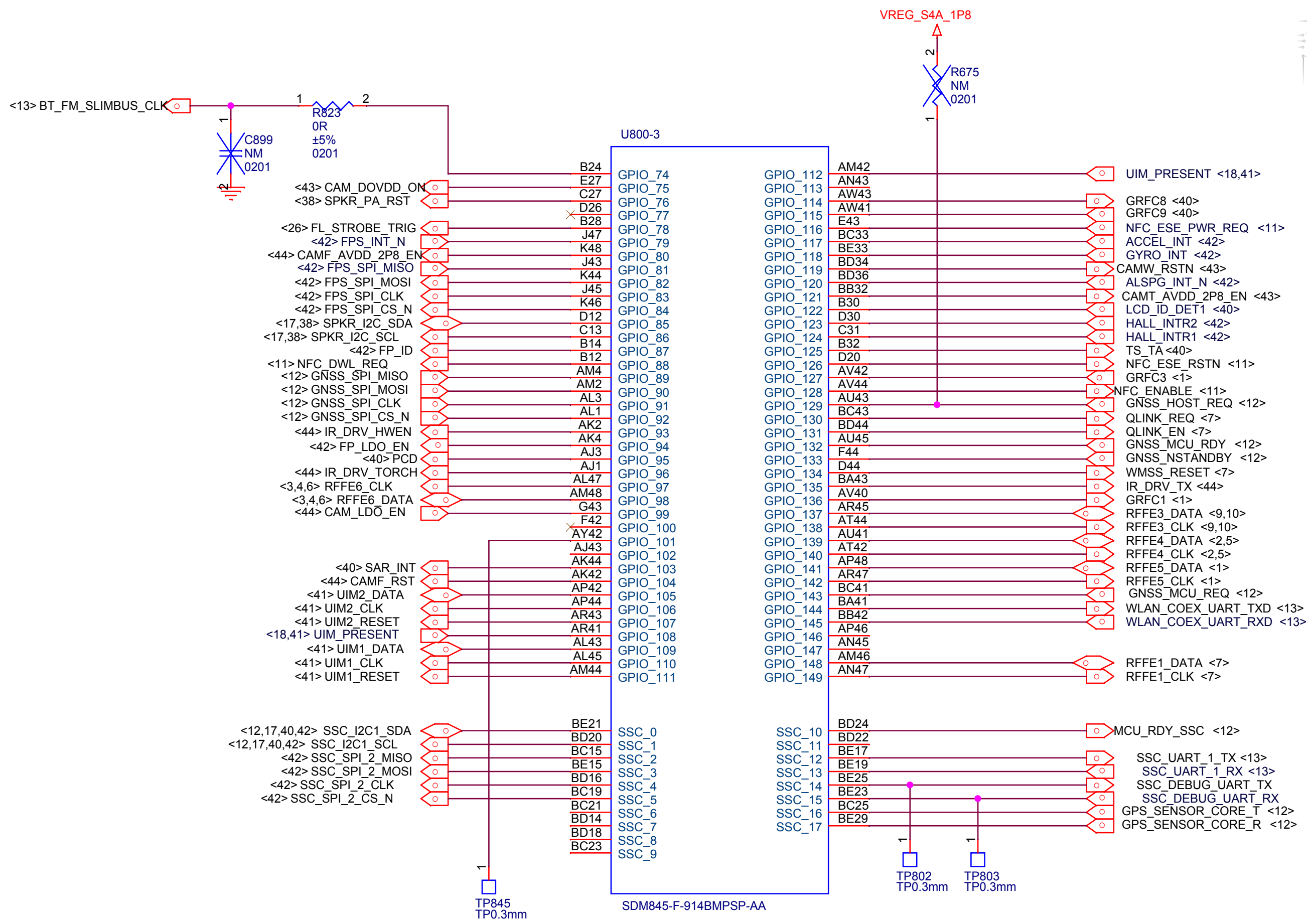

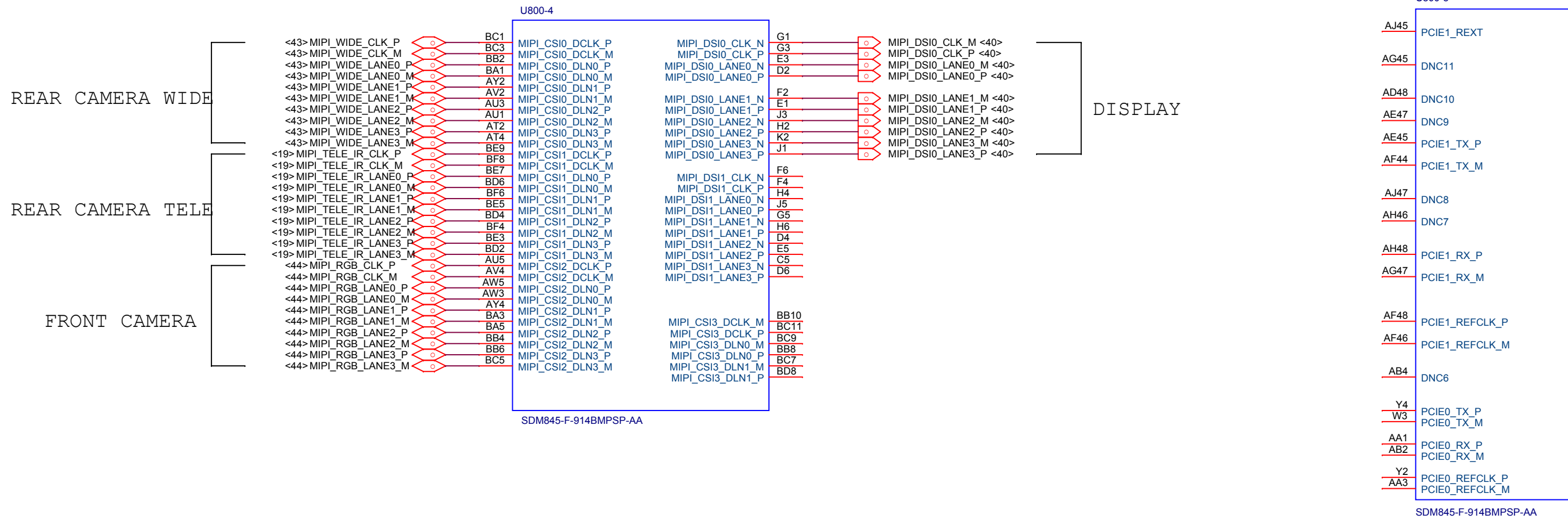

TELE-IR SWITCH

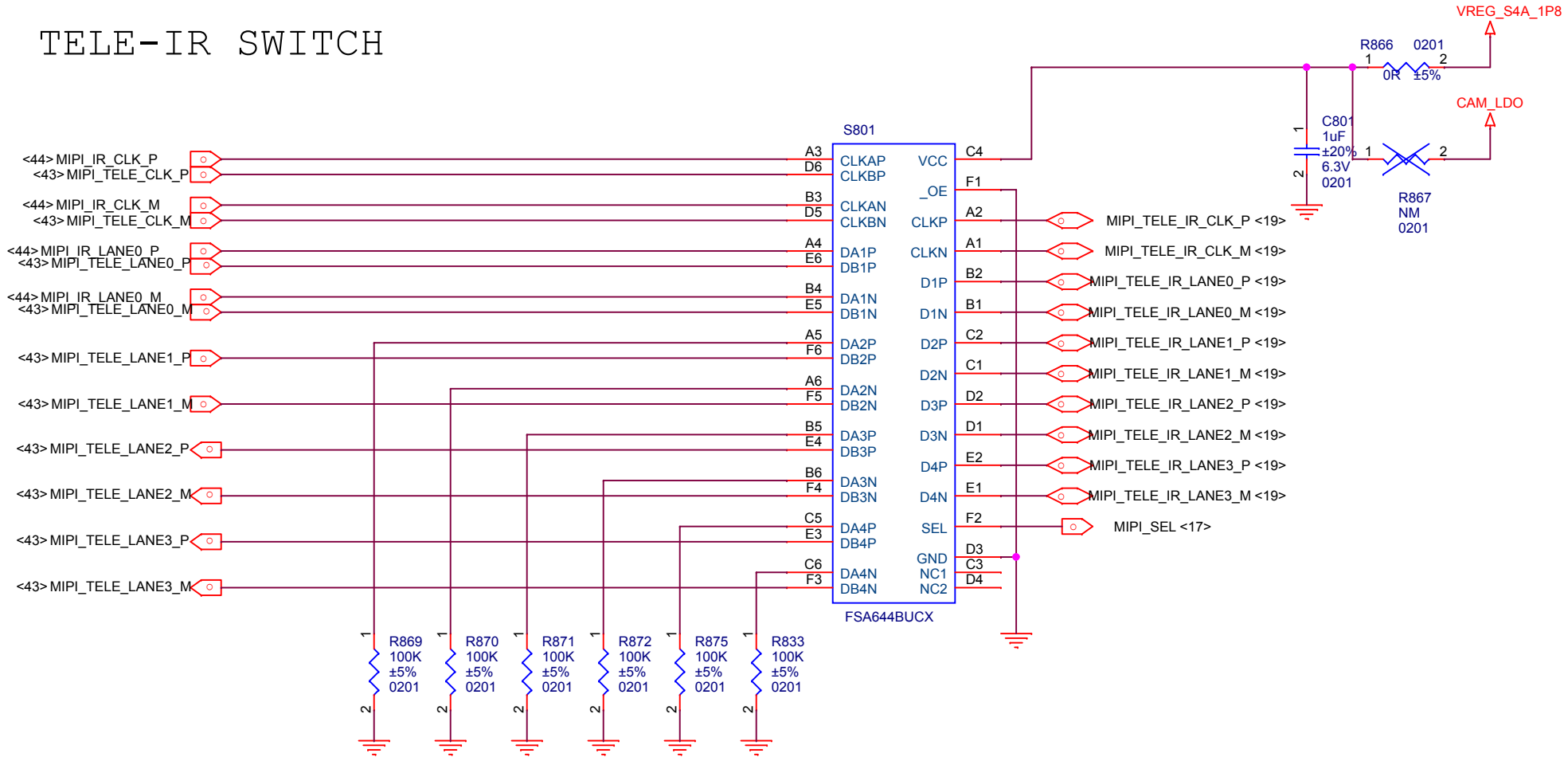

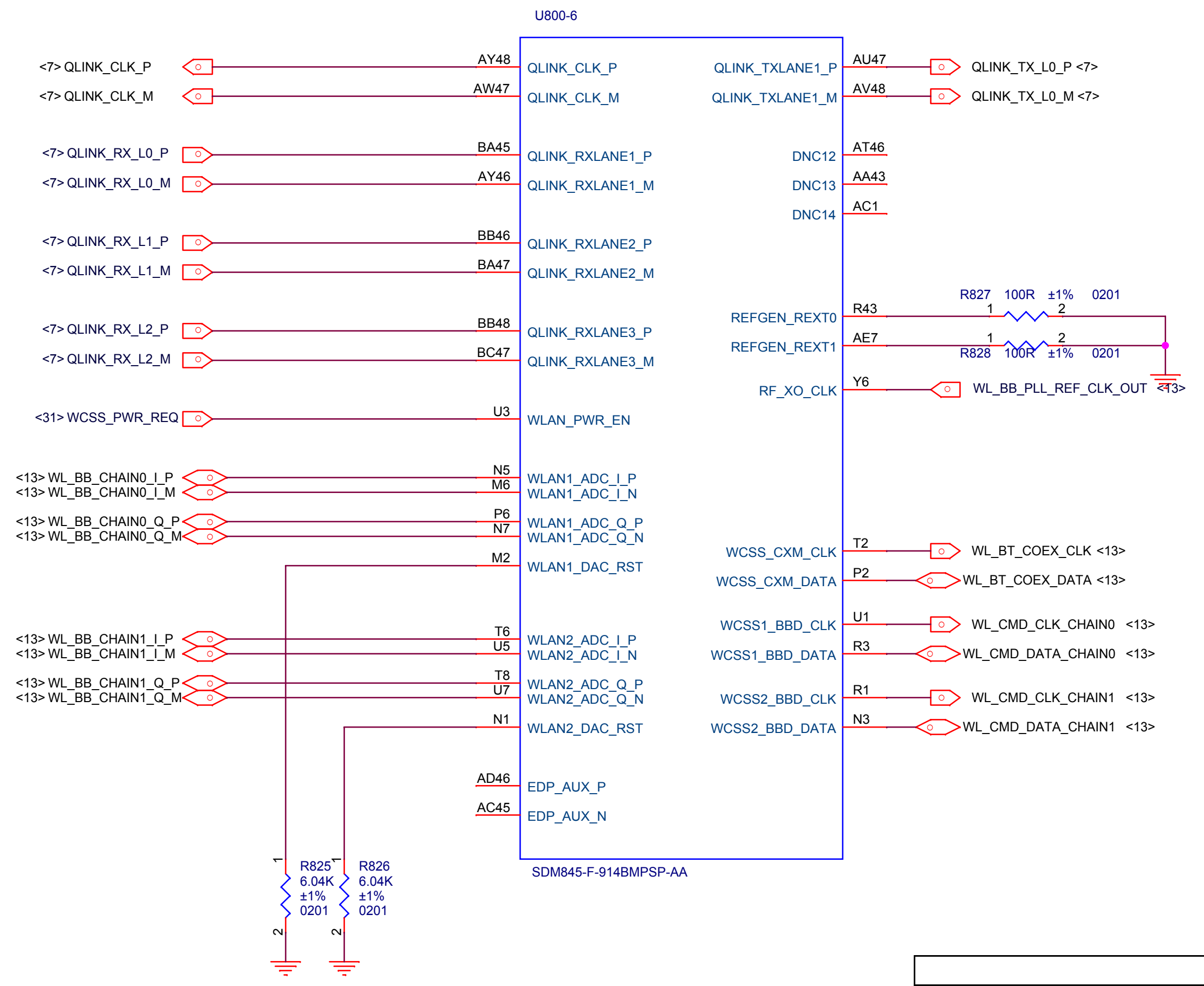

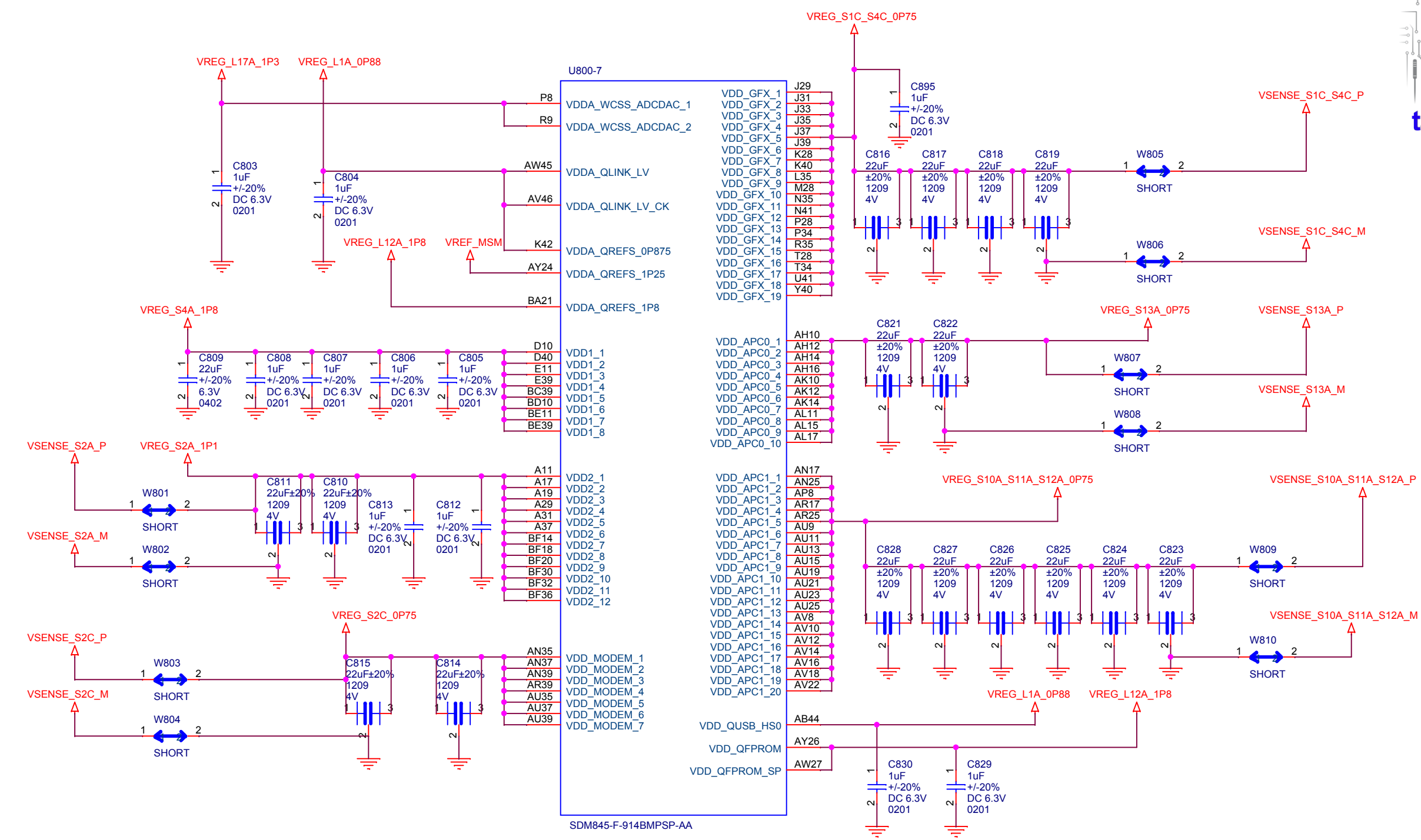

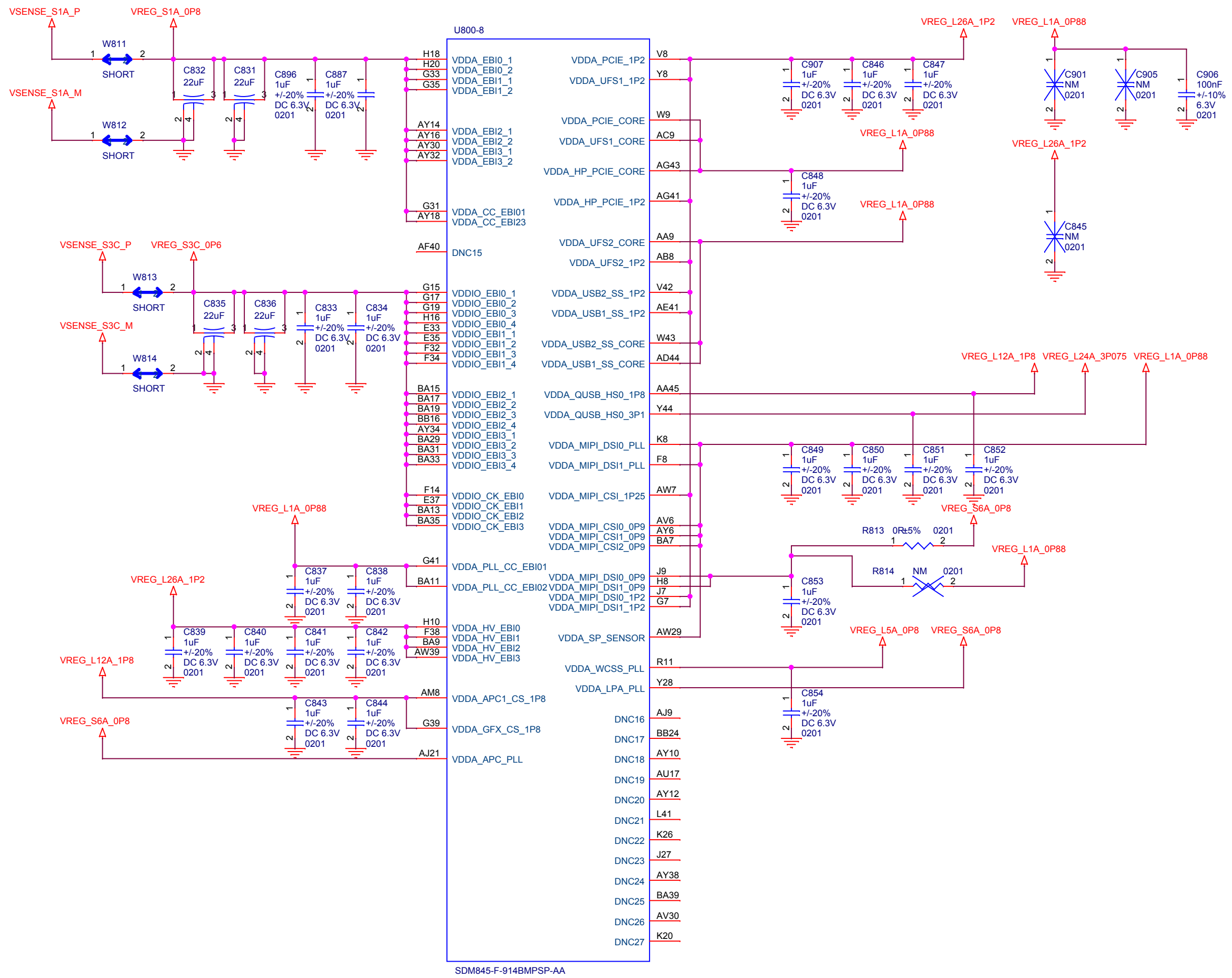

SDM845-F-914BMPSP-AA

Title		E8	
Size	Document Number	SDM845 PWR2	
Date:	Friday, March 23, 2018	Sheet	22 of 44

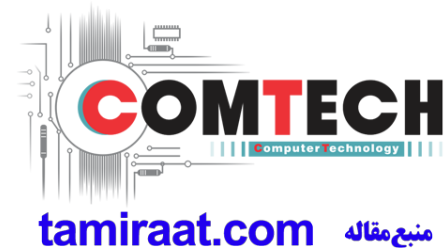
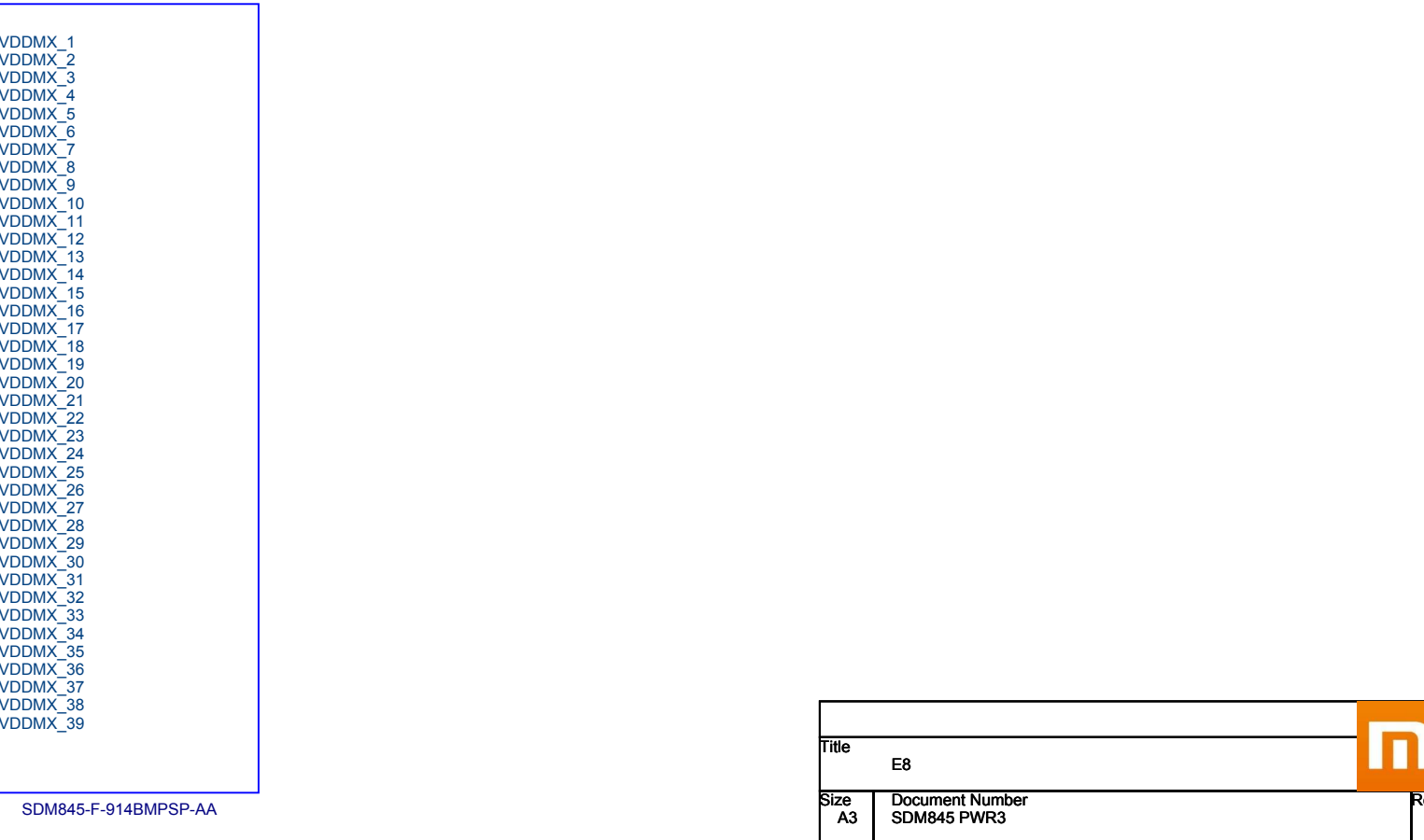
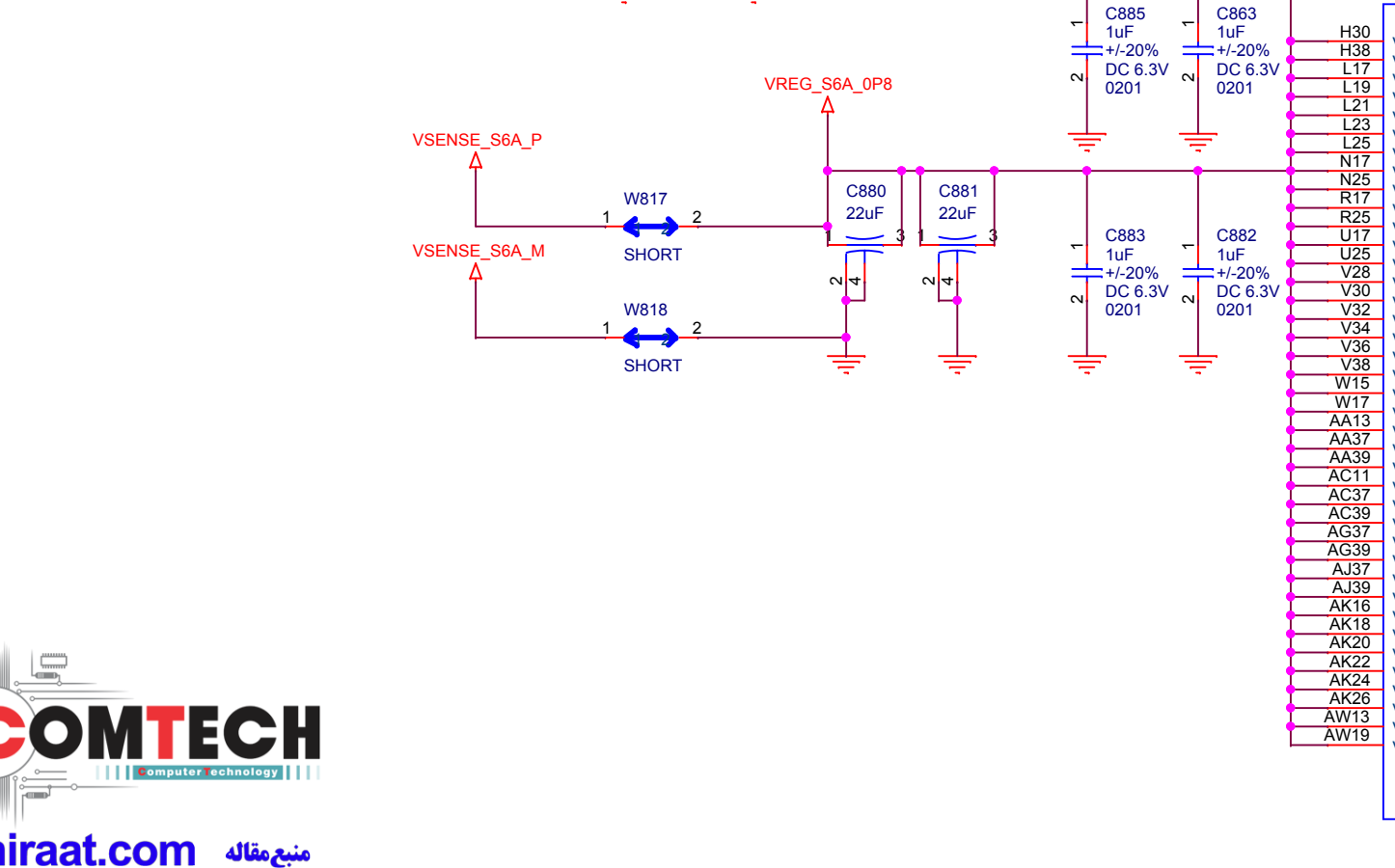
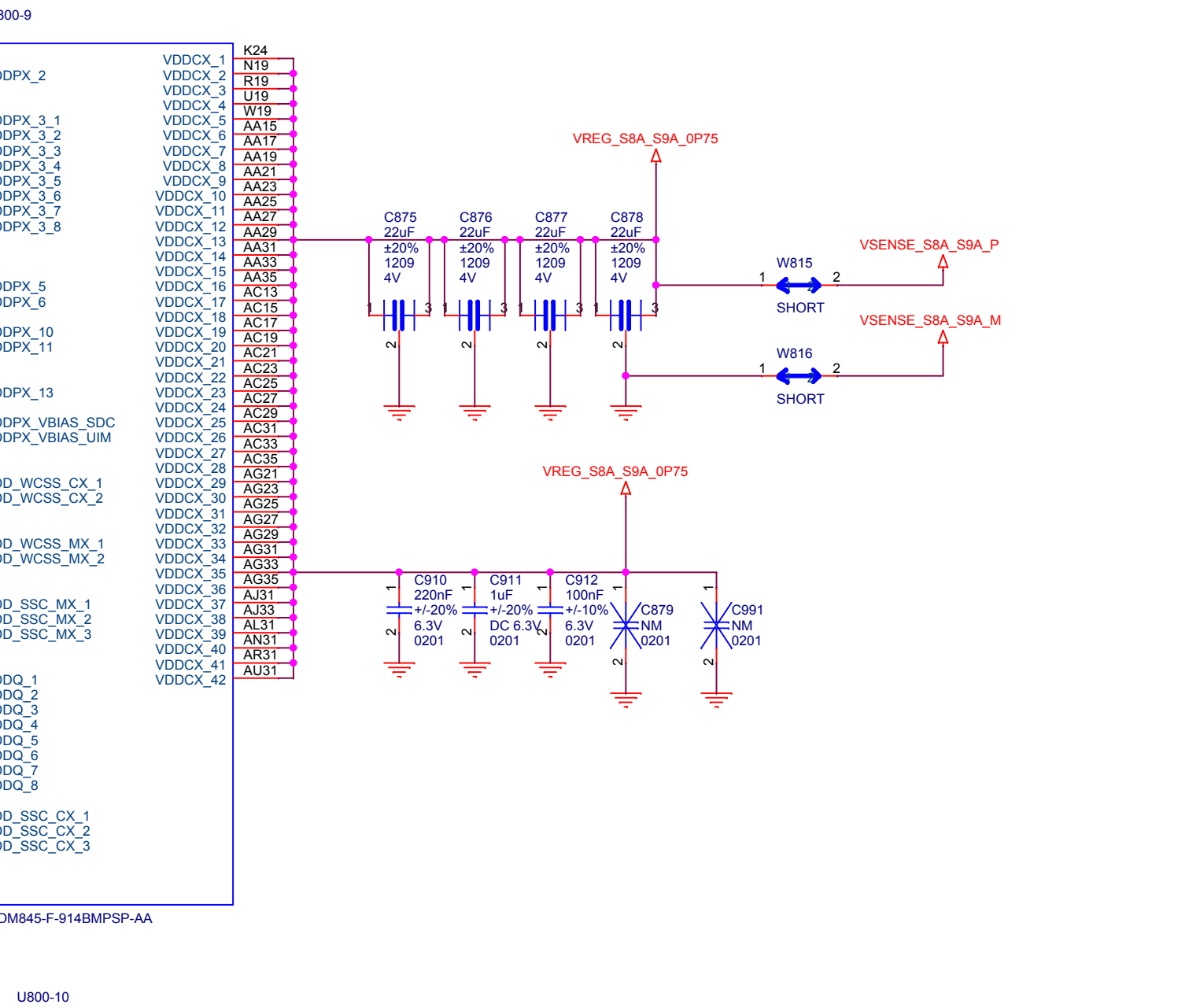
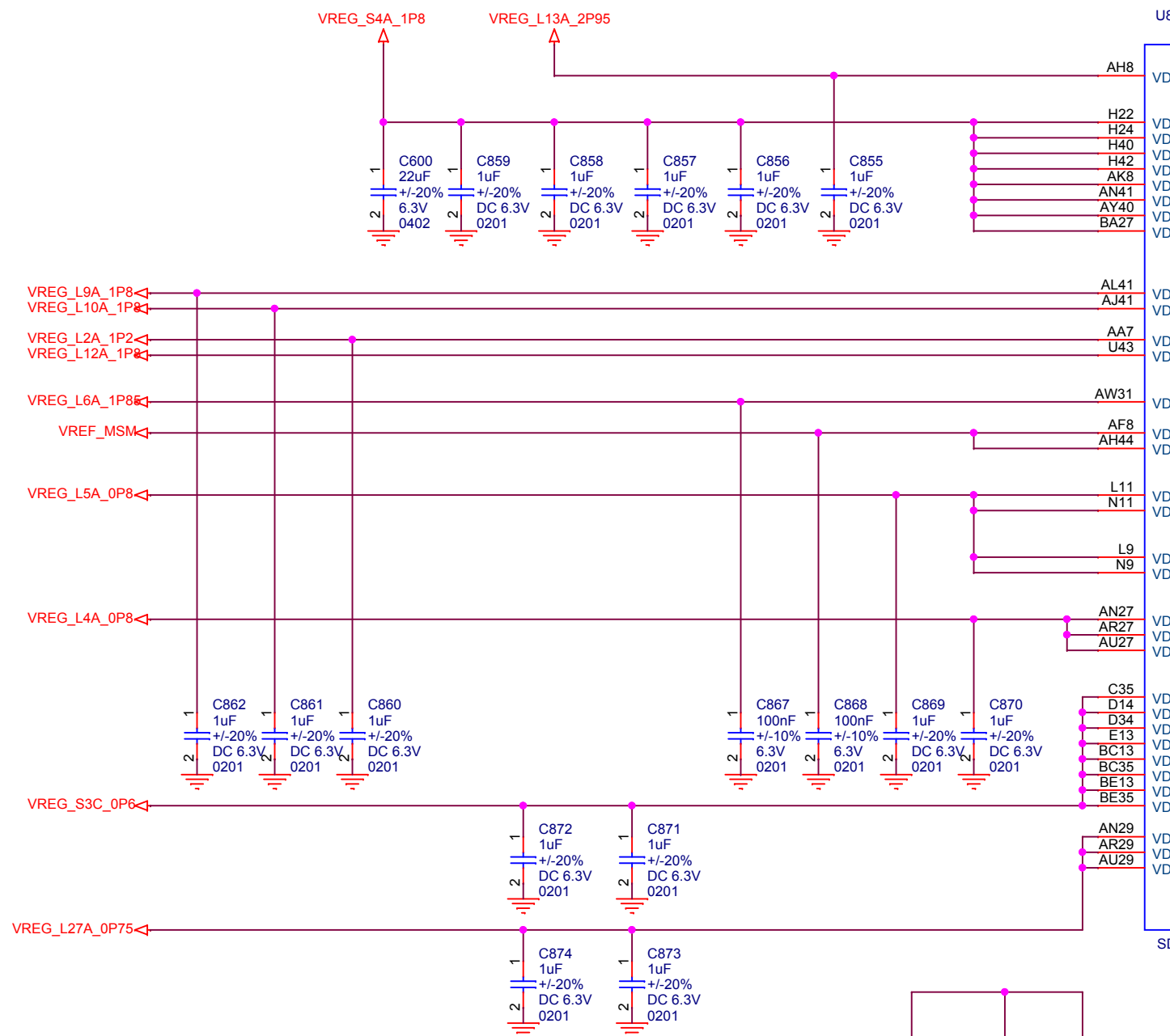

Title		E8	Rev P0
Size	Document Number		
A3	SDM845 PWR3		
Date:	Friday, March 23, 2018	Sheet 23 of 44	

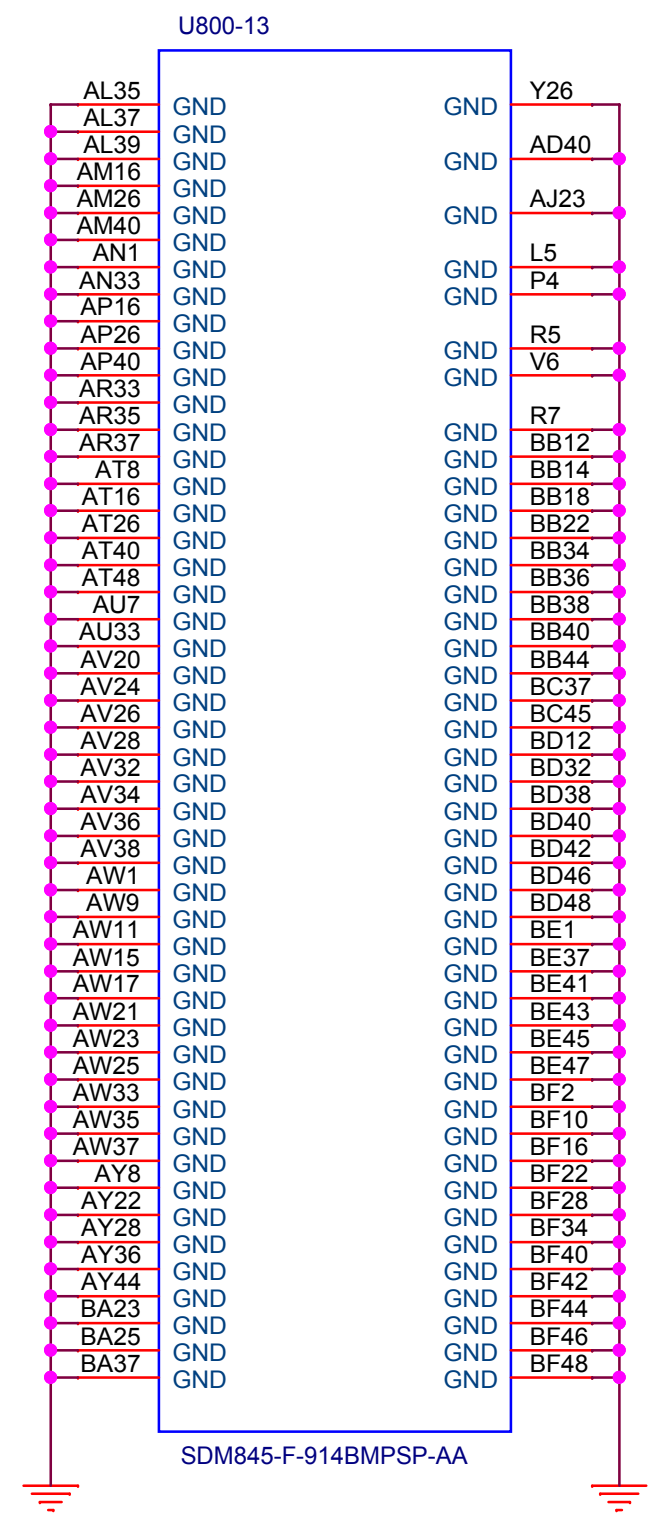
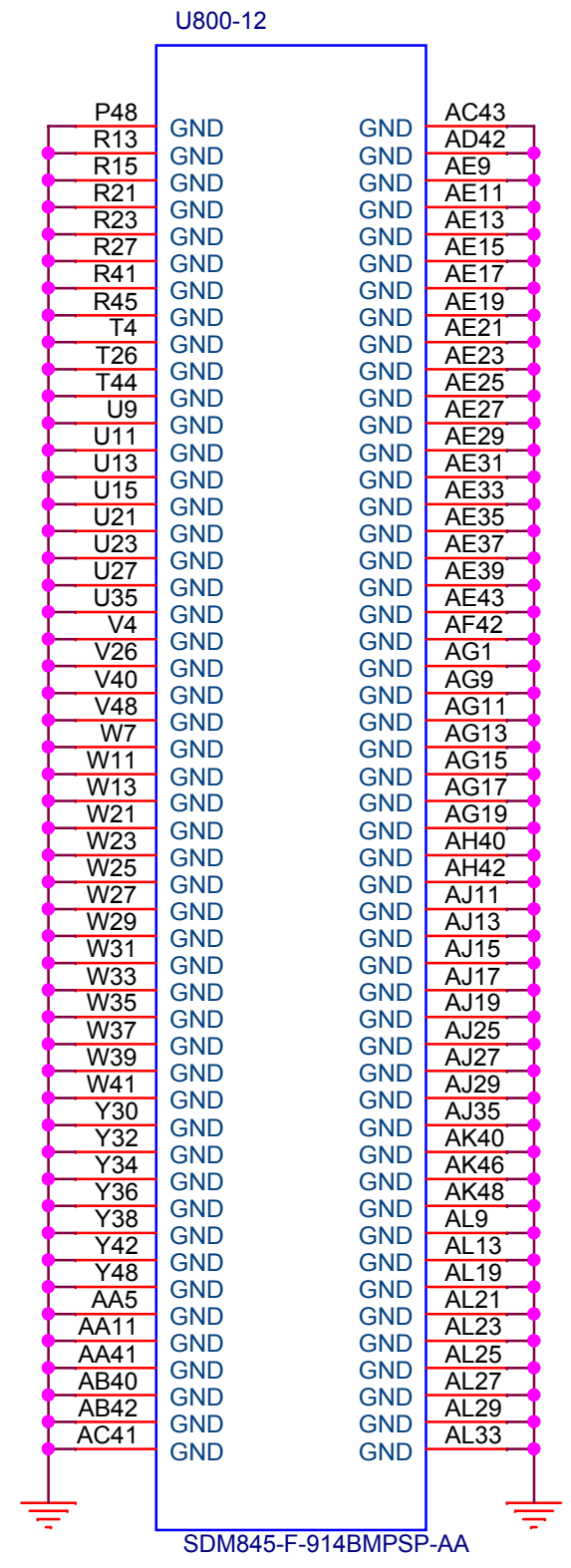
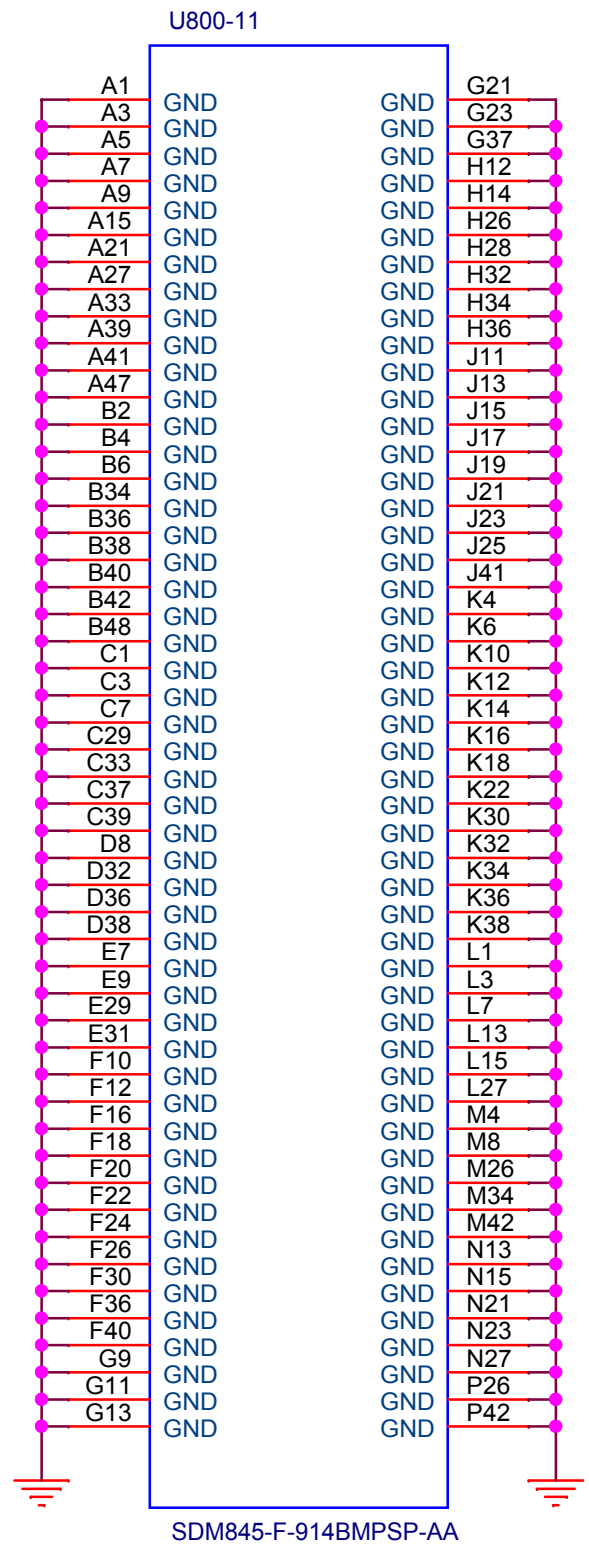

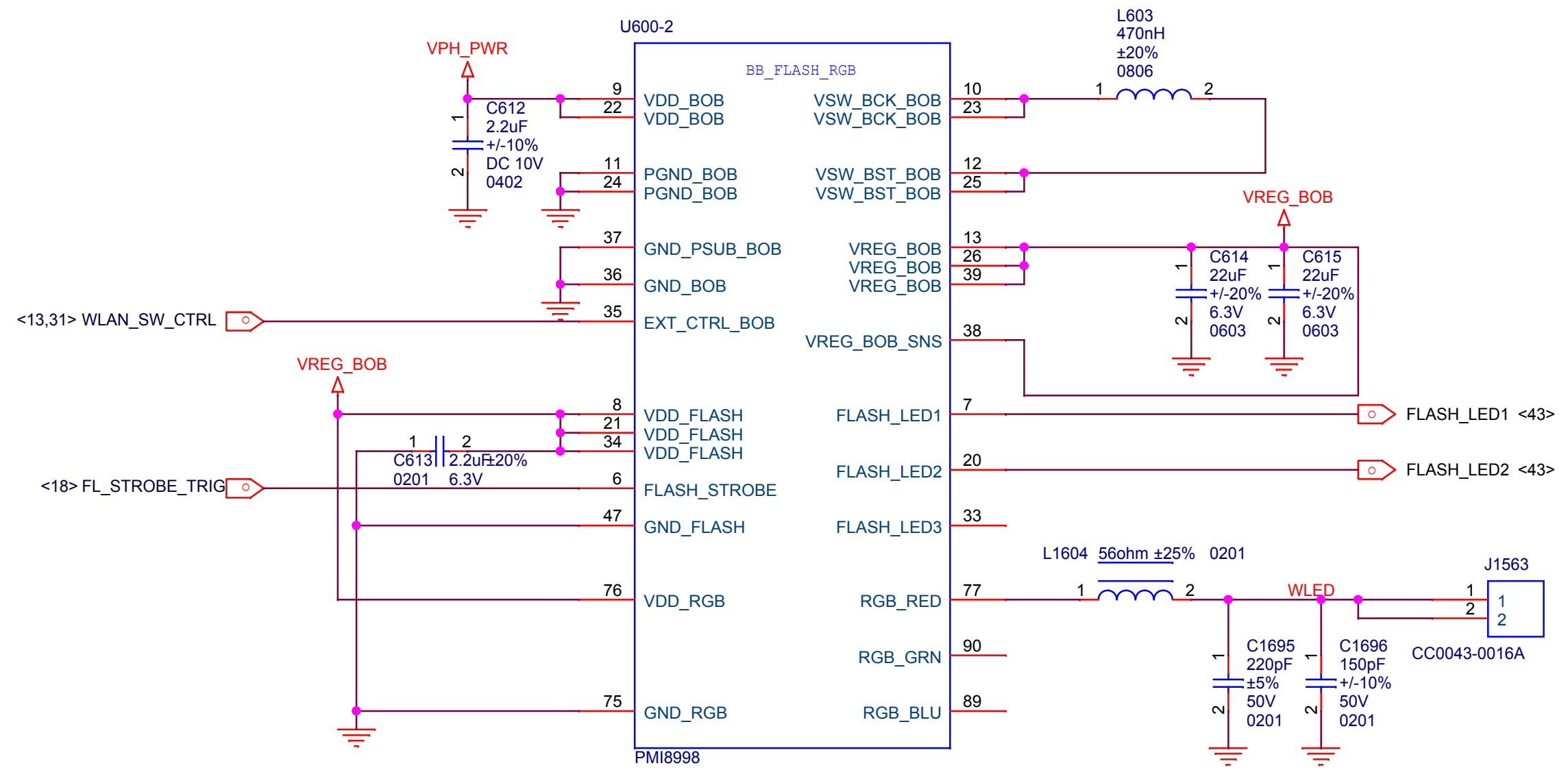

FLASH Board

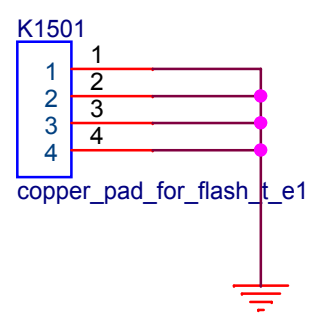

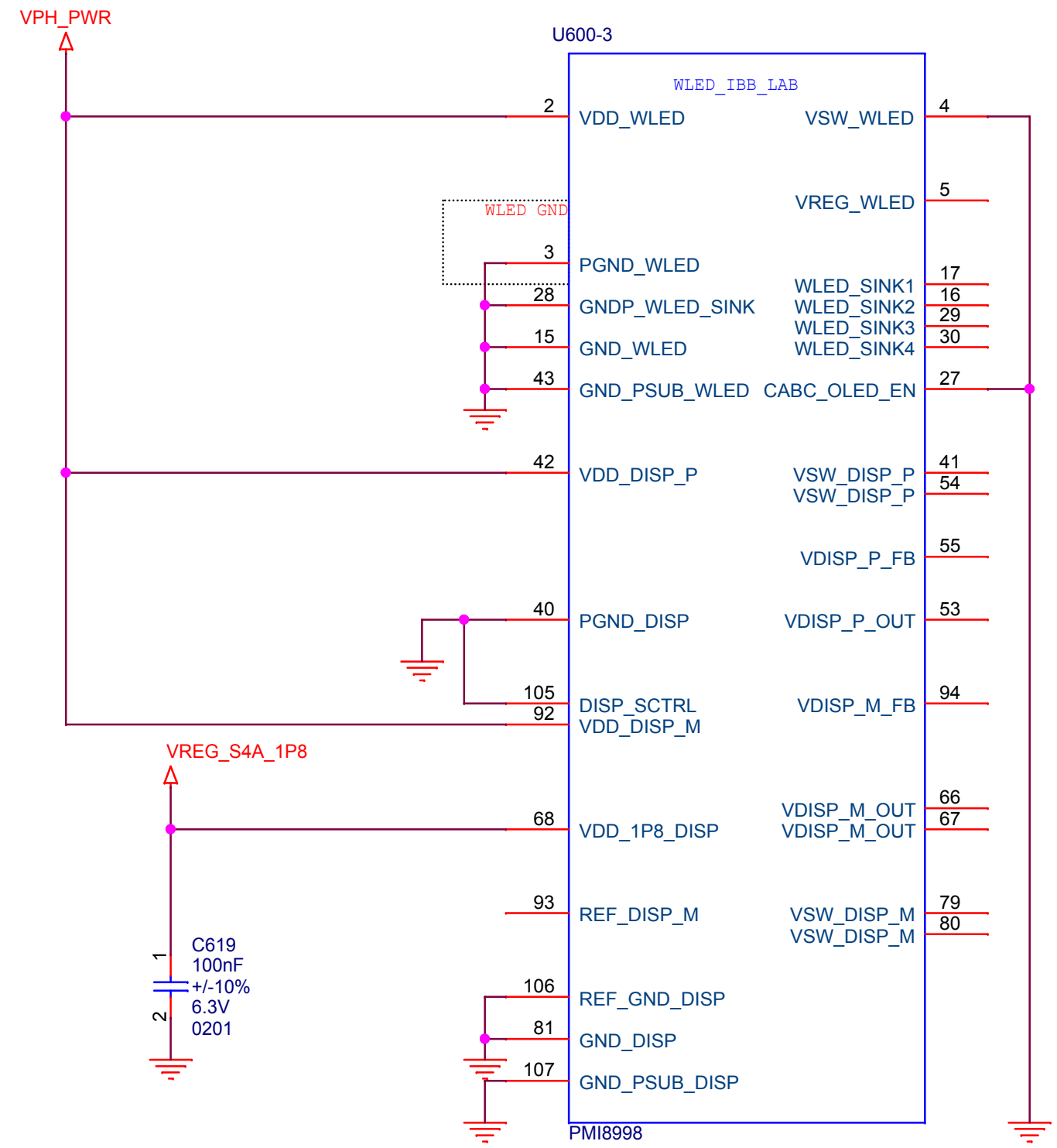

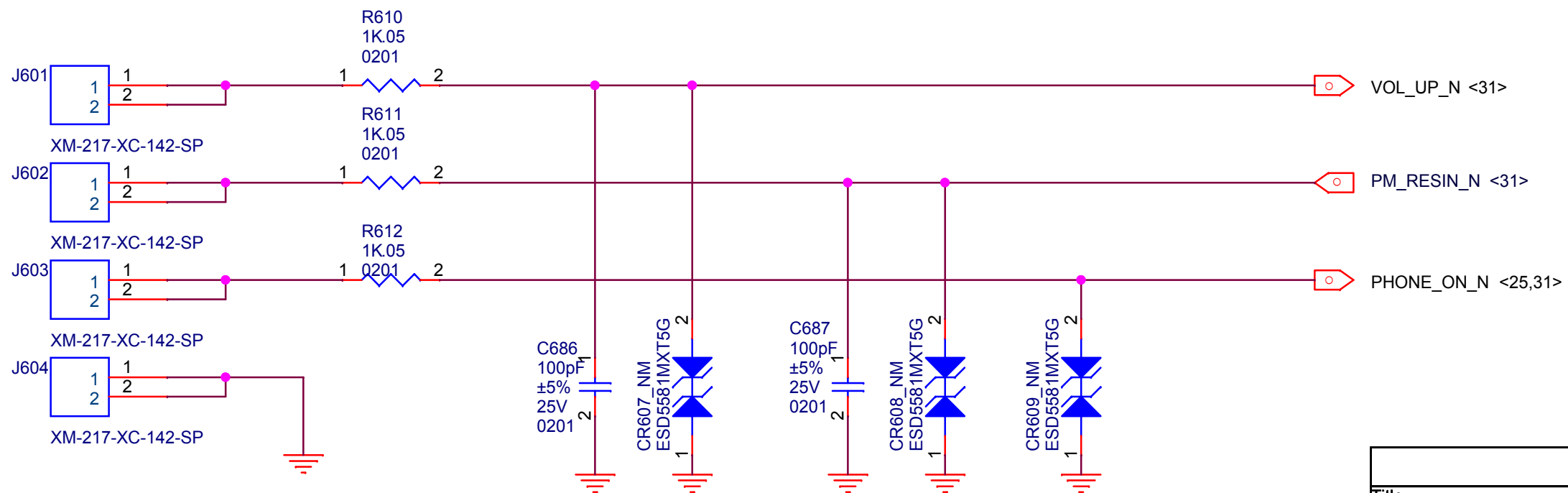
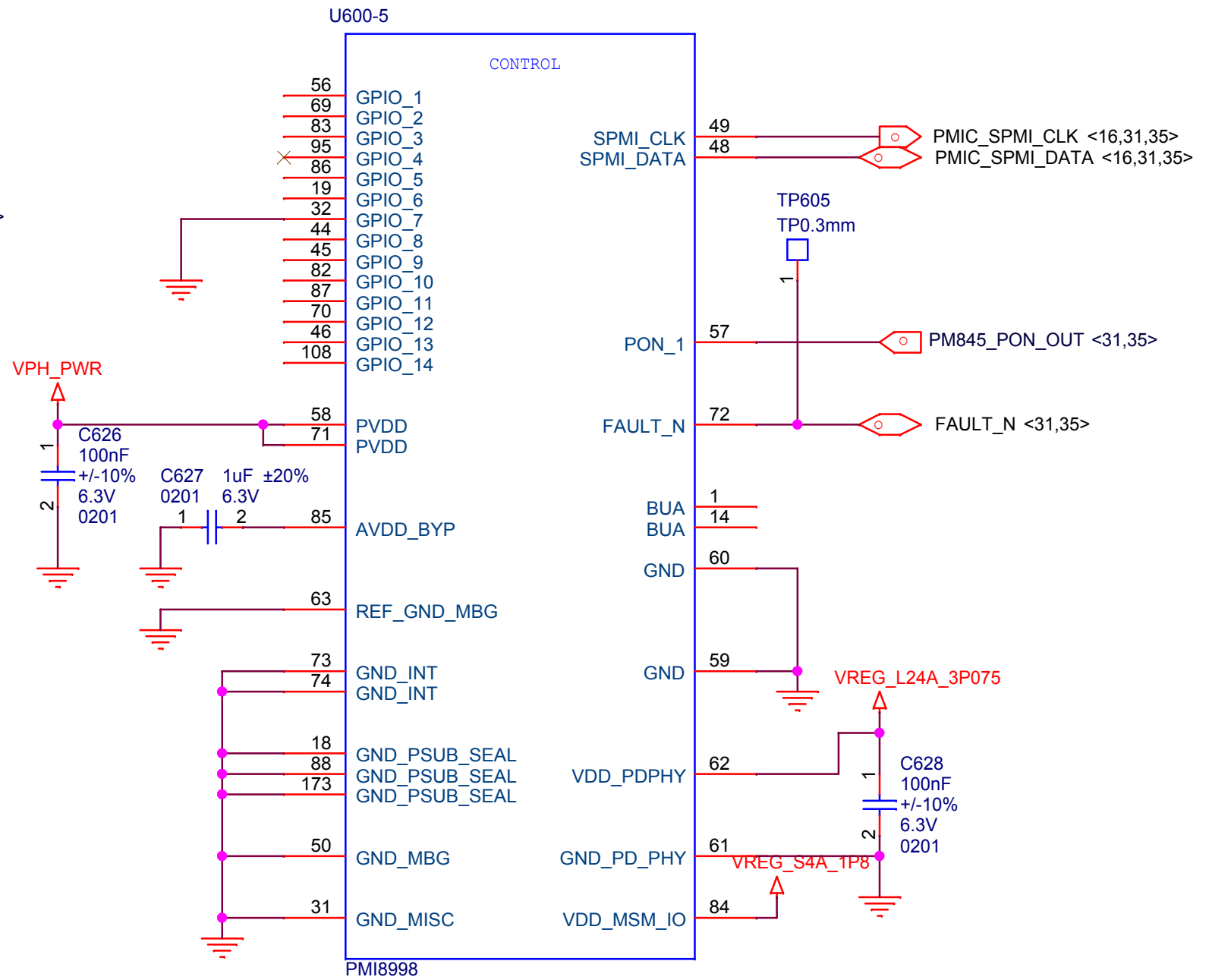
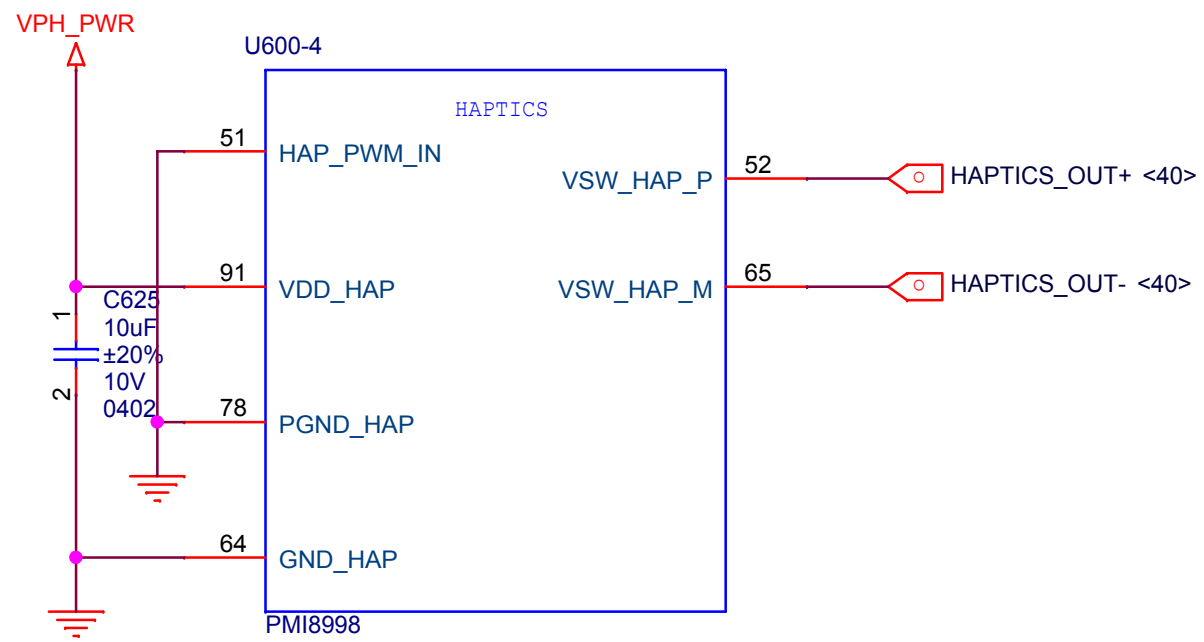

Title		E8		
Size	Document Number	PMI8998 WLED IBB LAB		
A4				P0
Date:	Friday, March 23, 2018	Sheet	27 of 44	



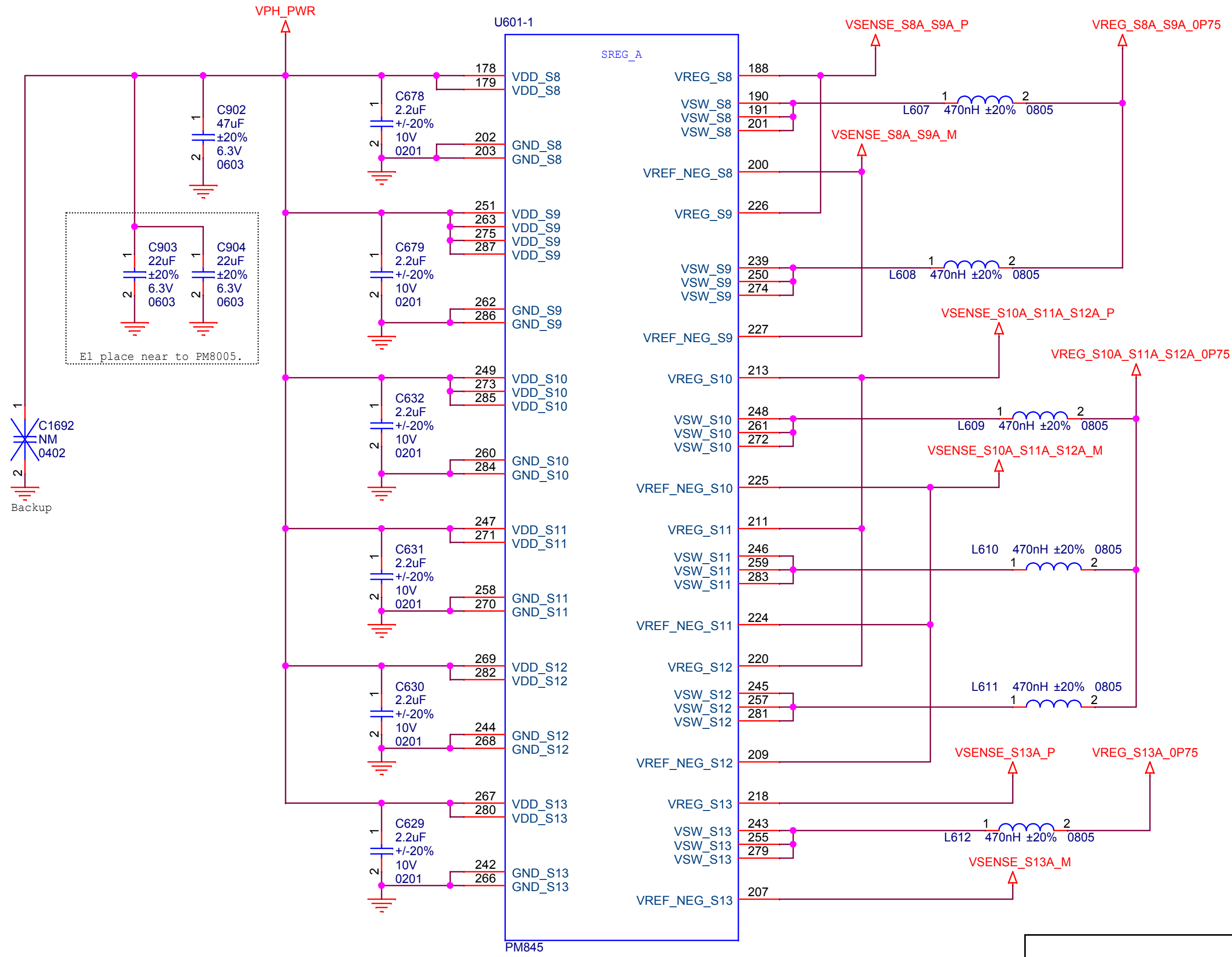

Title		E8	
Size	Document Number	PMI8998 HAPTICS&SIDEKEY	
A4	Rev	P0	
Date:	Friday, March 23, 2018	Sheet	28 of 44

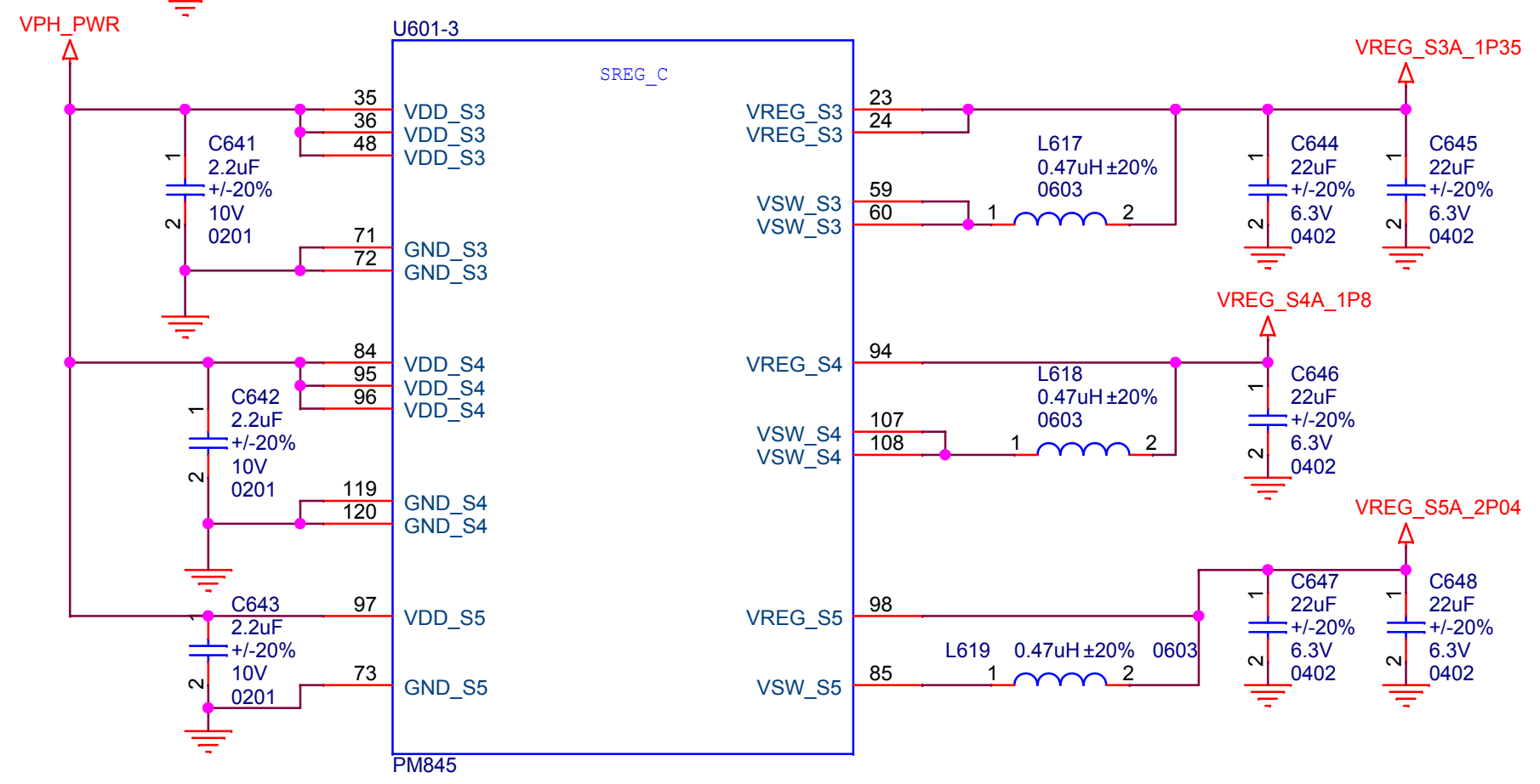
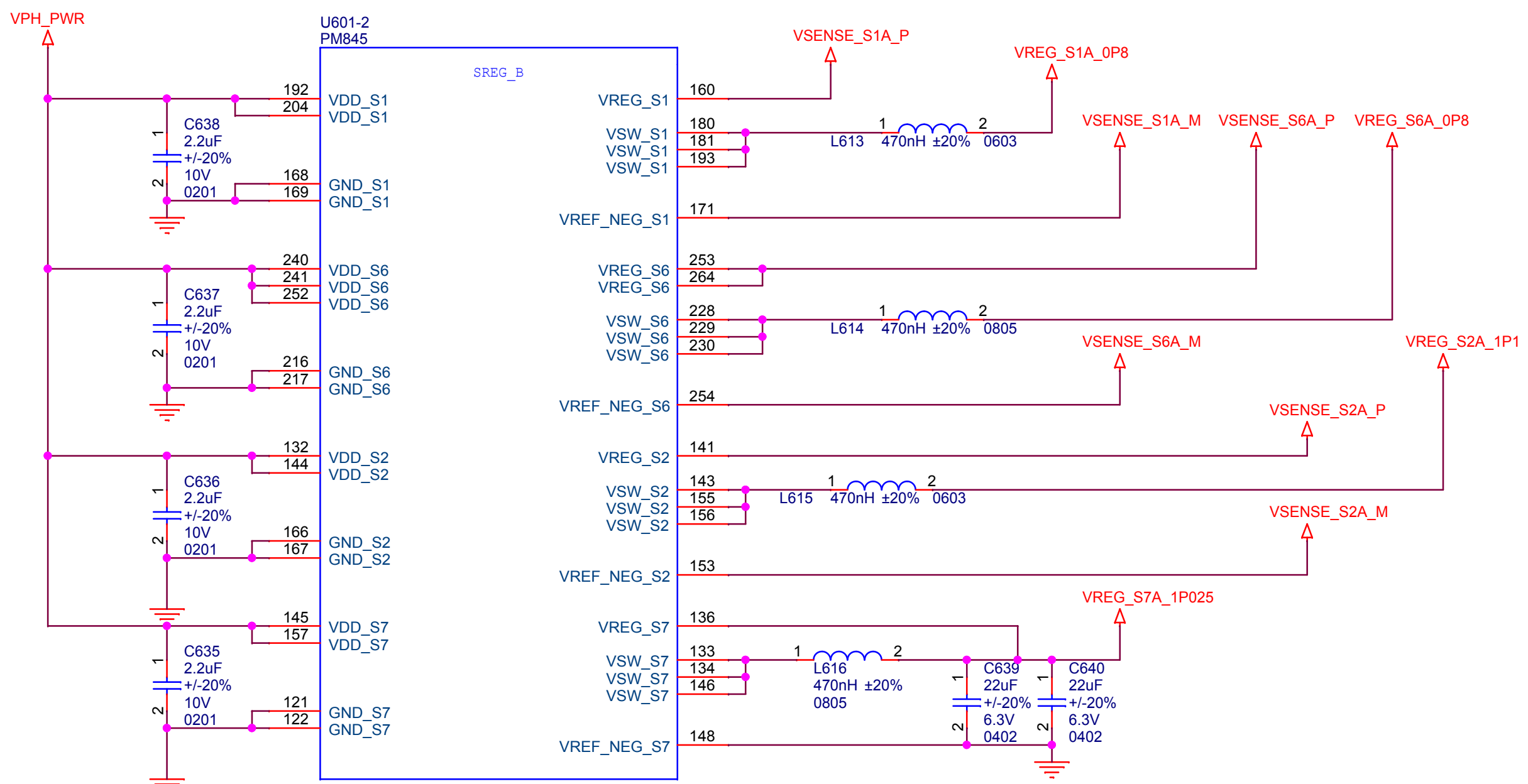

E1 place near to PM8005.

Title		E8		
Size	A4	Document Number	PM845 SREG A	
Date:	Friday, March 23, 2018	Sheet	29 of 44	Rev
				P0



Title		E8			
Size	A4	Document Number	PM845 SREG B&C		Rev
Date:	Friday, March 23, 2018		Sheet	30	of 44

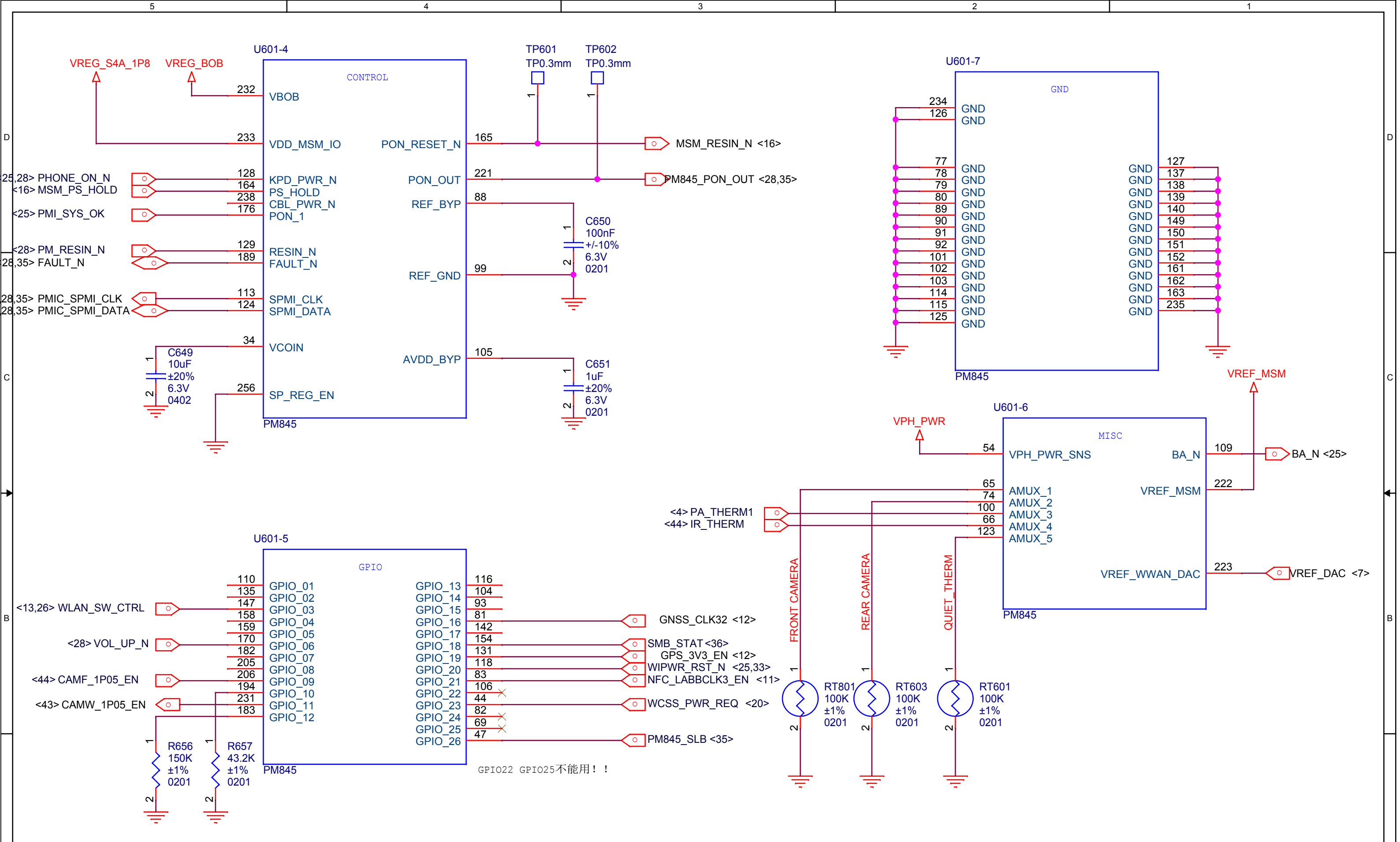

GPIO22 GPIO25不能用!!



Title		E8			
Size	A4	Document Number	PM845 CONTROL&GPIO&MICS		
Date:	Friday, March 23, 2018	Sheet	31 of 44	Rev	P0

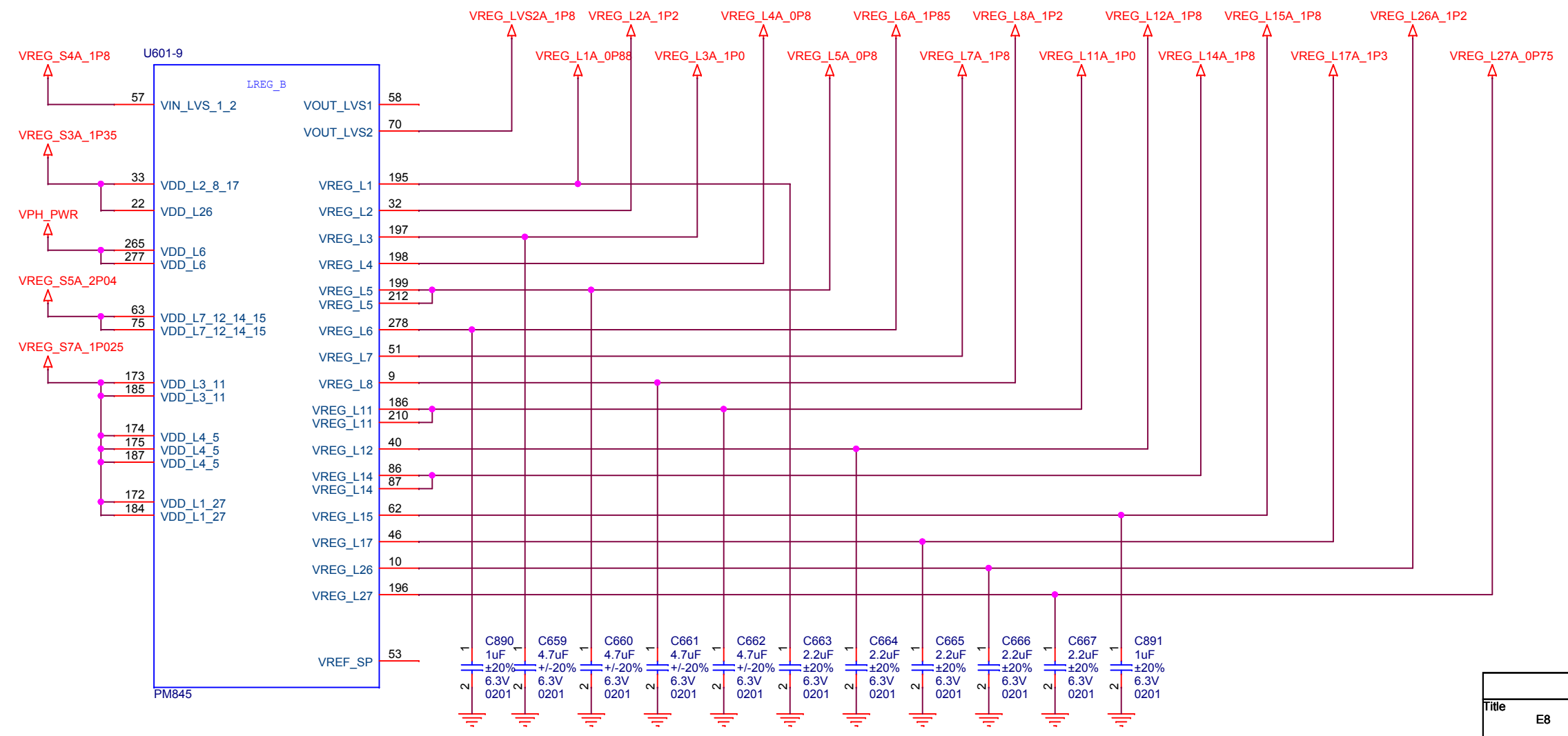
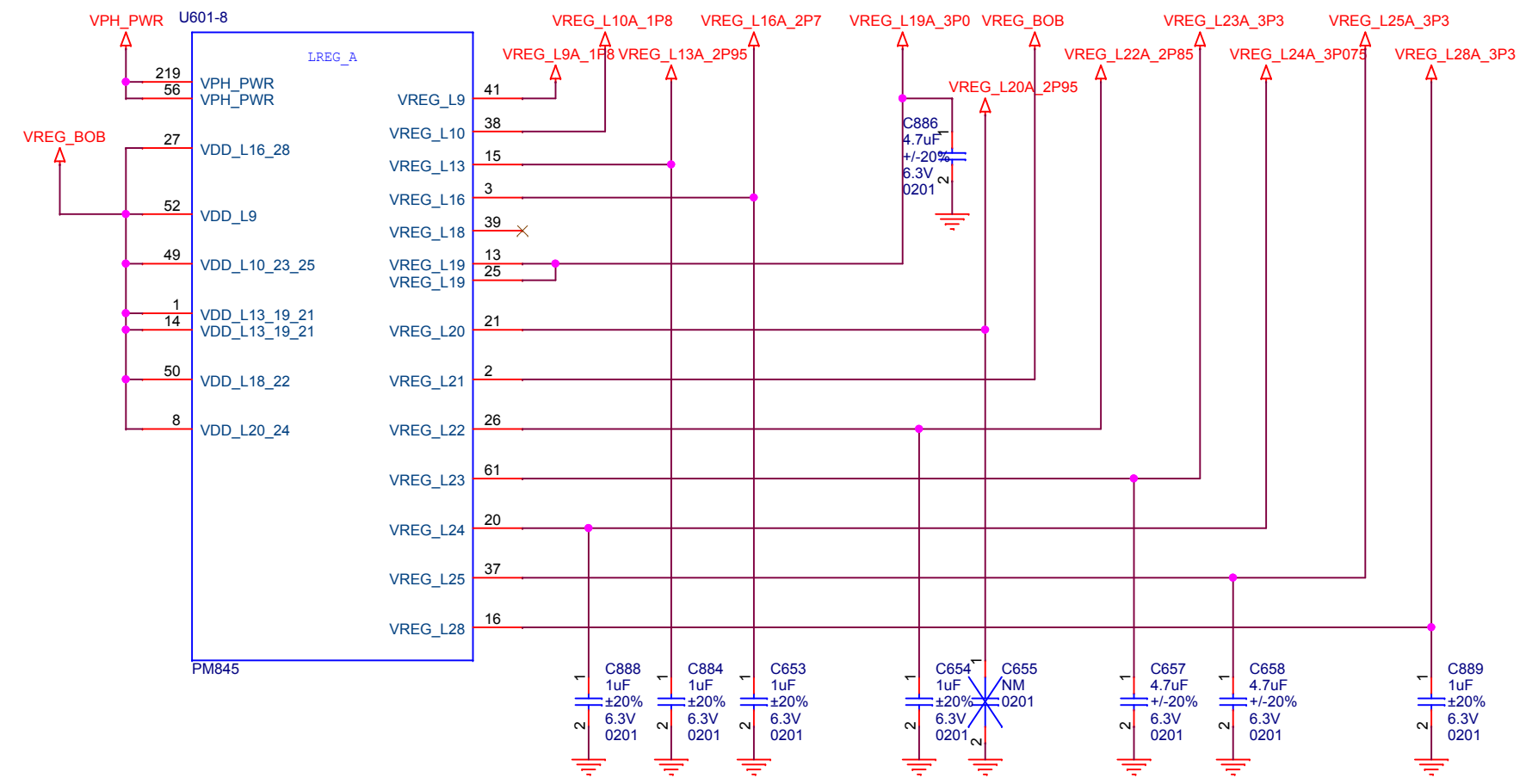

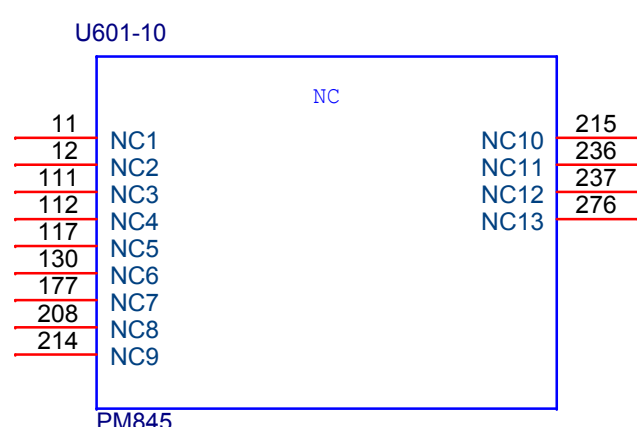
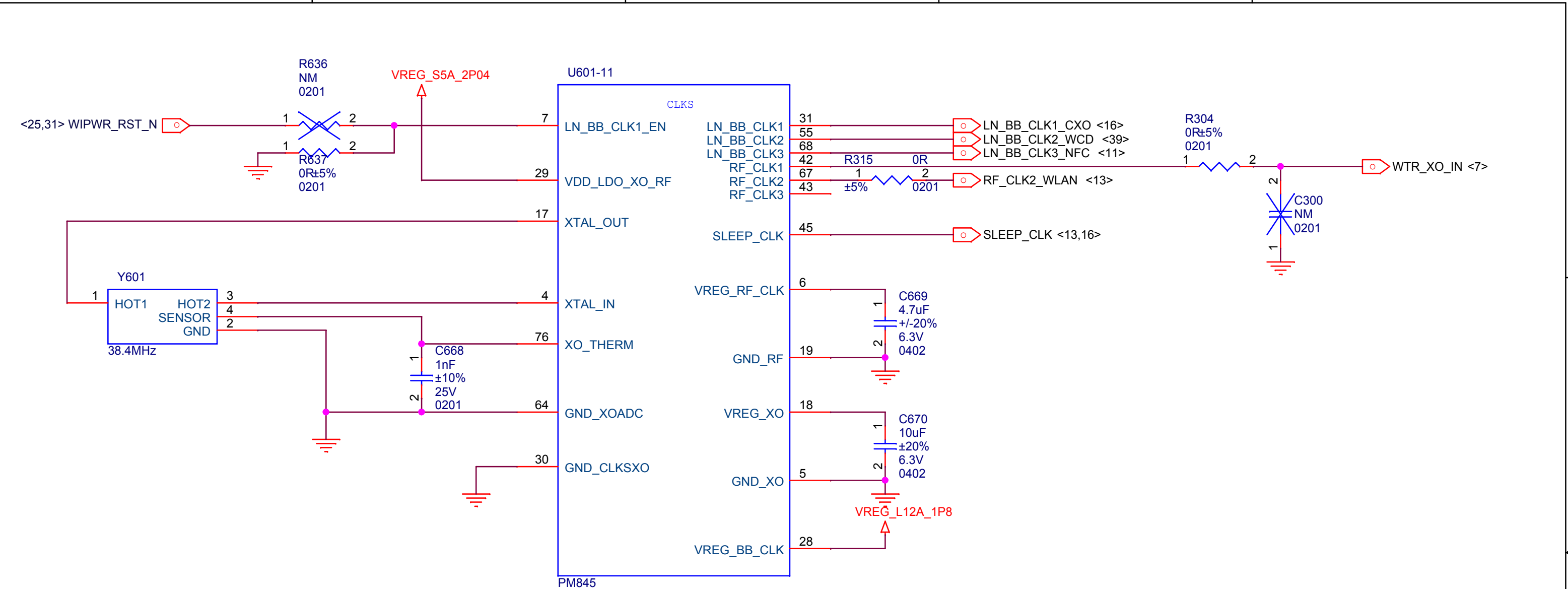

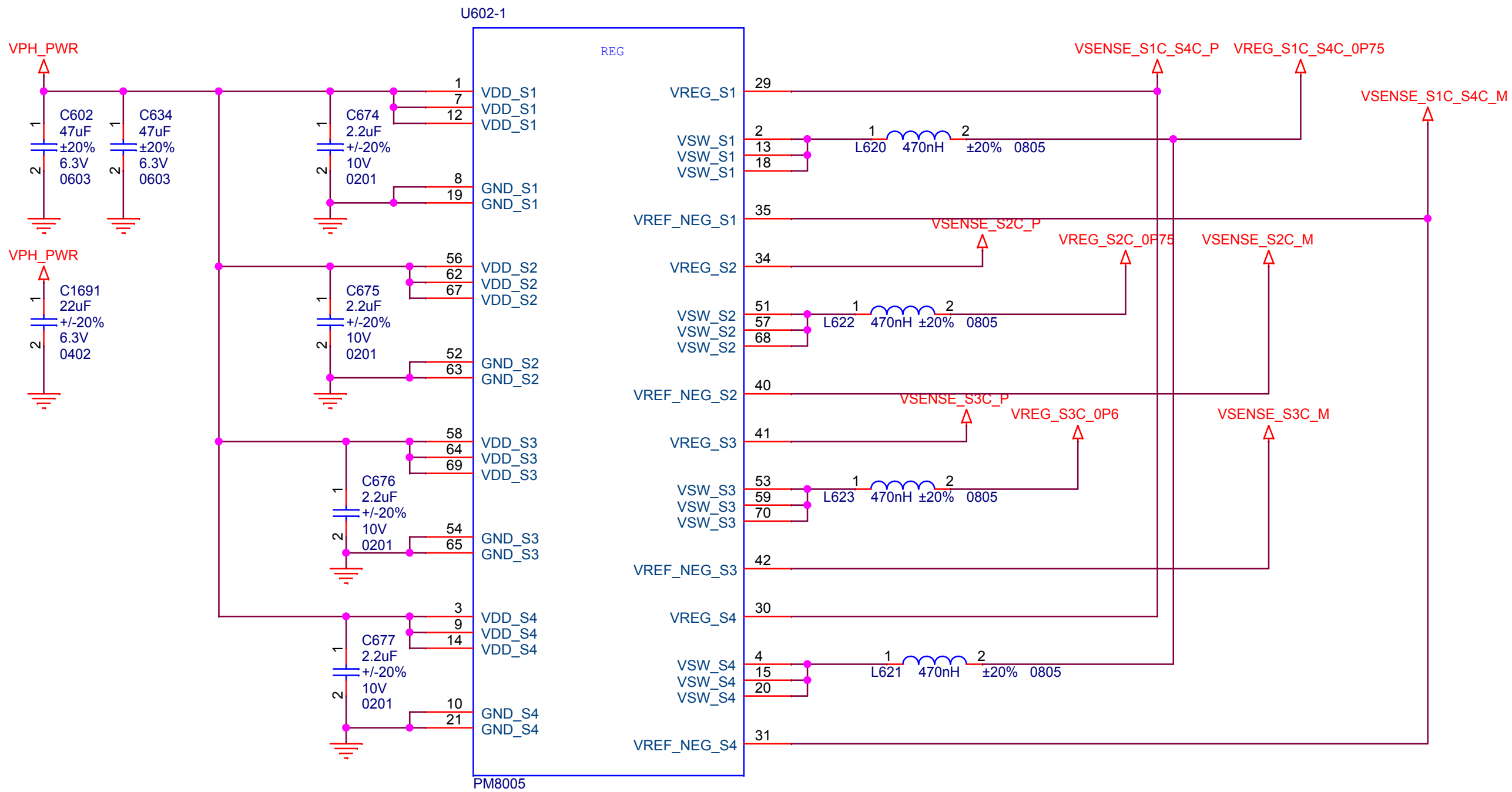

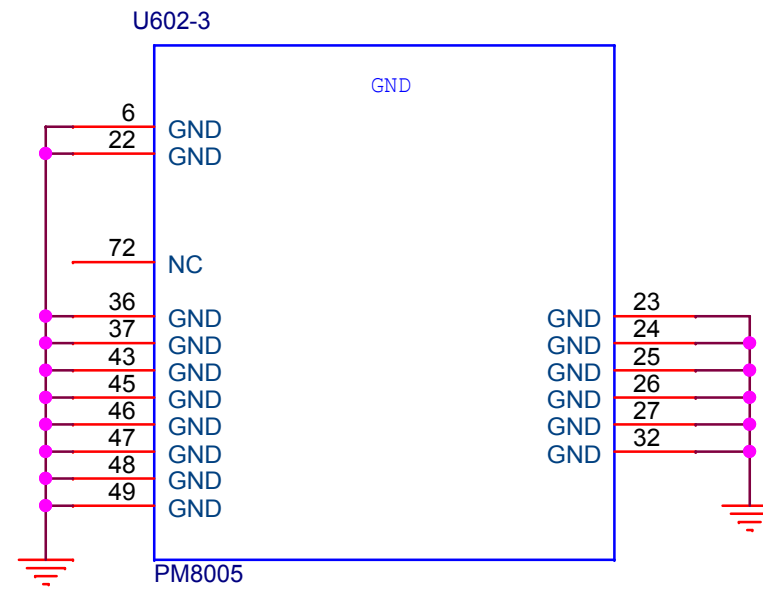
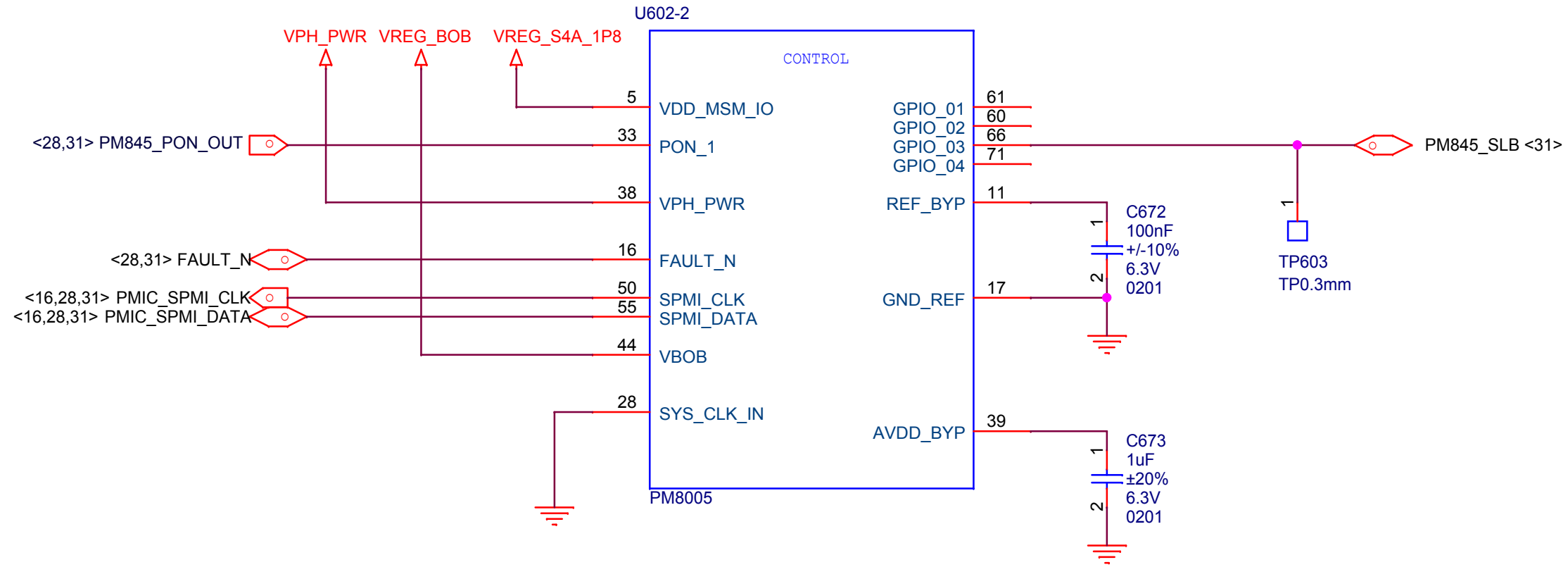

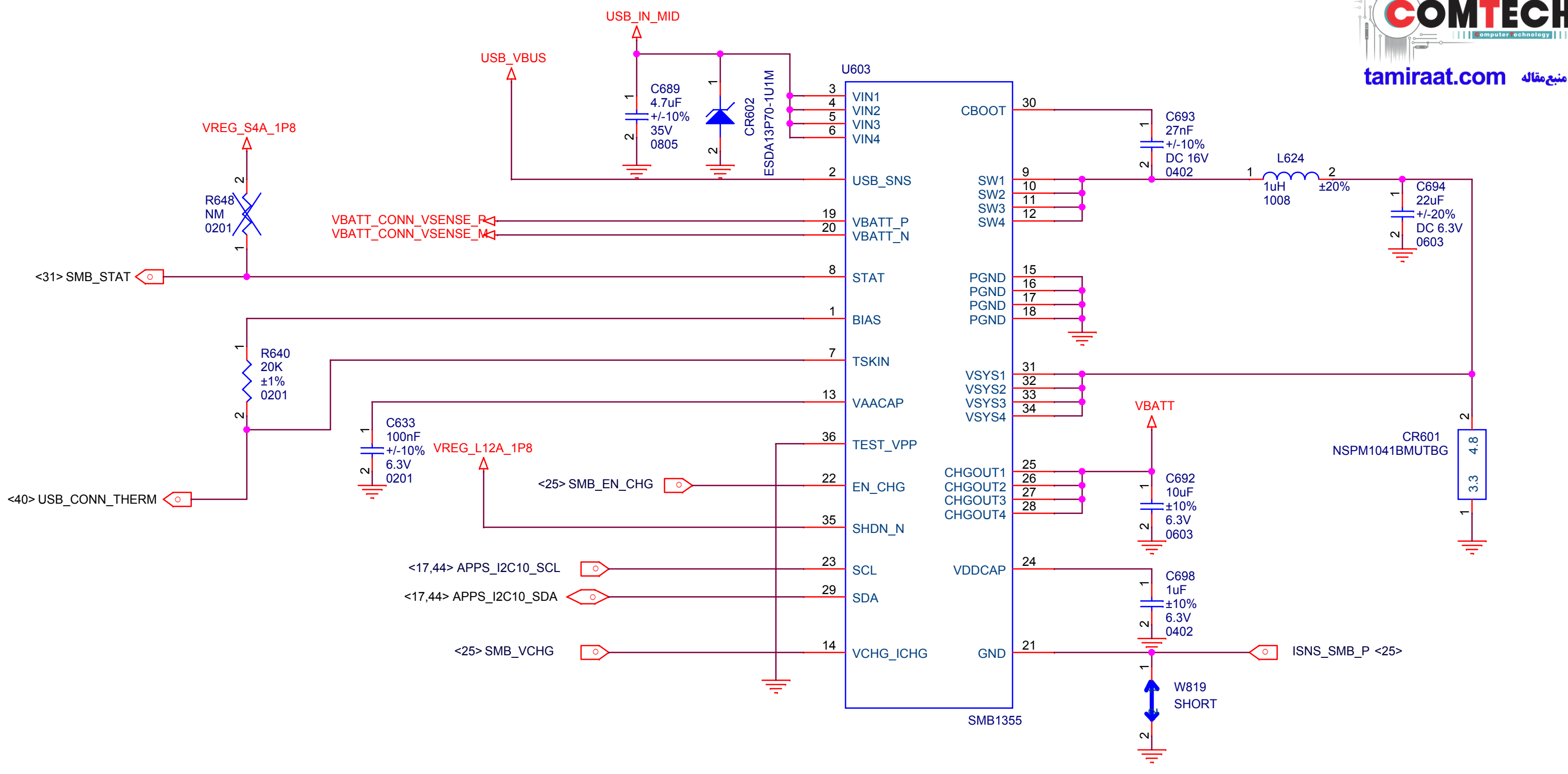

<16> UFS_RESET_N
 <16> UFS1_REF_CLK
 <16> UFS1_L0_TX_P
 <16> UFS1_L0_TX_M
 <16> UFS1_L0_RX_M
 <16> UFS1_L0_RX_P
 <16> UFS1_L1_TX_P
 <16> UFS1_L1_TX_M
 <16> UFS1_L1_RX_M
 <16> UFS1_L1_RX_P

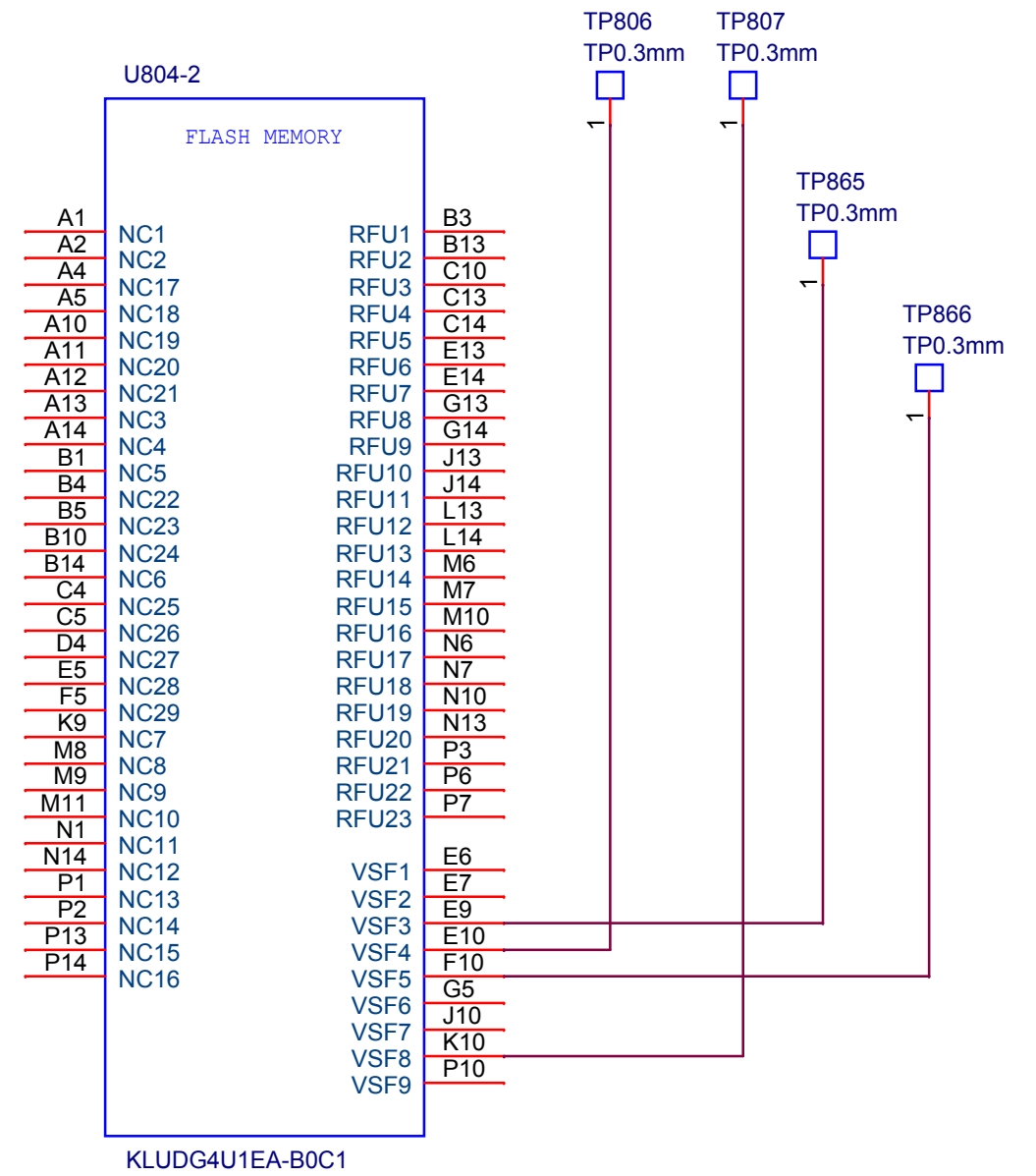
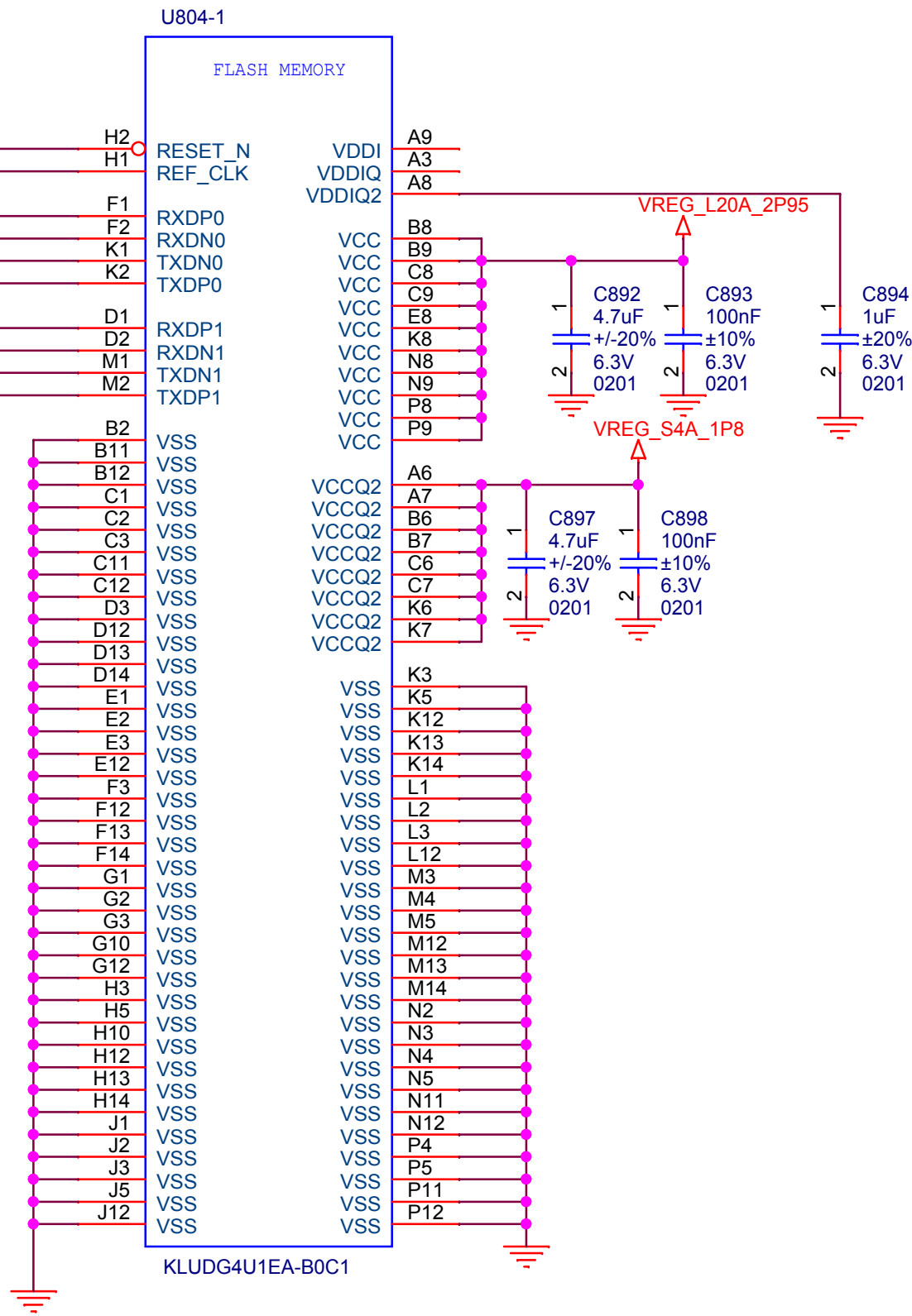

Speaker PA

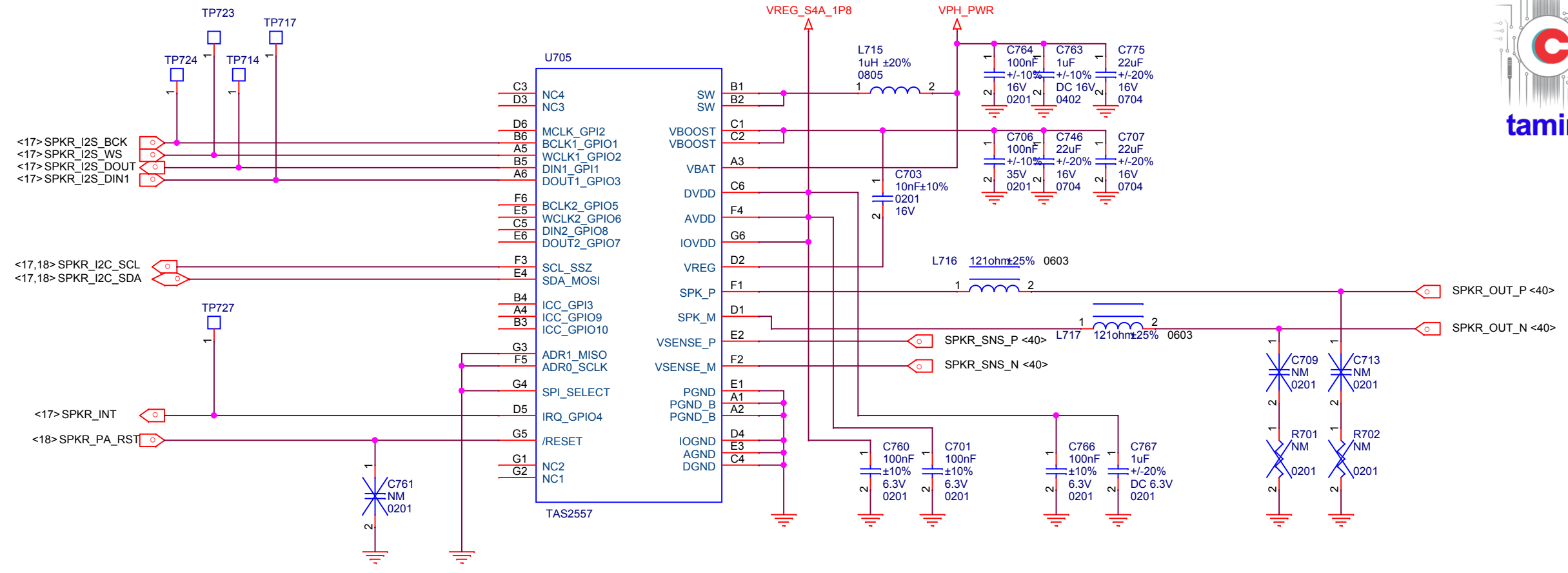

AUX Mic

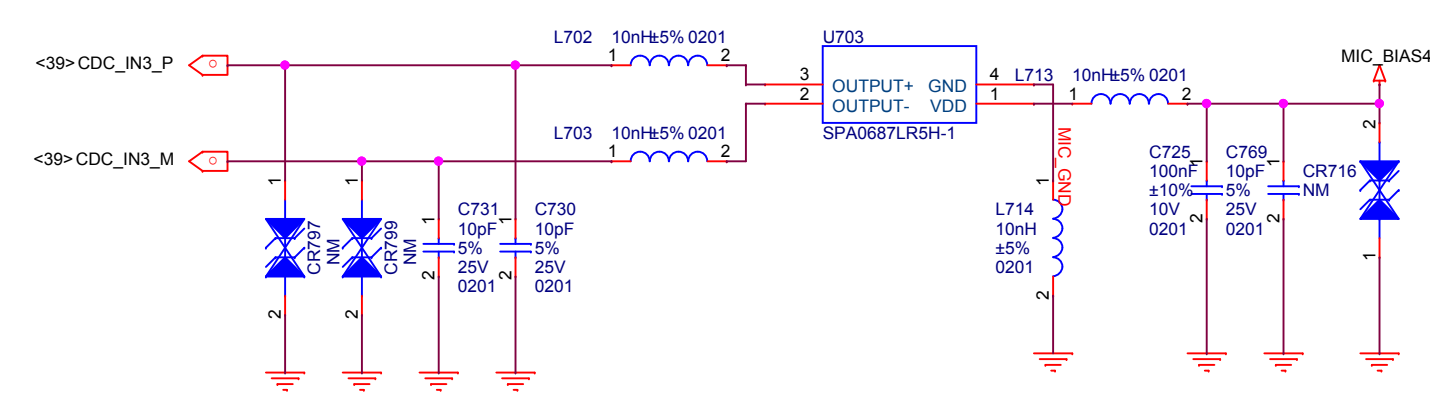

Receiver

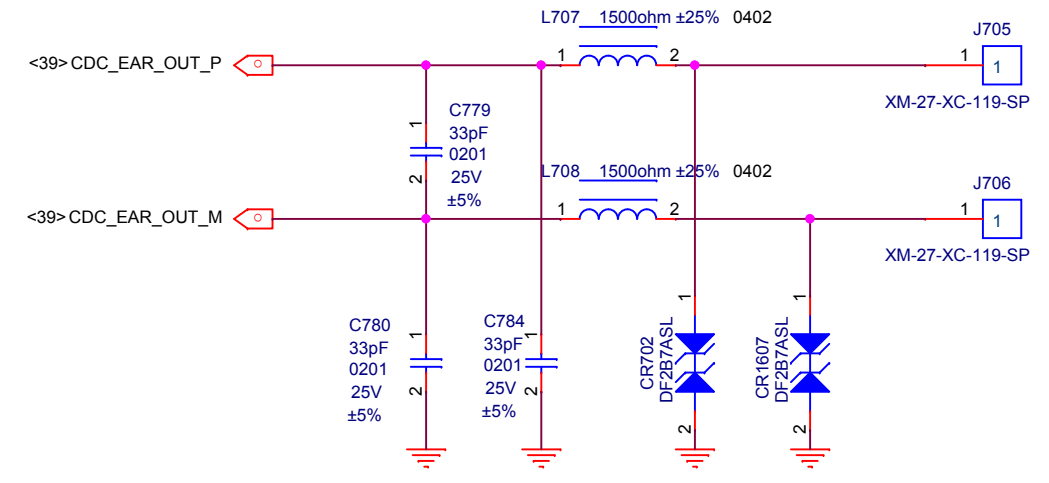

HEADSET

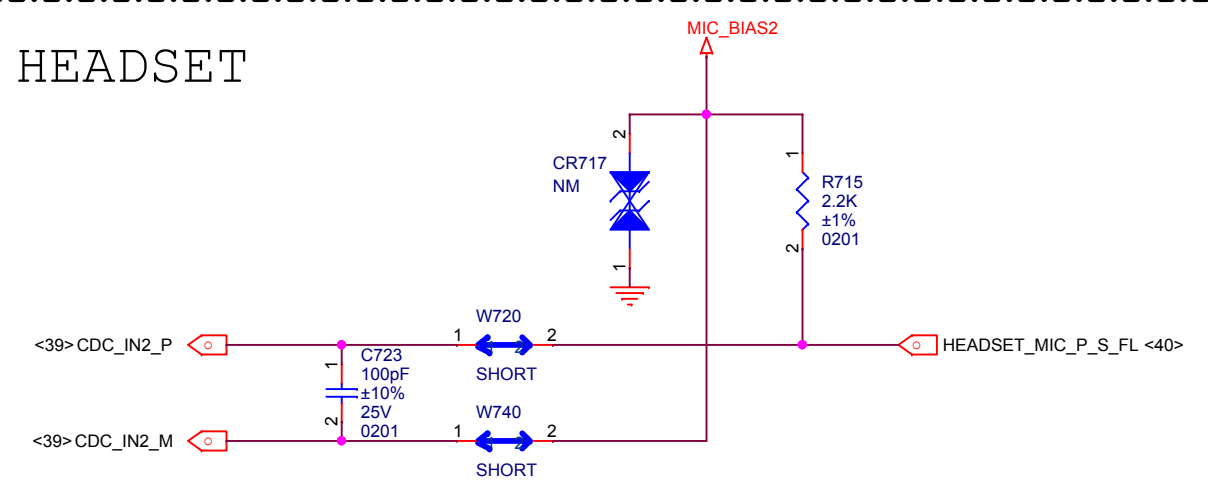

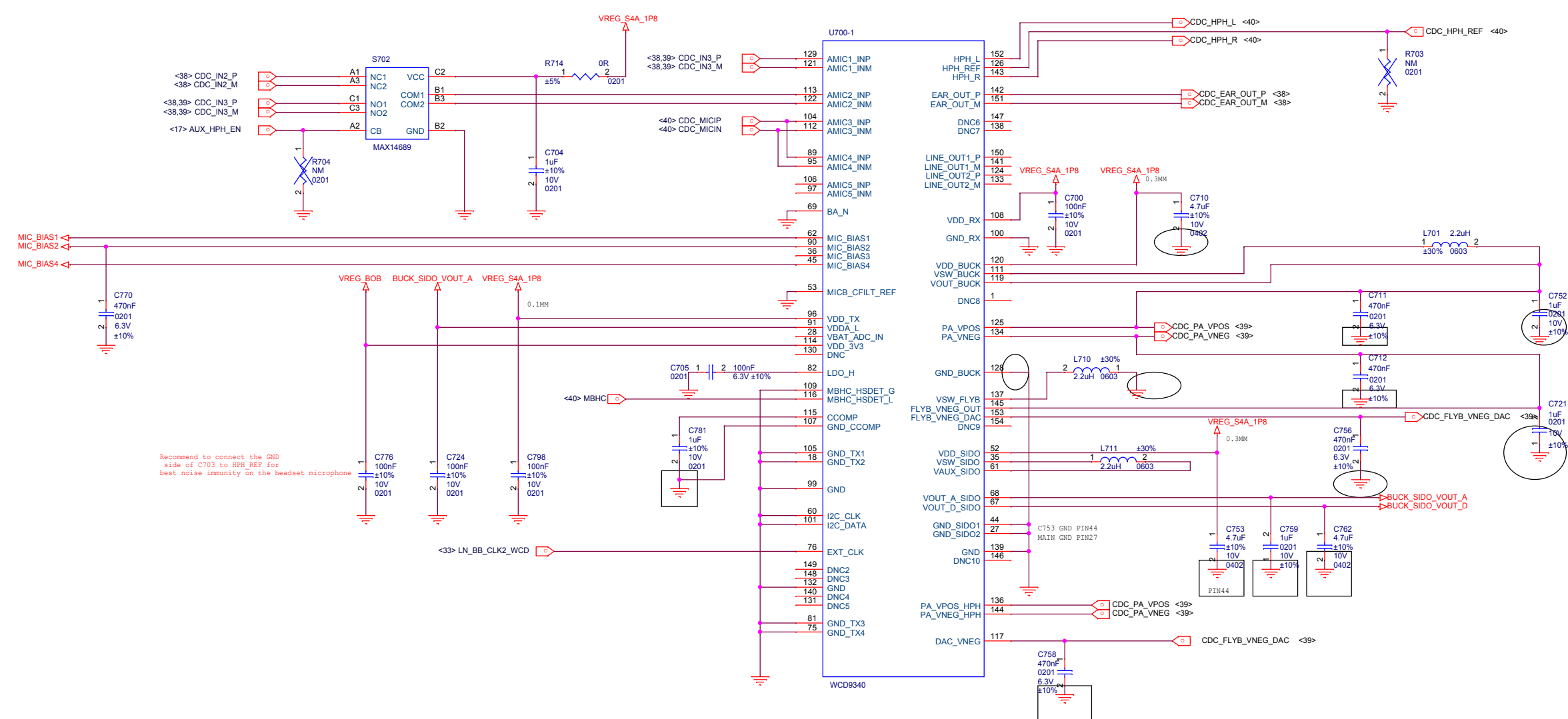

Recommend to connect the GND side of C703 to HPH_SSP for best noise immunity on the headset microphone

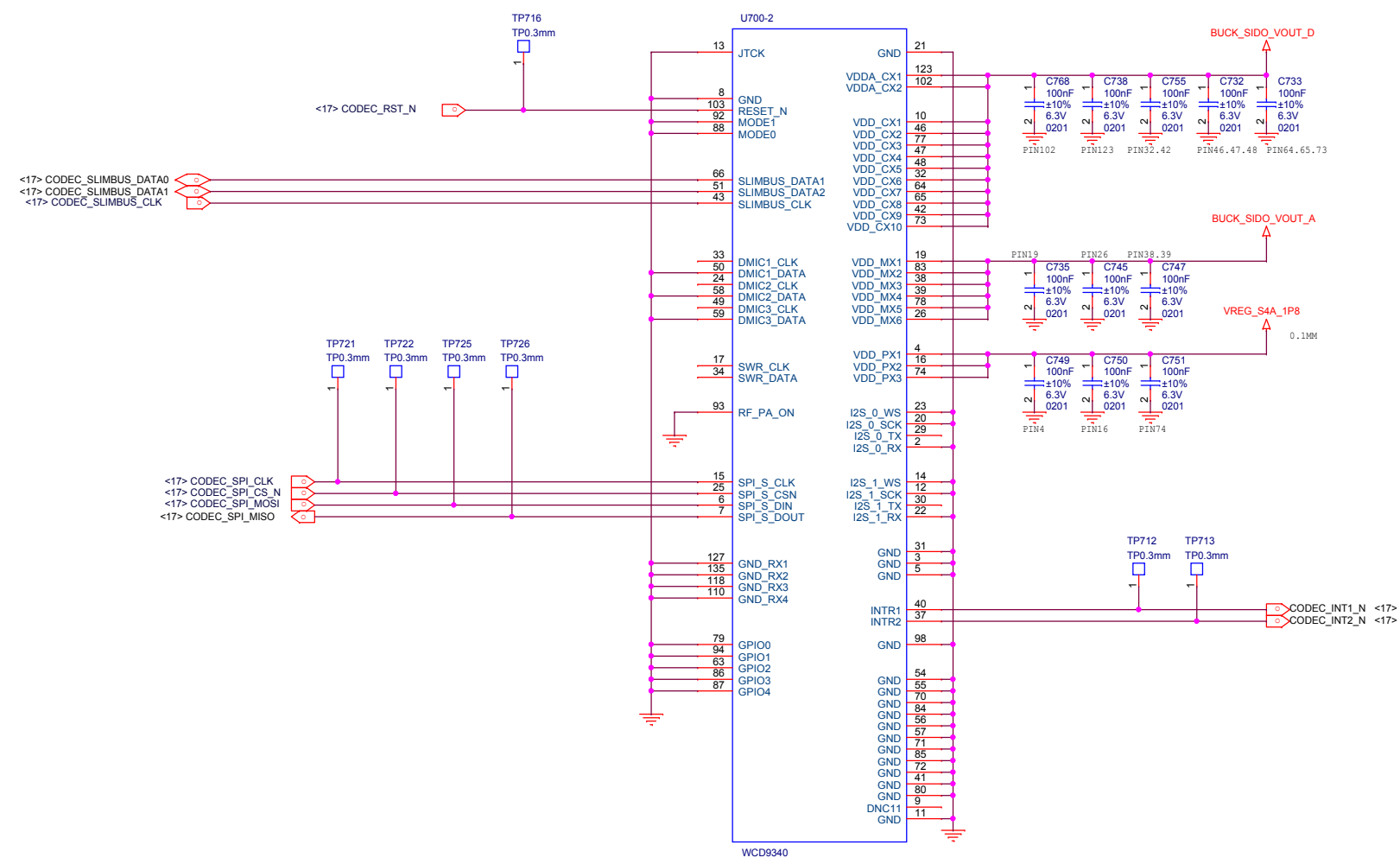

LCD PWR

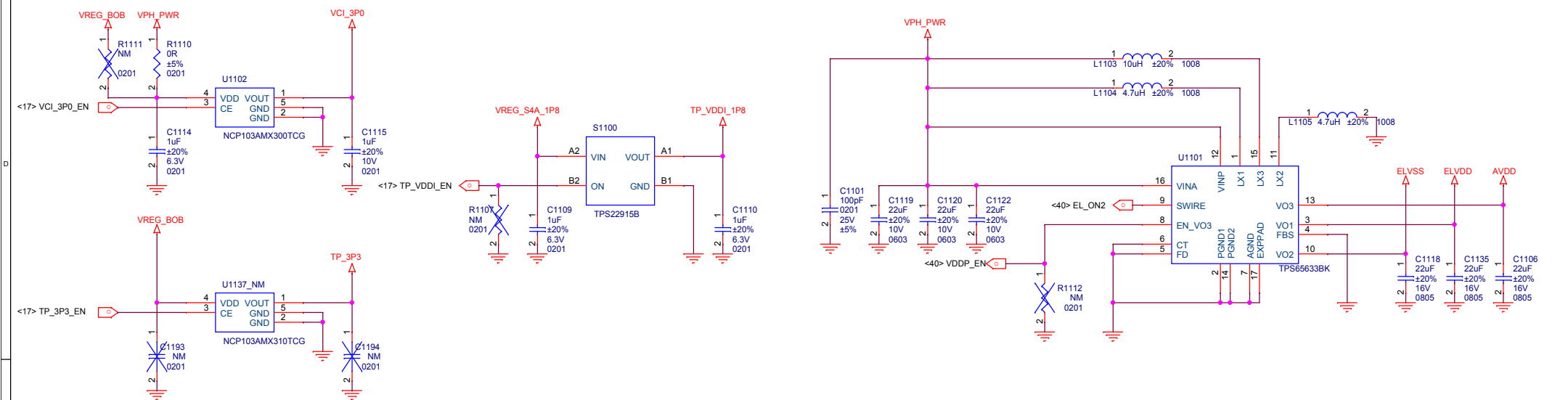

LCD Filter

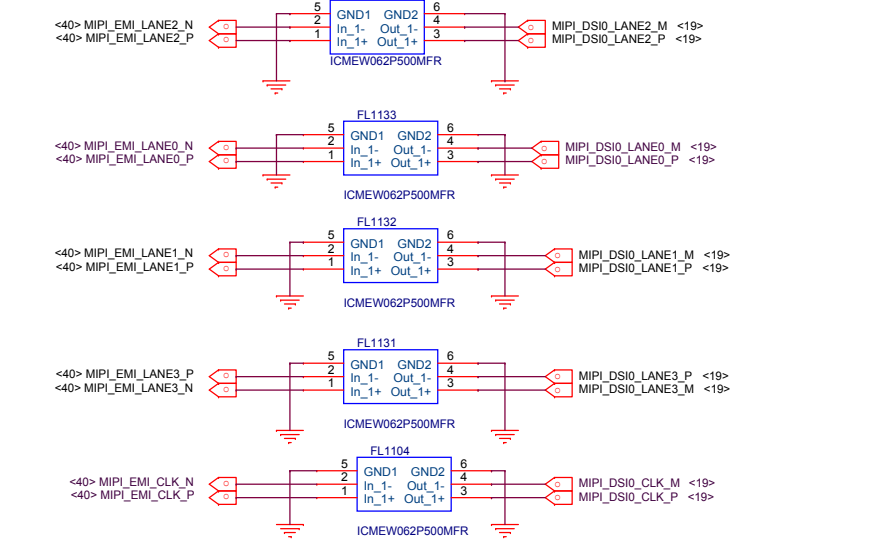

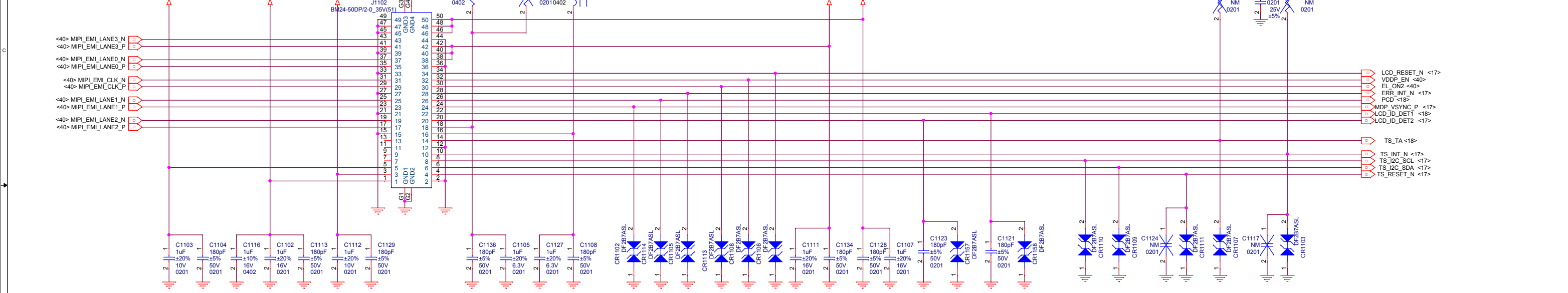

LCD Connector PIN MAP!!!

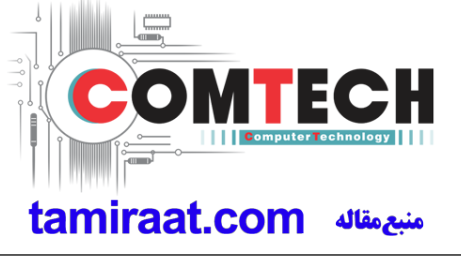
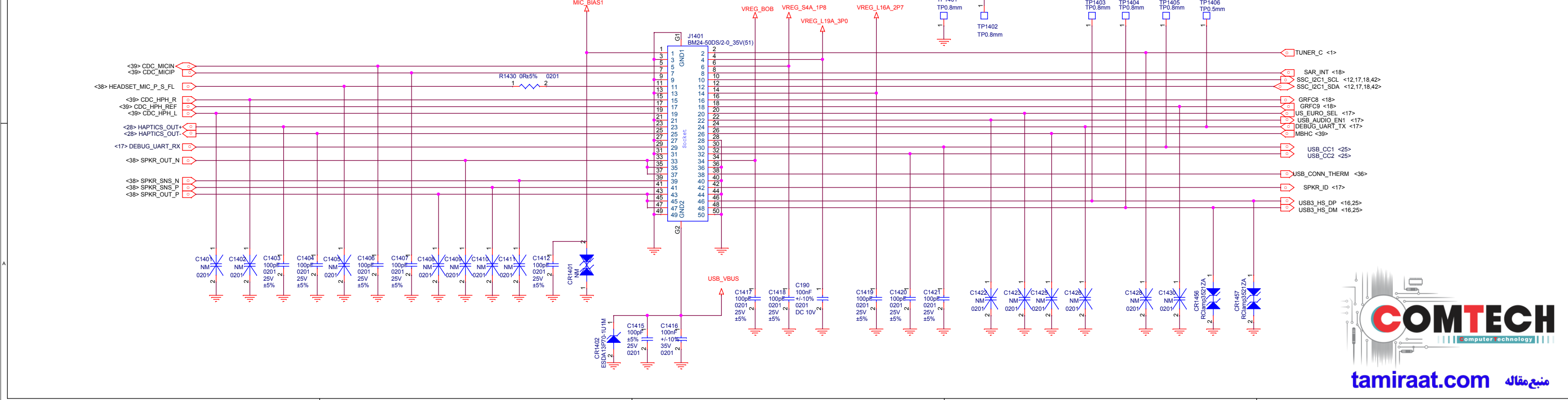

BTB Connector

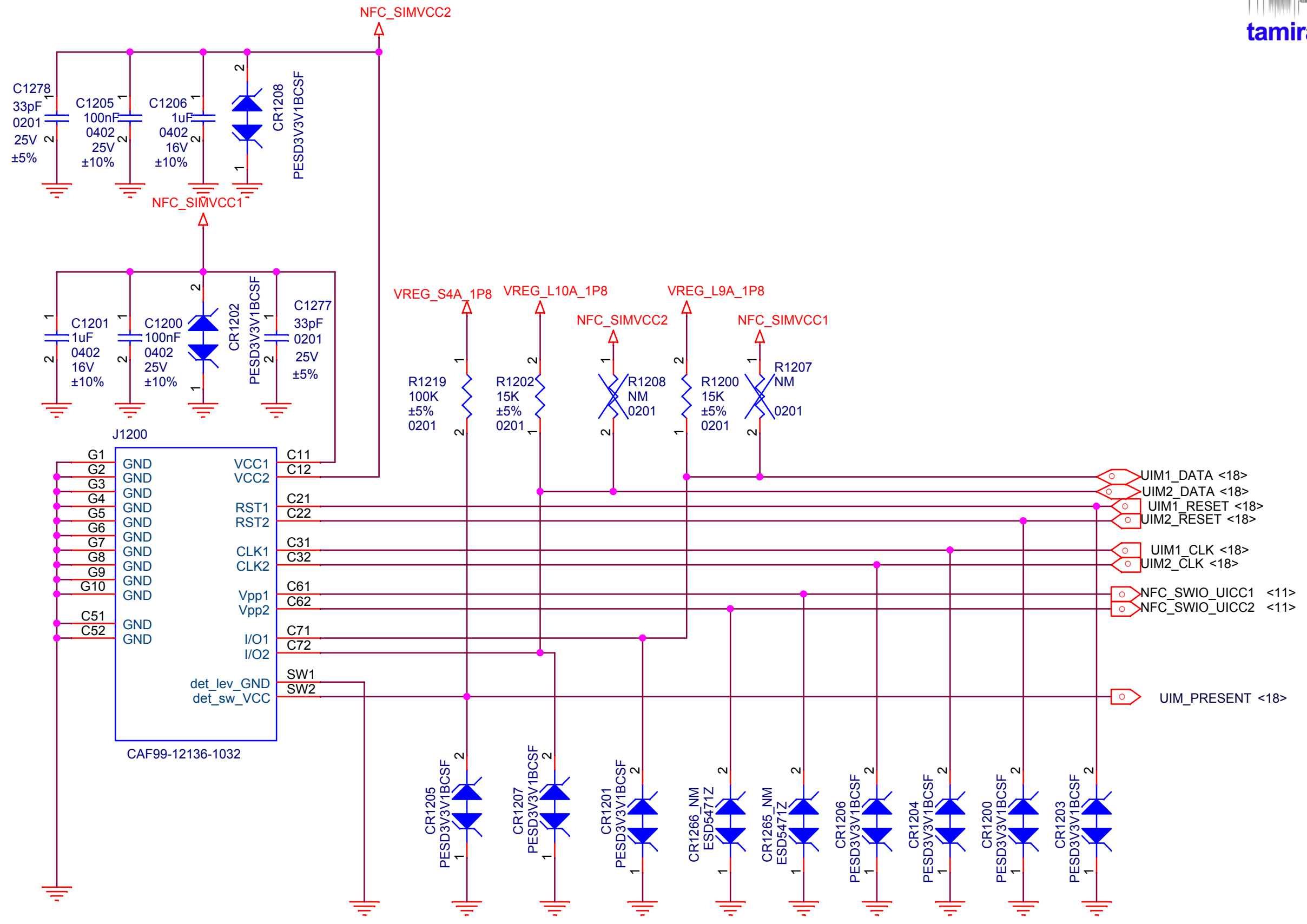



Title		
E8		
Size	Document Number	Rev
A4	SIM CONNECTOR	P0
Date:	Sheet	41 of 44

FINGERPRINT

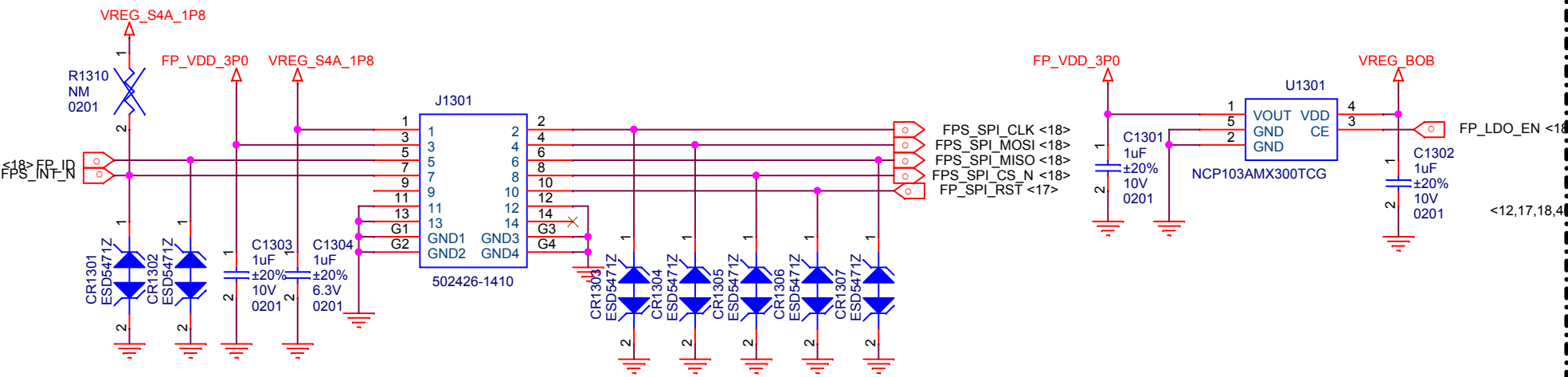

PRESSURE

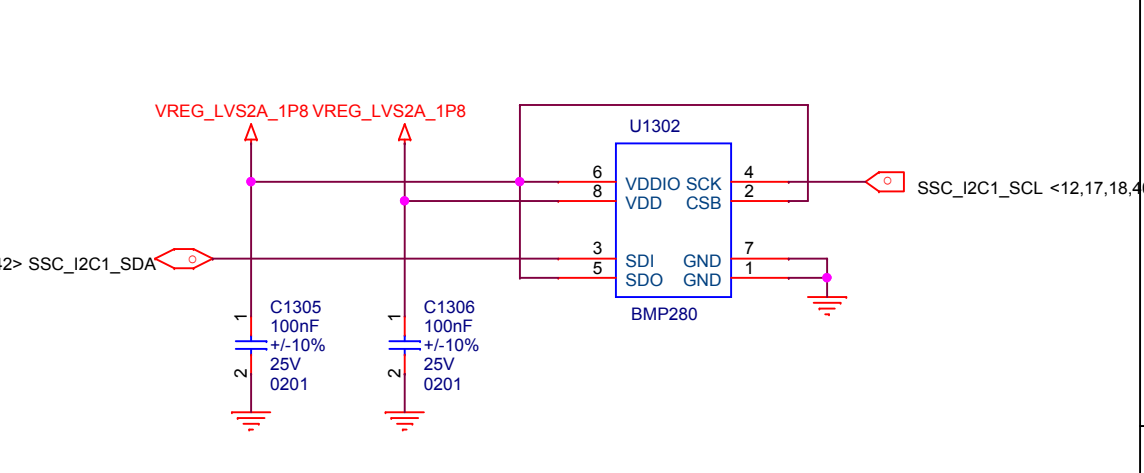

GYRO

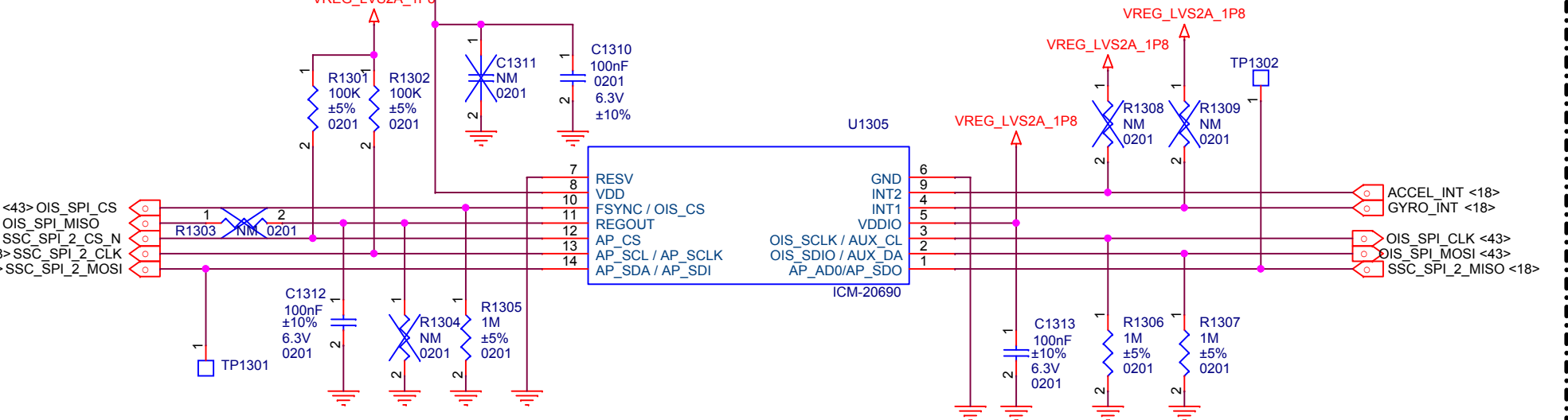

COMPASS

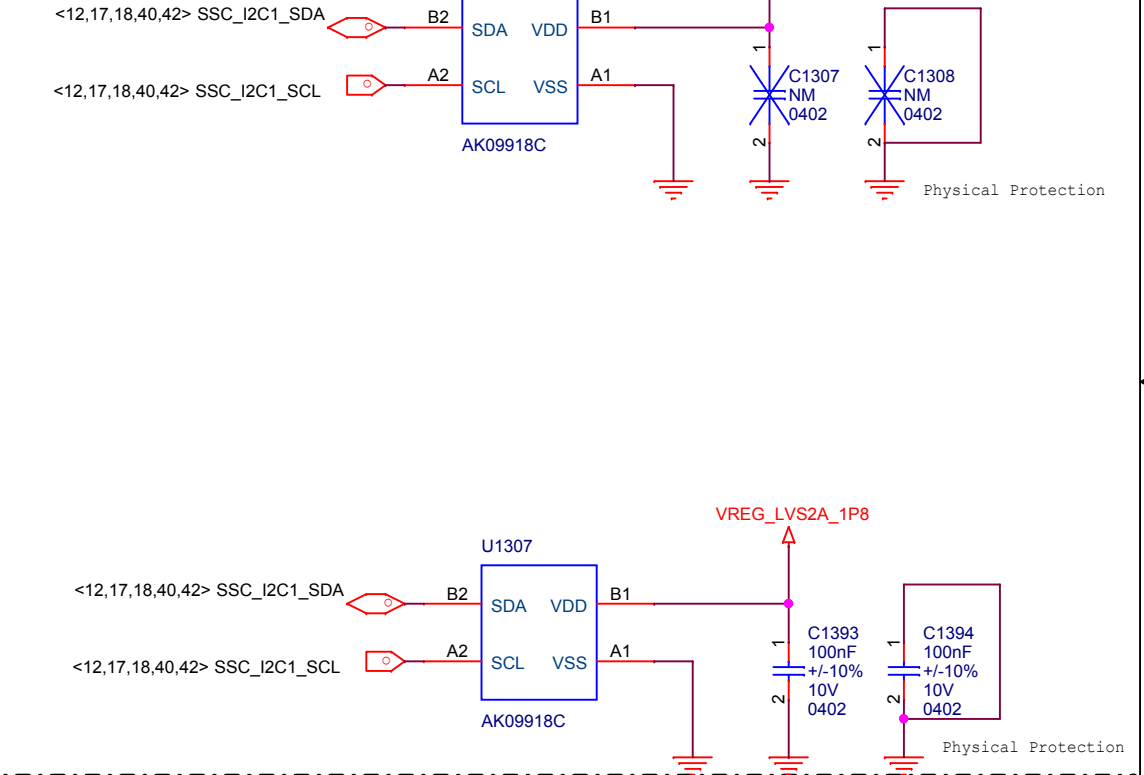

P-SENSOR

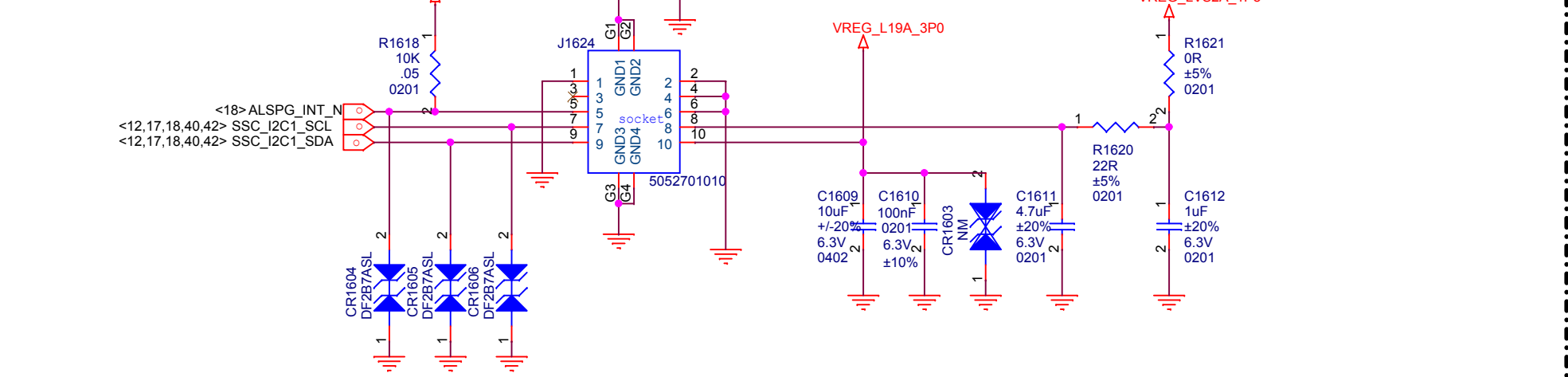

HALL

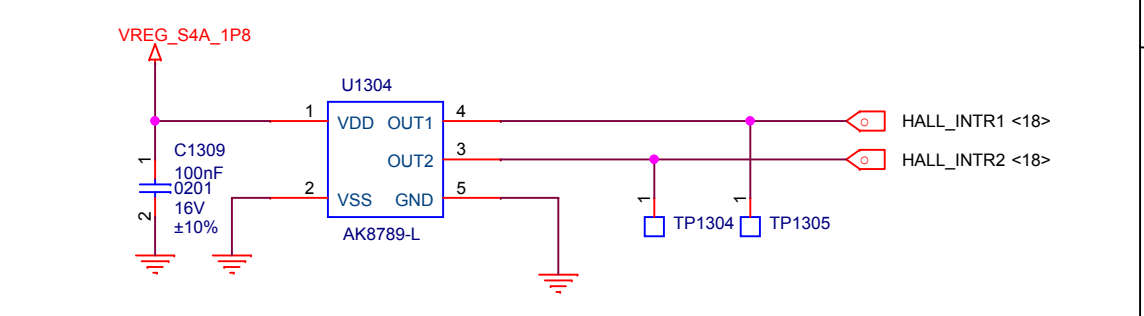

LDOs

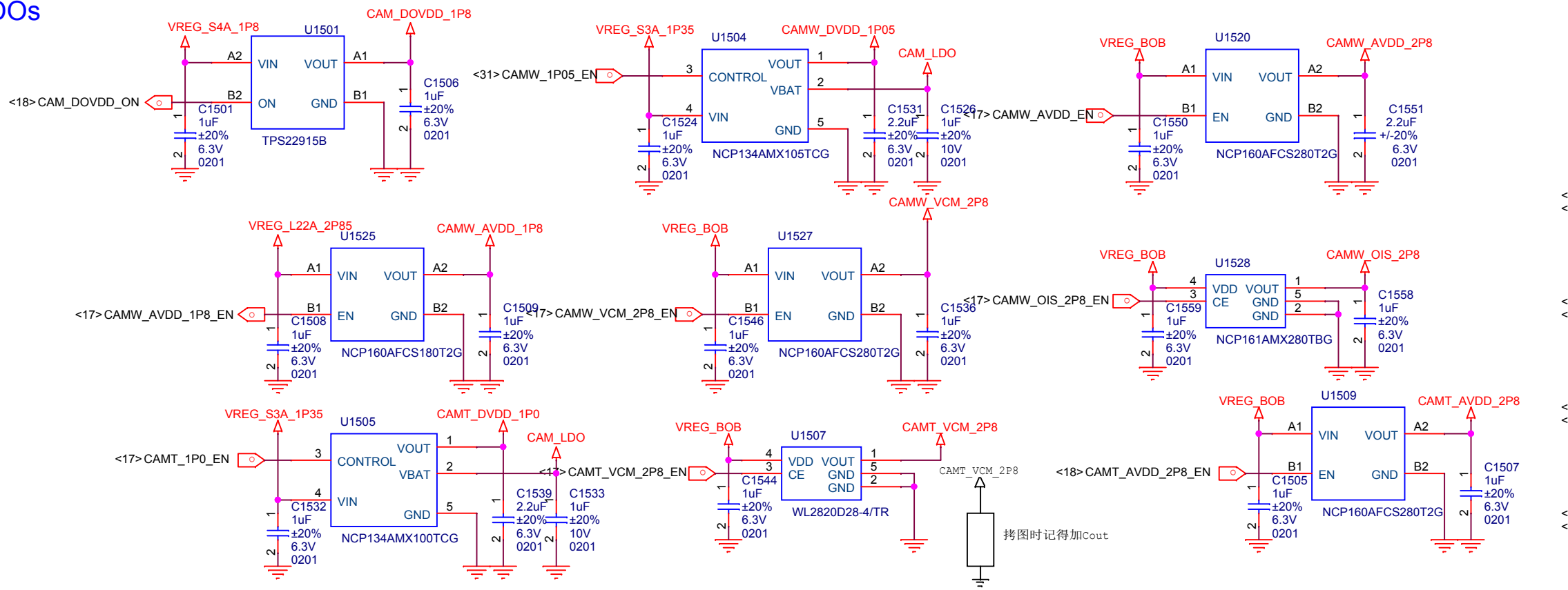

REAR EMI

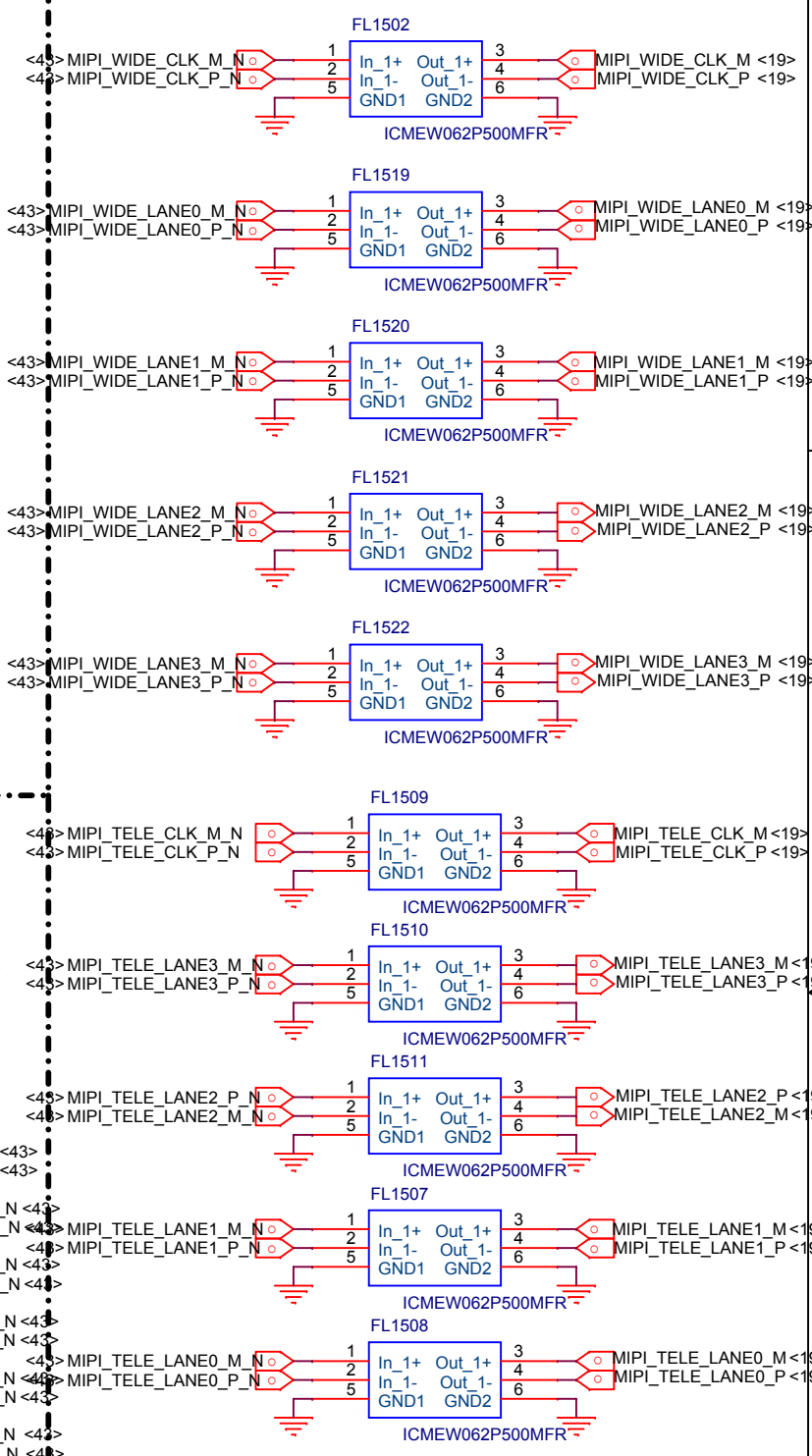

REAR CAMERA

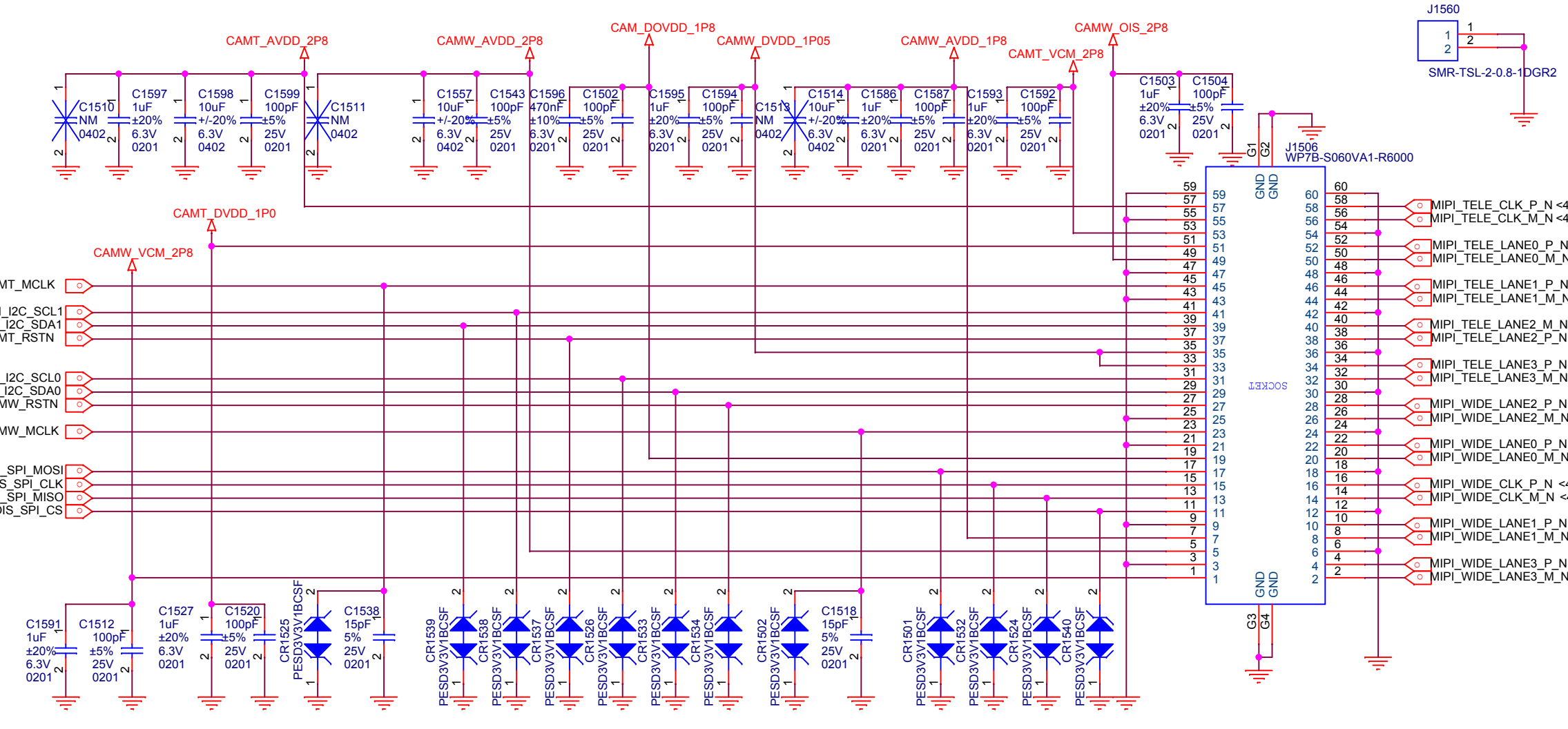

FLASH

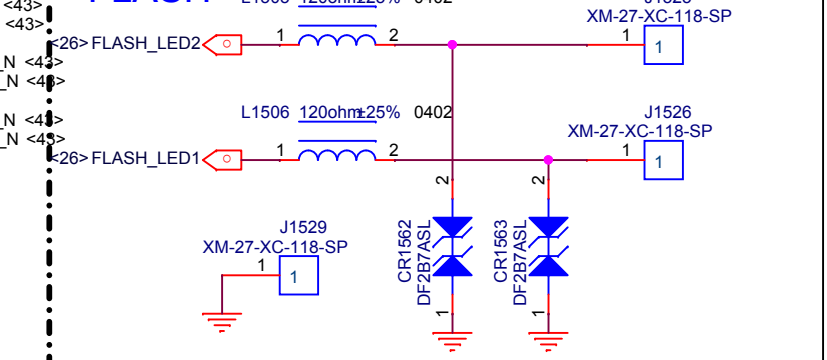

Title		E8	
Size	A3	Document Number	REAR CAMERA&FLASH
Date:		Rev	P0
		Sheet	43 of 44



LDOs

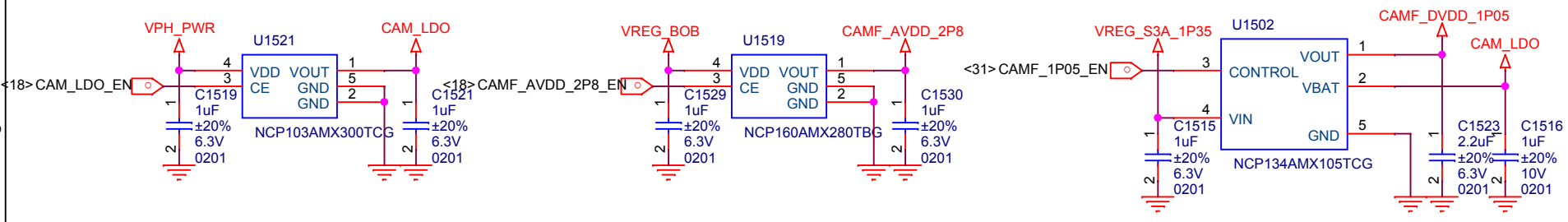

IR CAMERA

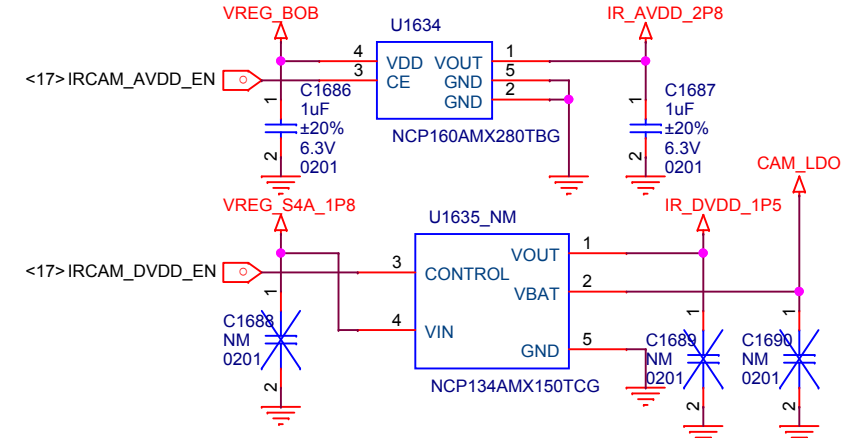

FRONT CAMERA

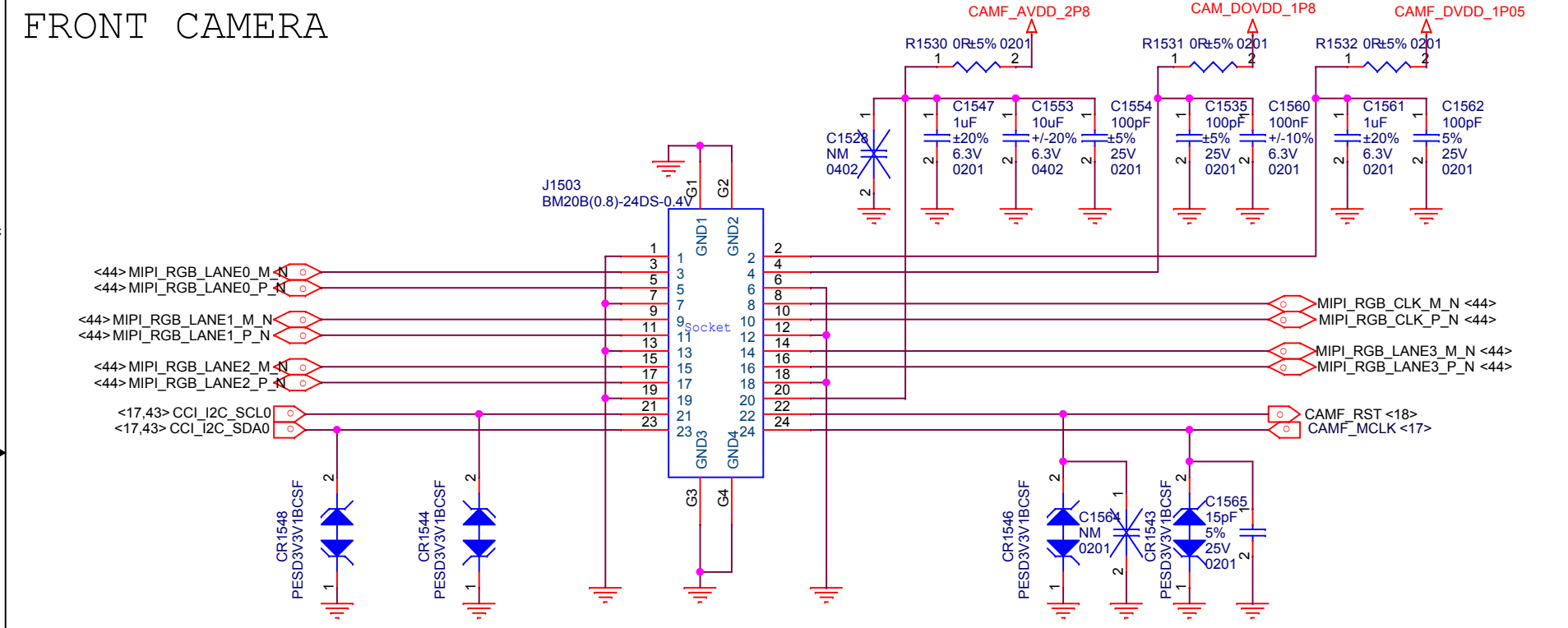

FRONT EMI

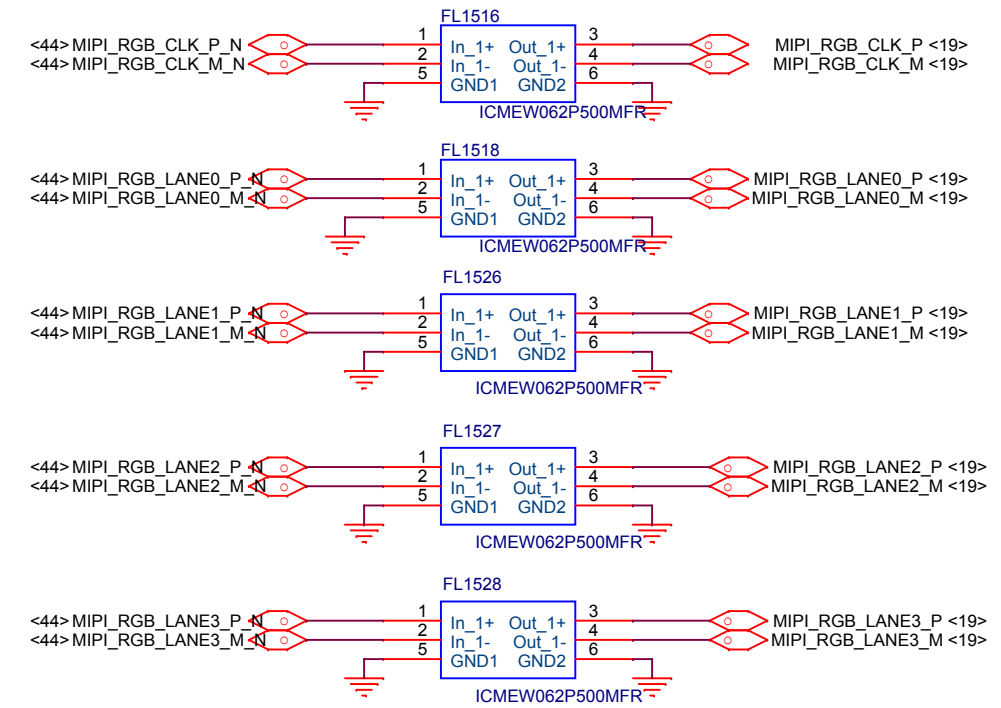

IR CAMERA

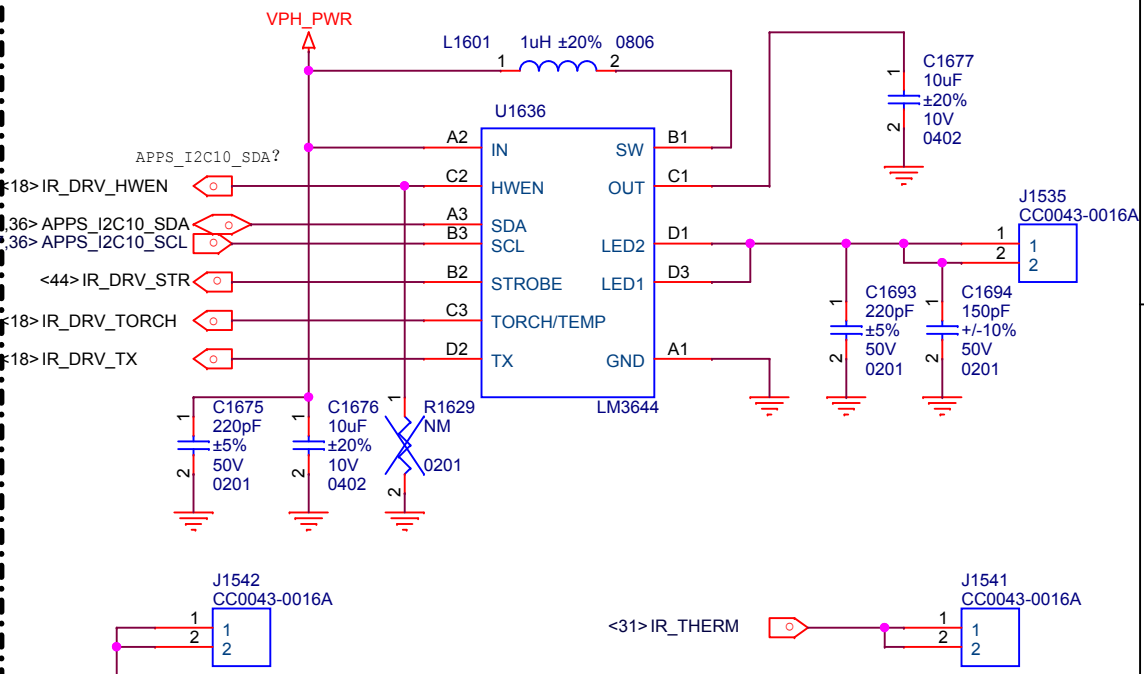
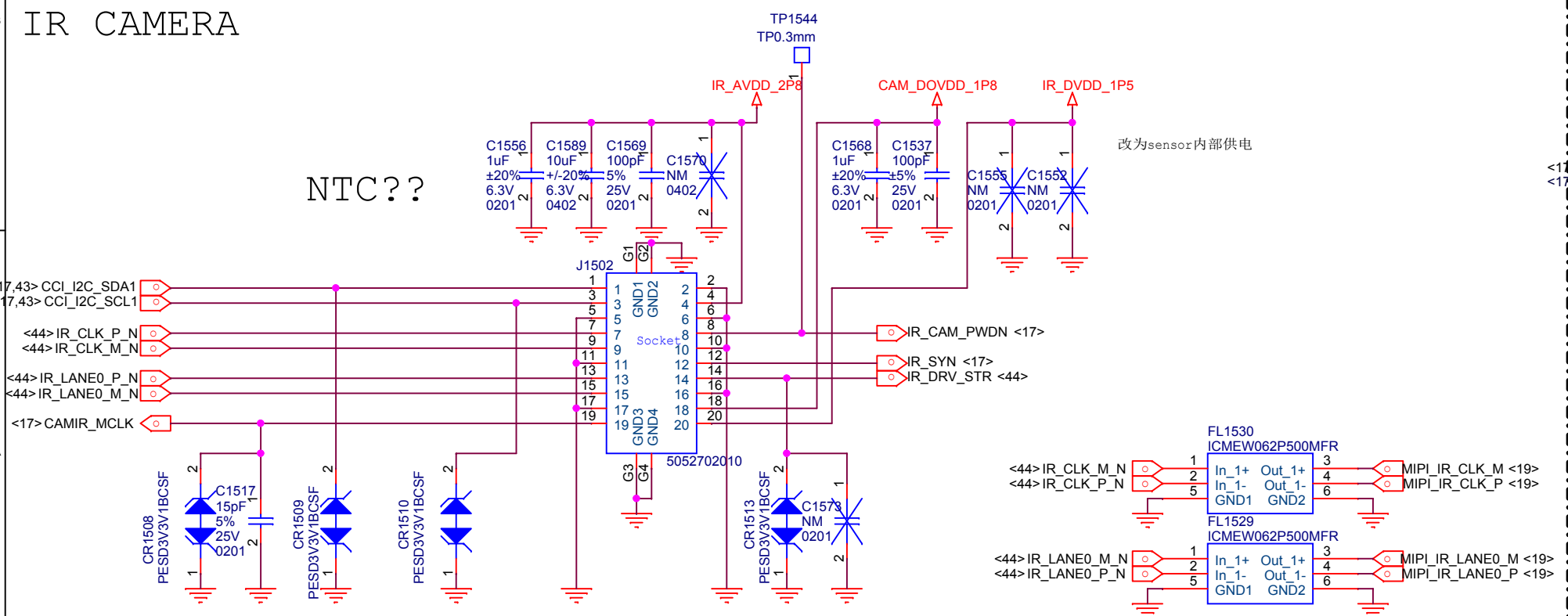

Title		E8	
Size	A3	Document Number	
Date:		Sheet	44 of 44

