

8. Level 3 Repair

DS

8-1. Block Diagram

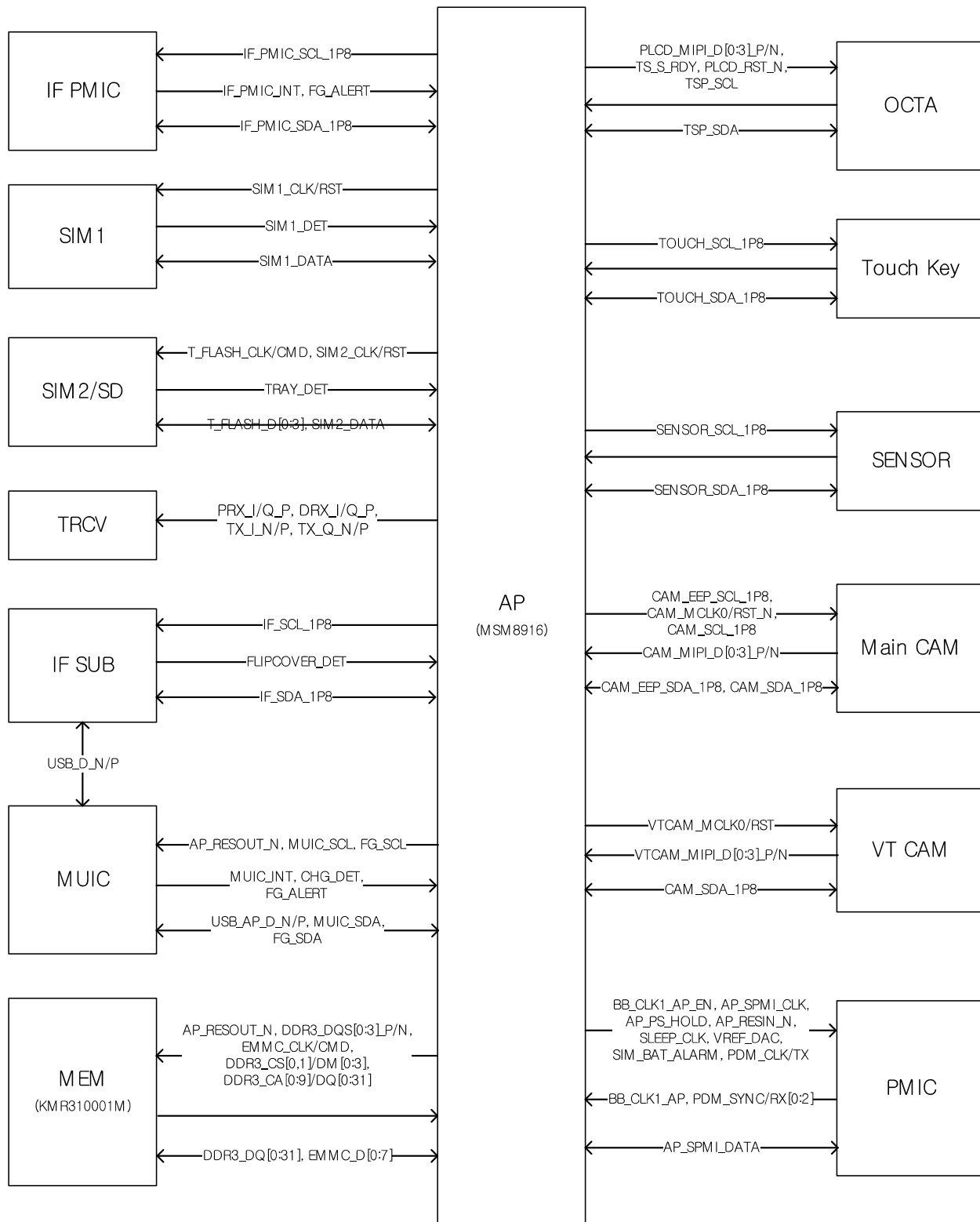

8-2. PCB Diagrams
8-2-1. Main PCB Top

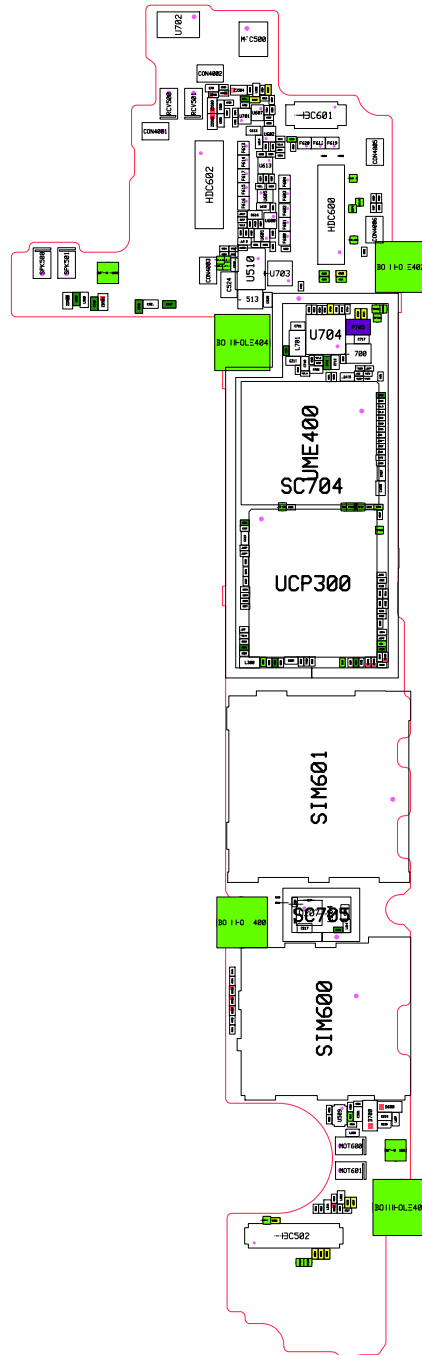

8-2-2. Bottom

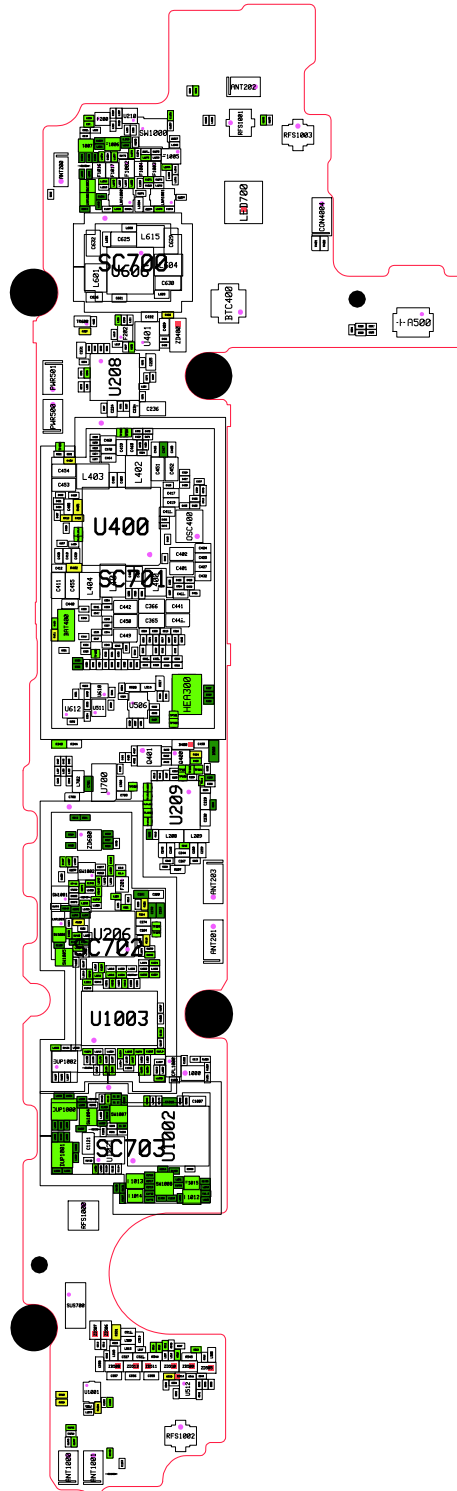

8-2-3. Equipments

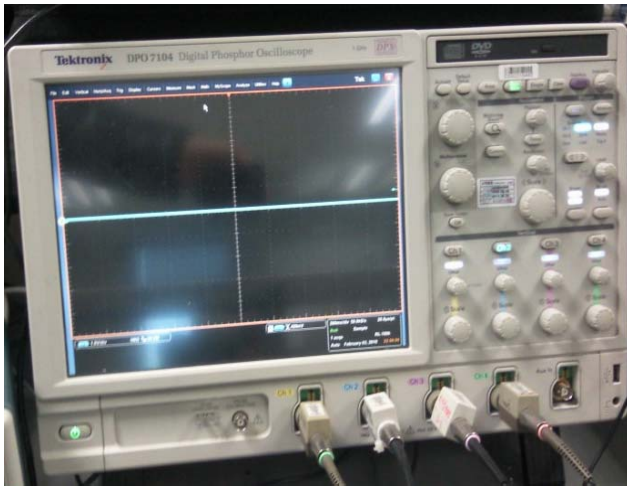

↑ Oscilloscope



↑ Digital Multimeter



↑ Power Supply



↑ + driver, ESD Safe Tweezer

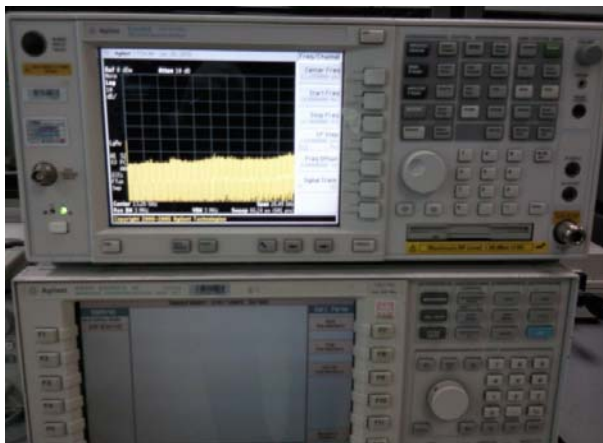

↑ 8960 & Spectrum Analyzer



↑ Soldering iron

8-3. Flow Chart of Troubleshooting

8-3-1. Power On

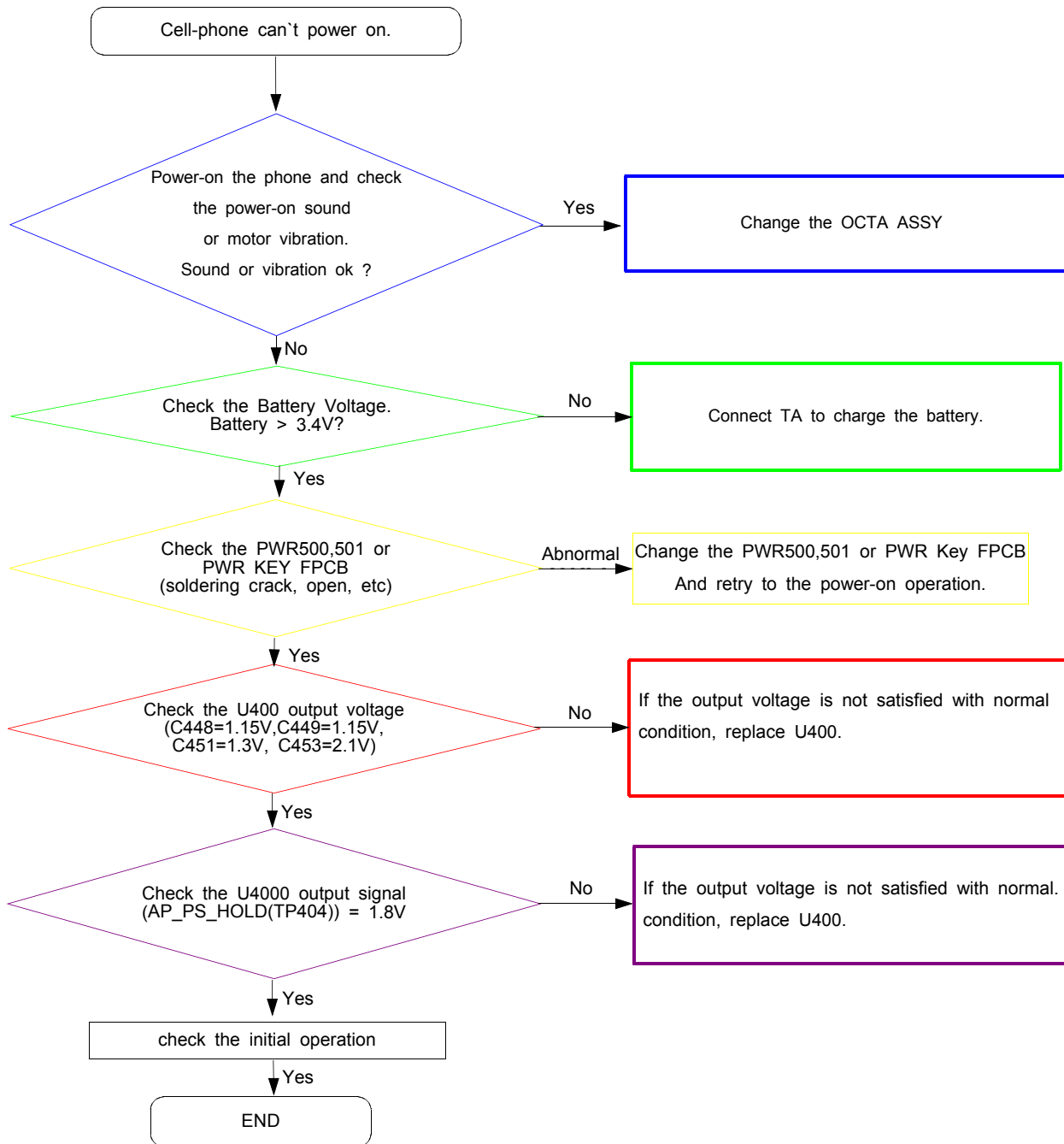

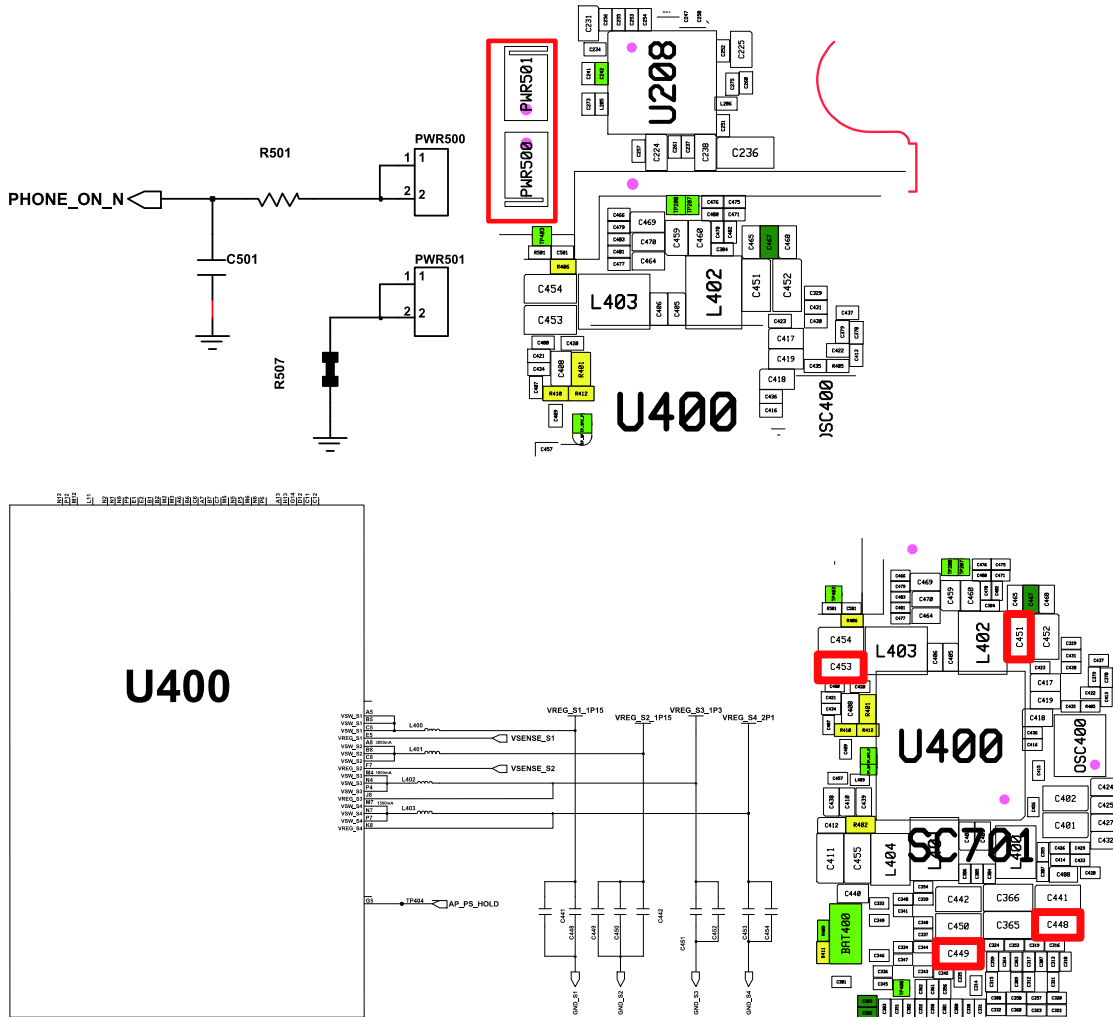

8-3-2. Initial

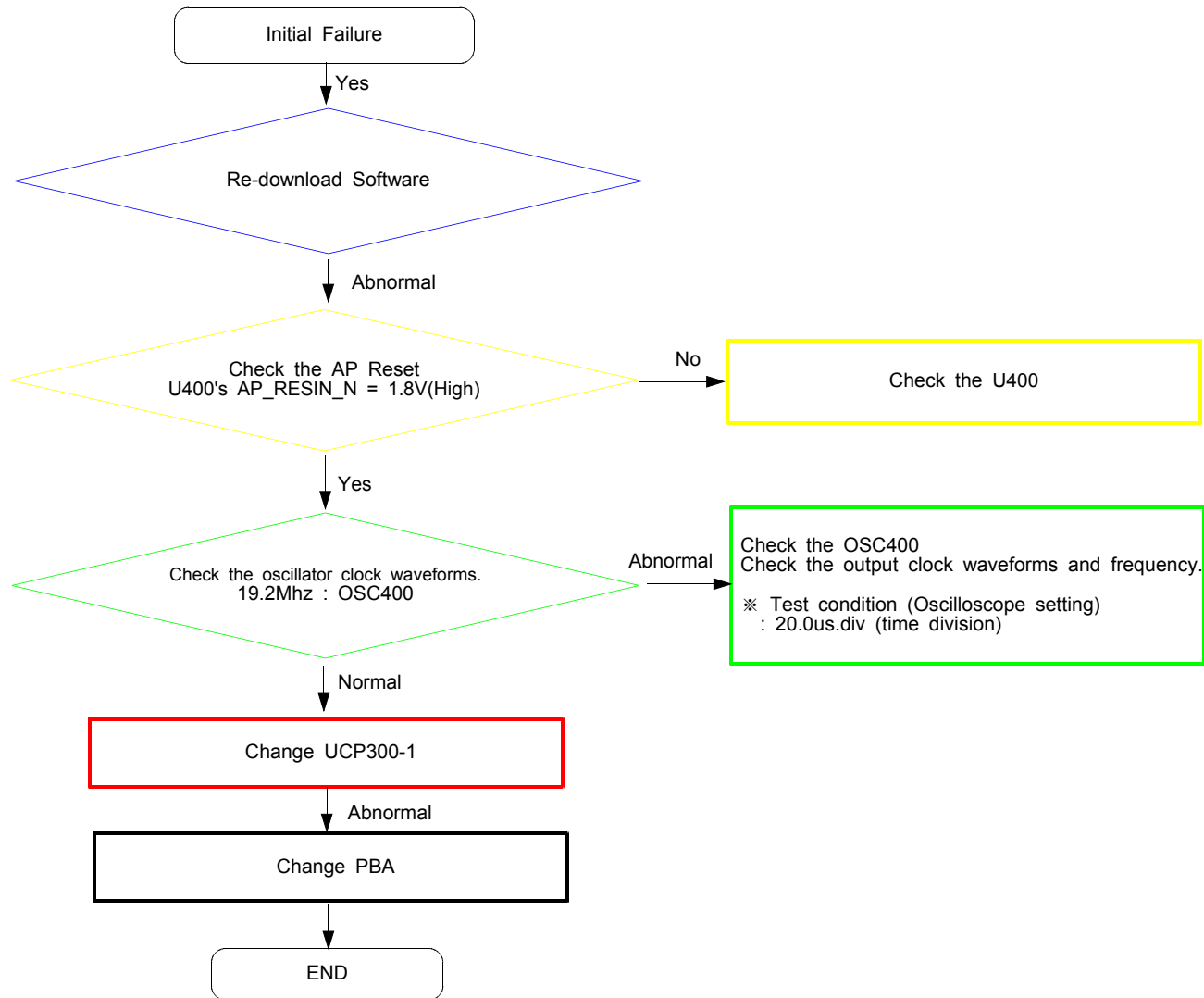

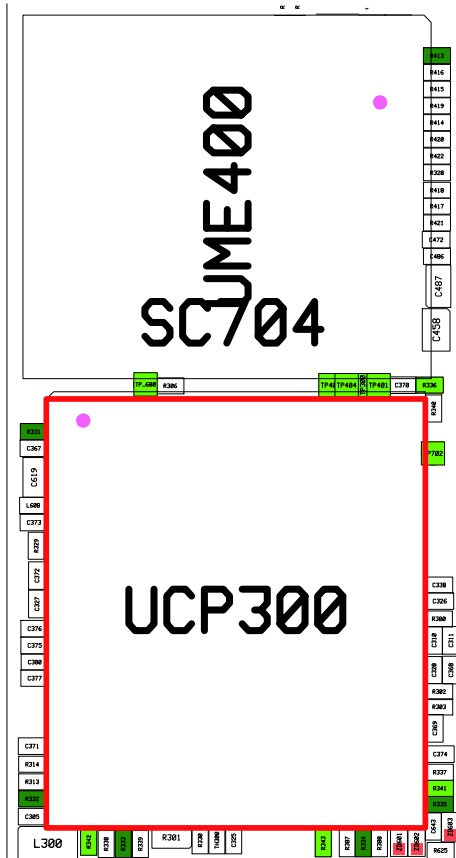
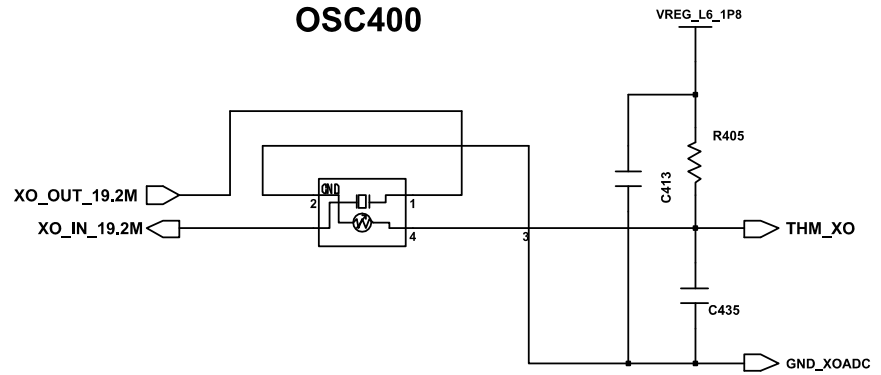
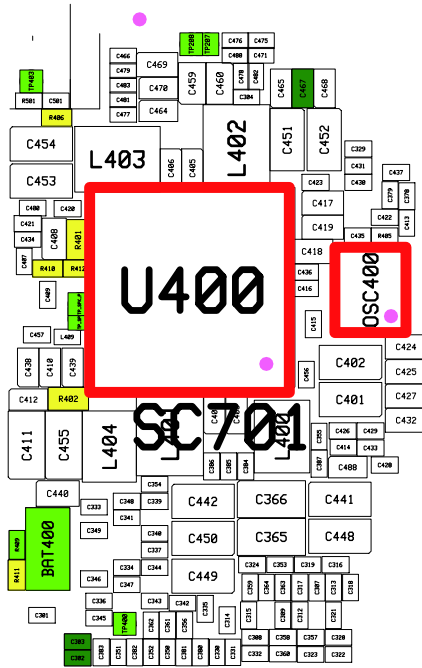

8-3-3. No Service

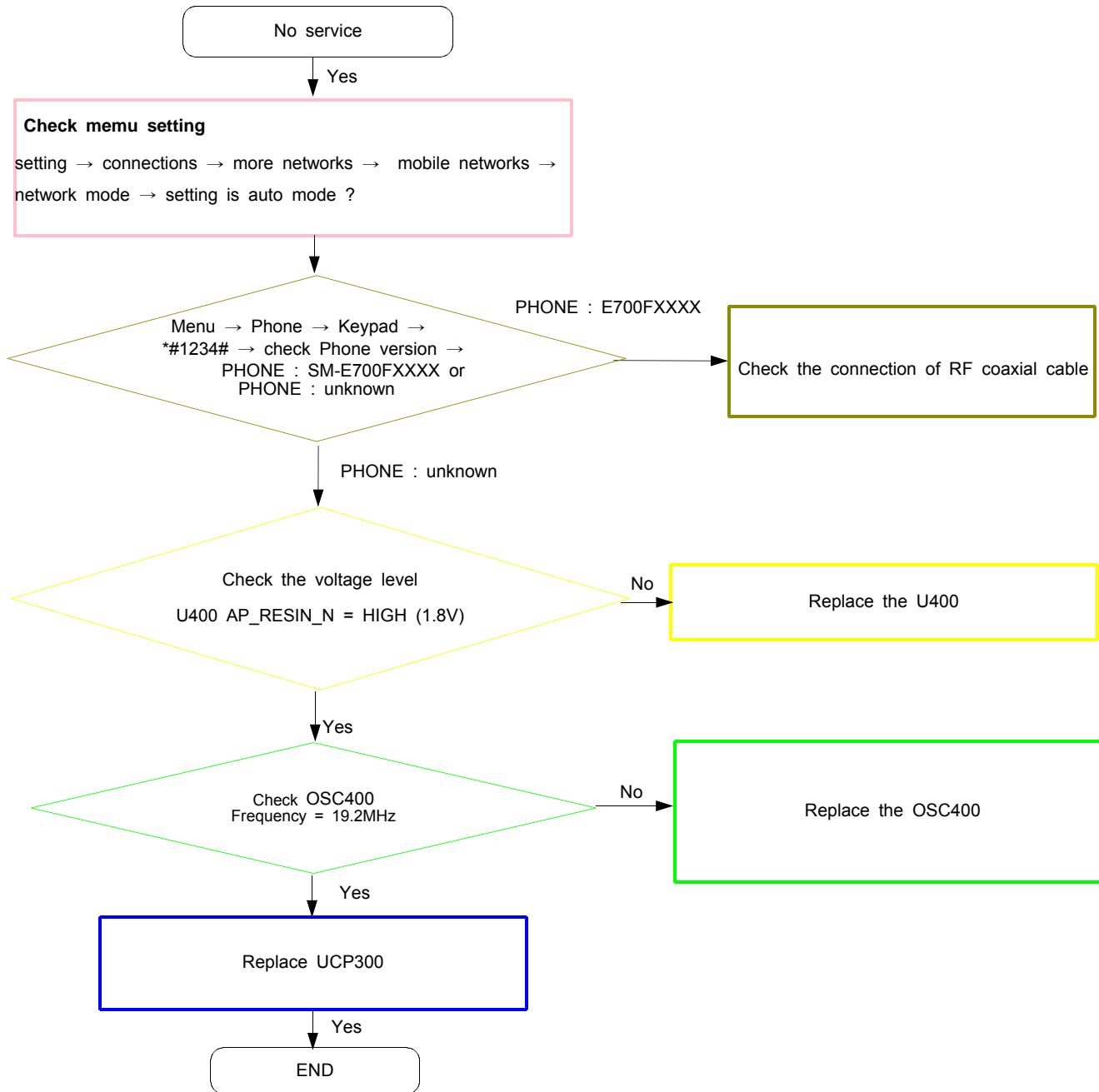

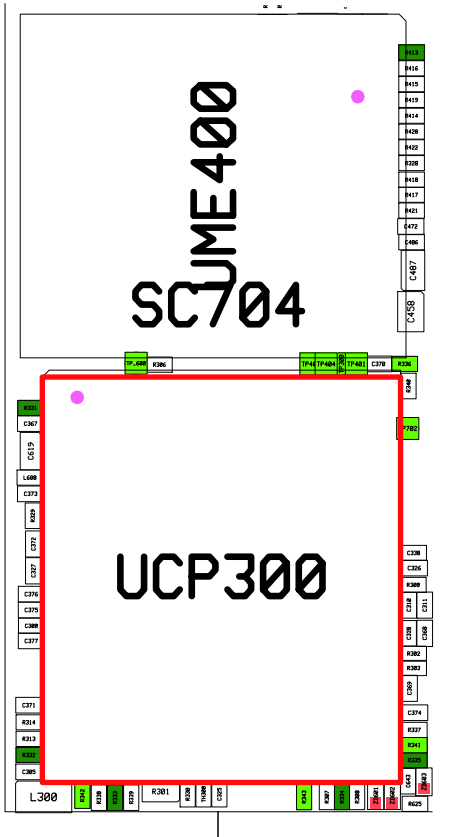
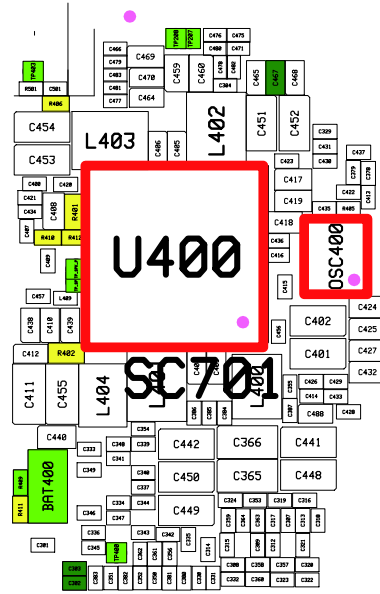
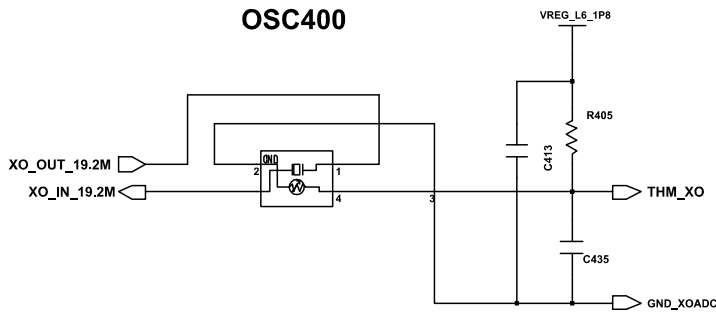

8-3-4. SIM1 Part

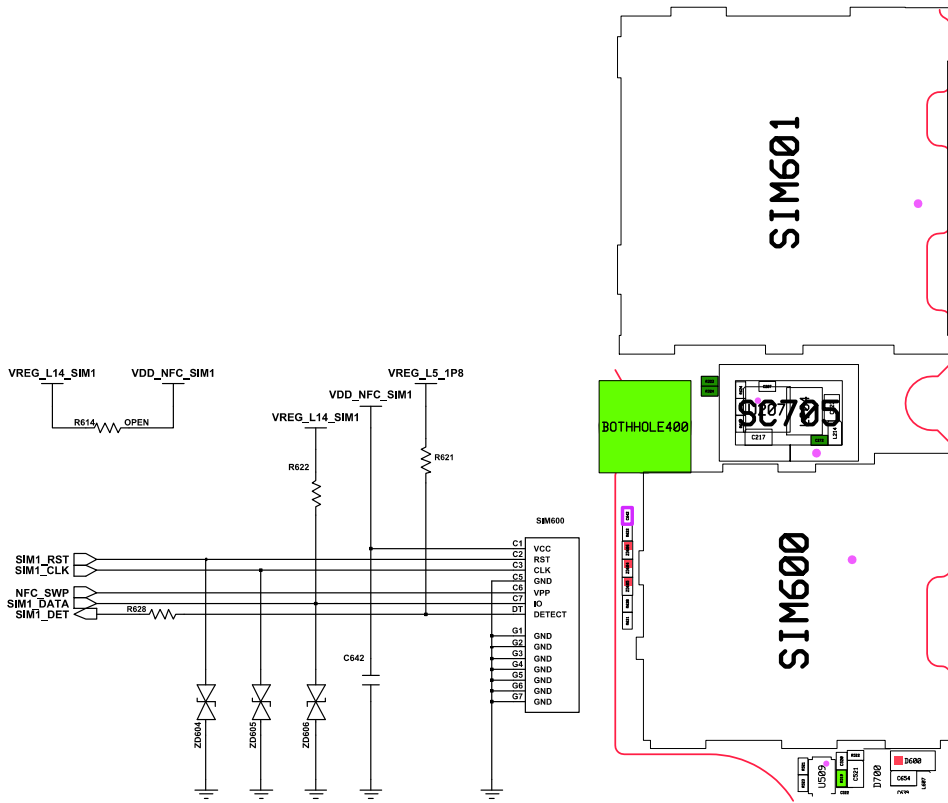
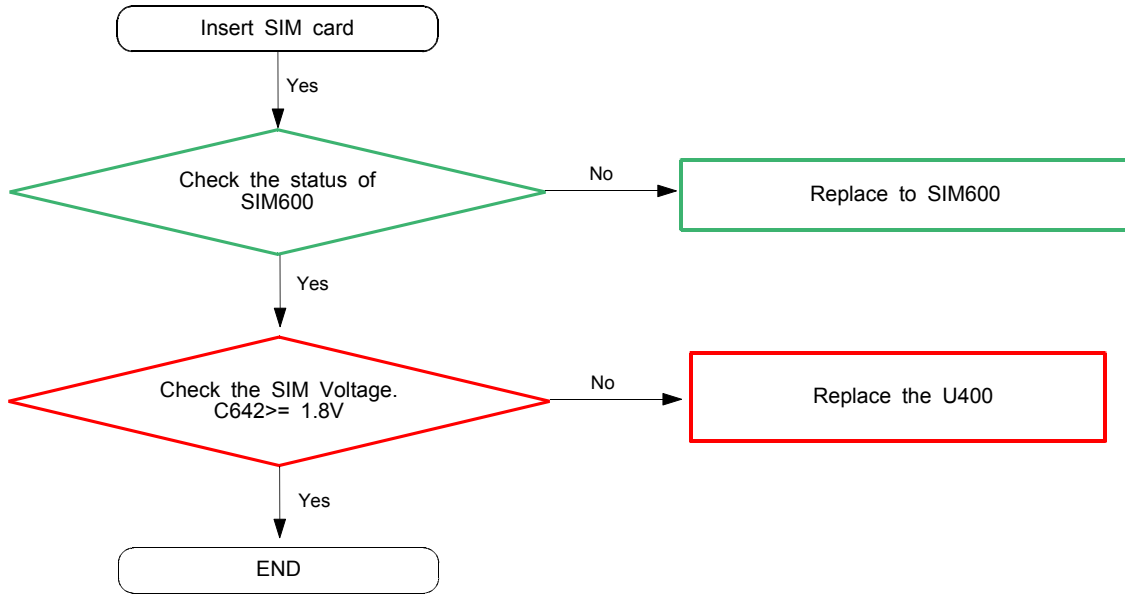

8-3-5. Hybrid Socket Part

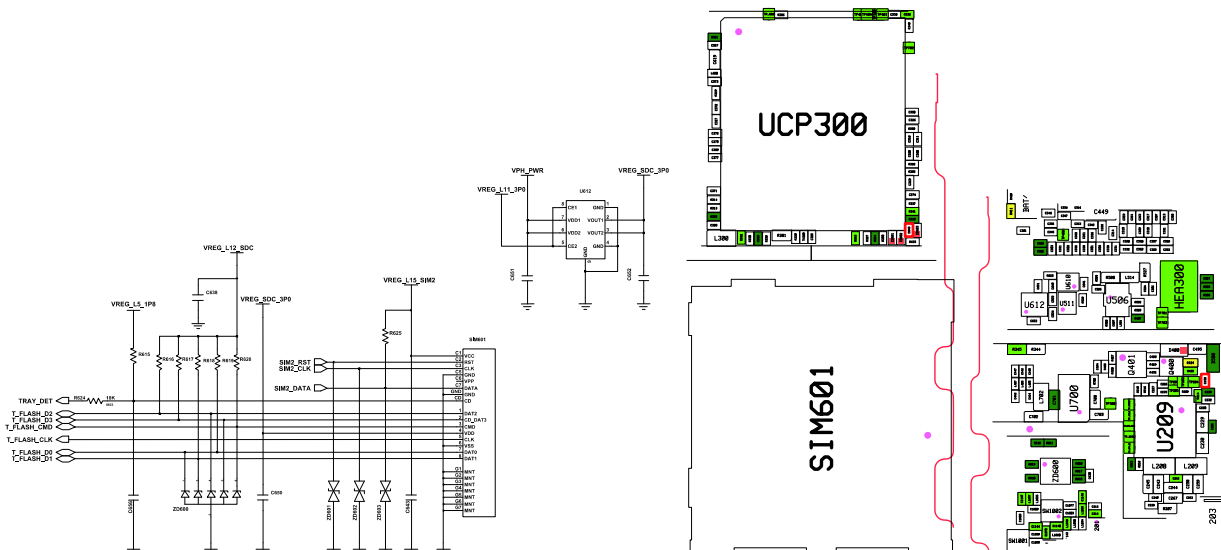
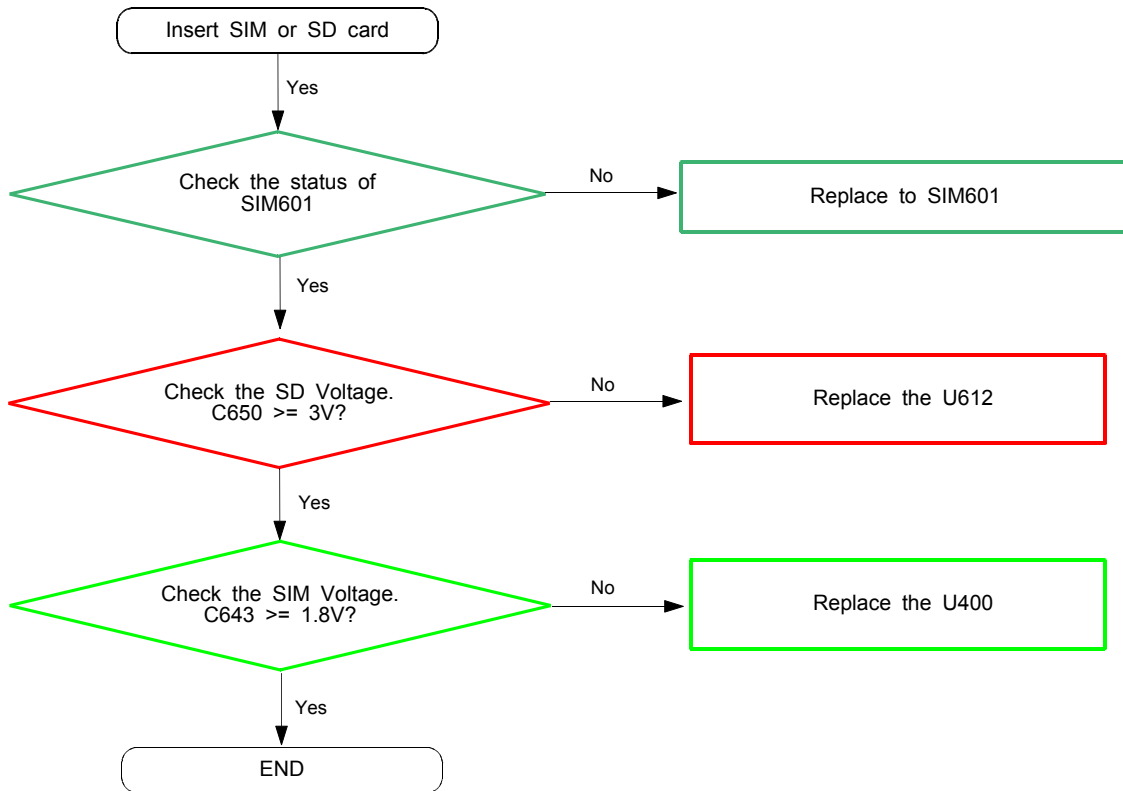

8-3-6. Charging Part

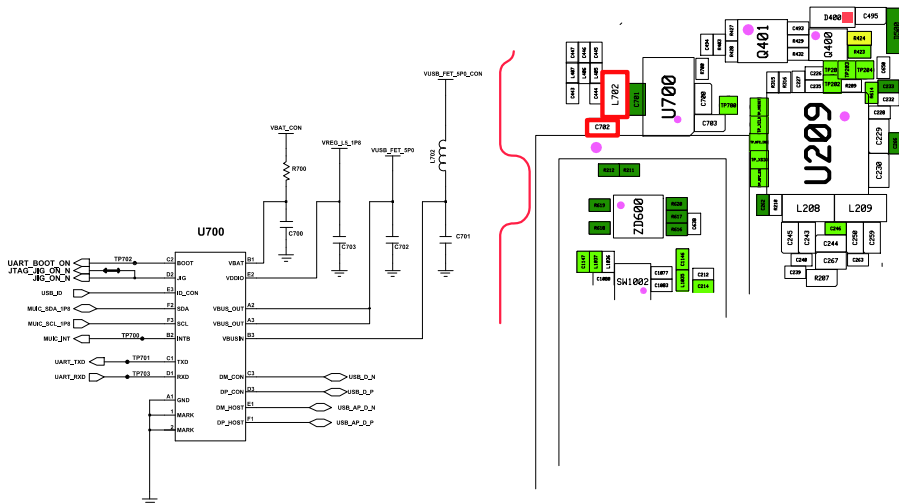
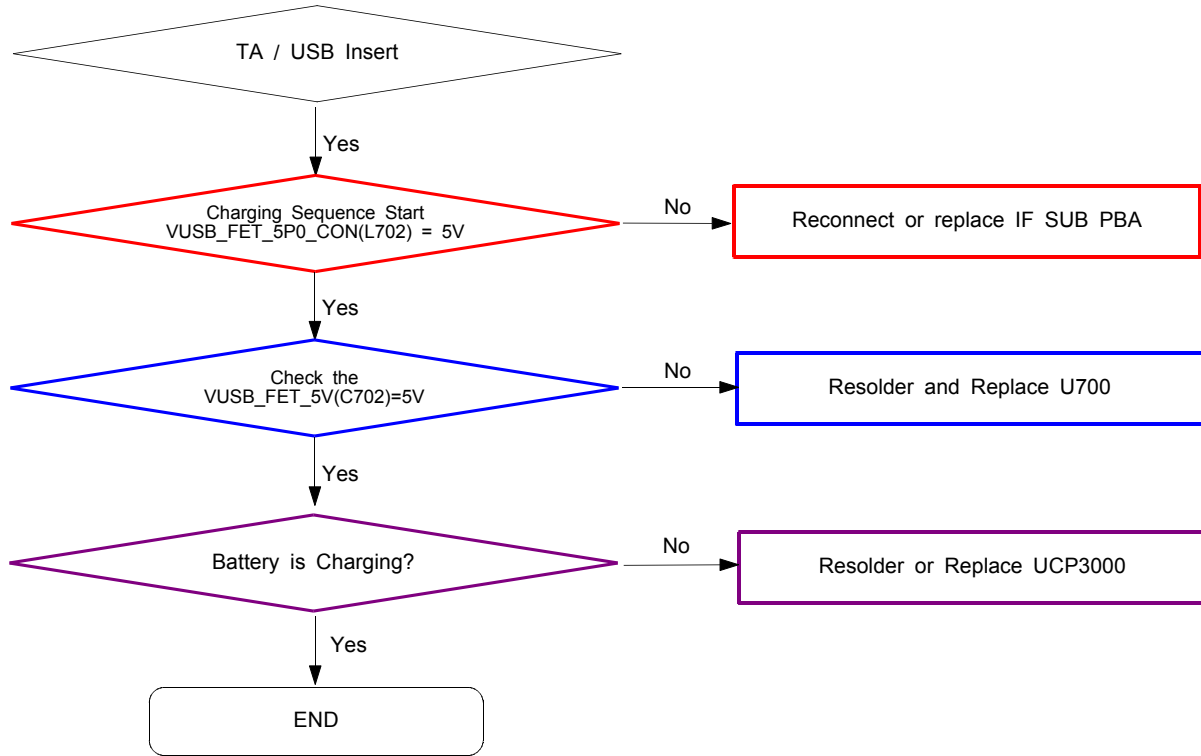

8-3-7. ACC Sensor

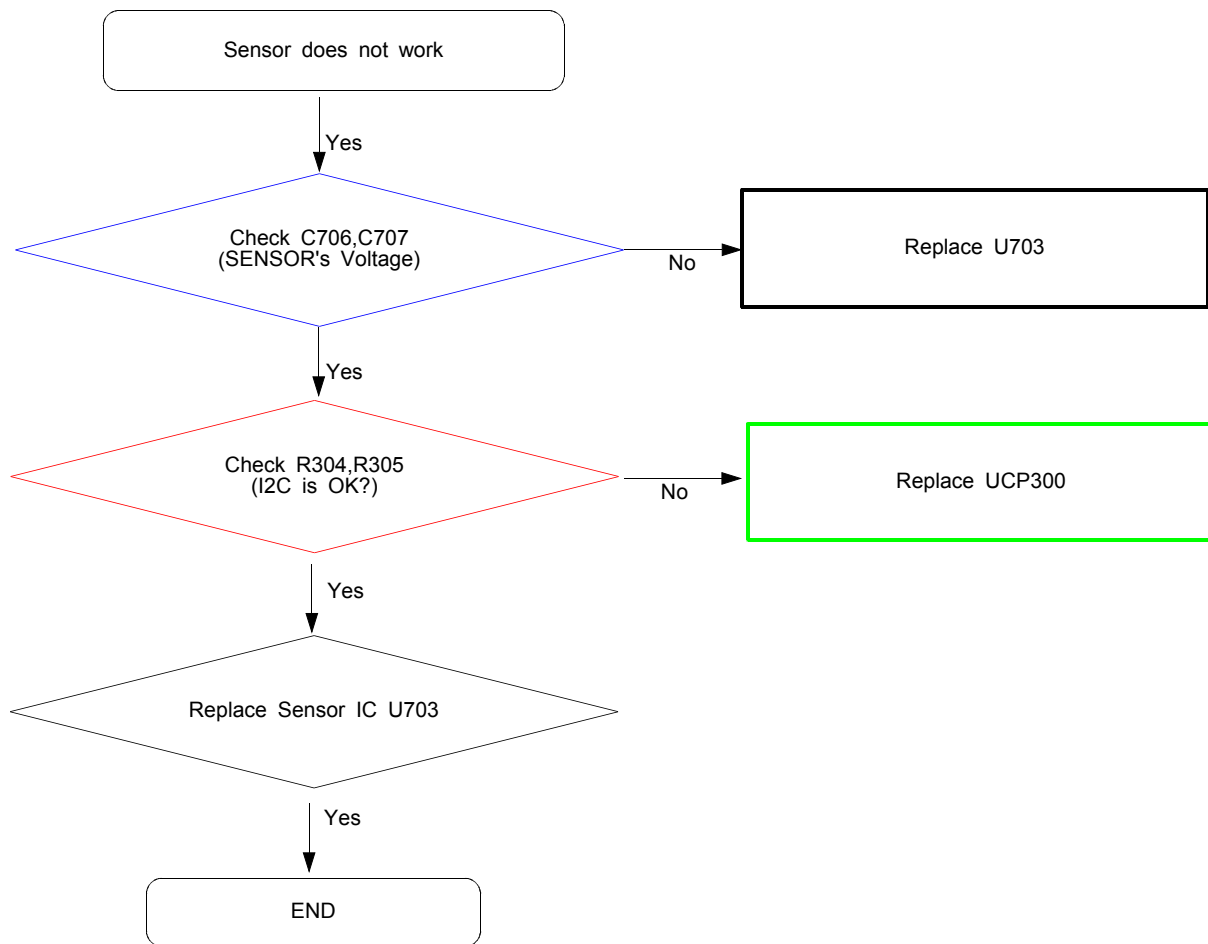

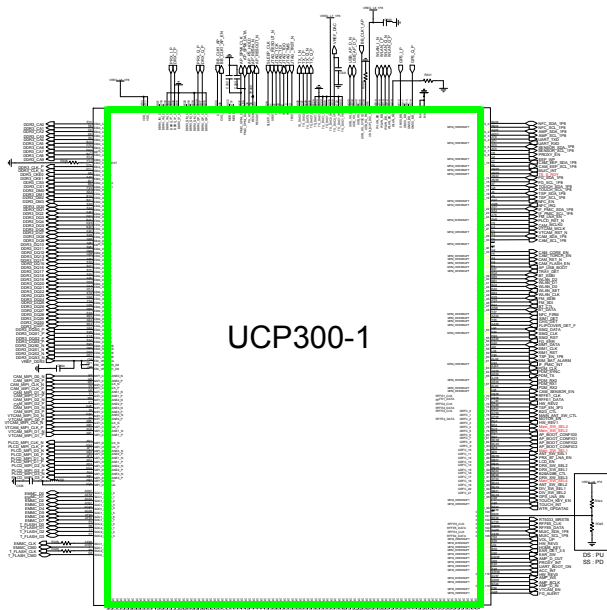
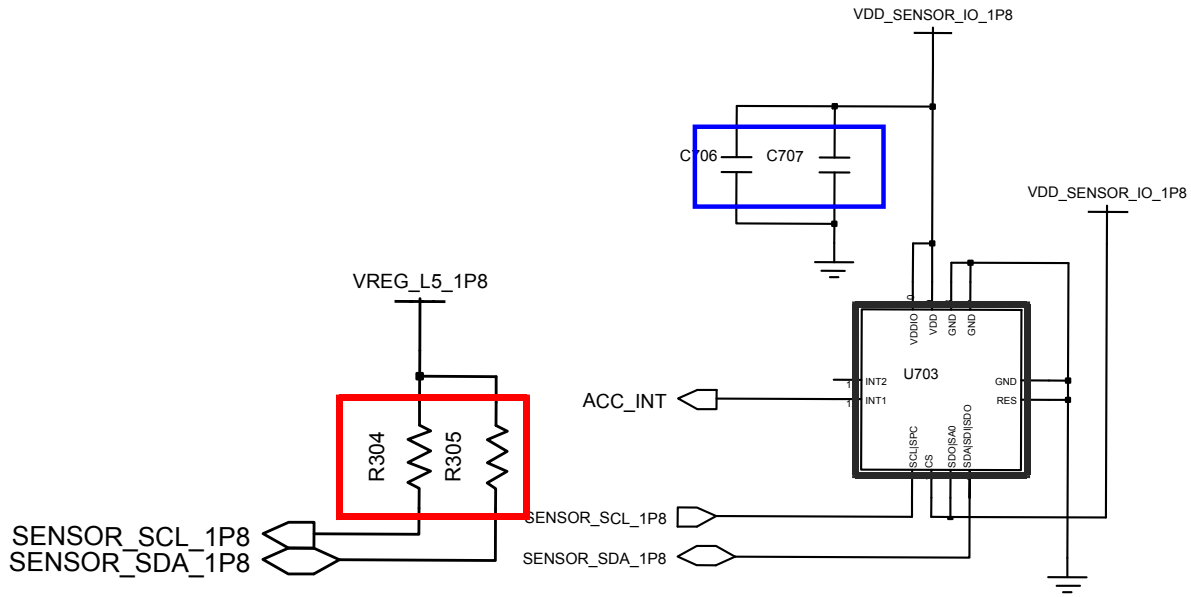

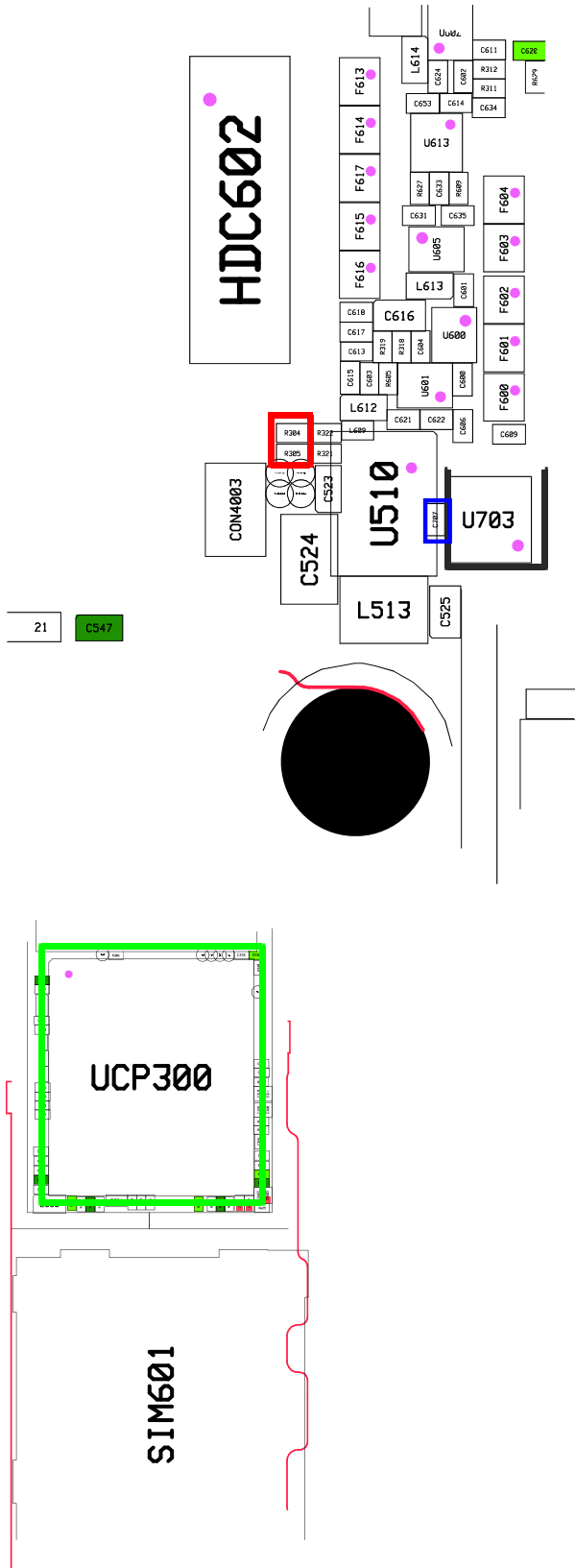

8-3-8. Proximity Detector

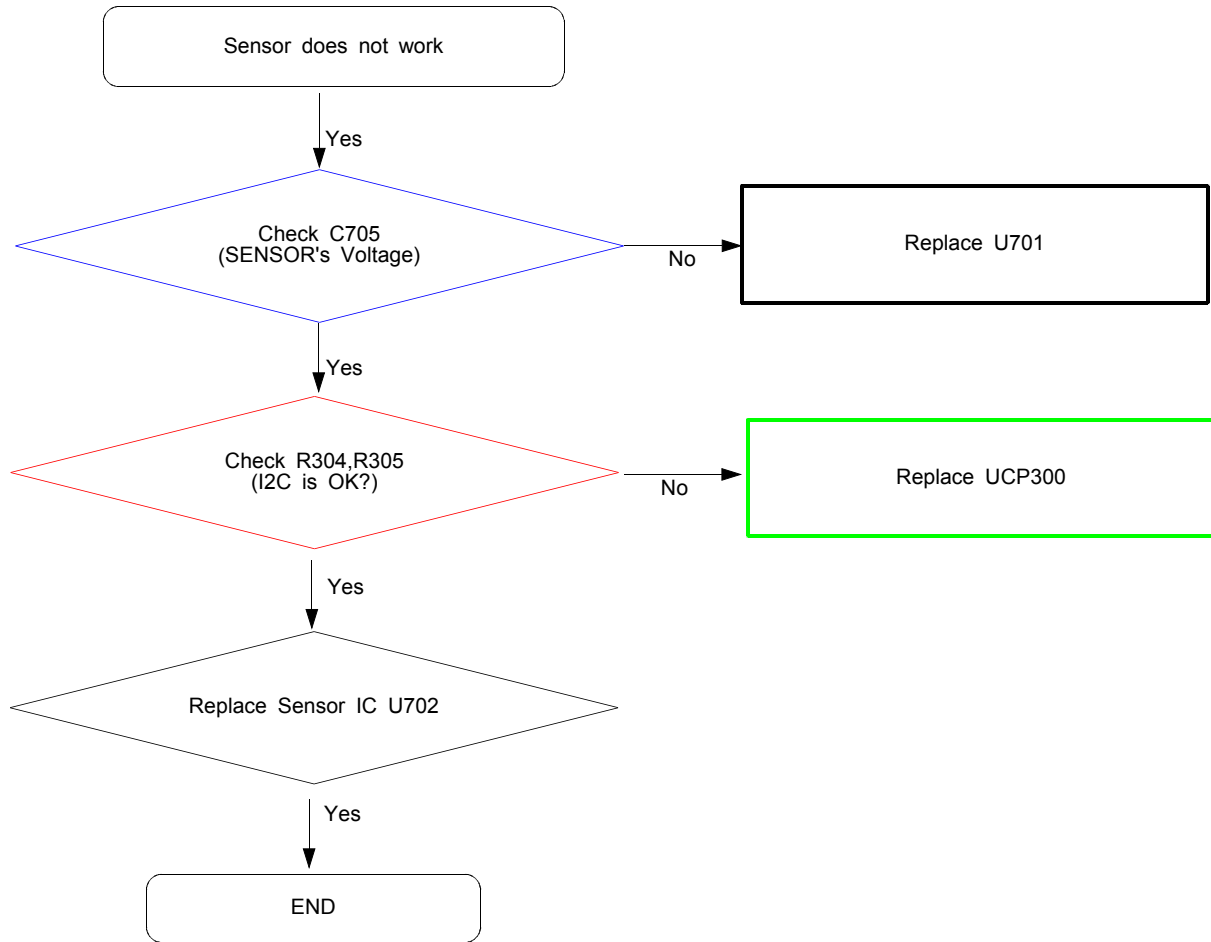

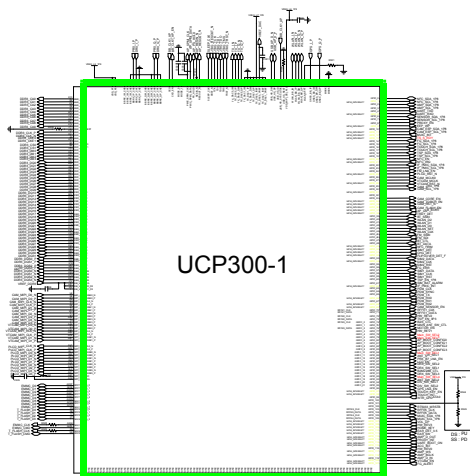
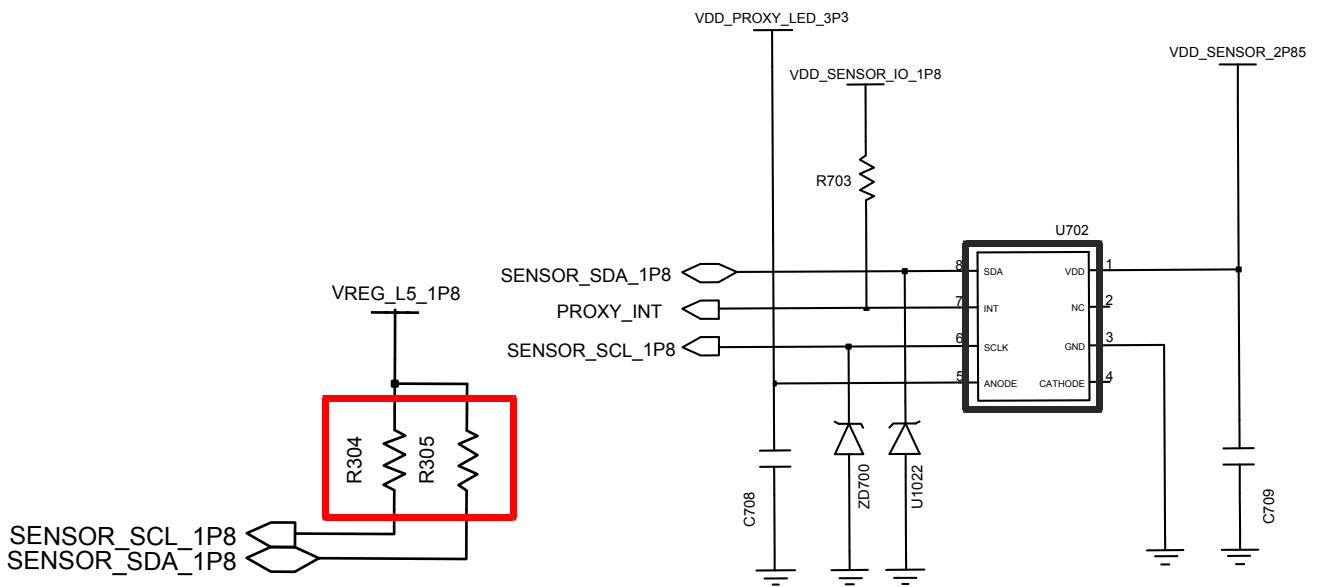
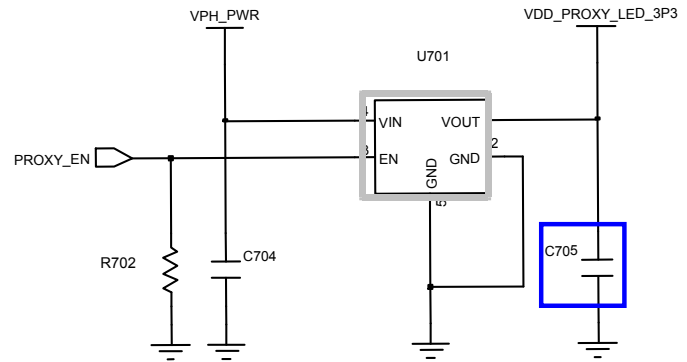

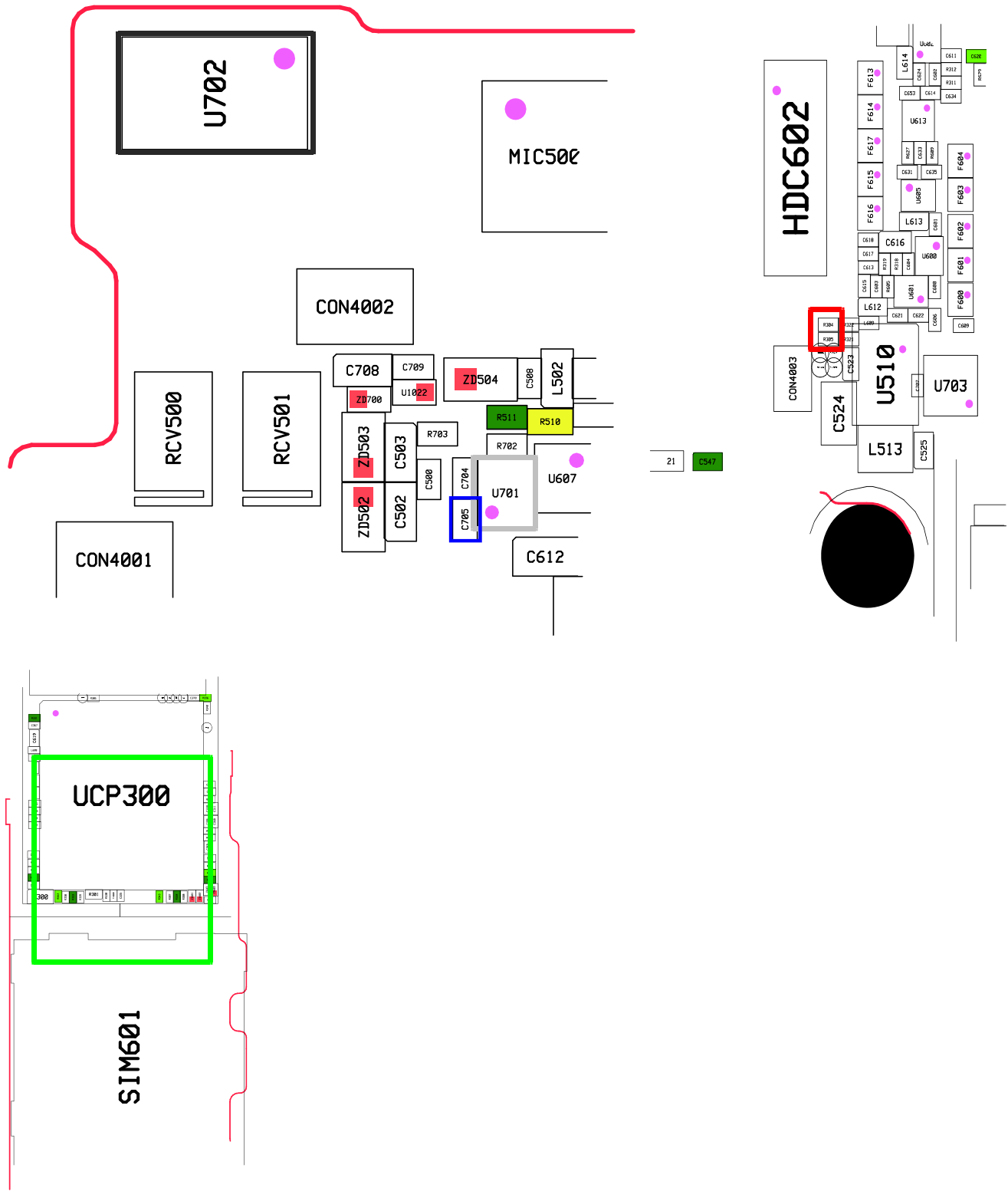

8-3-9. Speaker Part

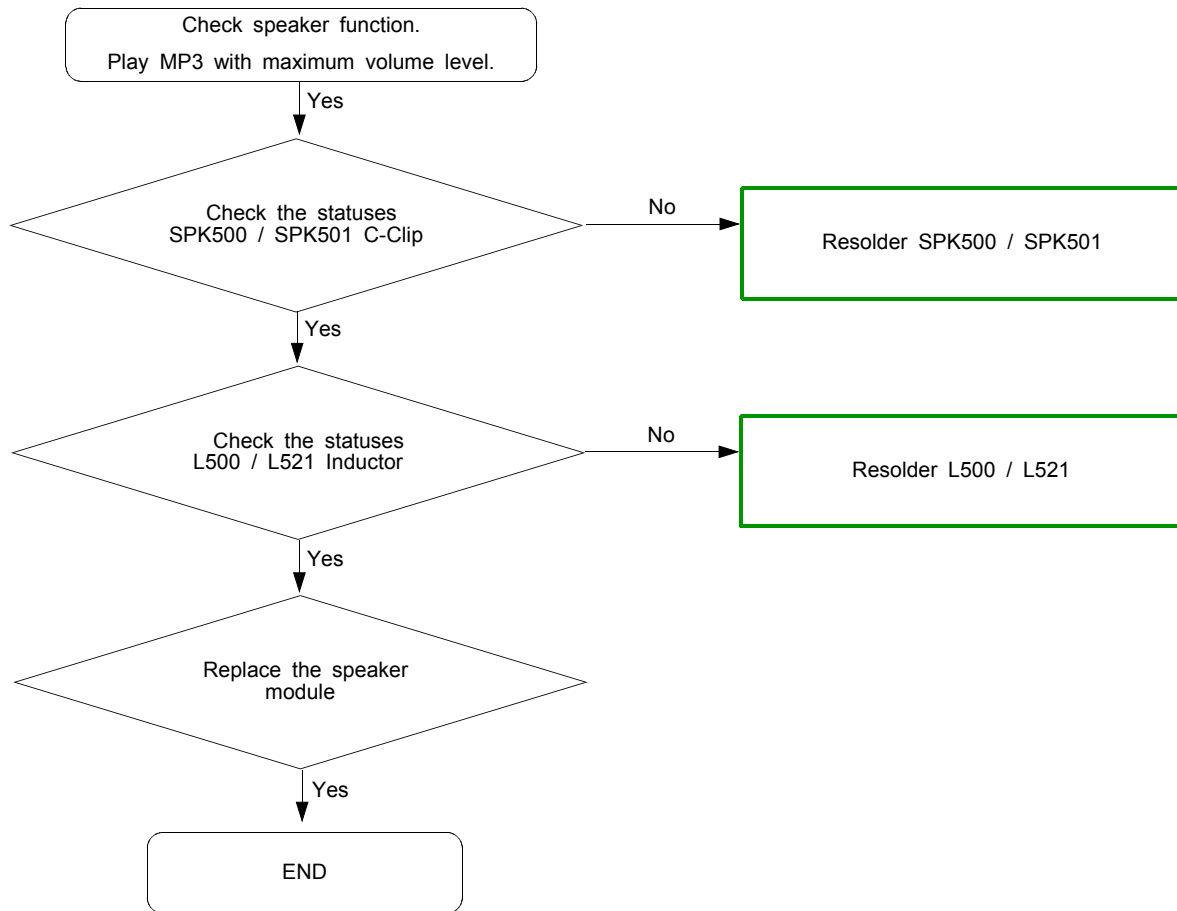

..

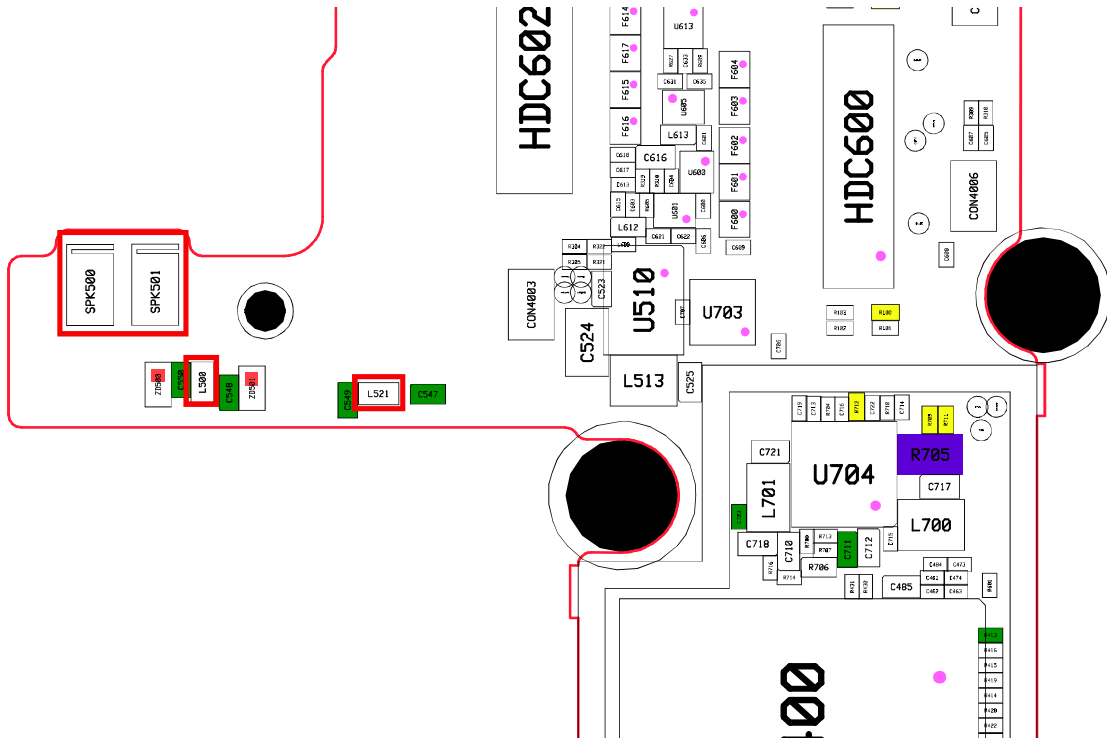
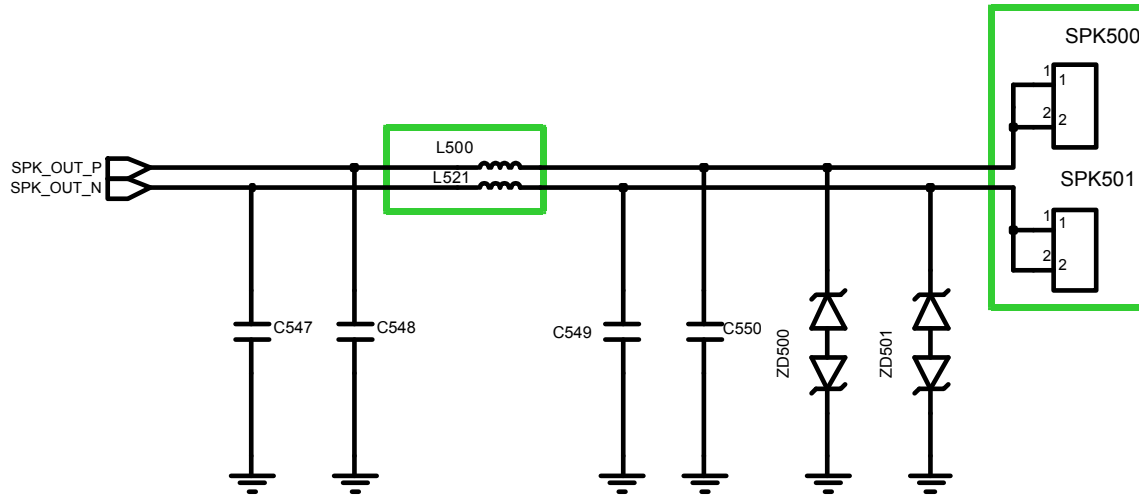

8-3-10. Receiver Part

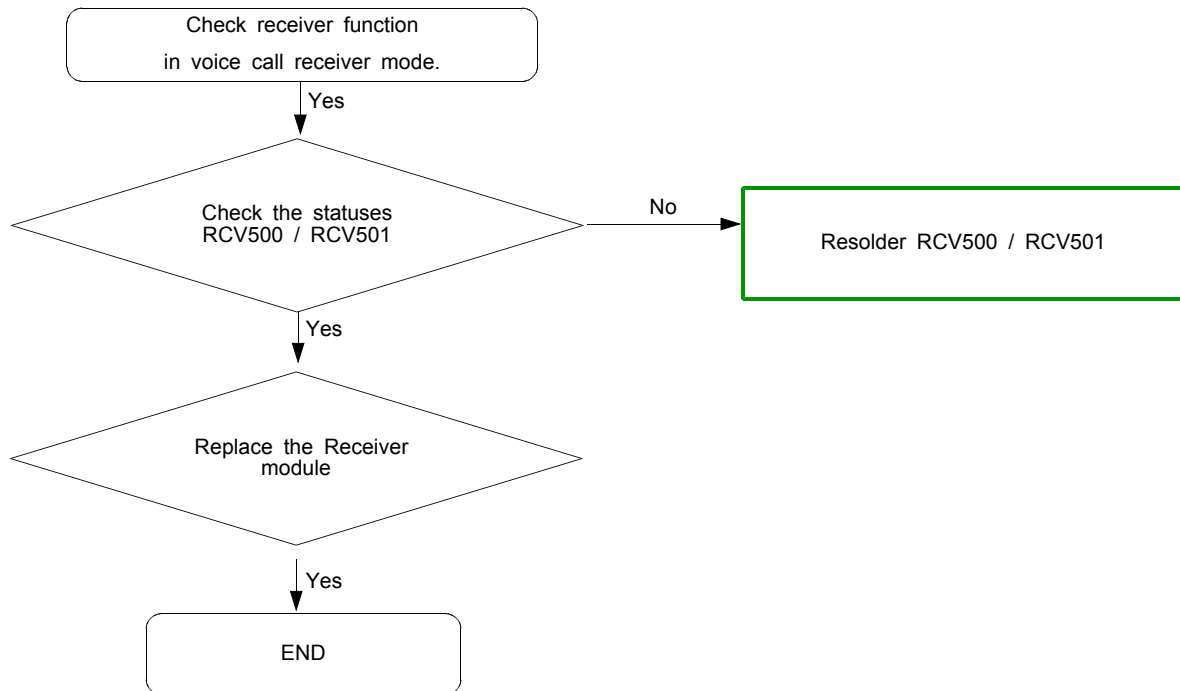

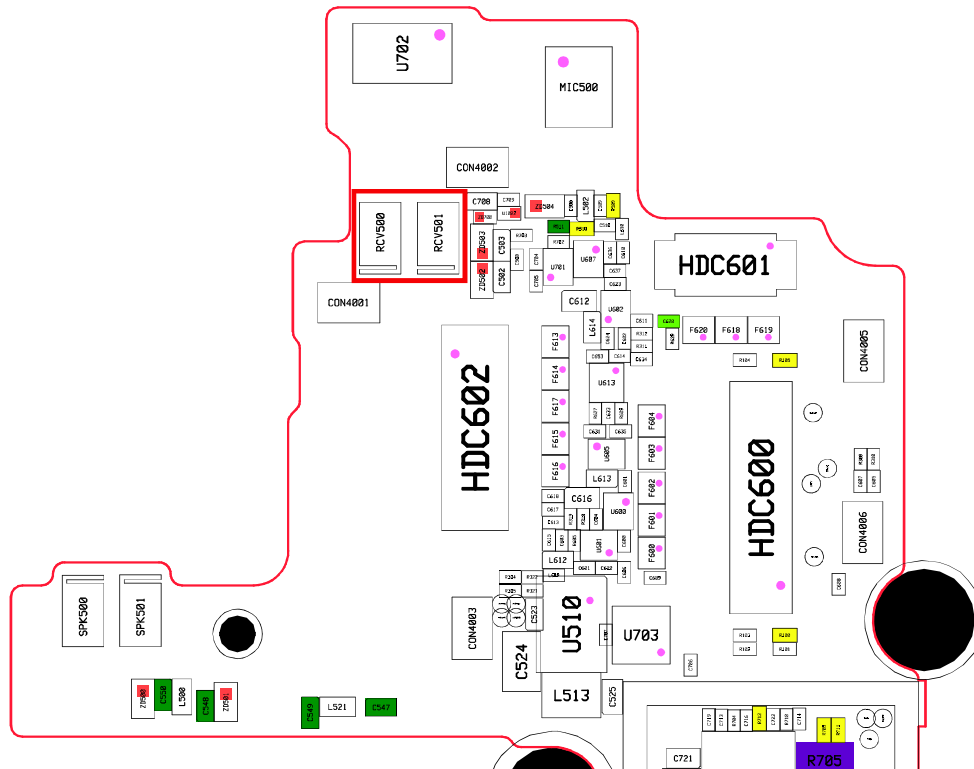
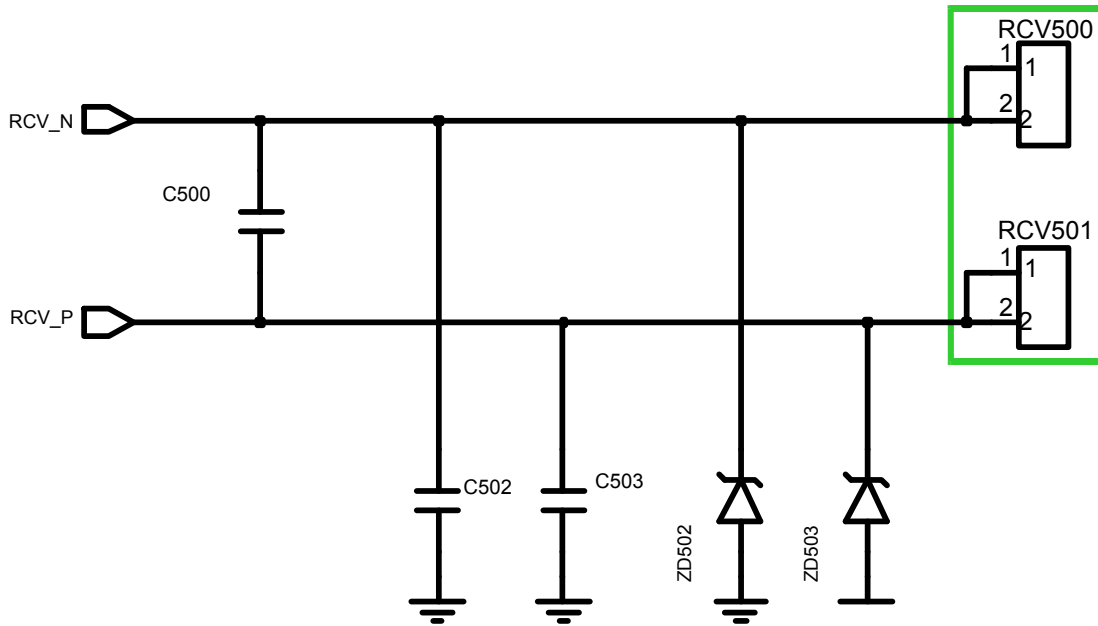

8-3-11. BT Part

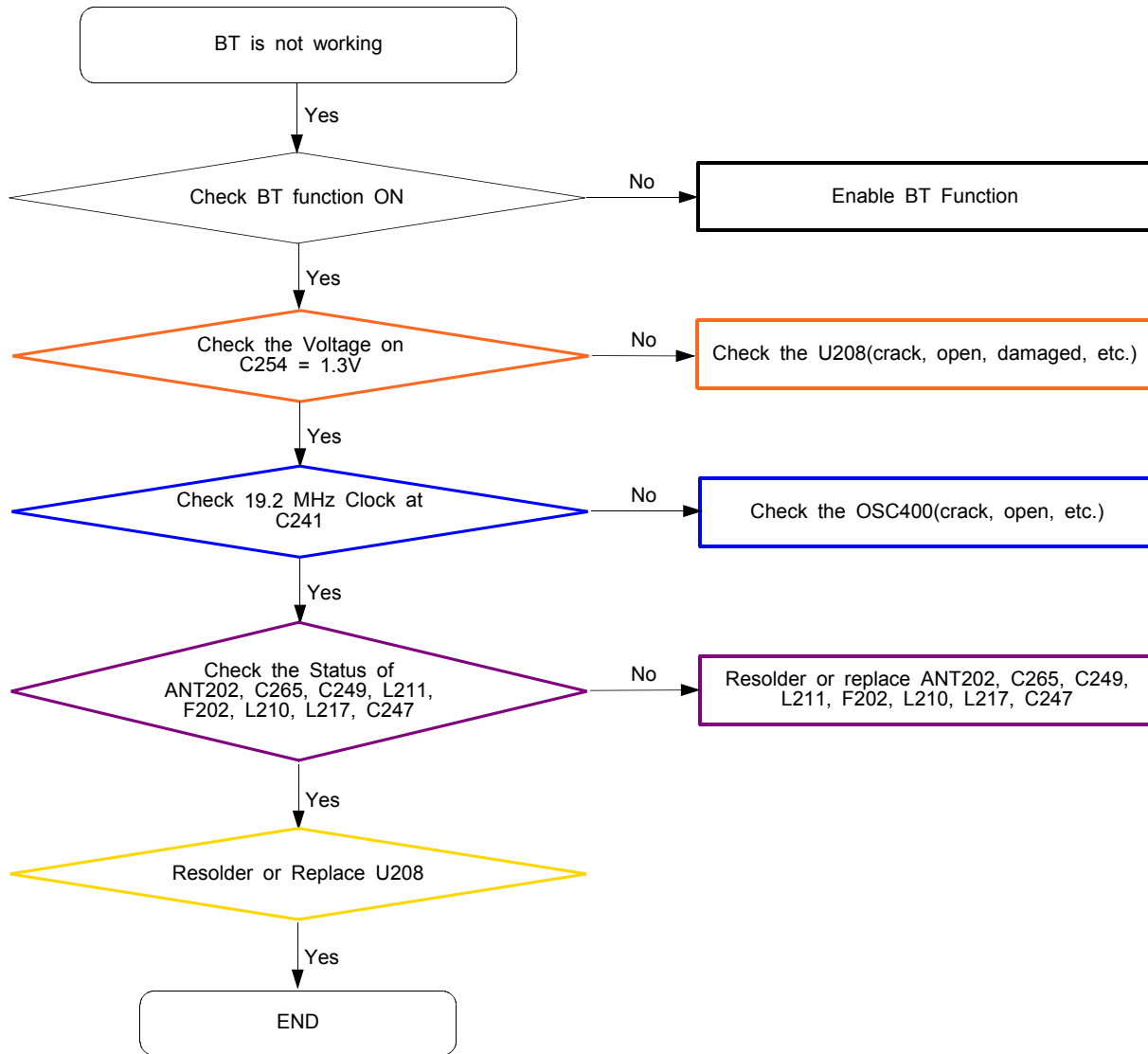

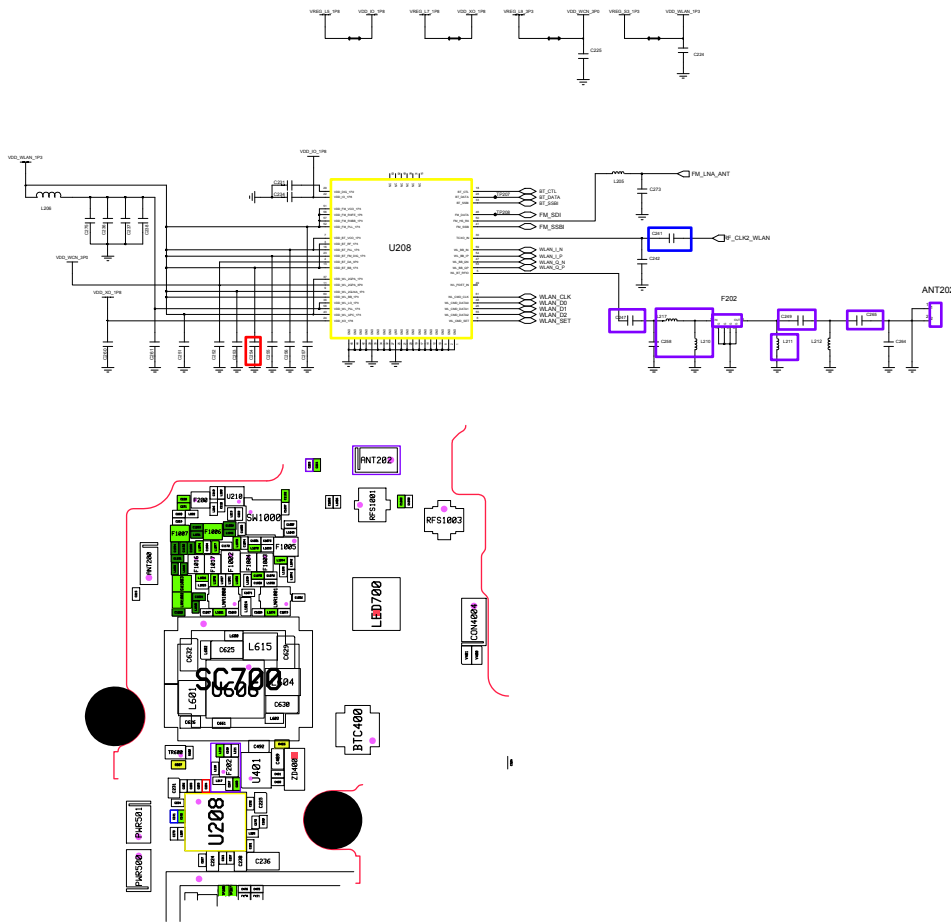

8-3-12. WIFI Part

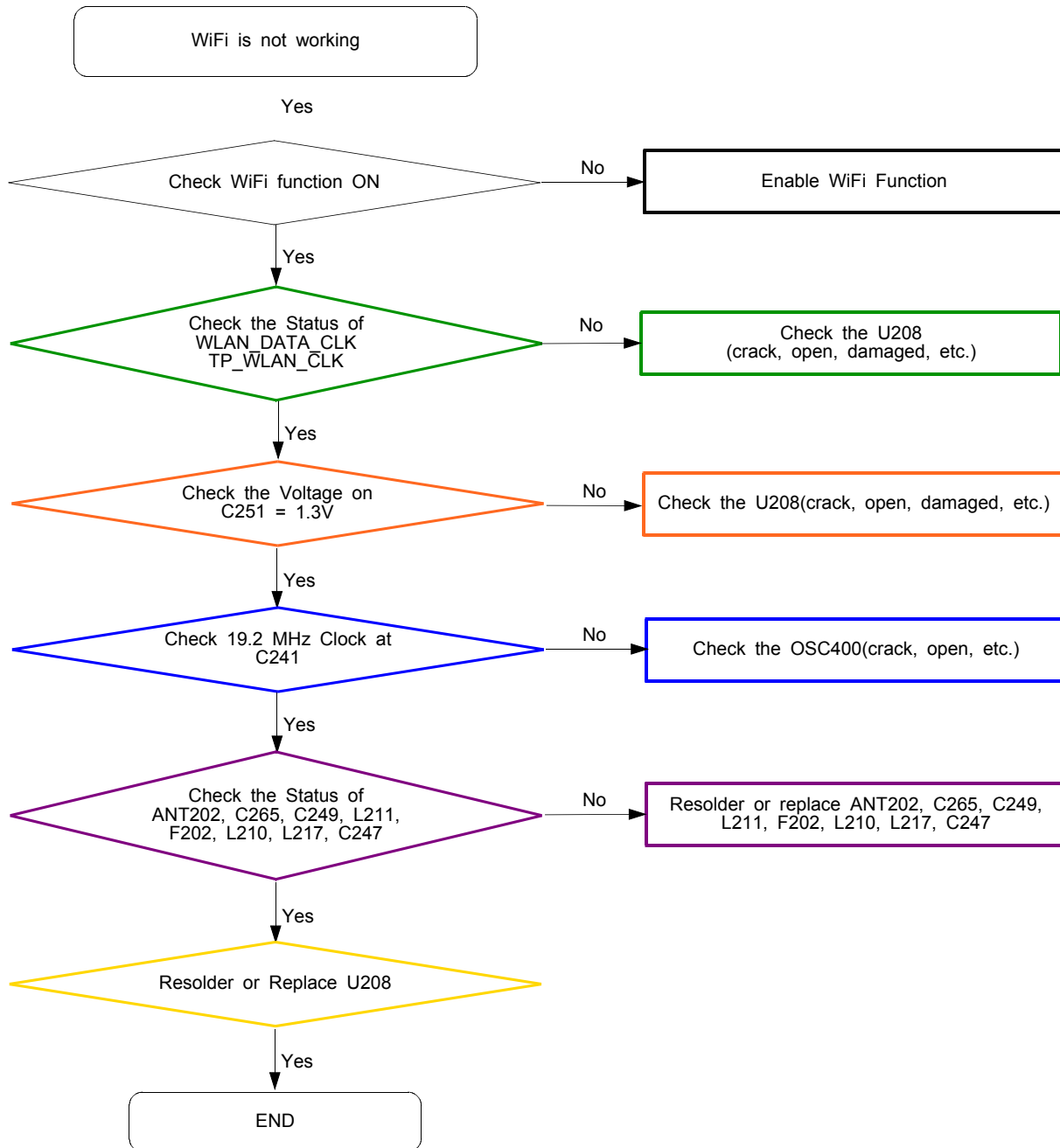

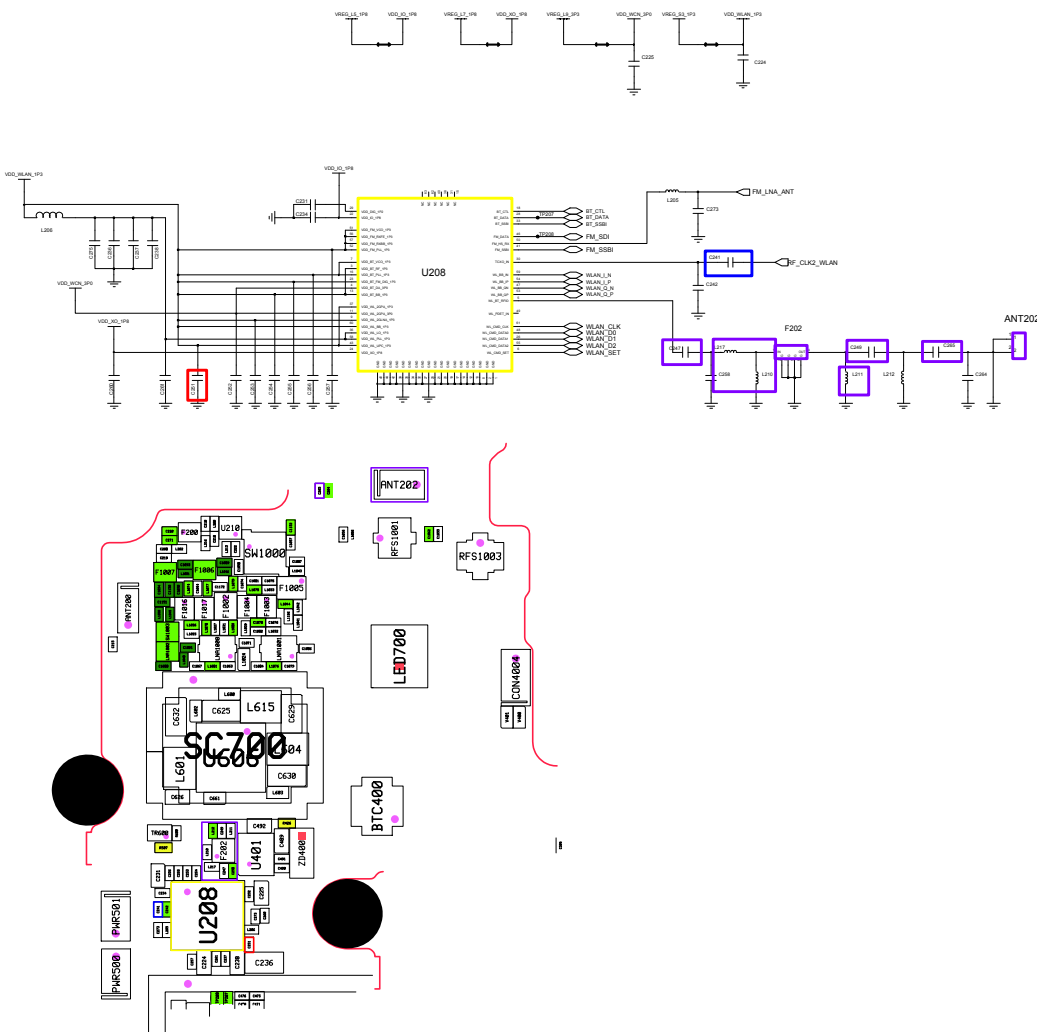

8-3-13. GPS Part

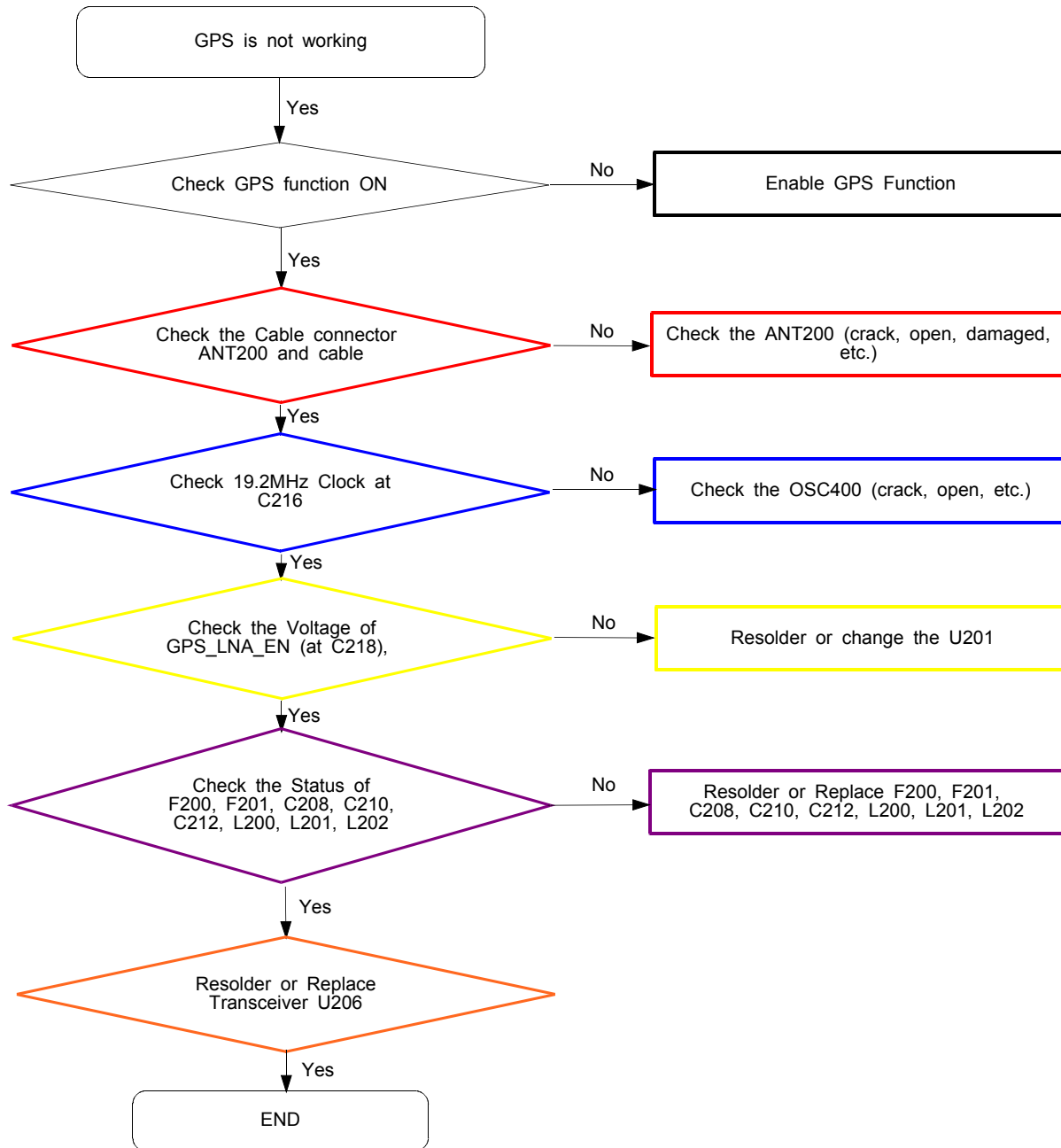

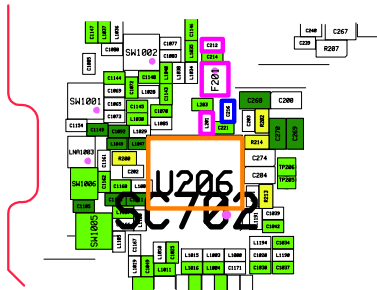
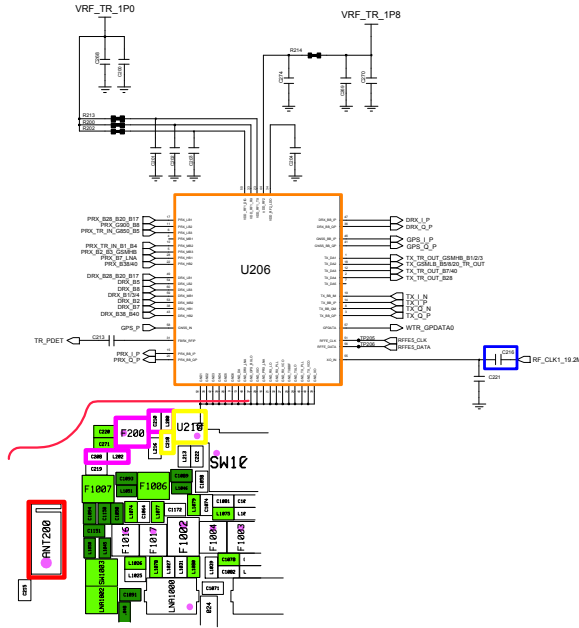
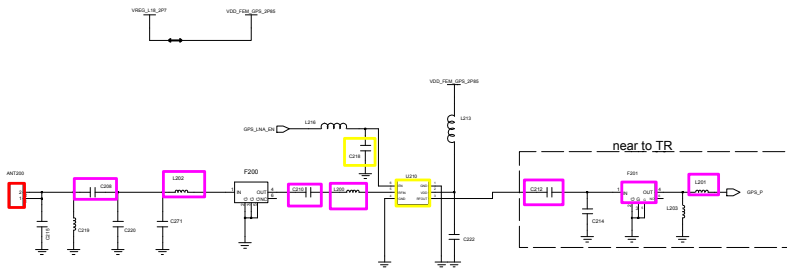

8-3-14. NFC

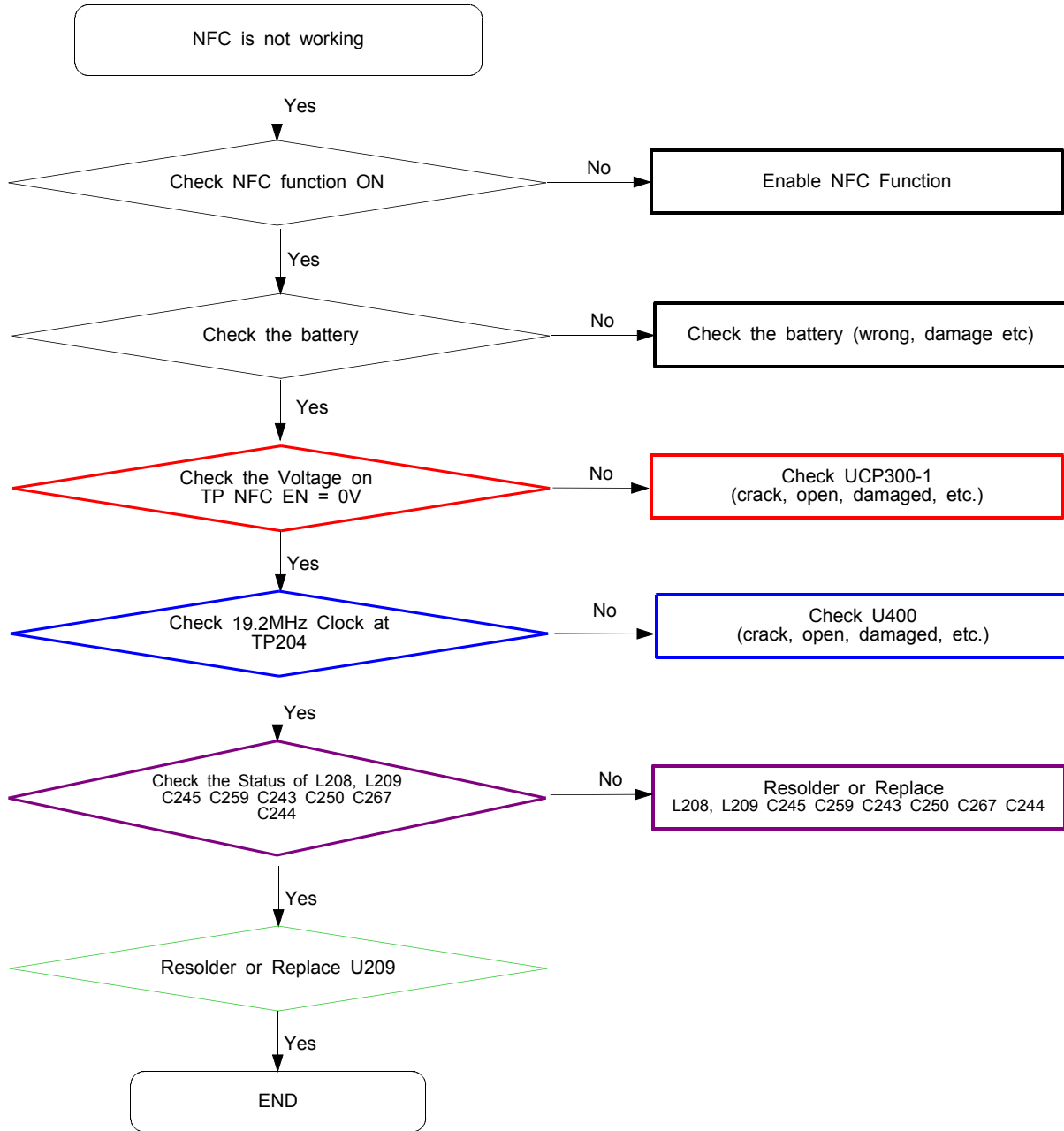

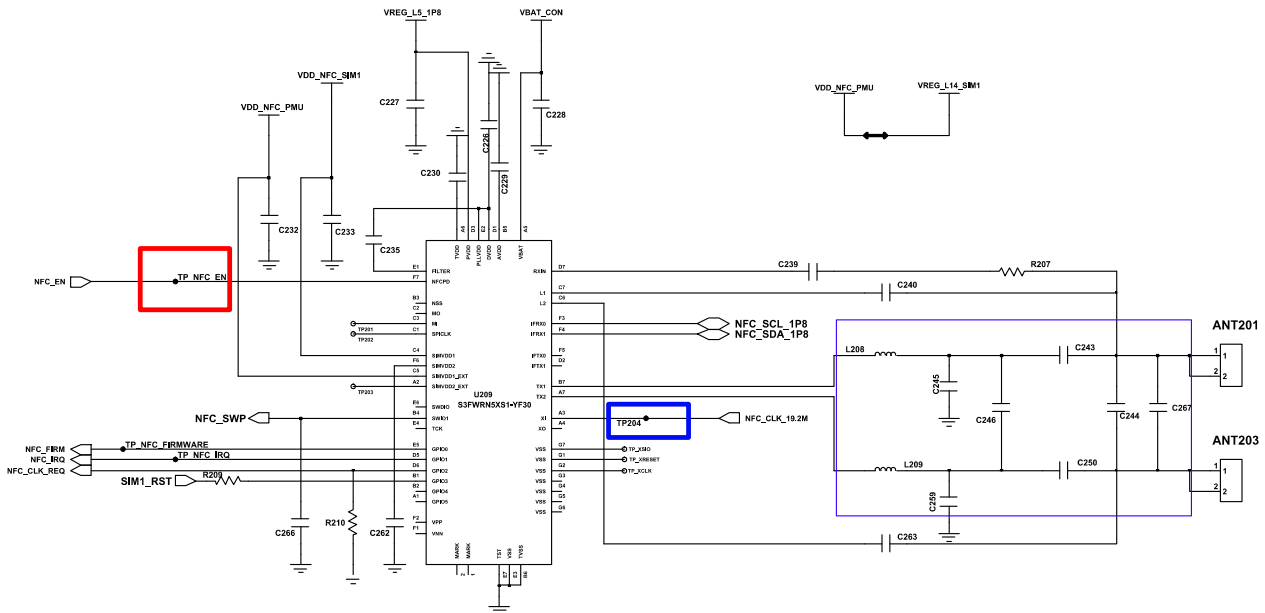

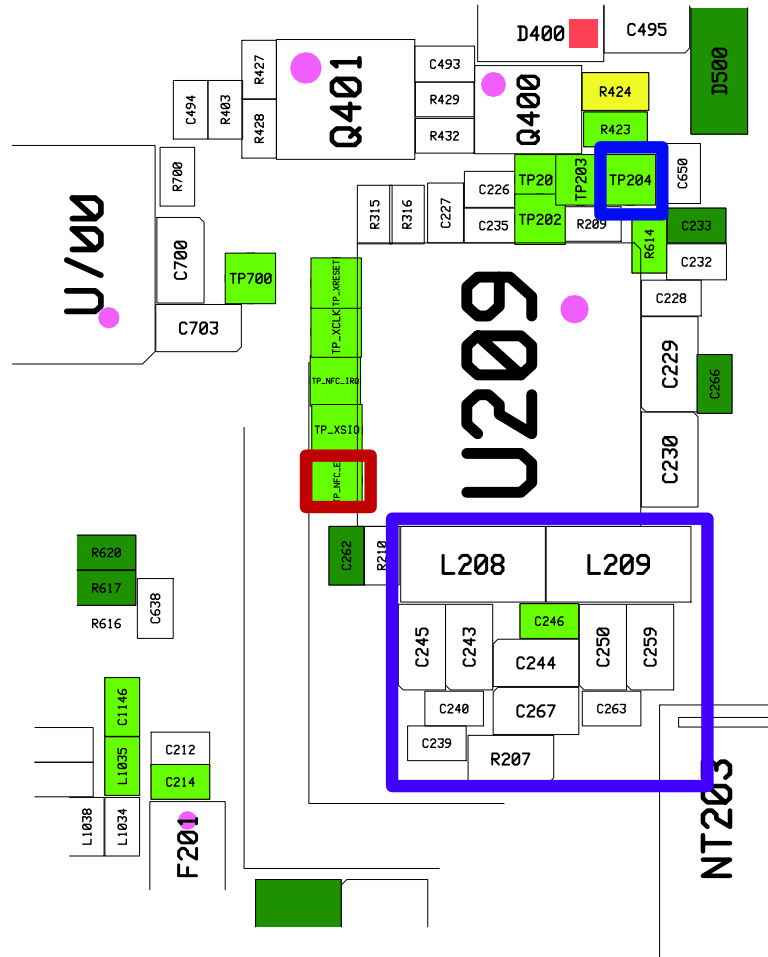

8-3-15. LCD

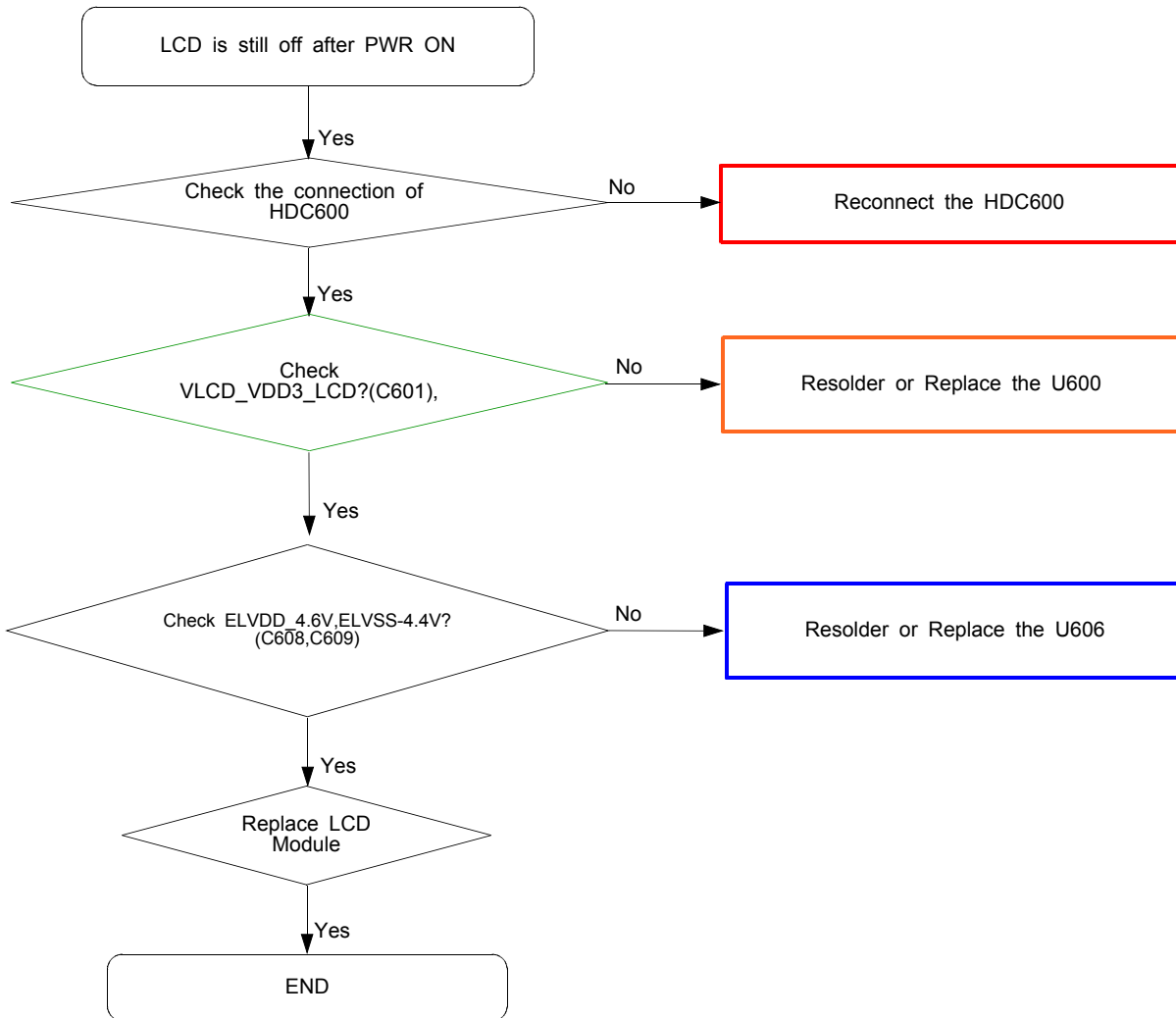

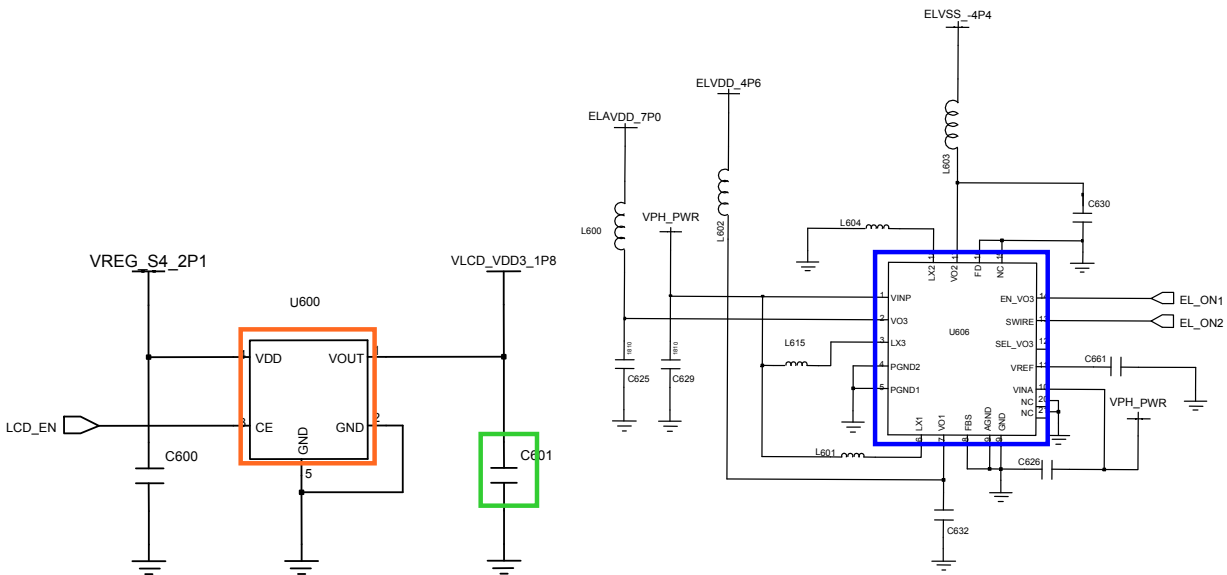
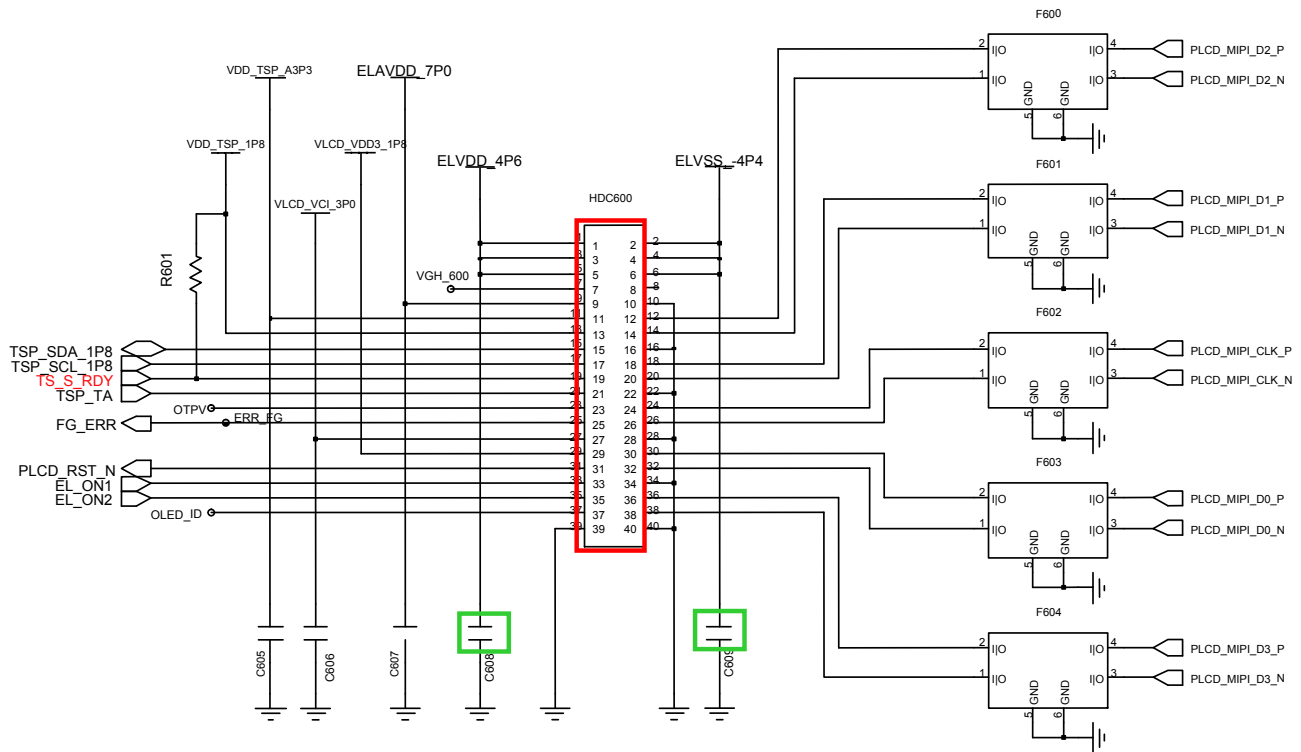

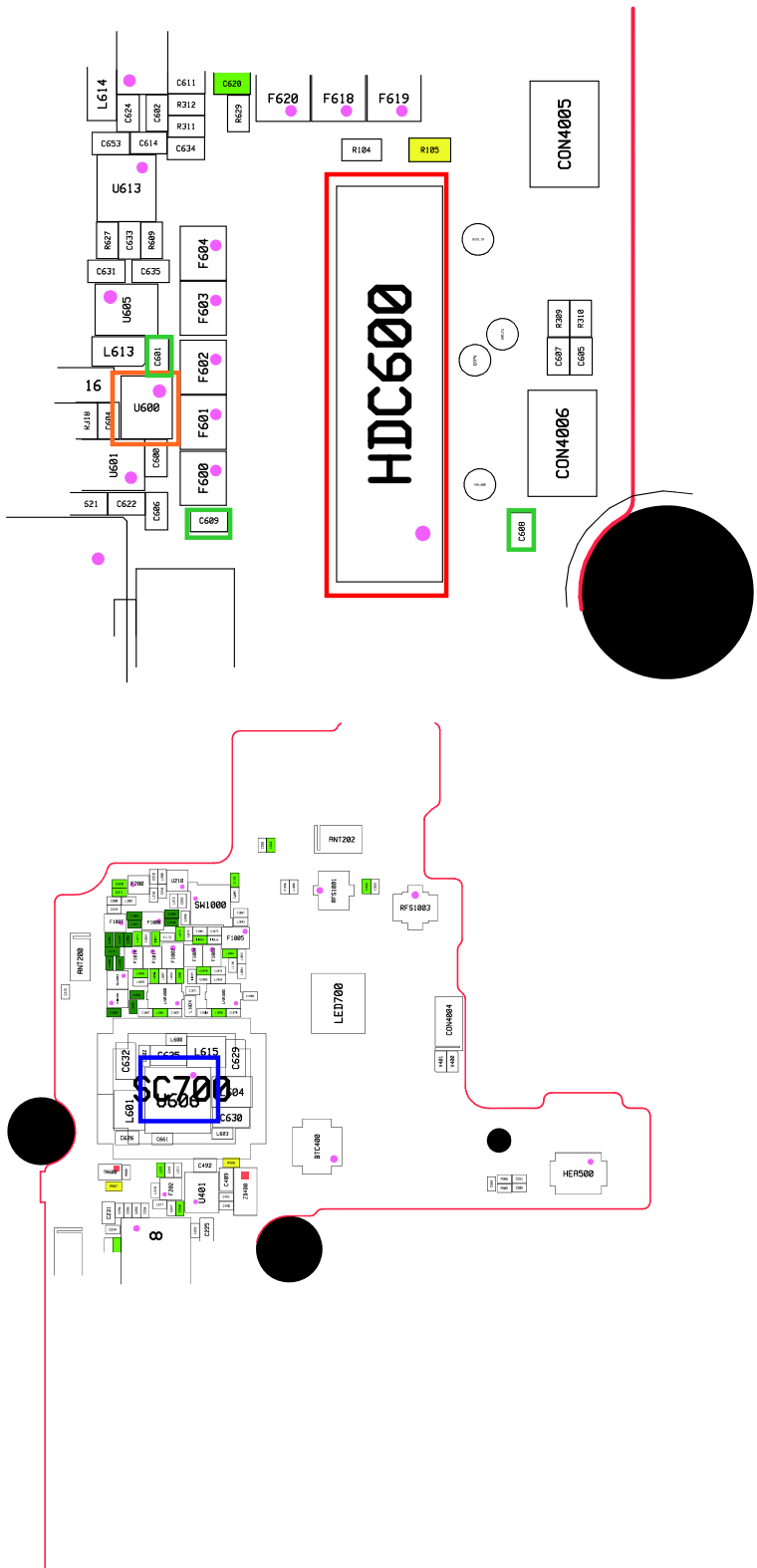

8-3-16. 13M CAM

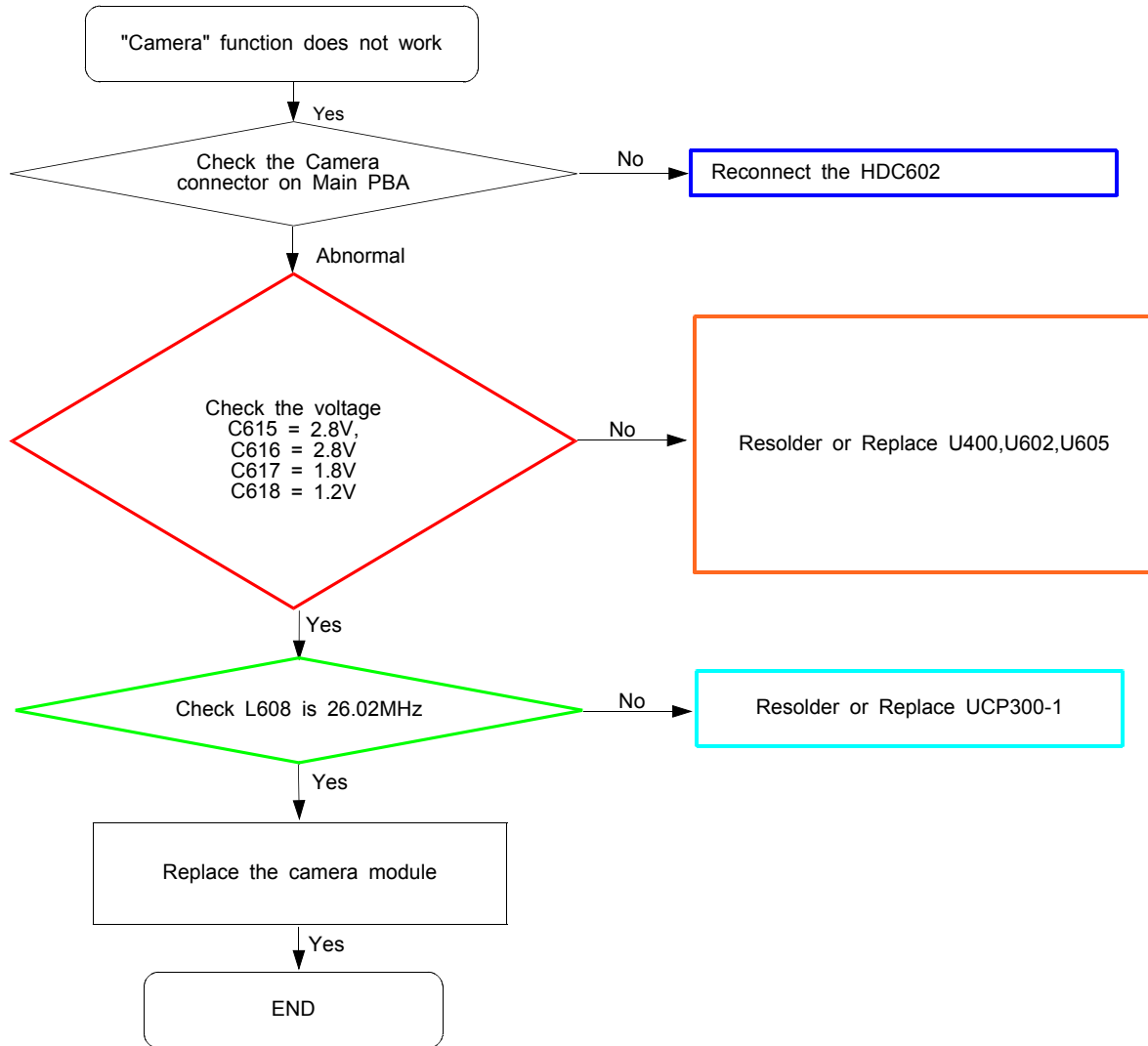

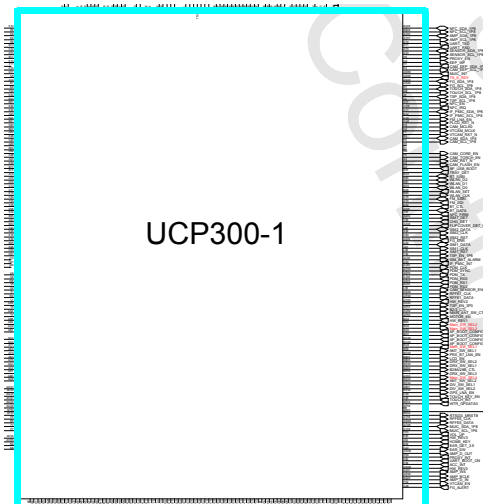
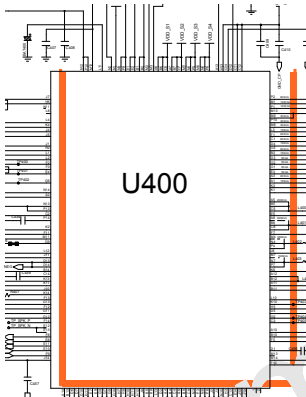
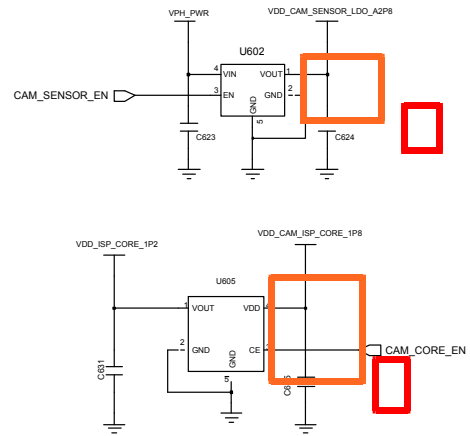
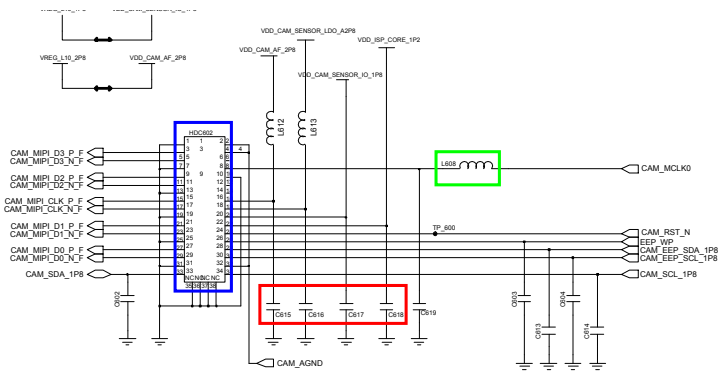

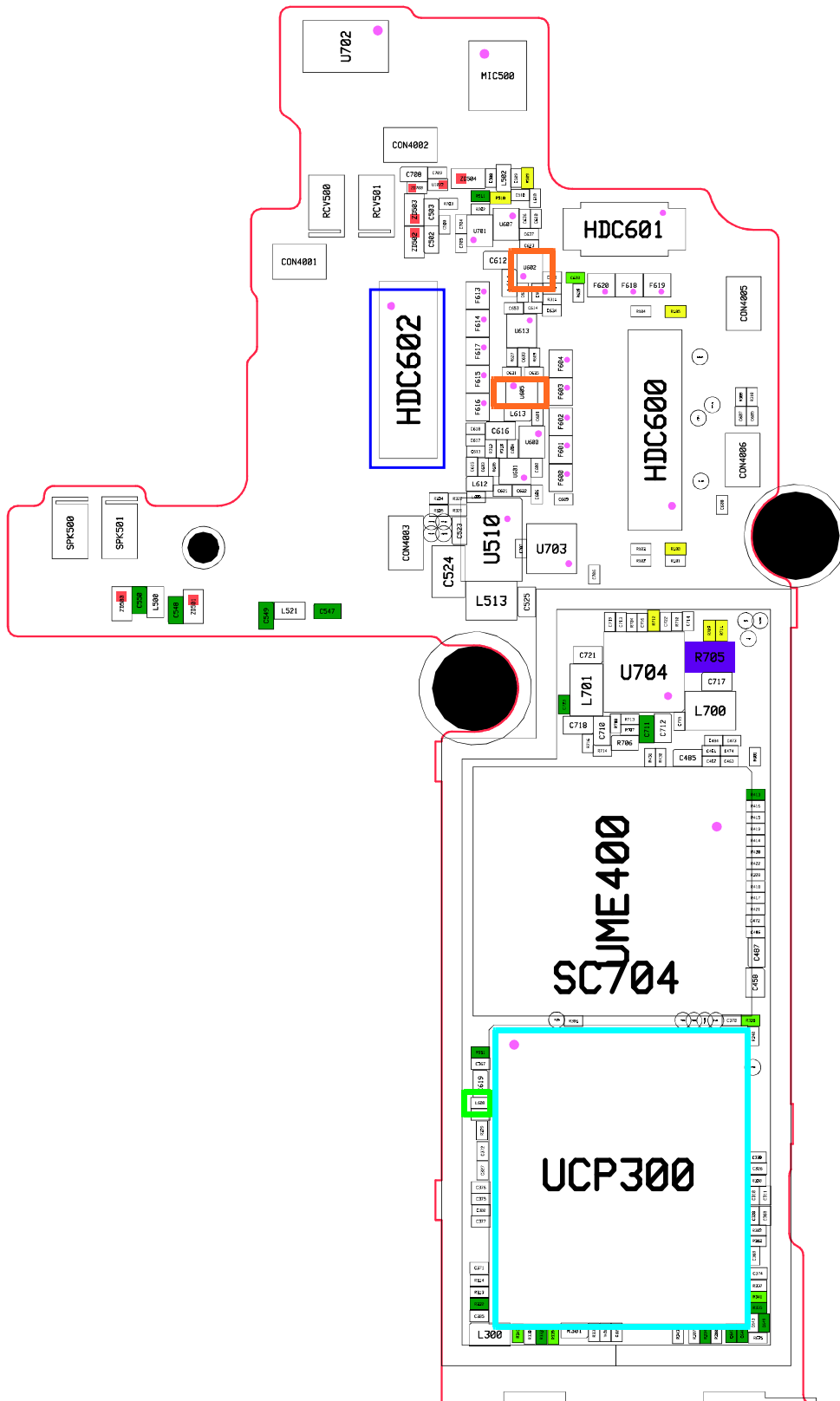

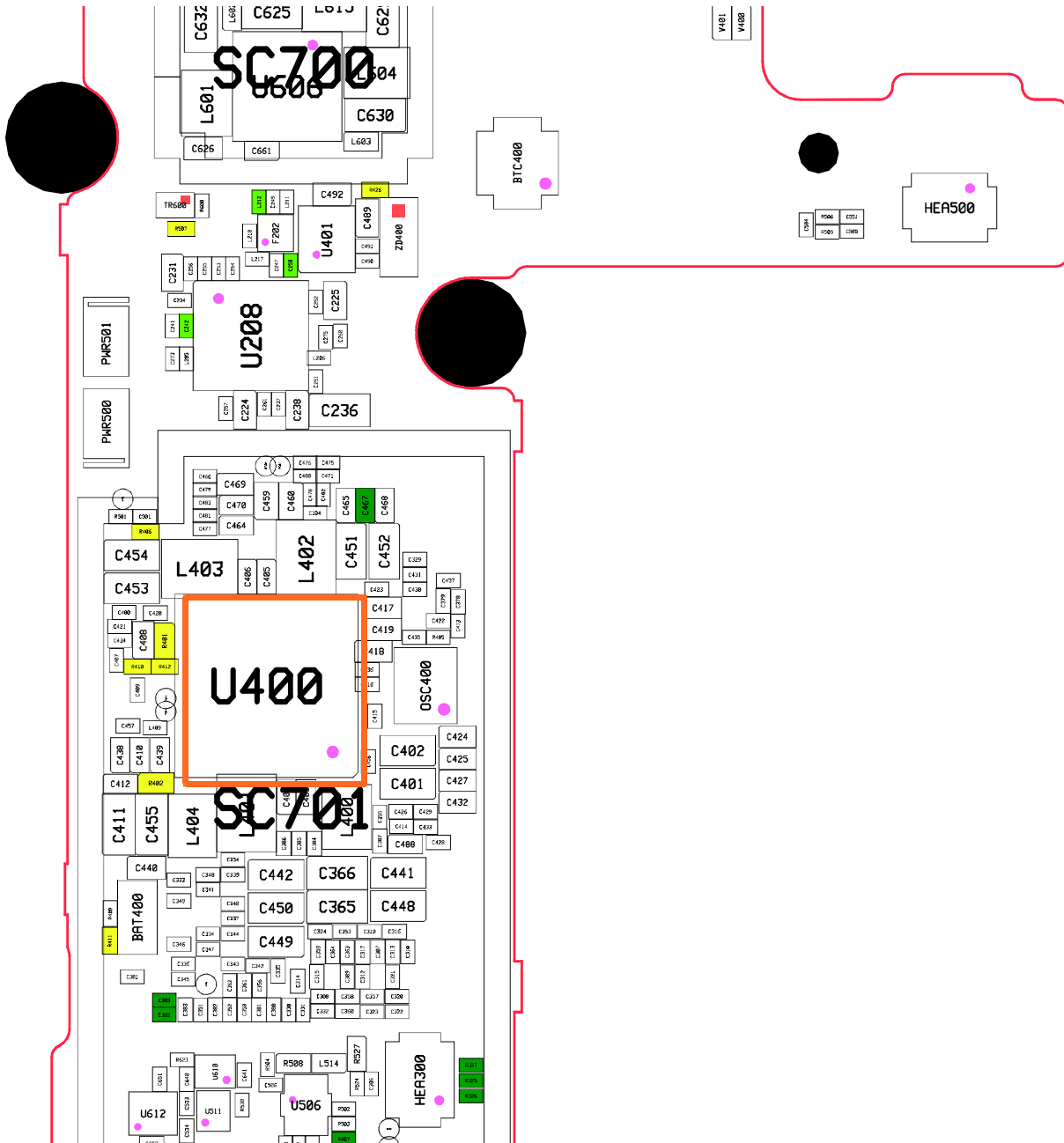

8-3-17. VT CAM

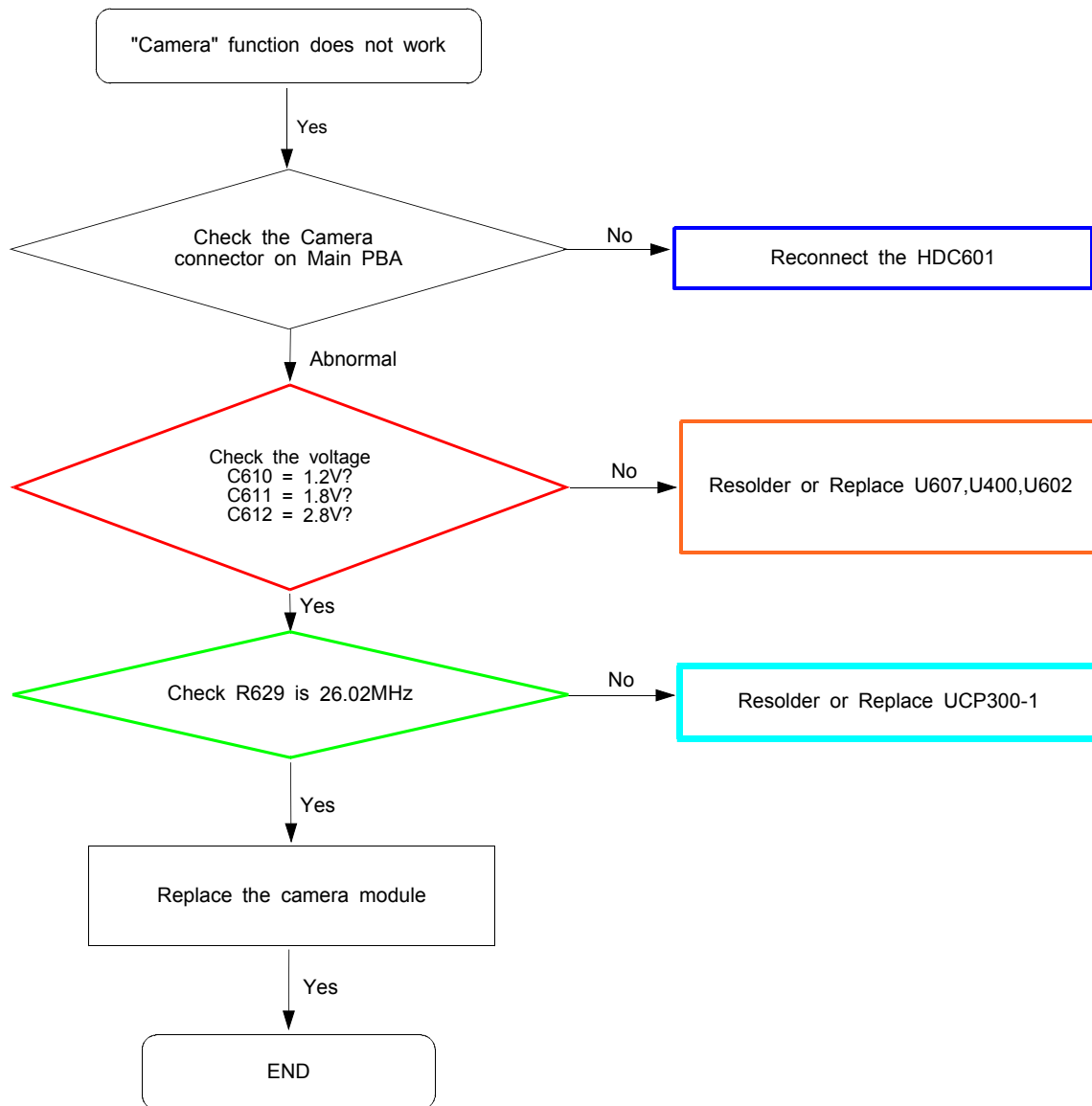

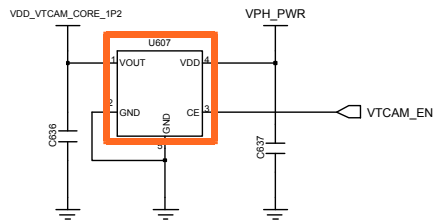
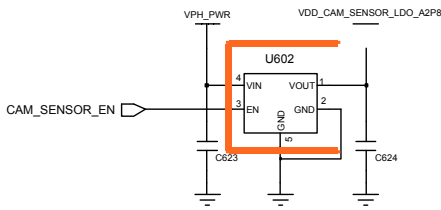
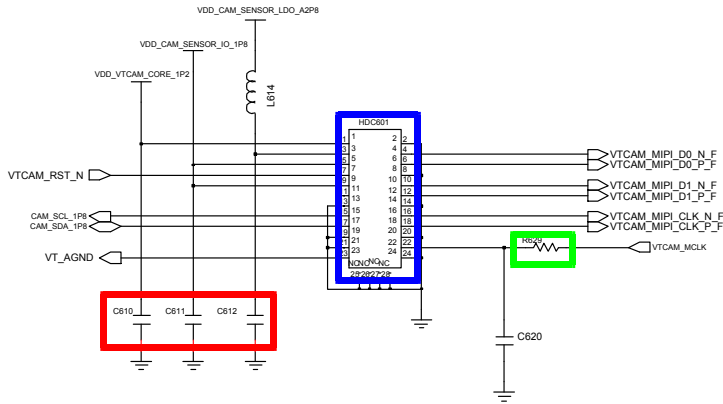

VT CAM LDO

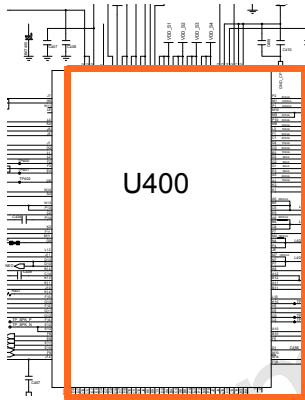

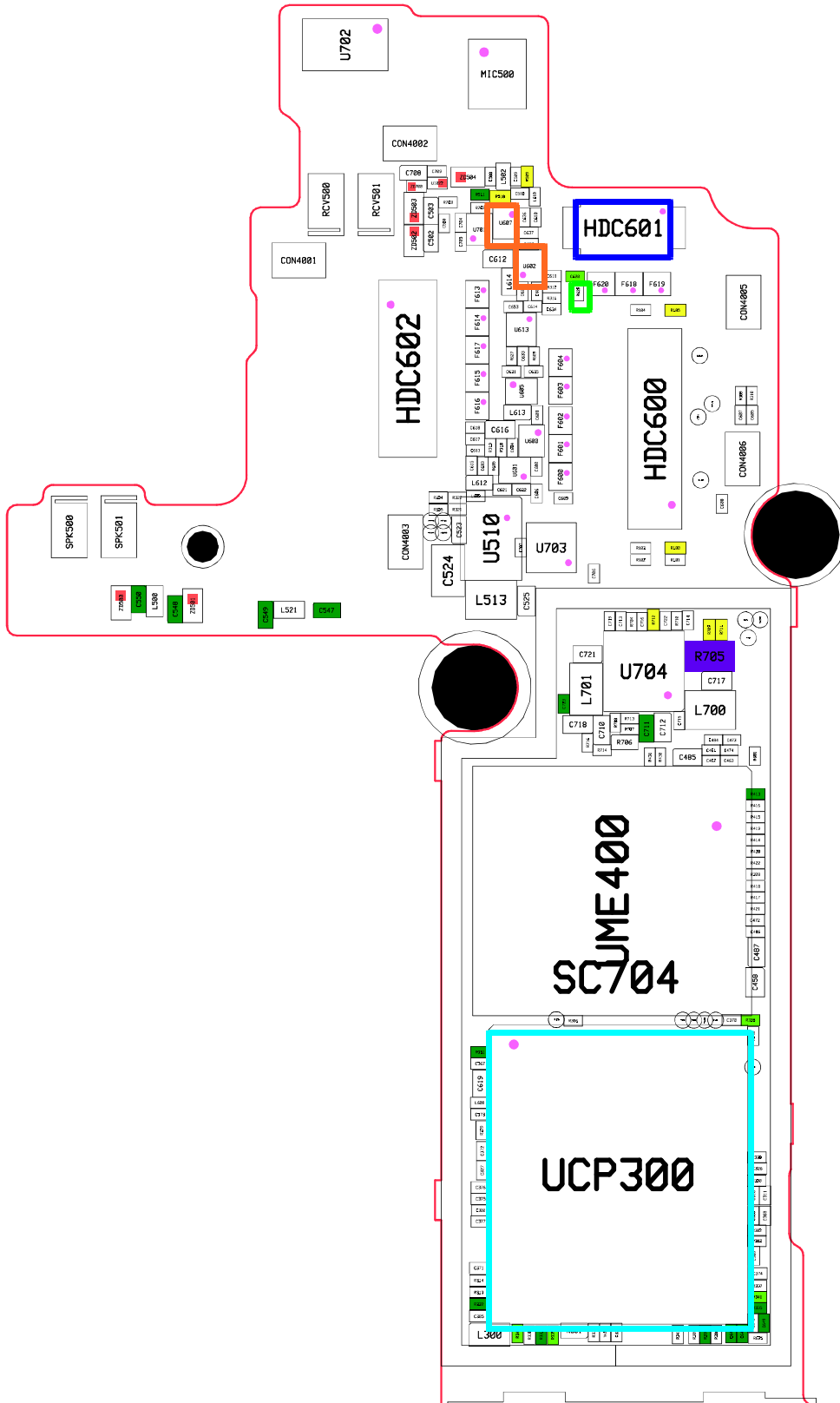

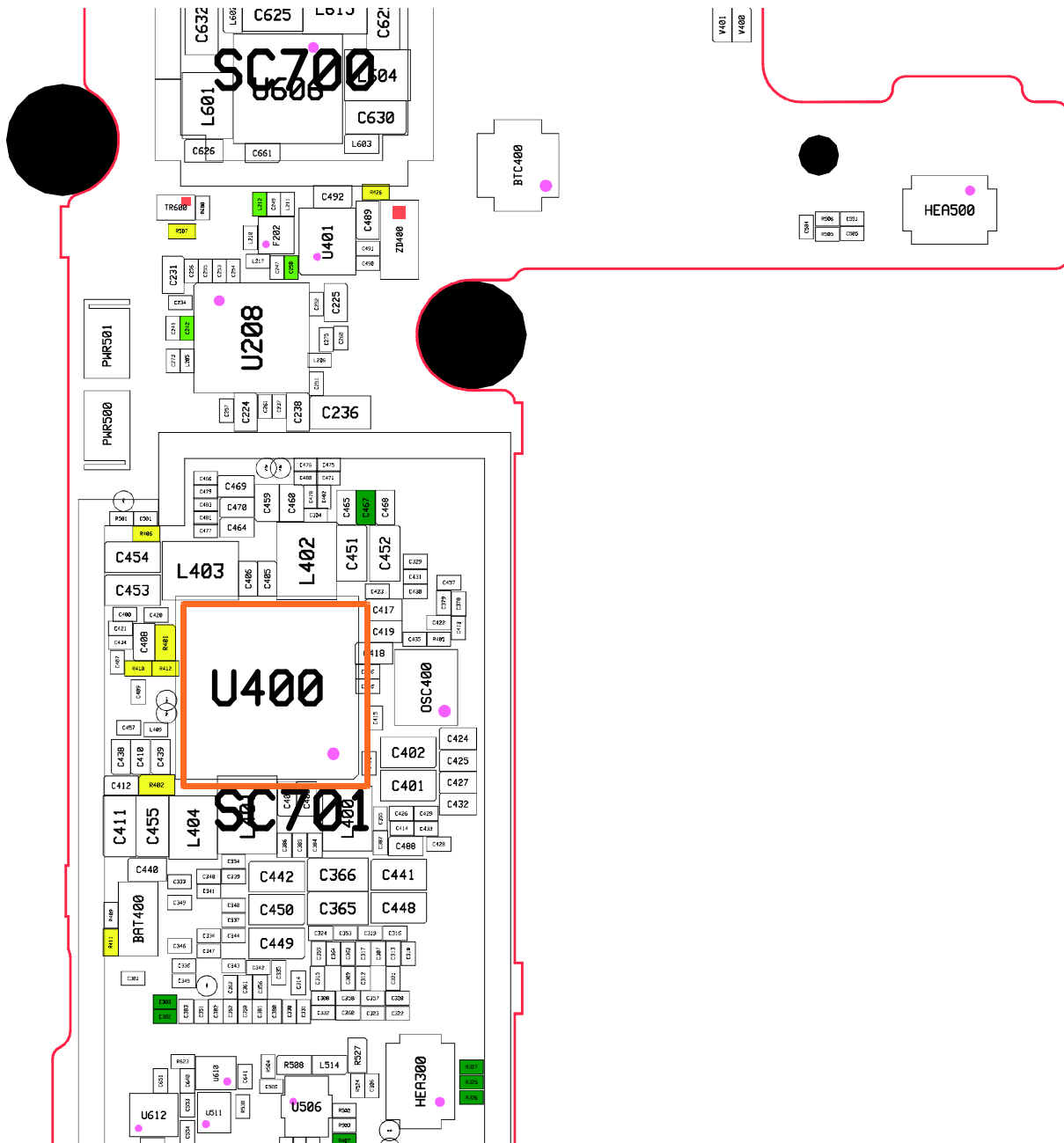

8-3-18. Ear Jack

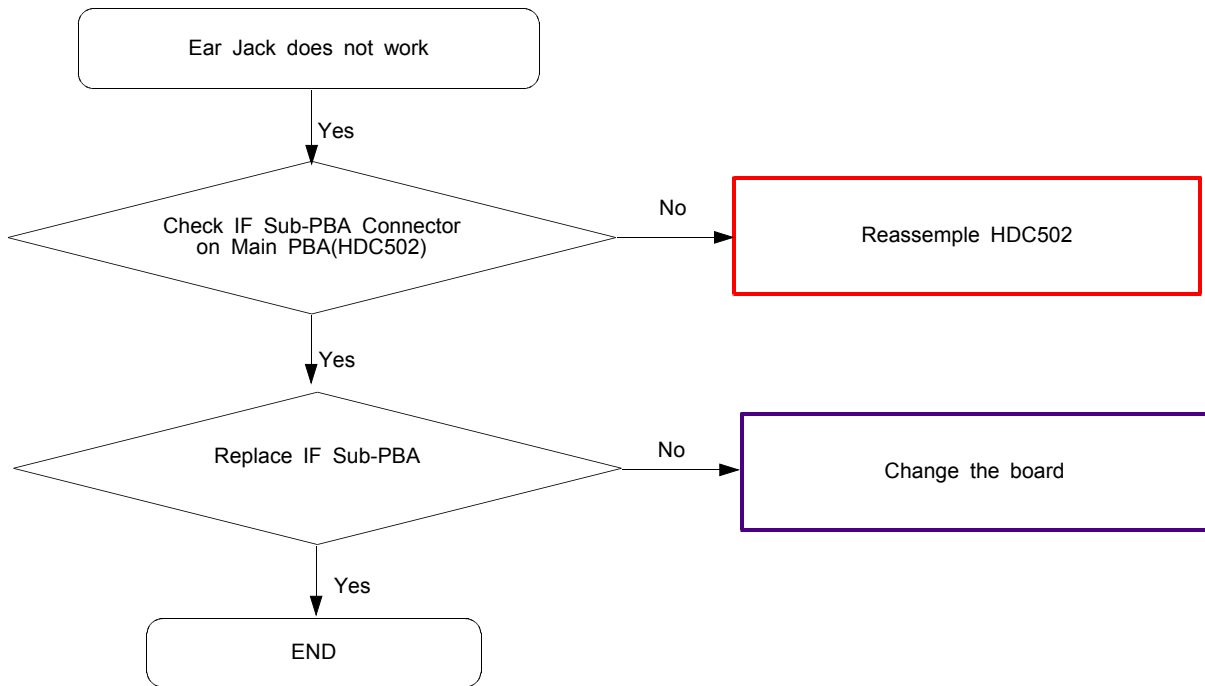

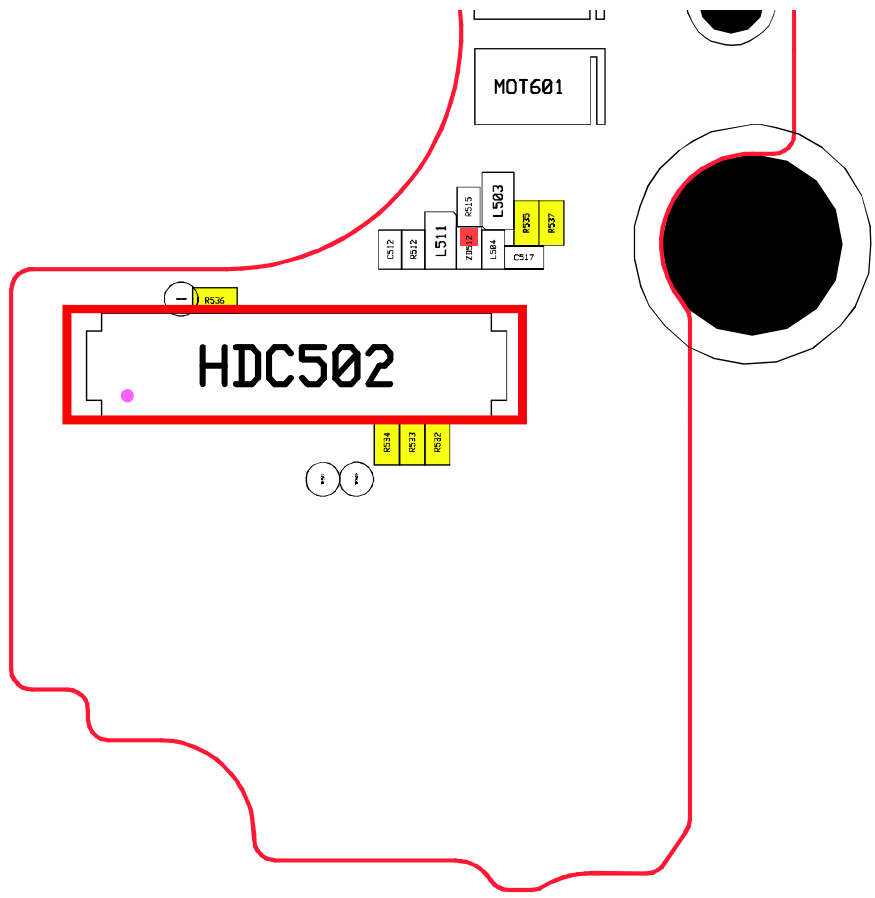
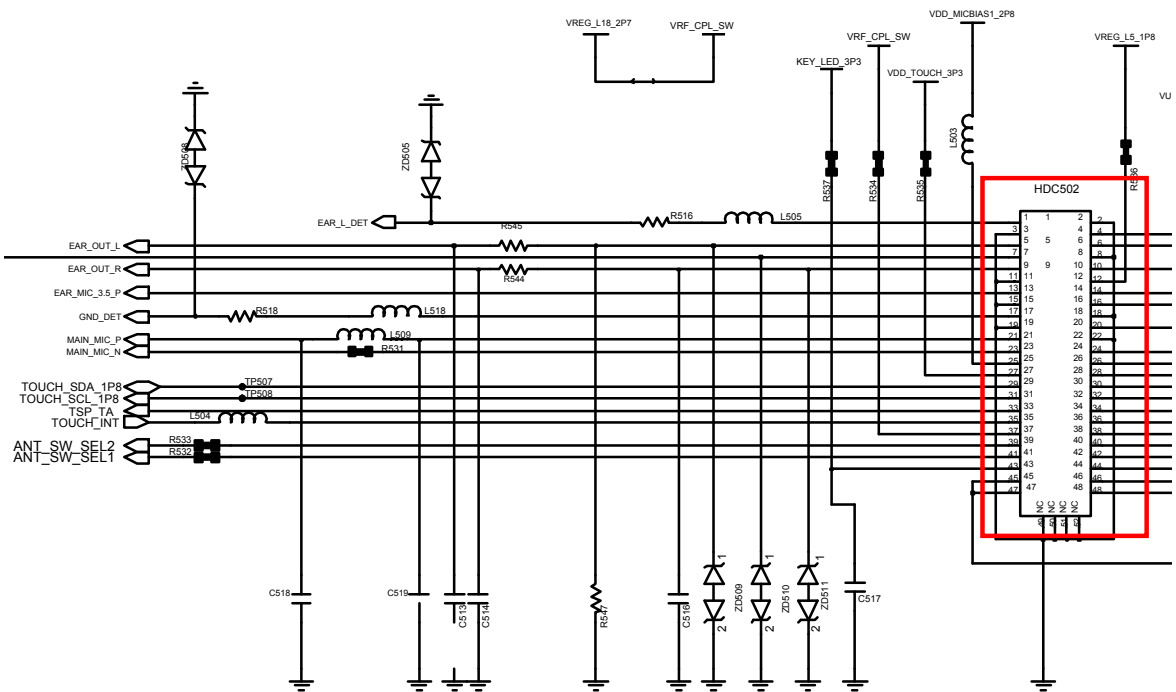

50107051 . 8-45

8-3-19. TSP

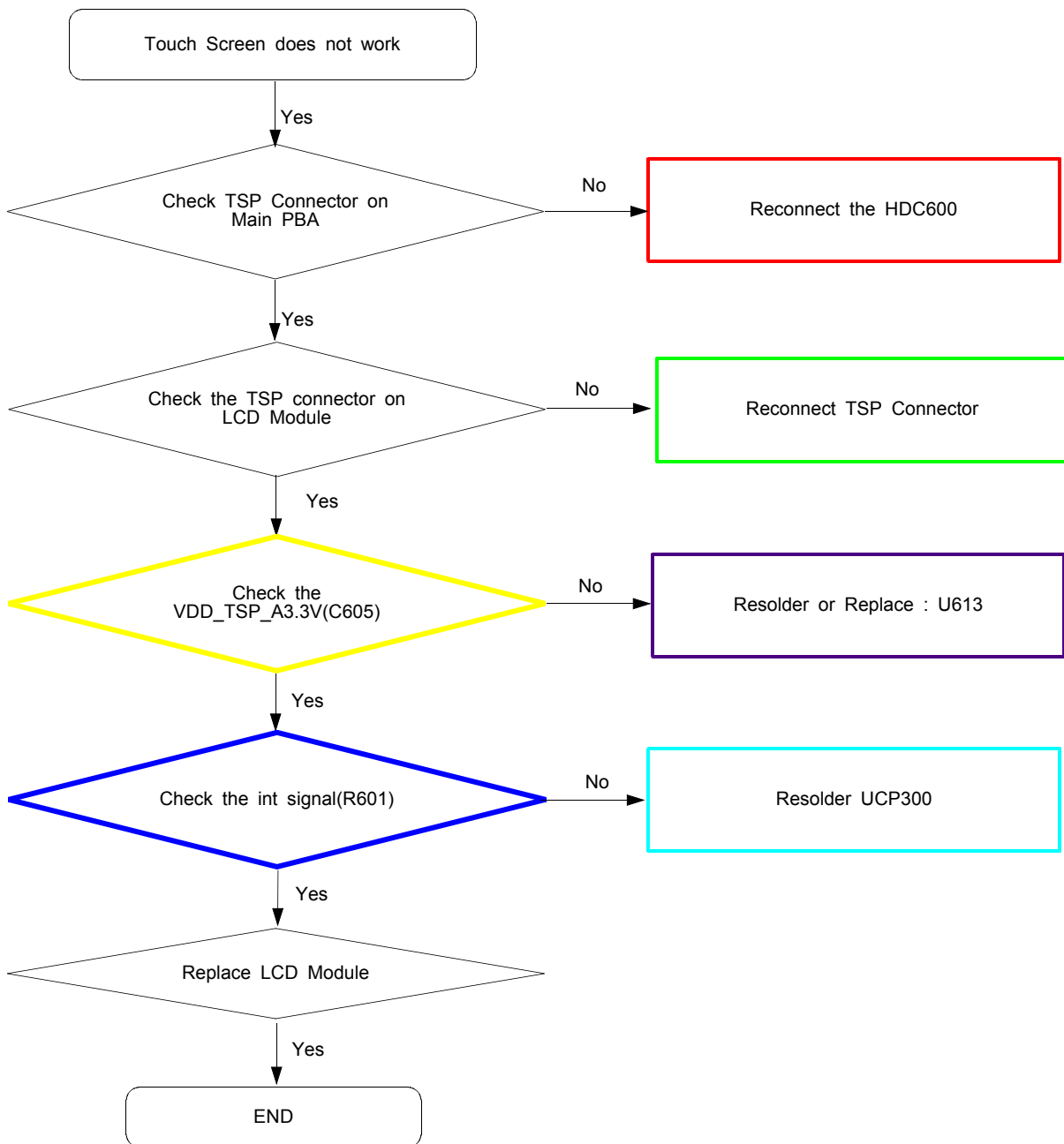

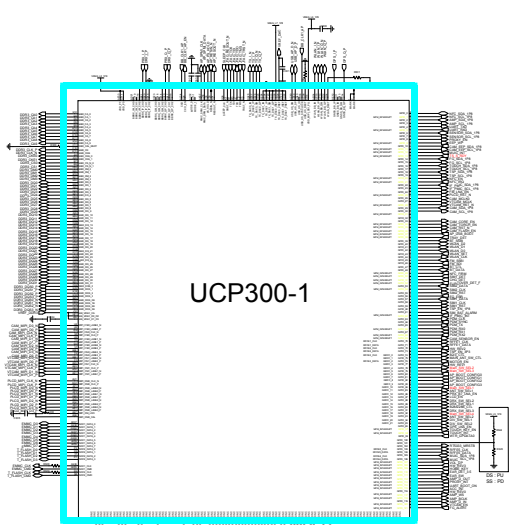
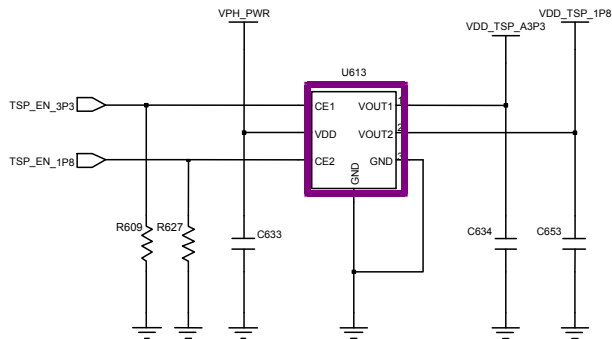
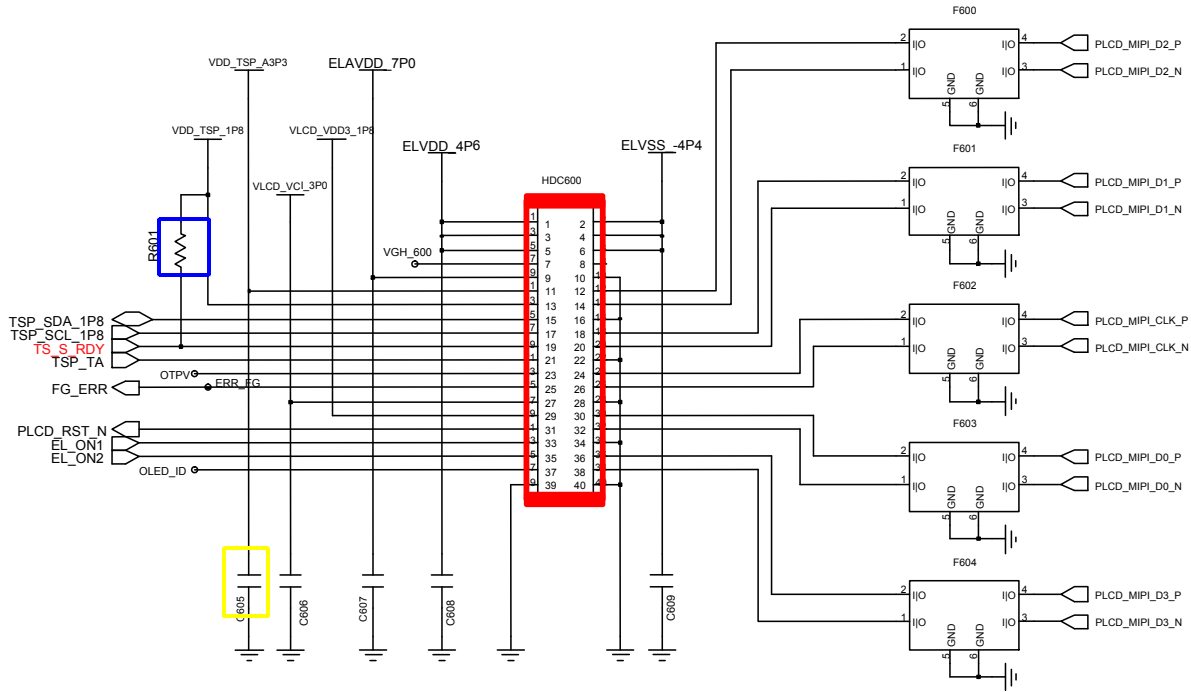

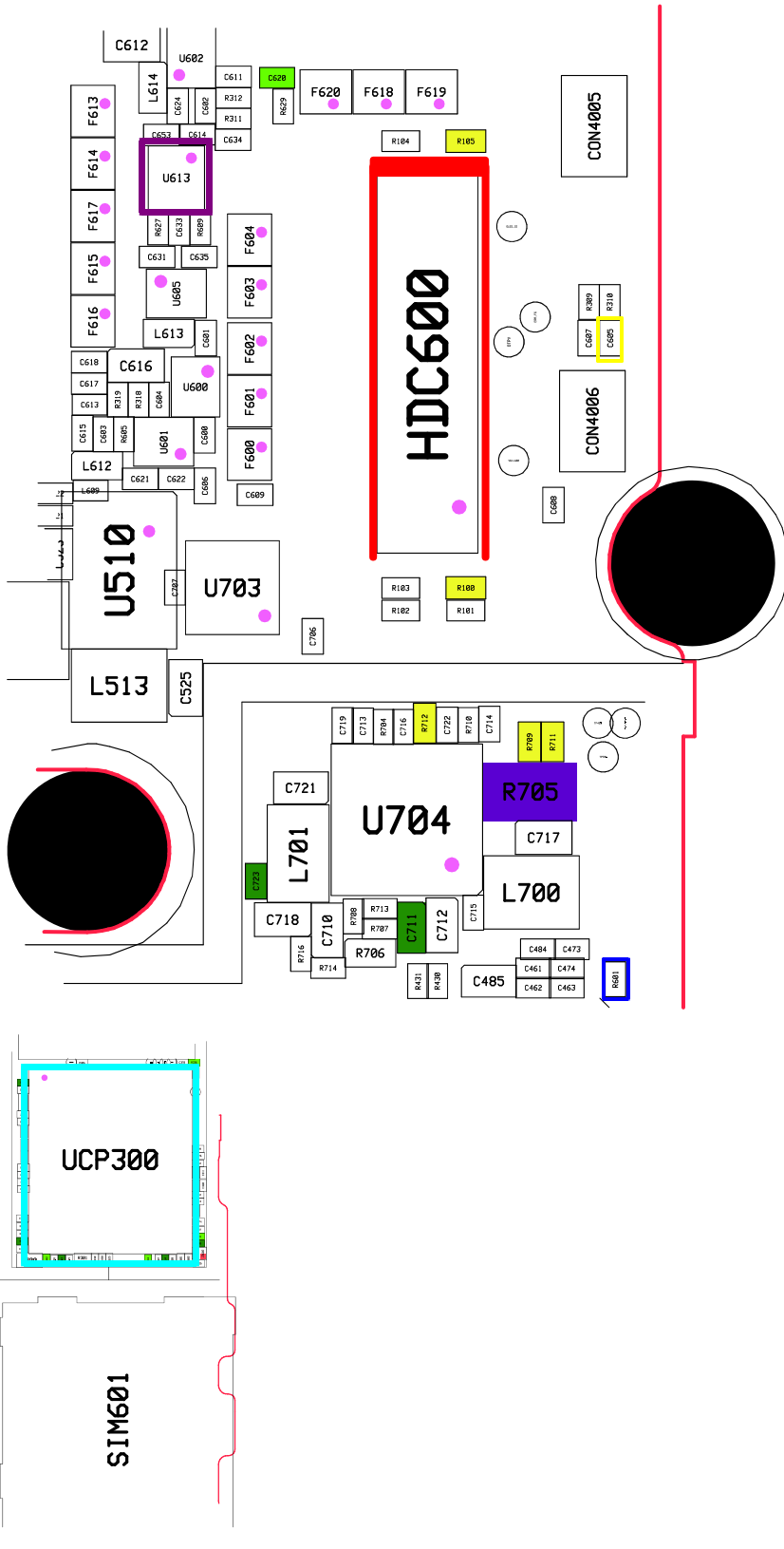

8-3-20. Motor

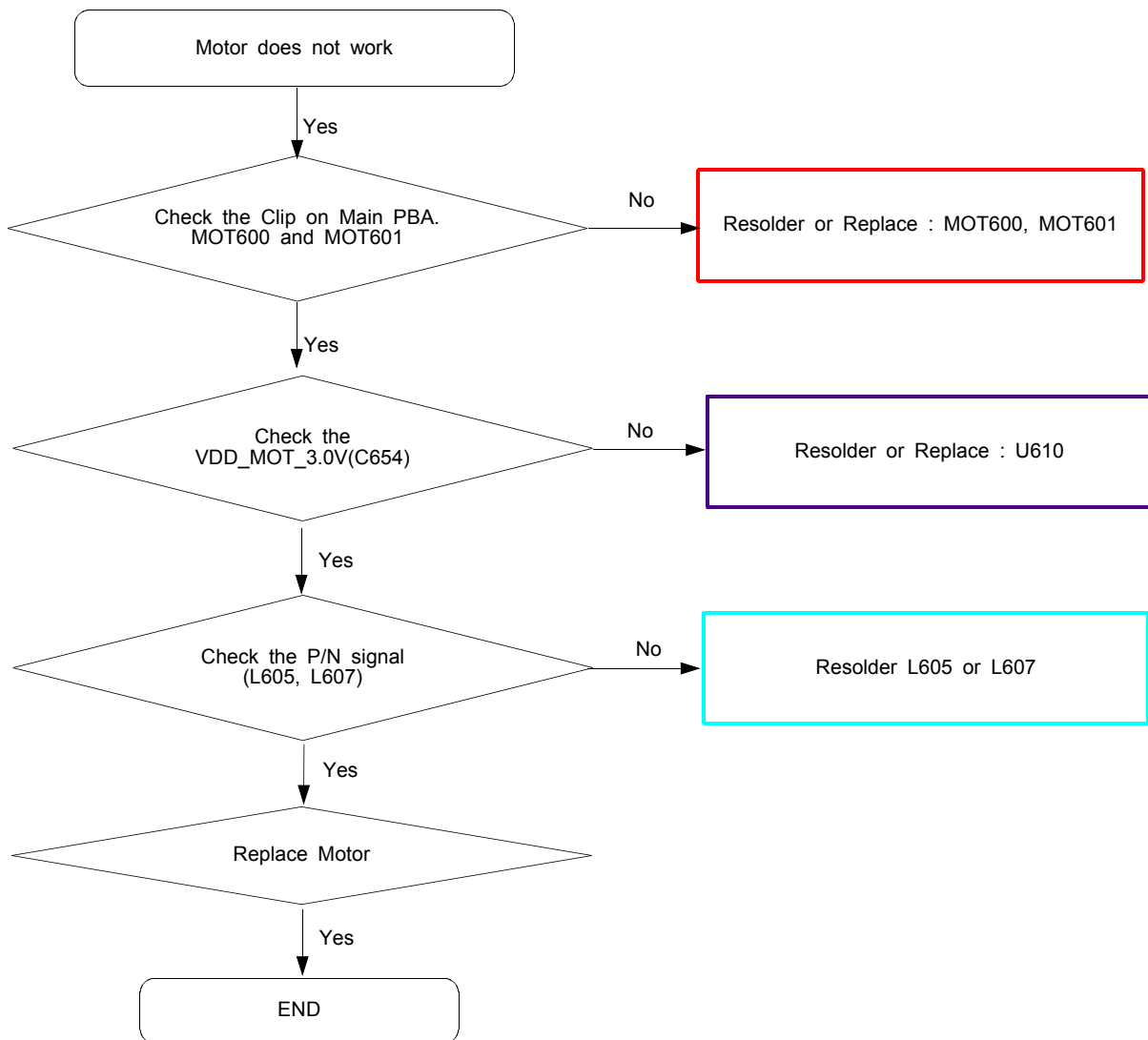

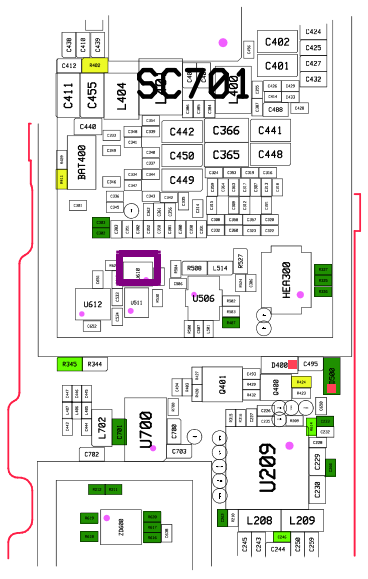
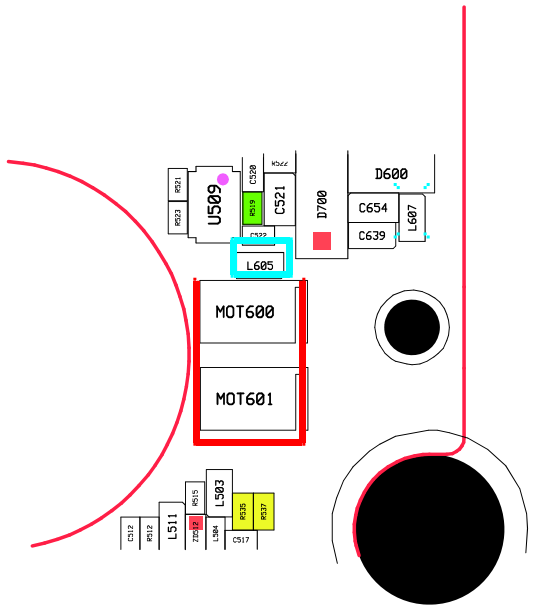
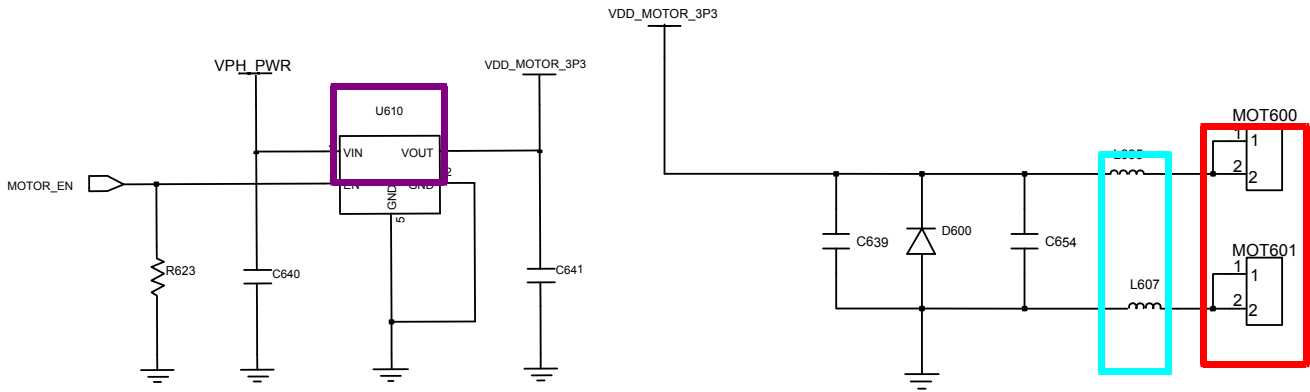

8-3-21. GSM850 / WCDMA B5 / LTE5 RX

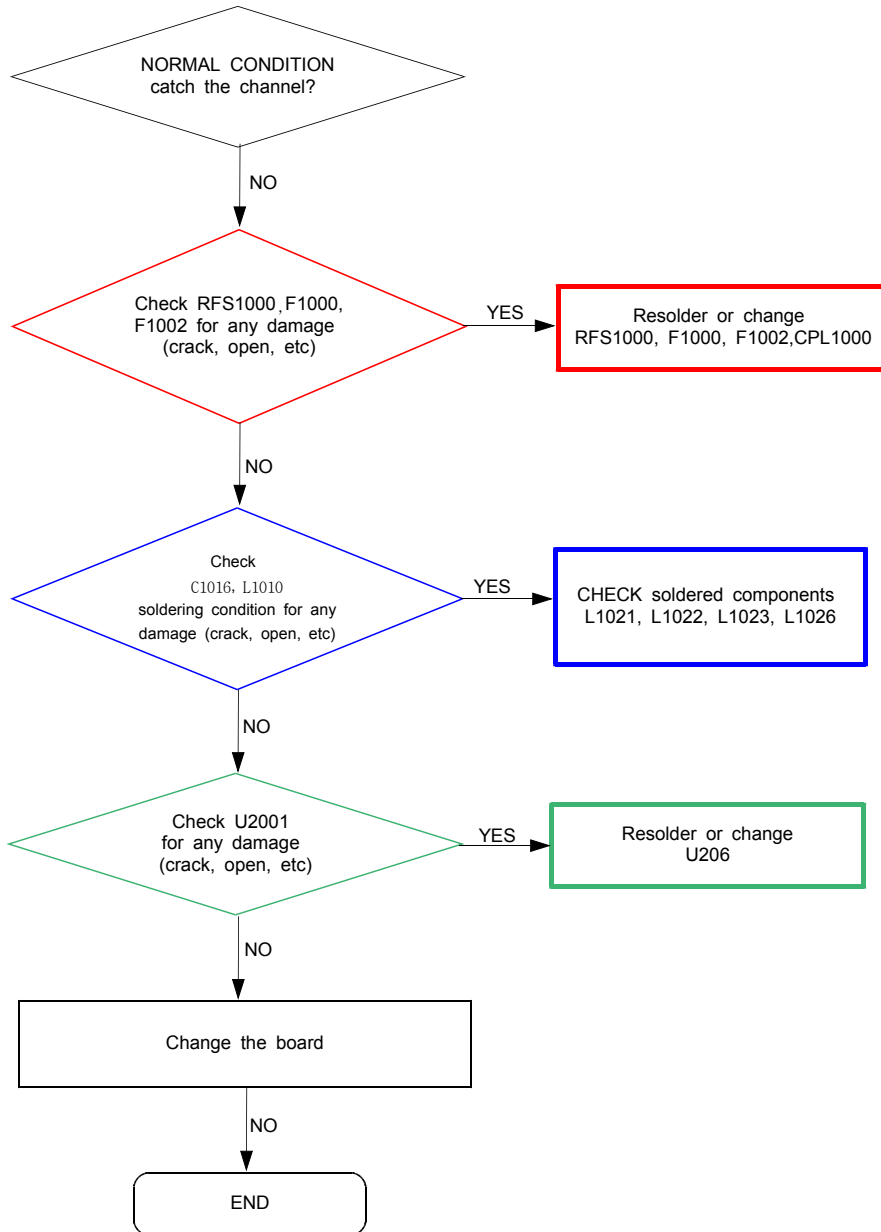

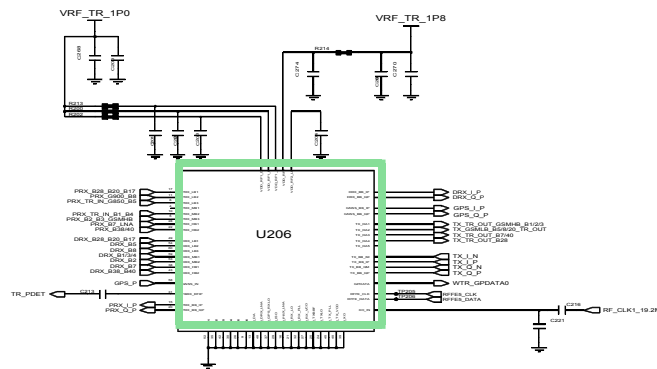
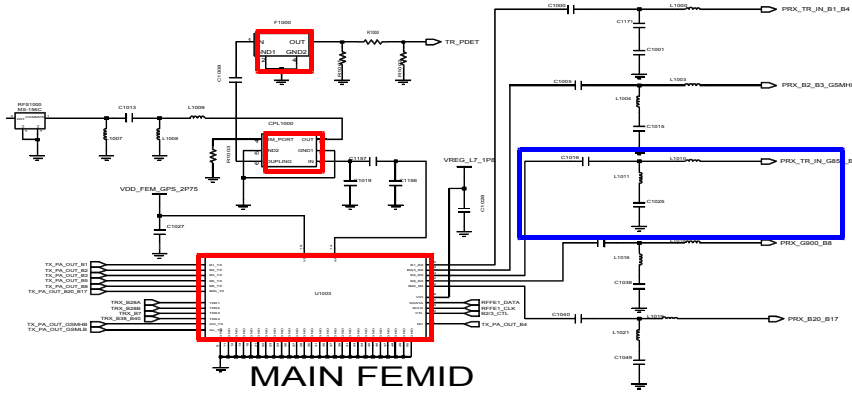

RF Transceiver



8-3-22. GSM900 / WCDMA B8 / LTE8 RX

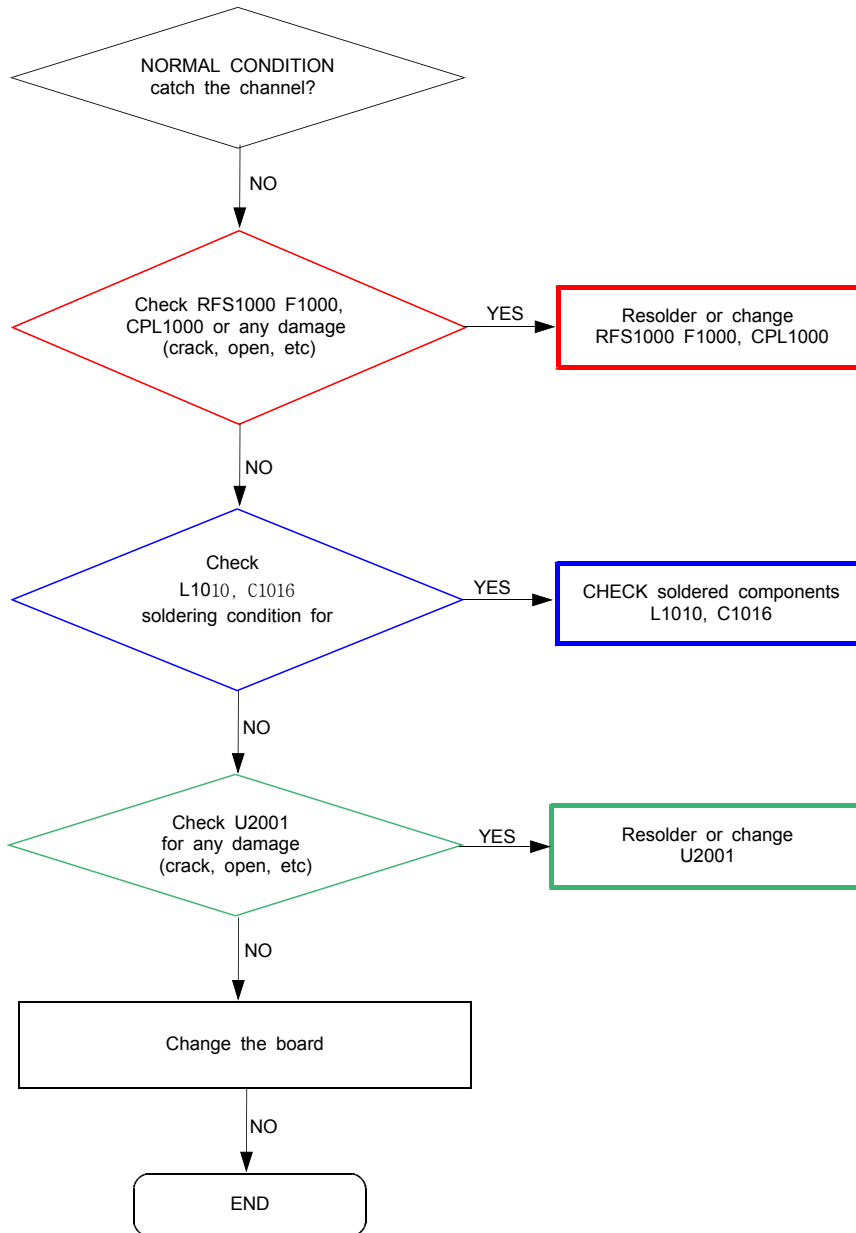

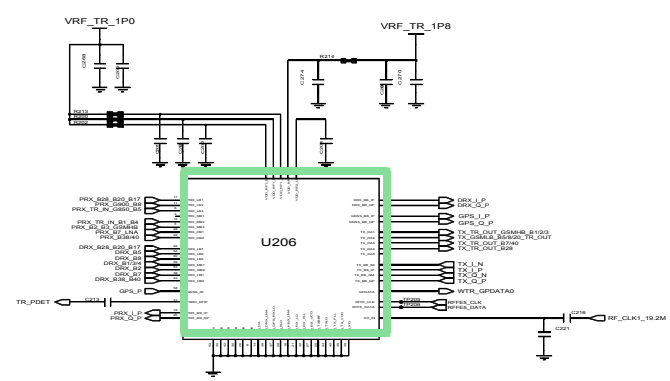
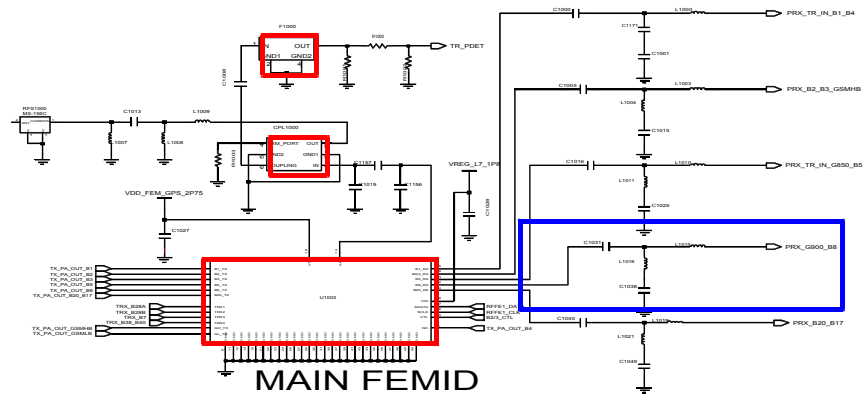

RF Transceiver



8-3-23. GSM1800 / GSM1900 B2 / B3 RX

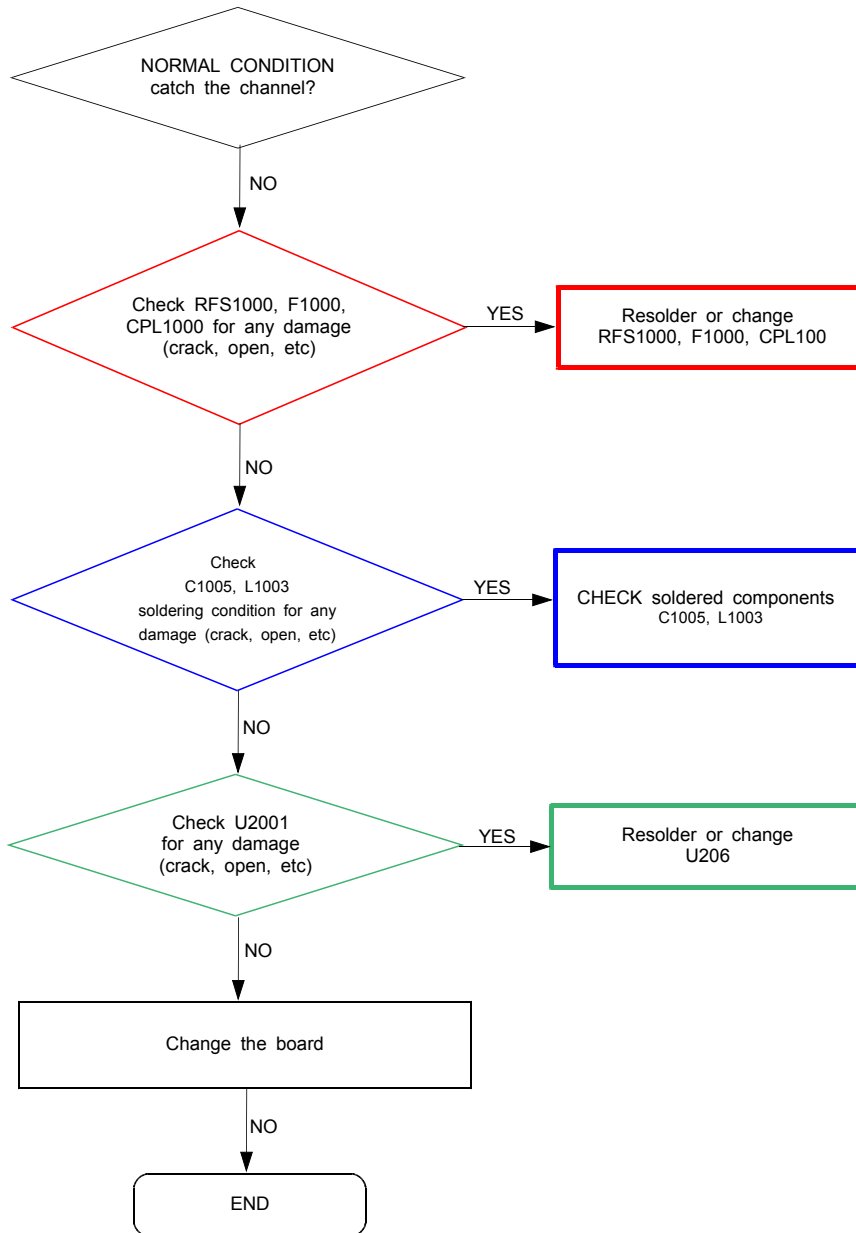

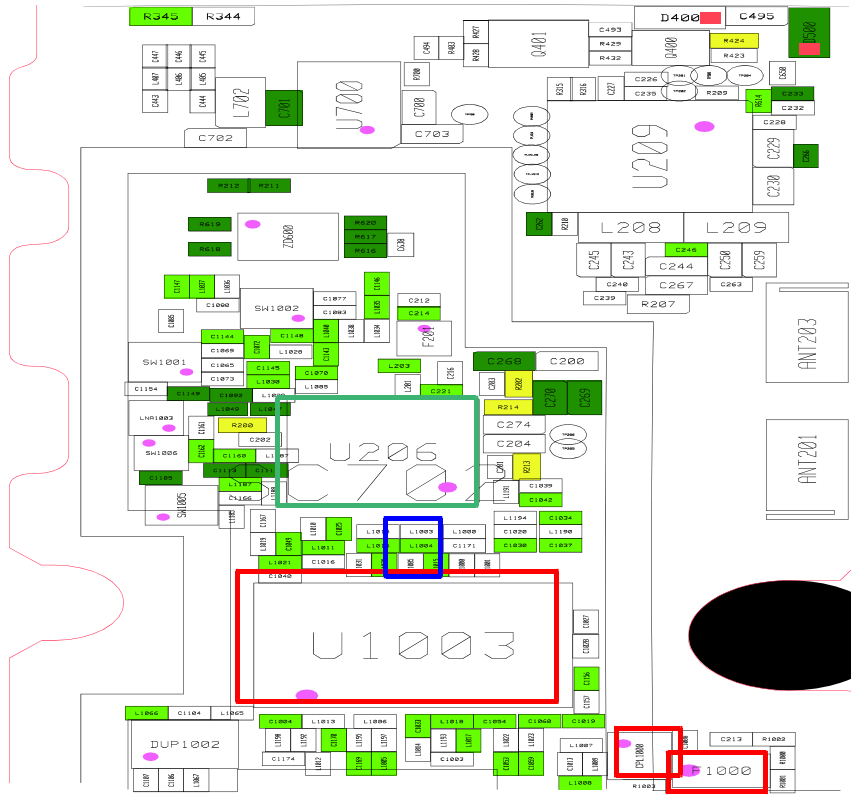
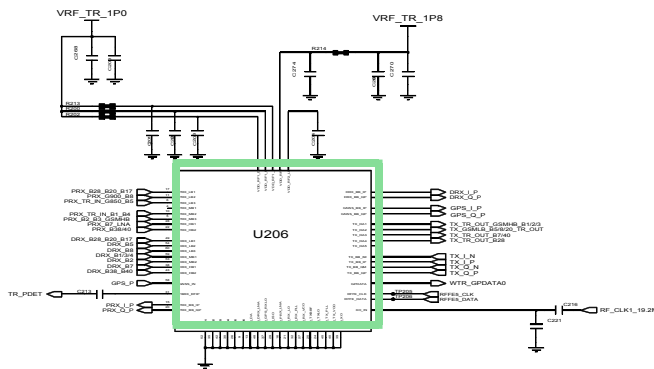
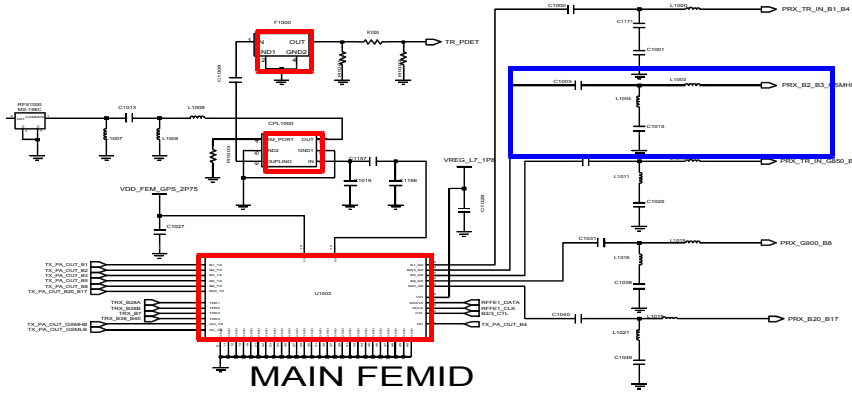

8-3-24. WCDMA B1 / LTE1 RX

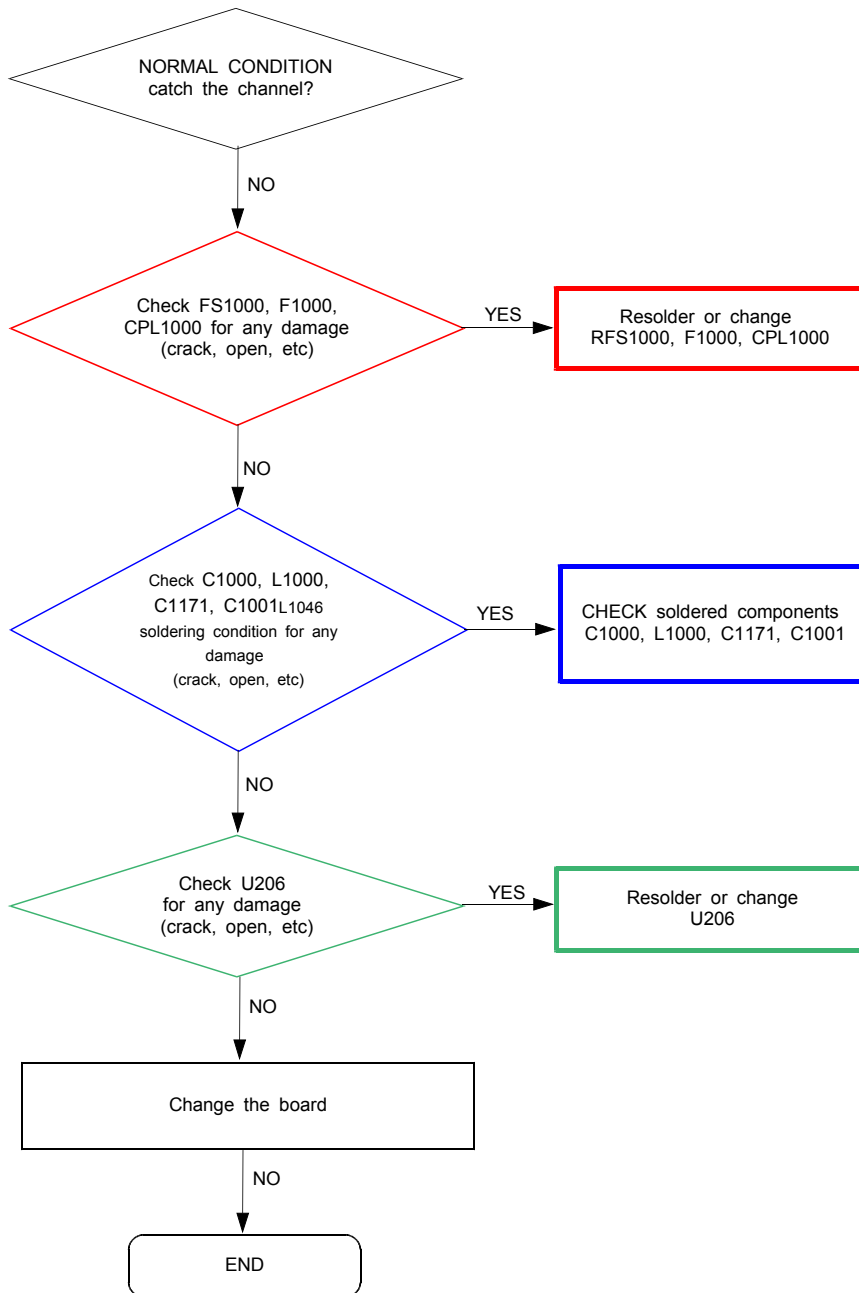

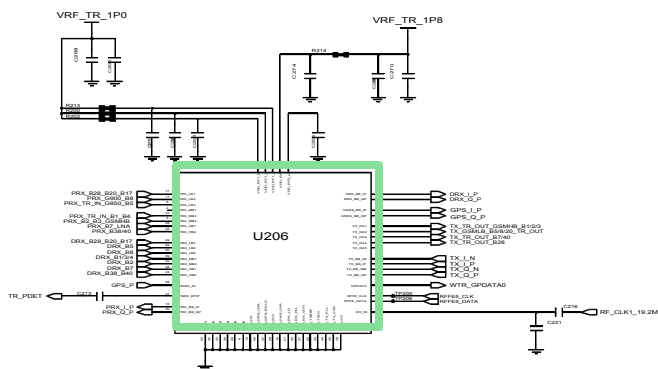
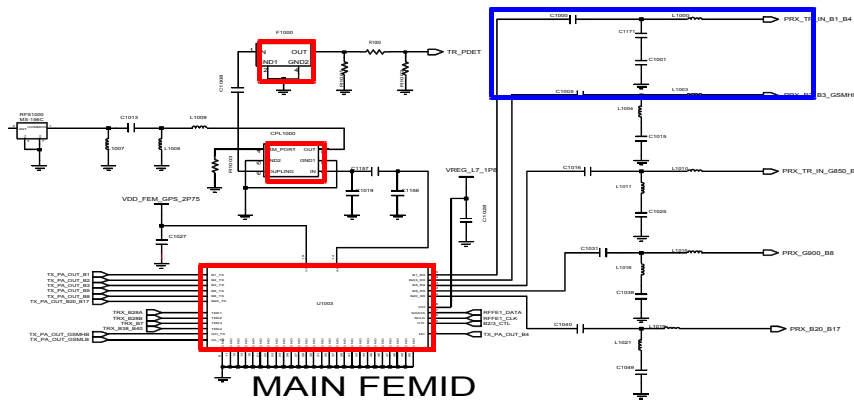

RF Transceiver



8-3-25. LTE7 RX

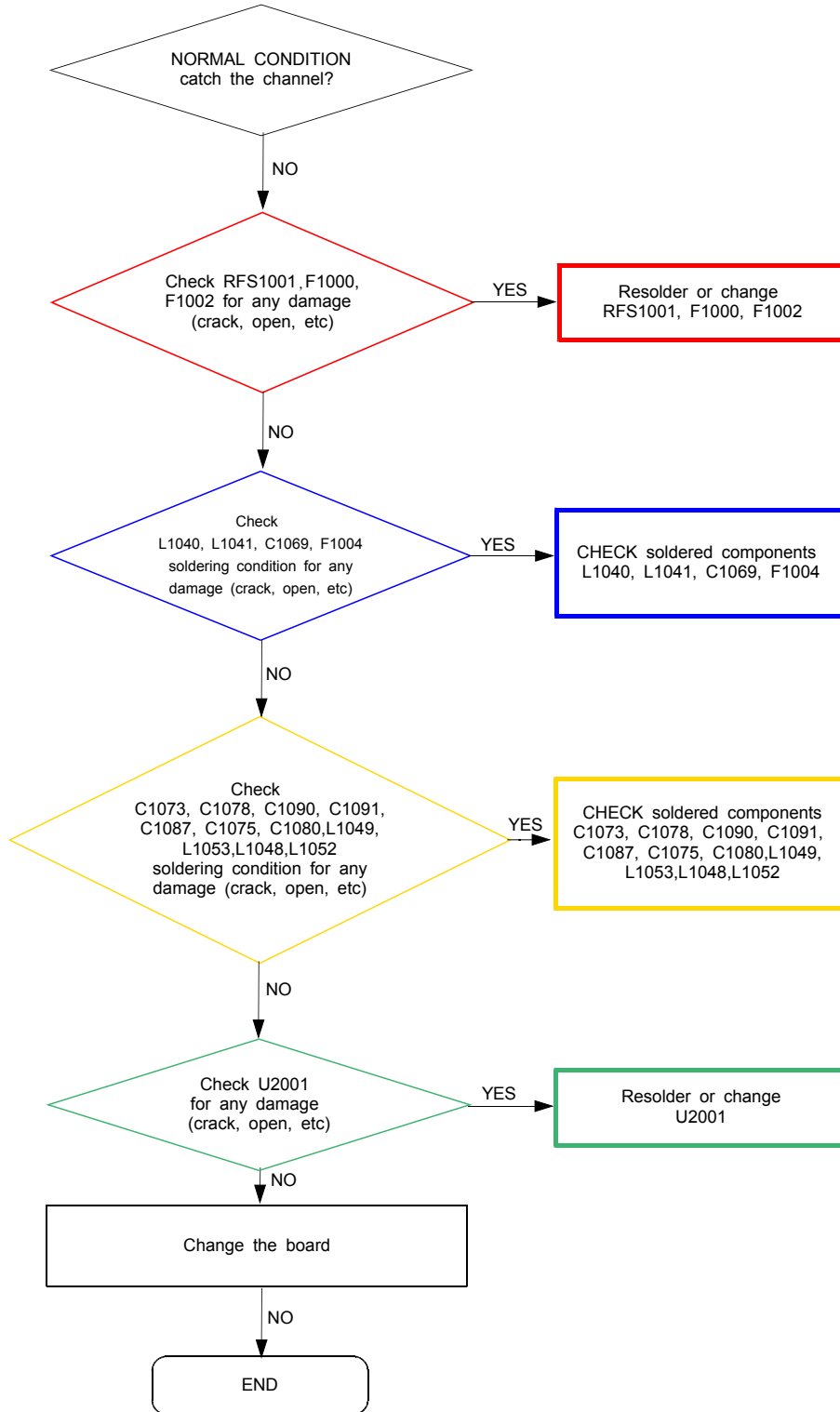

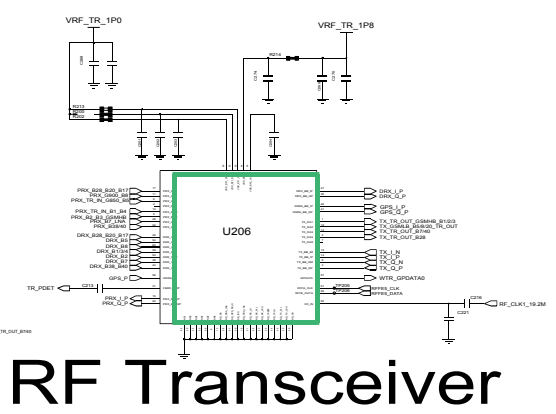
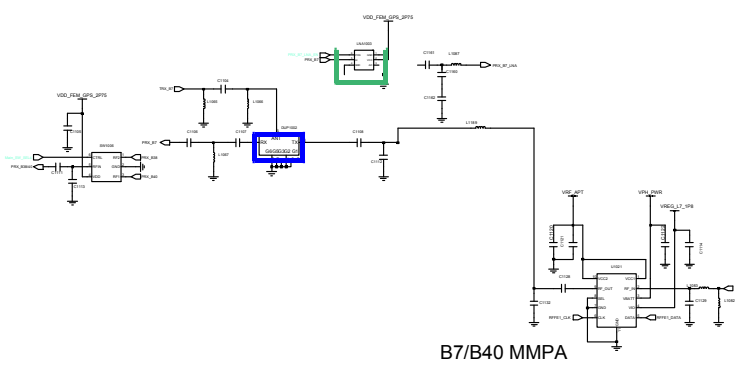
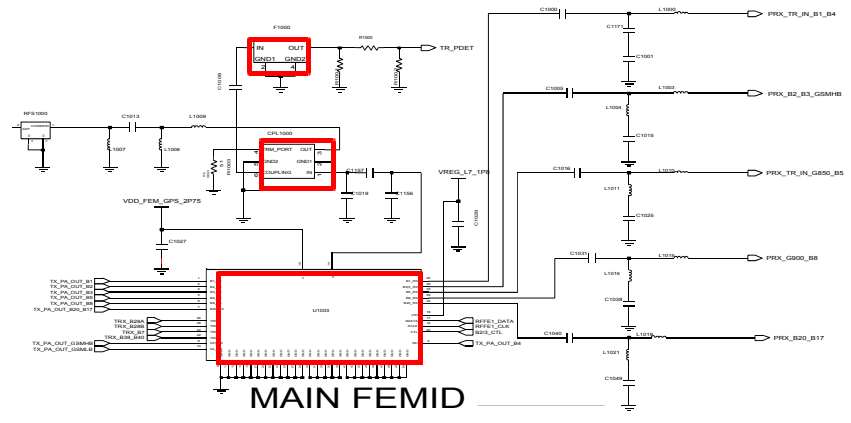

8-3-26. LTE20 RX

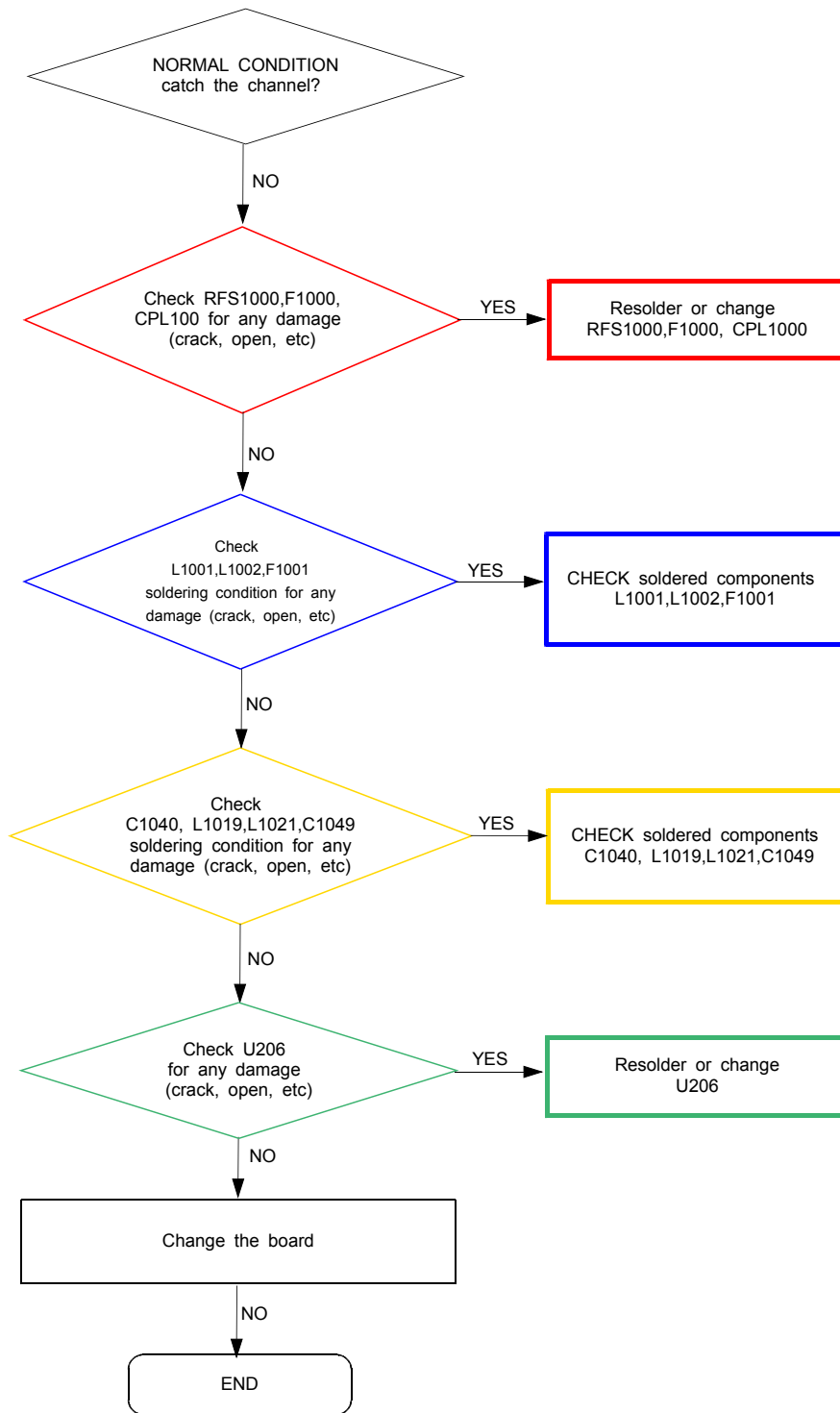

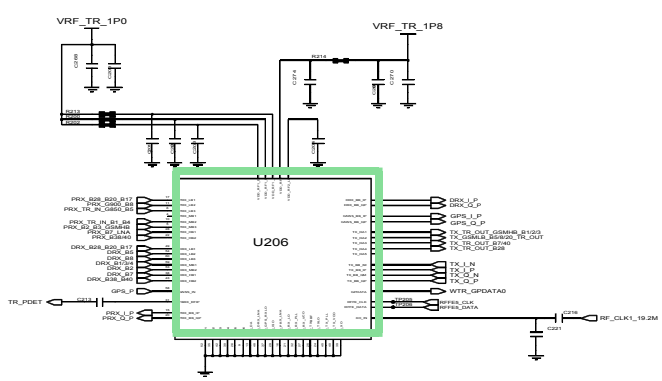
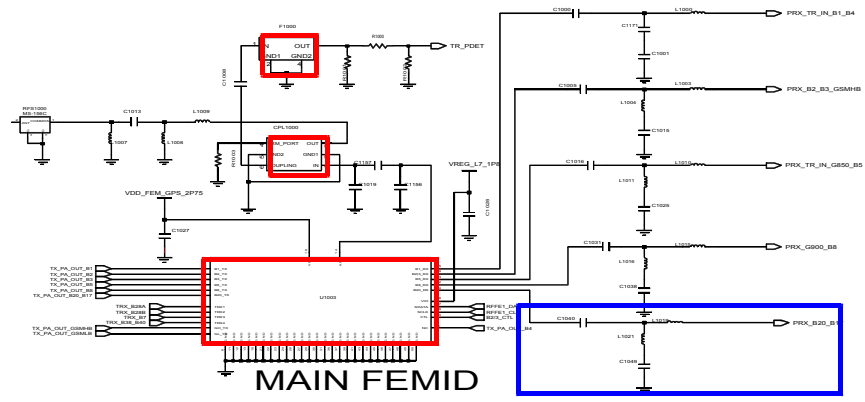

RF Transceiver

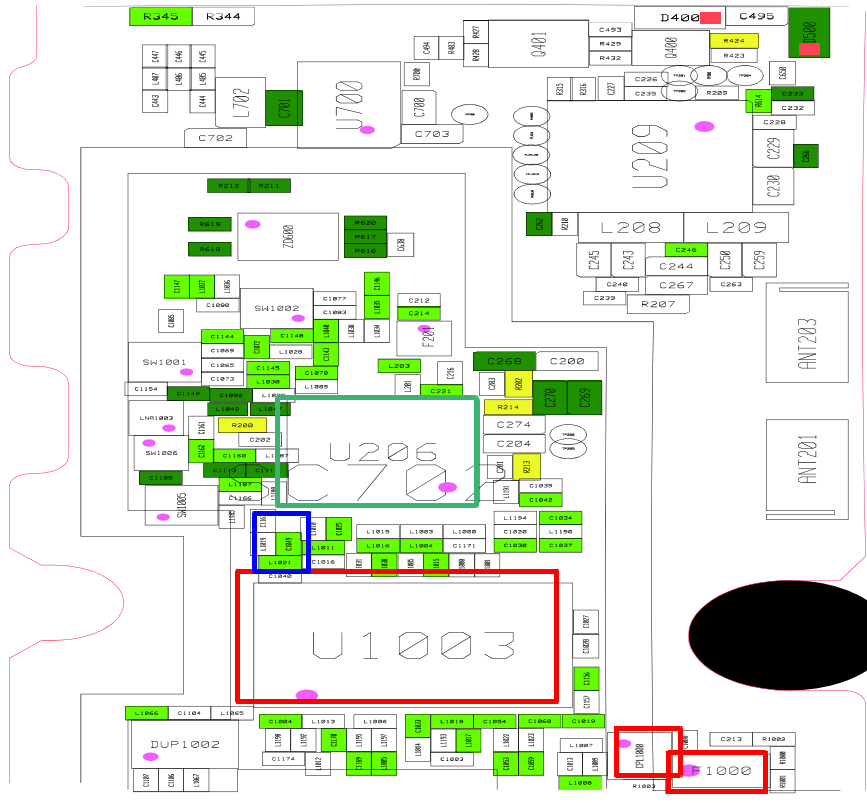

8-3-27. GSM850 / GSM900 TX

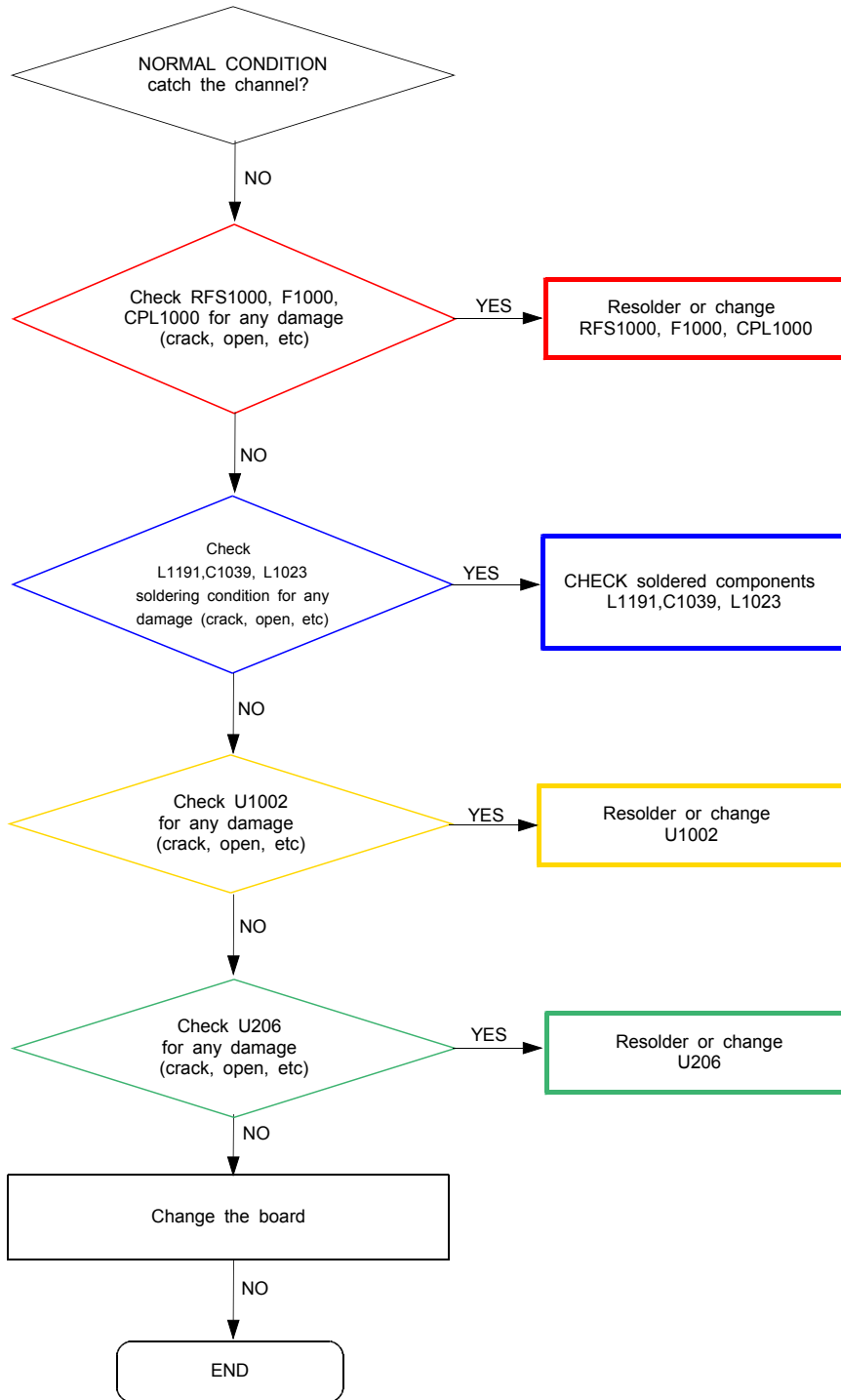

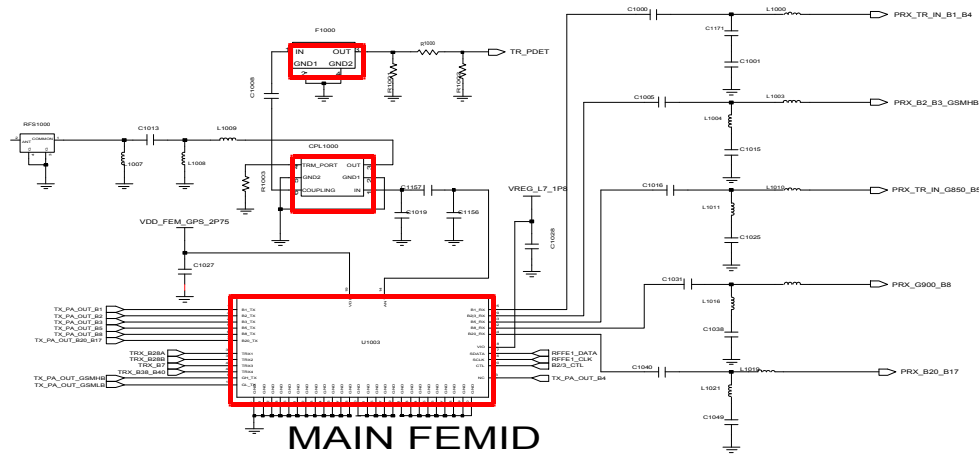

MMMB(GSM_QUAD/WLB1/WB2/WLB3/WLB5/WLB8/LB20)

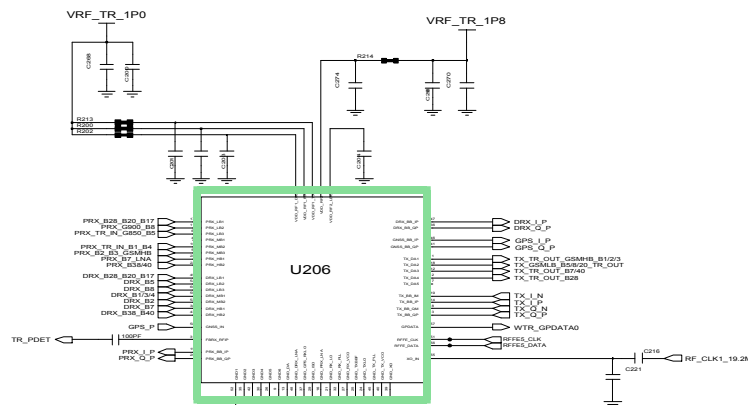
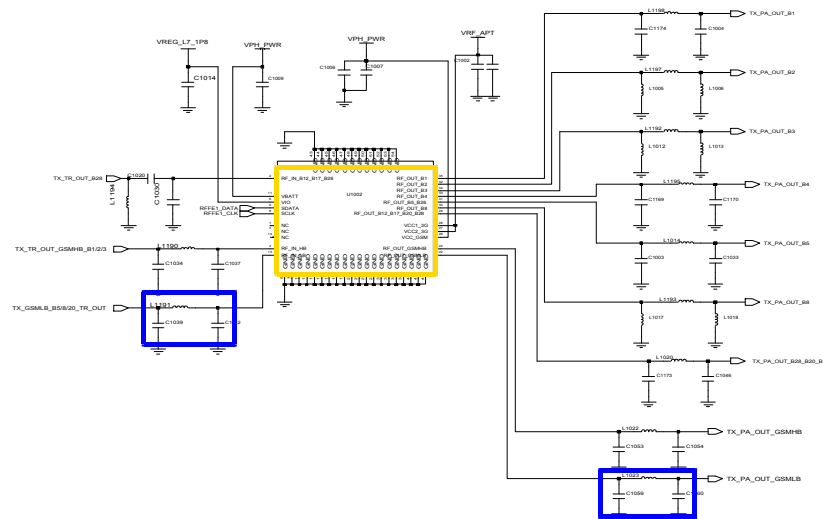

RF Transceiver

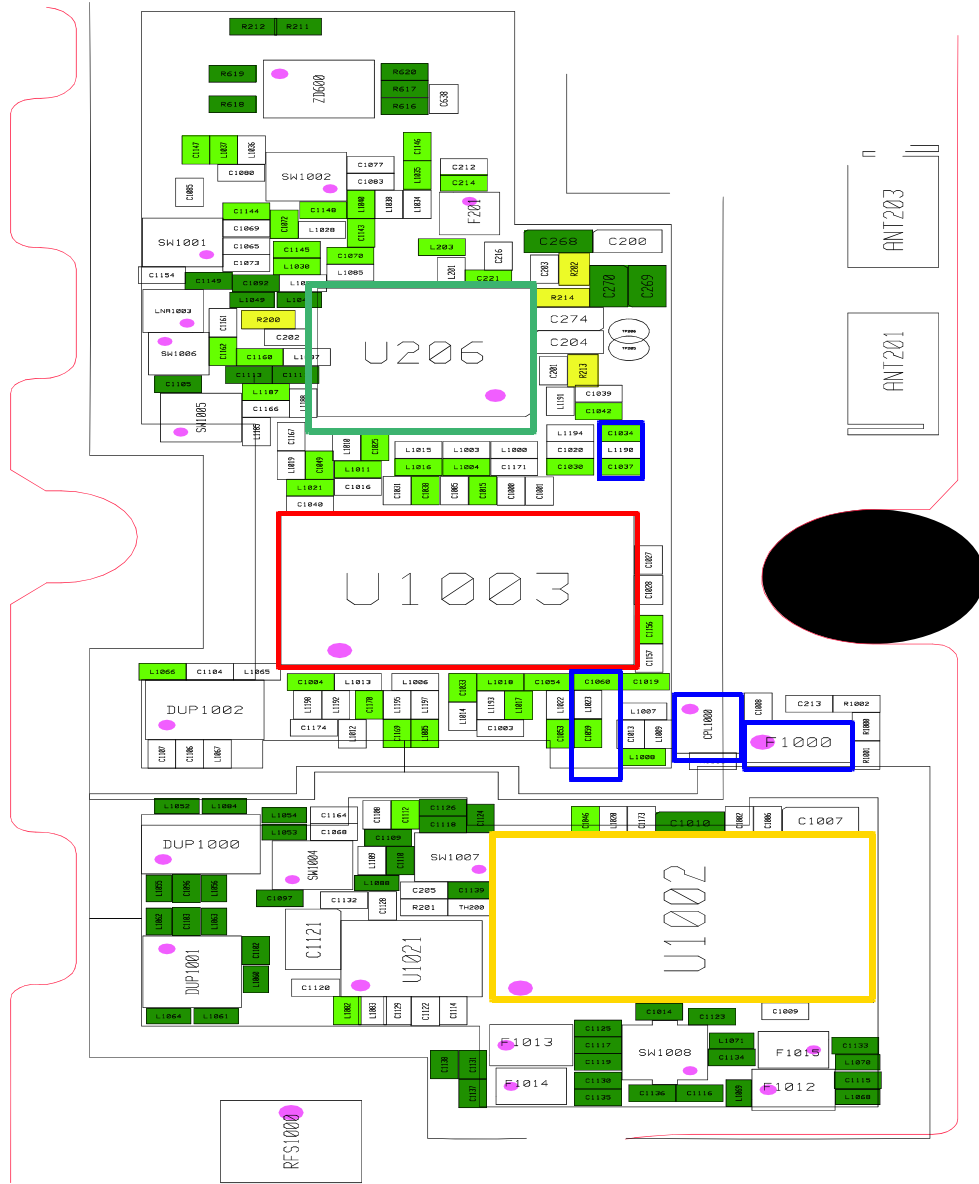

8-3-28. GSM1800 / GSM1900 TX

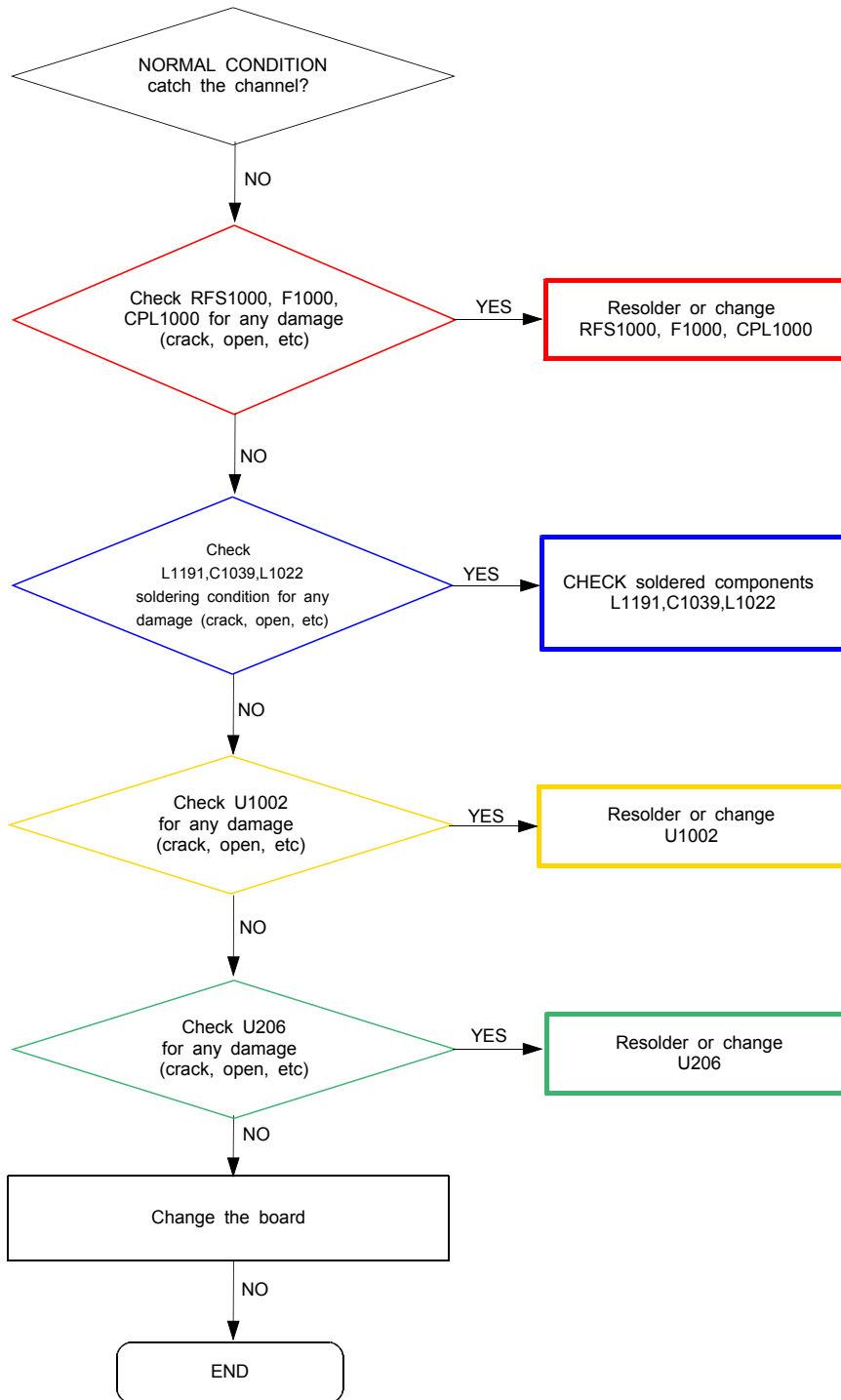

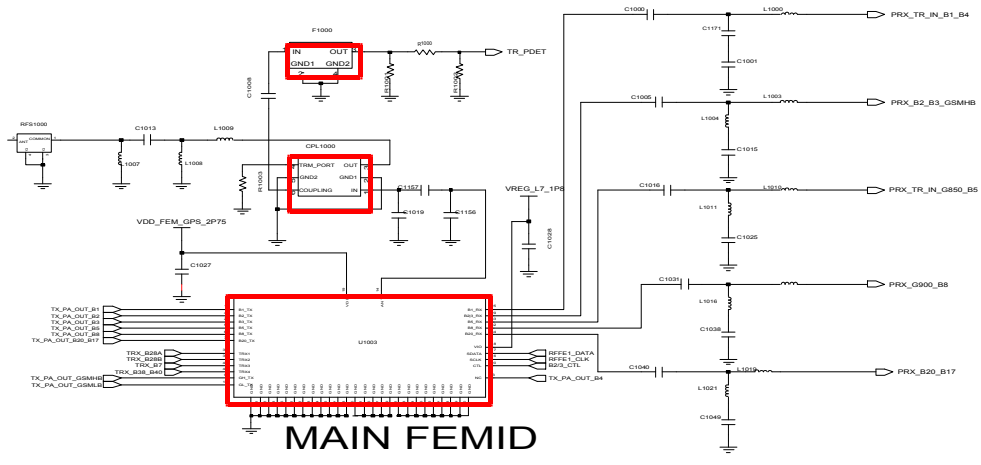

MMMB(GSM_QUAD/WLB1/WB2/WLB3/WLB5/WLB8/LB20)

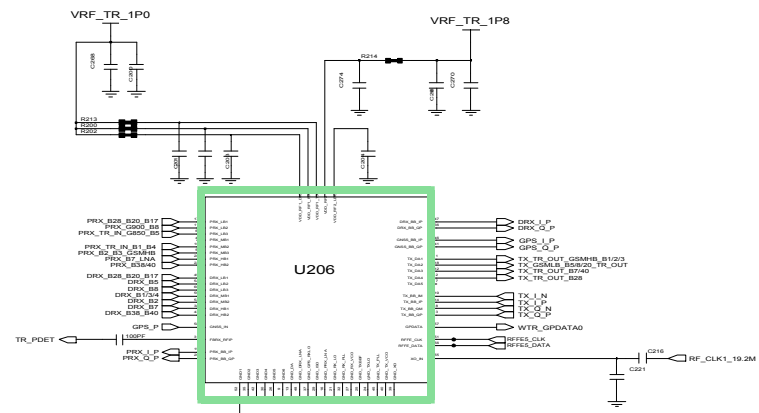
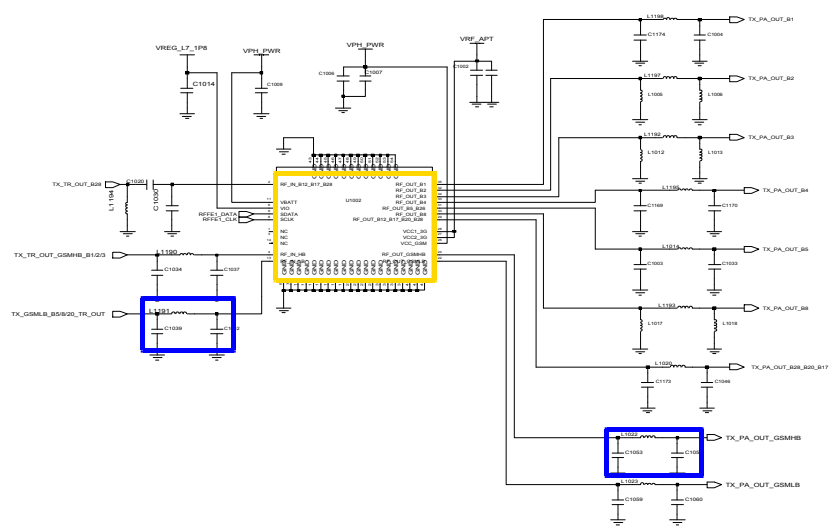

RF Transceiver

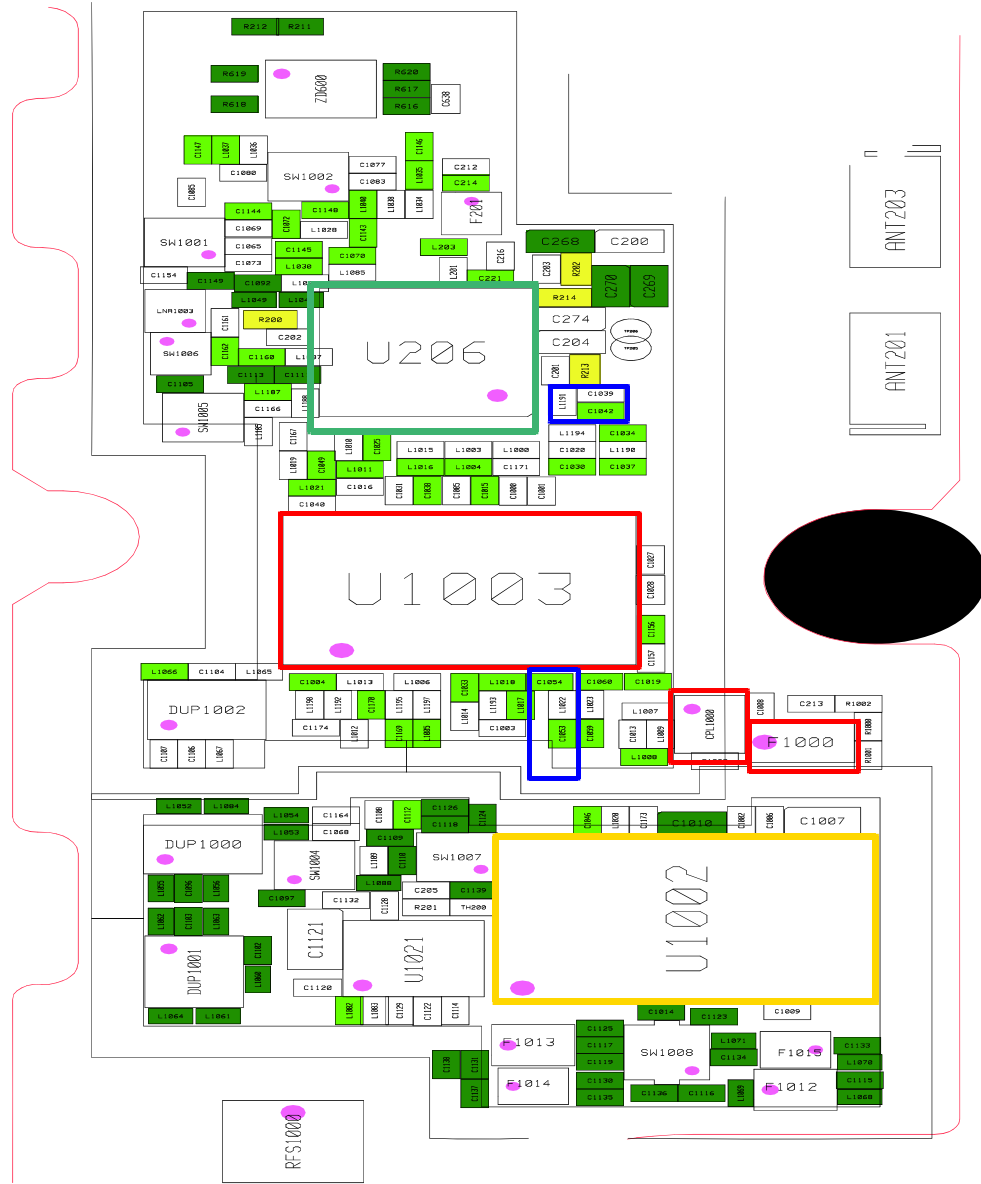

8-3-29. WCDMA B1 / LTE1 TX

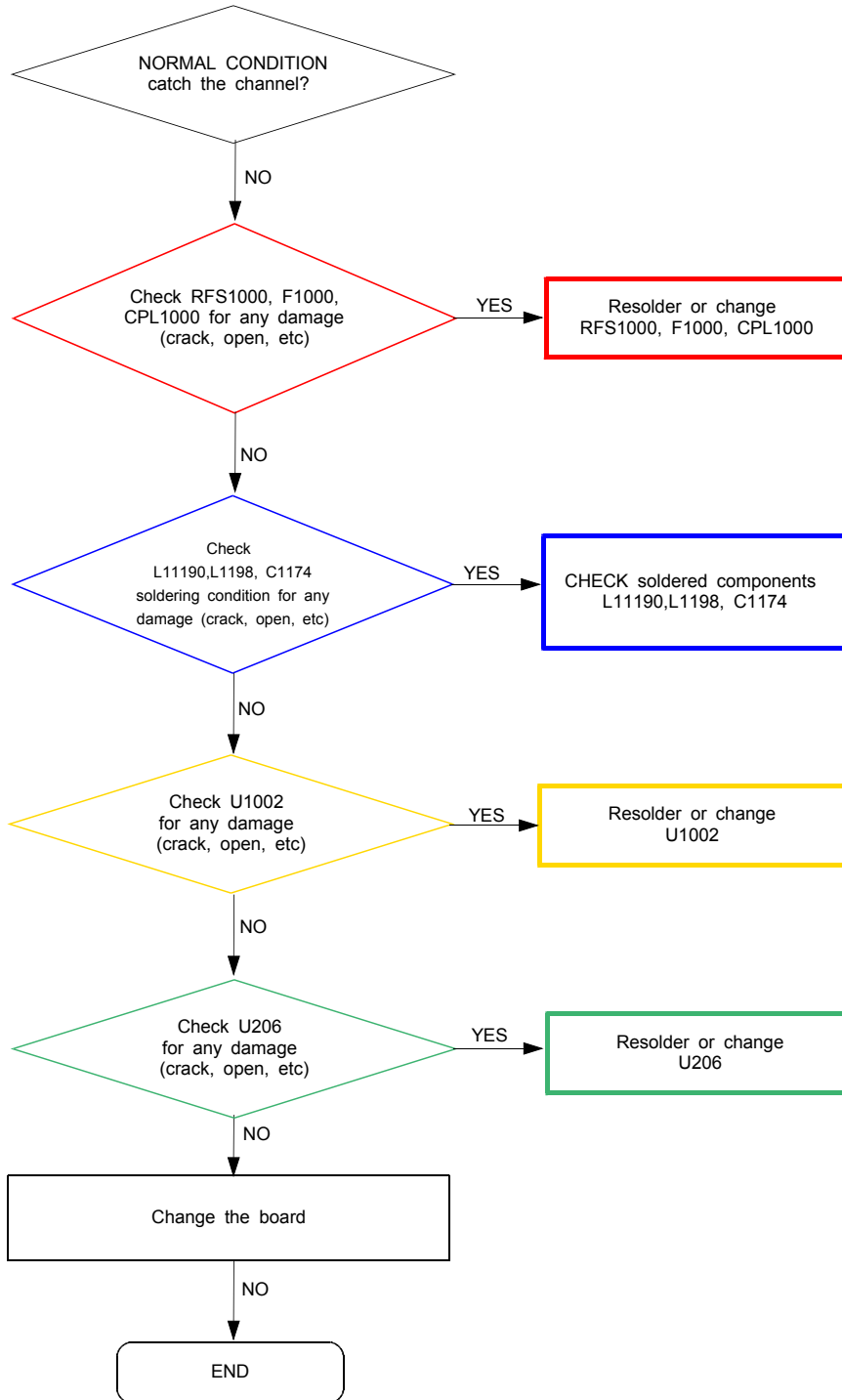

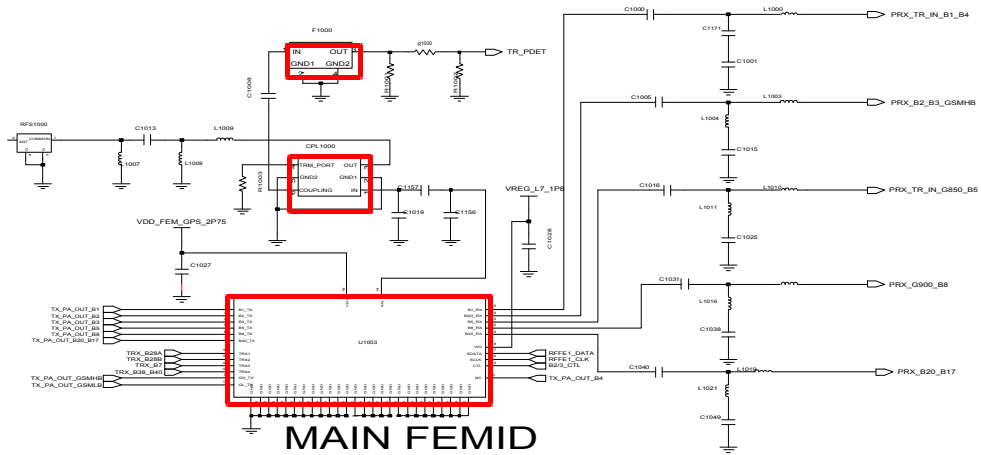

MAIN FEMID

MMMB(GSM_QUAD/WLB1/WB2/WLB3/WLB5/WLB8/LB20)

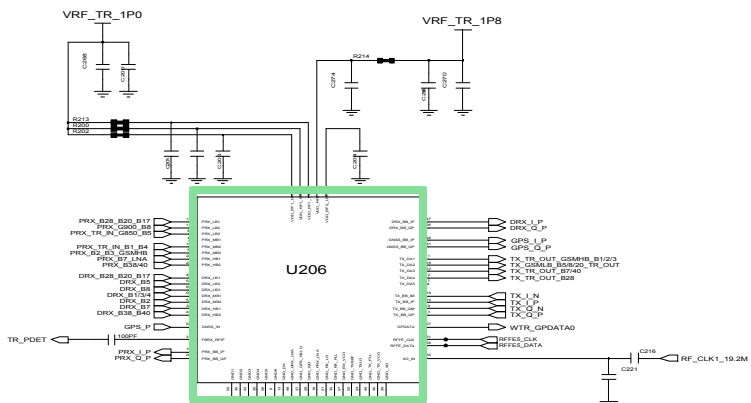
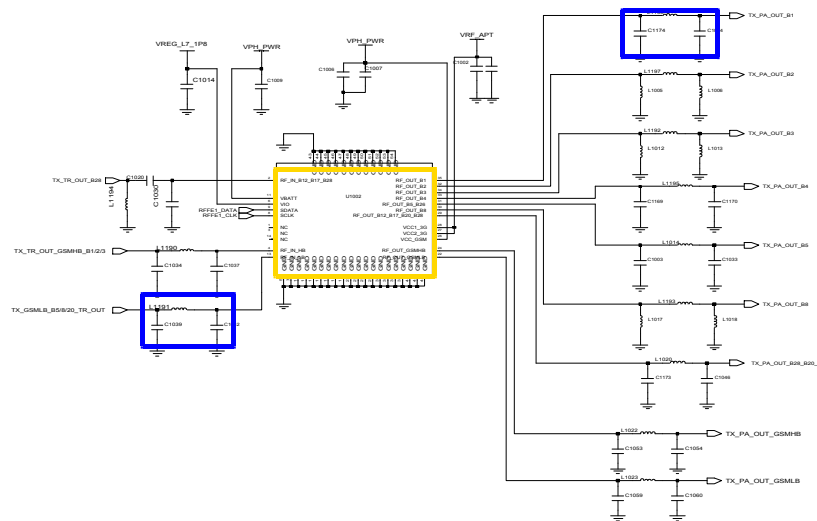

RF Transceiver

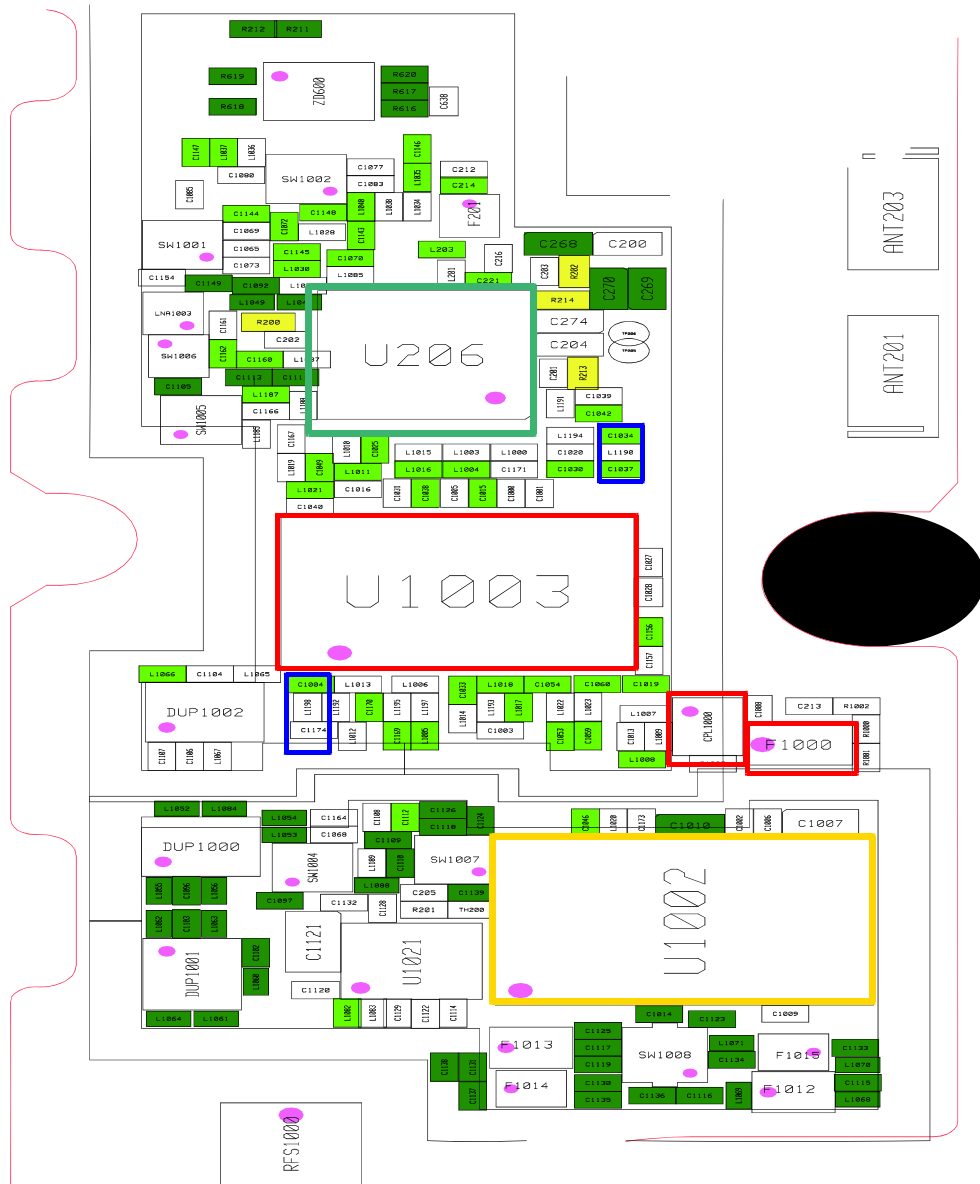

8-3-30. WCDMA B2 TX

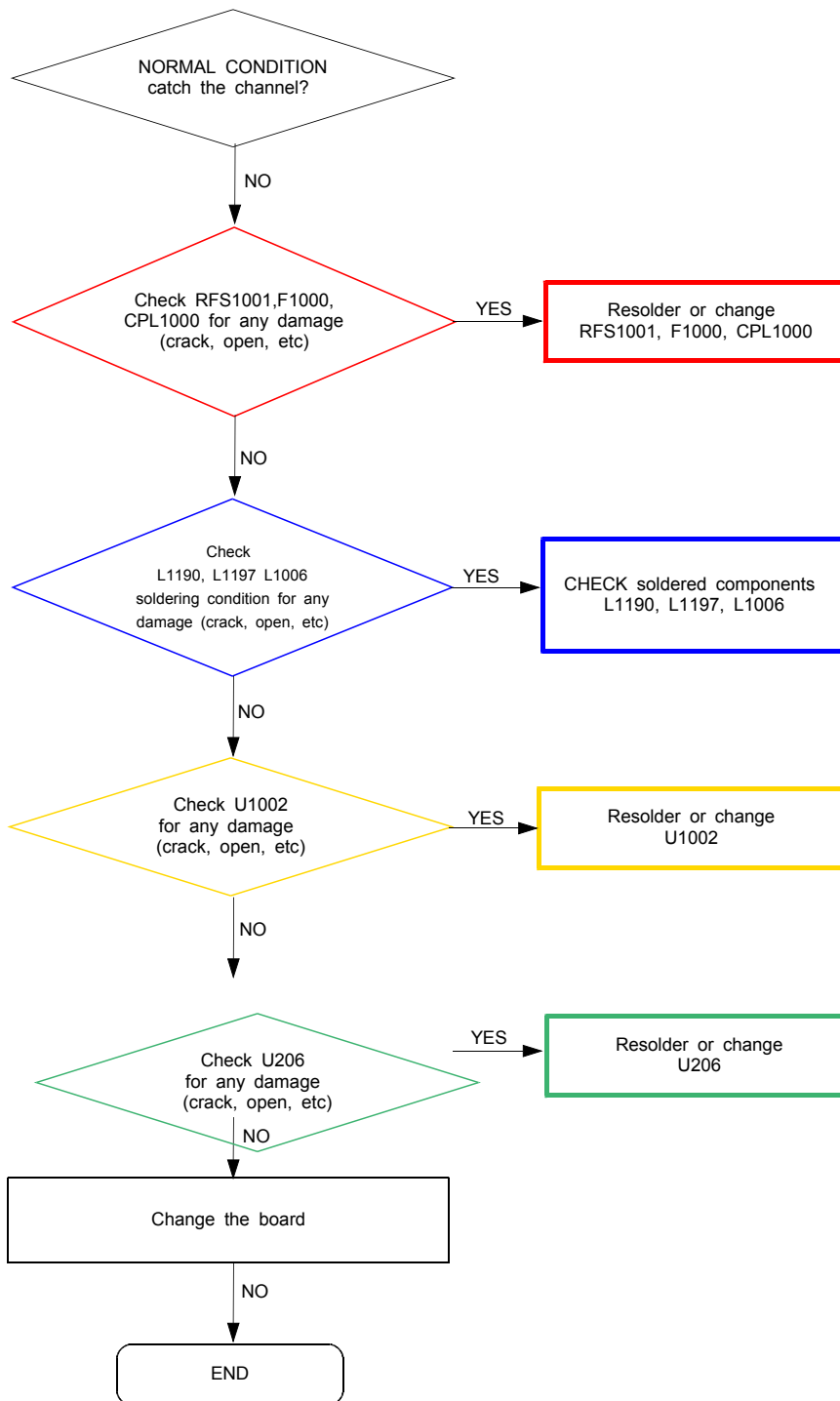

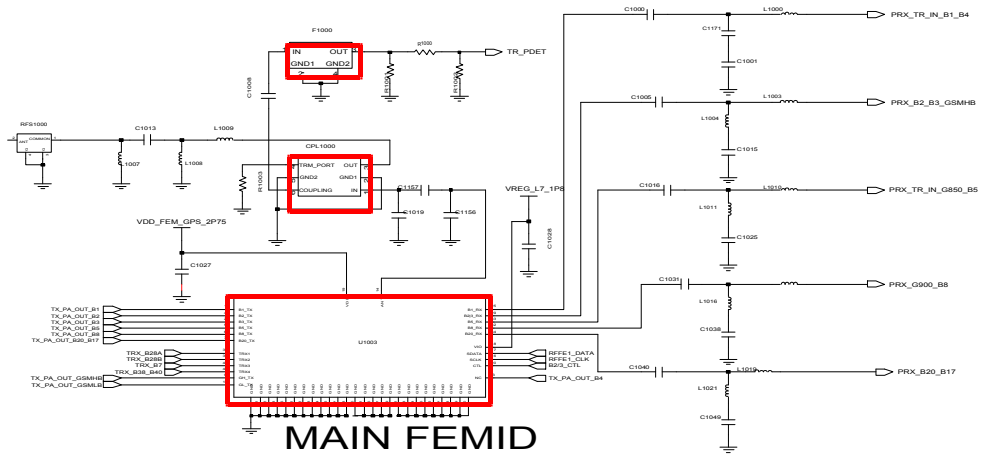

MMMB(GSM_QUAD/WLB1/WB2/WLB3/WLB5/WLB8/LB20)

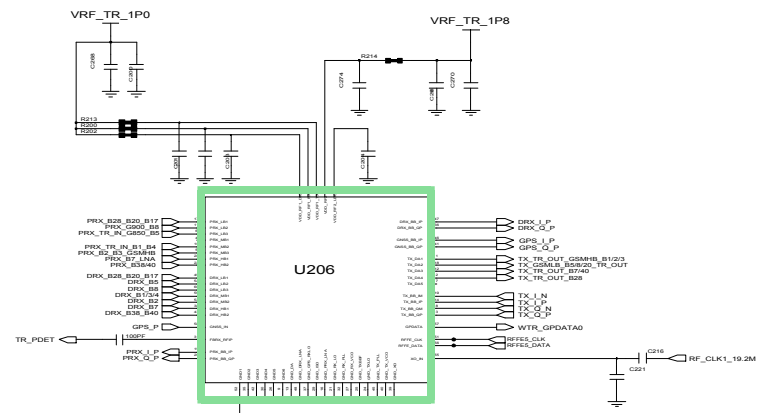
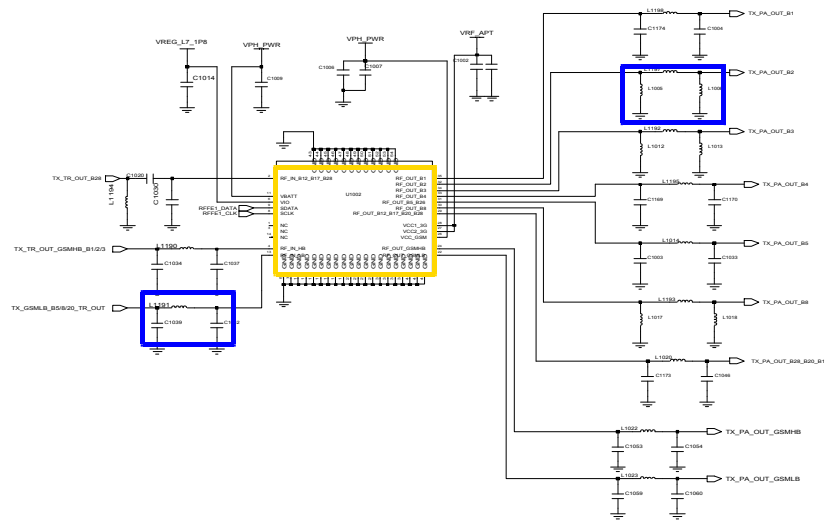

RF Transceiver

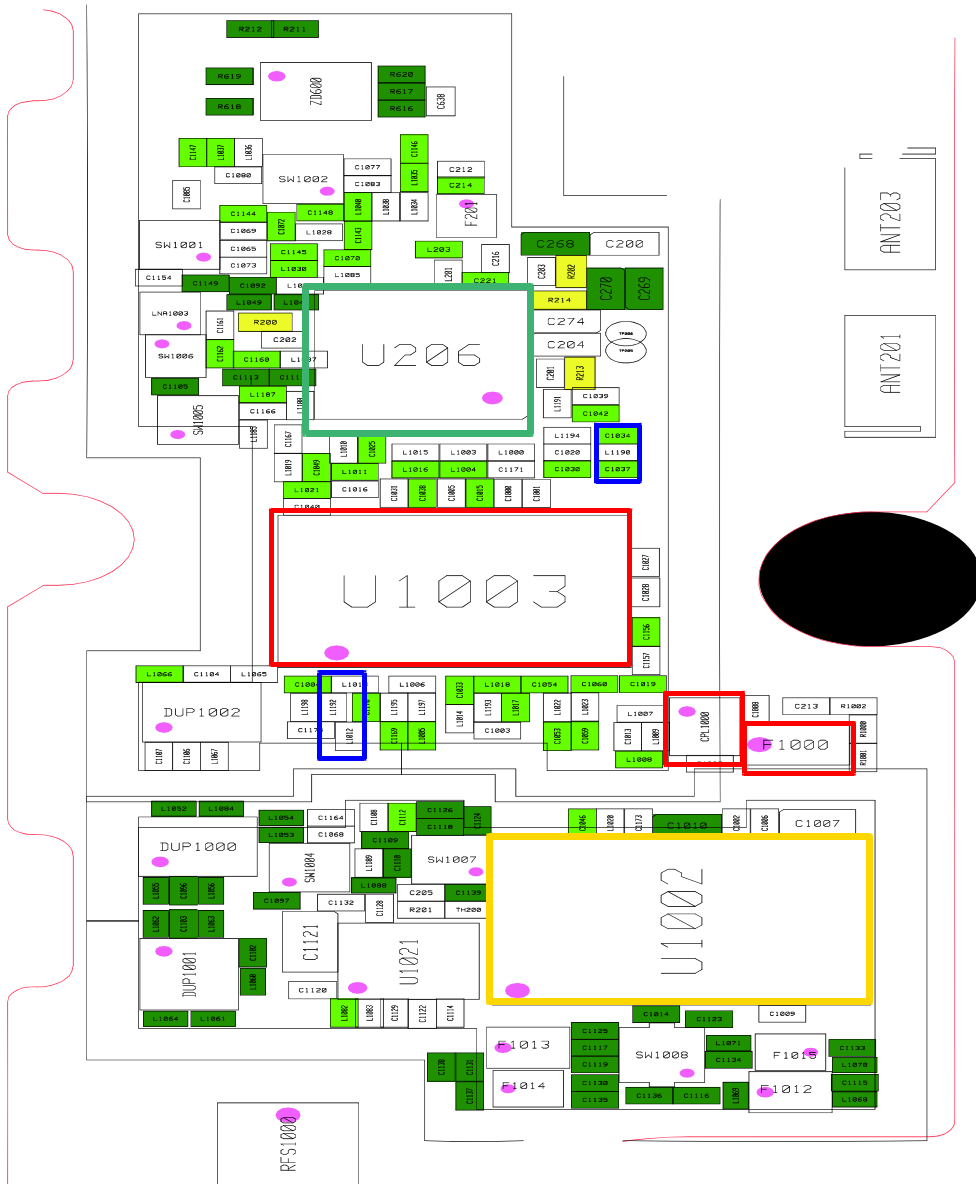

8-3-31. WCDMA B5 / LTE5 TX

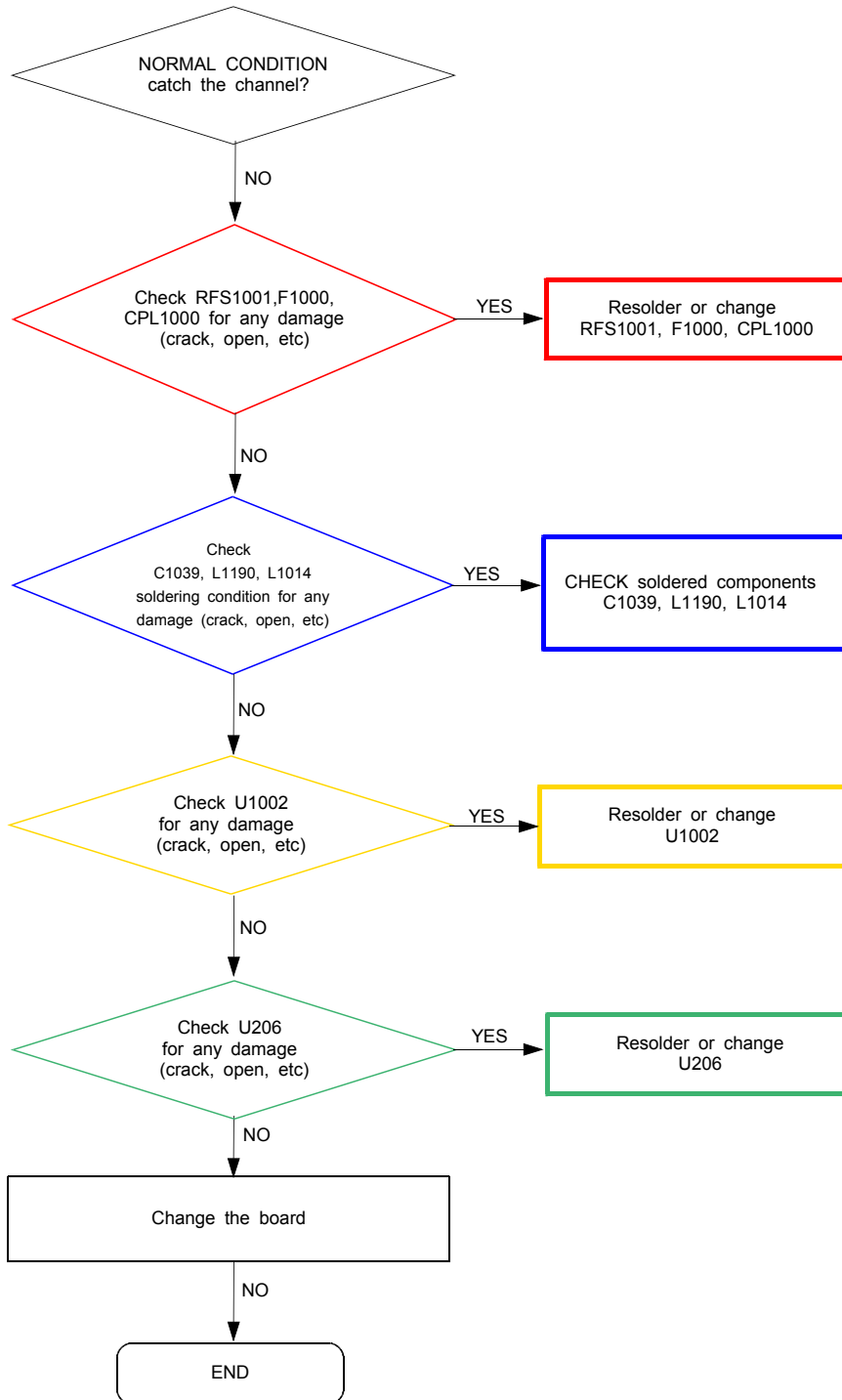

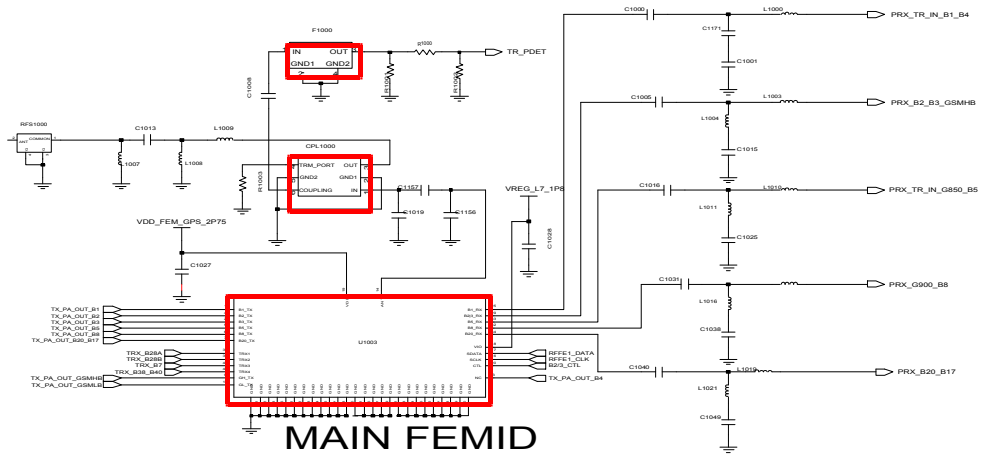

MMMB(GSM_QUAD/WLB1/WB2/WLB3/WLB5/WLB8/LB20)

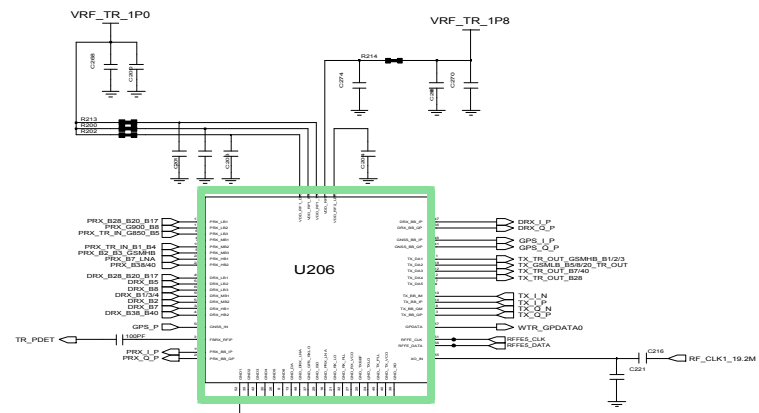
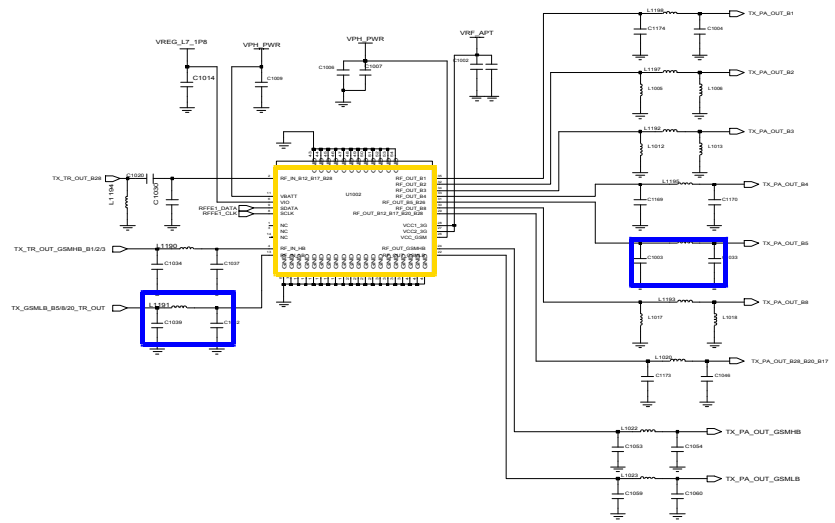

RF Transceiver

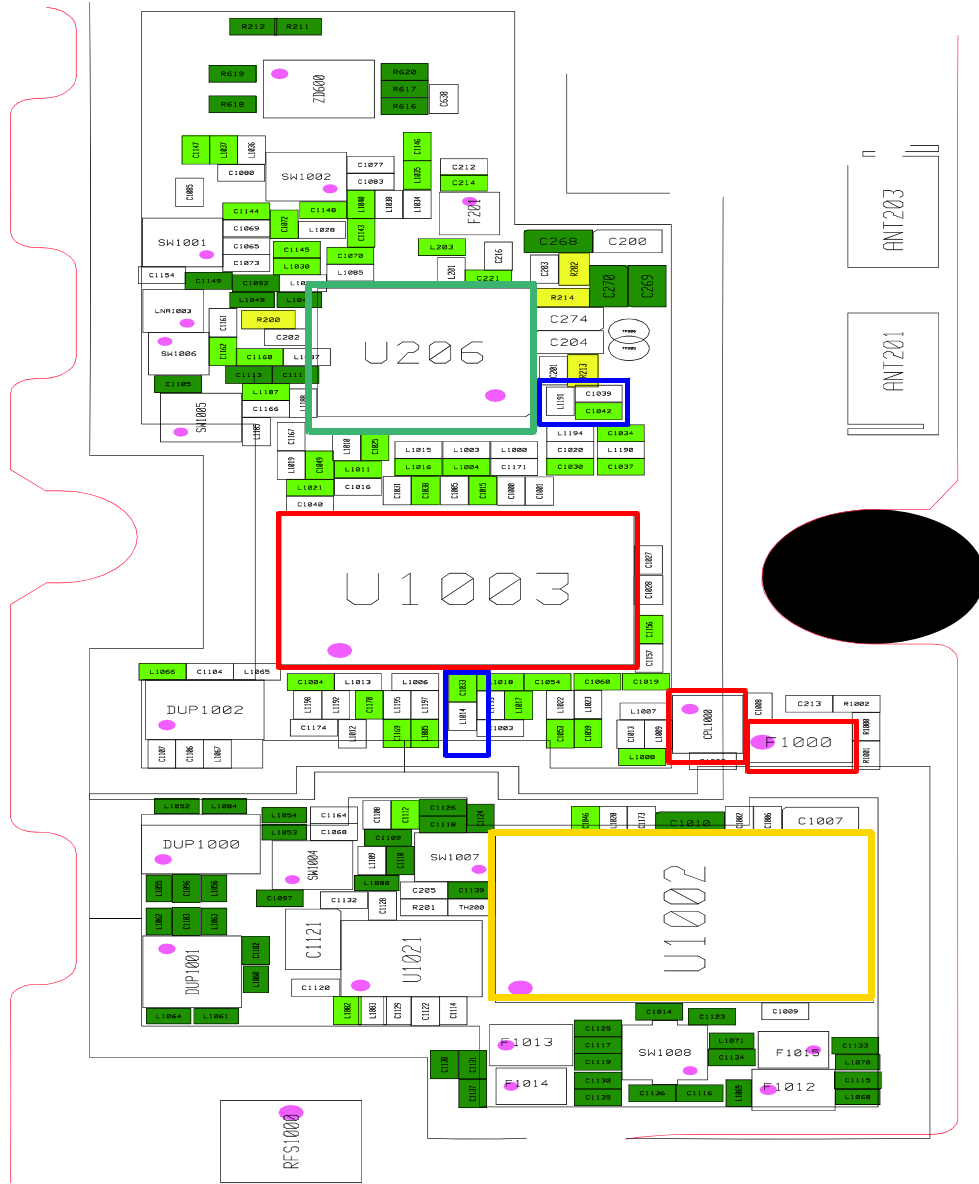

8-3-32. WCDMA B8 / LTE8 TX

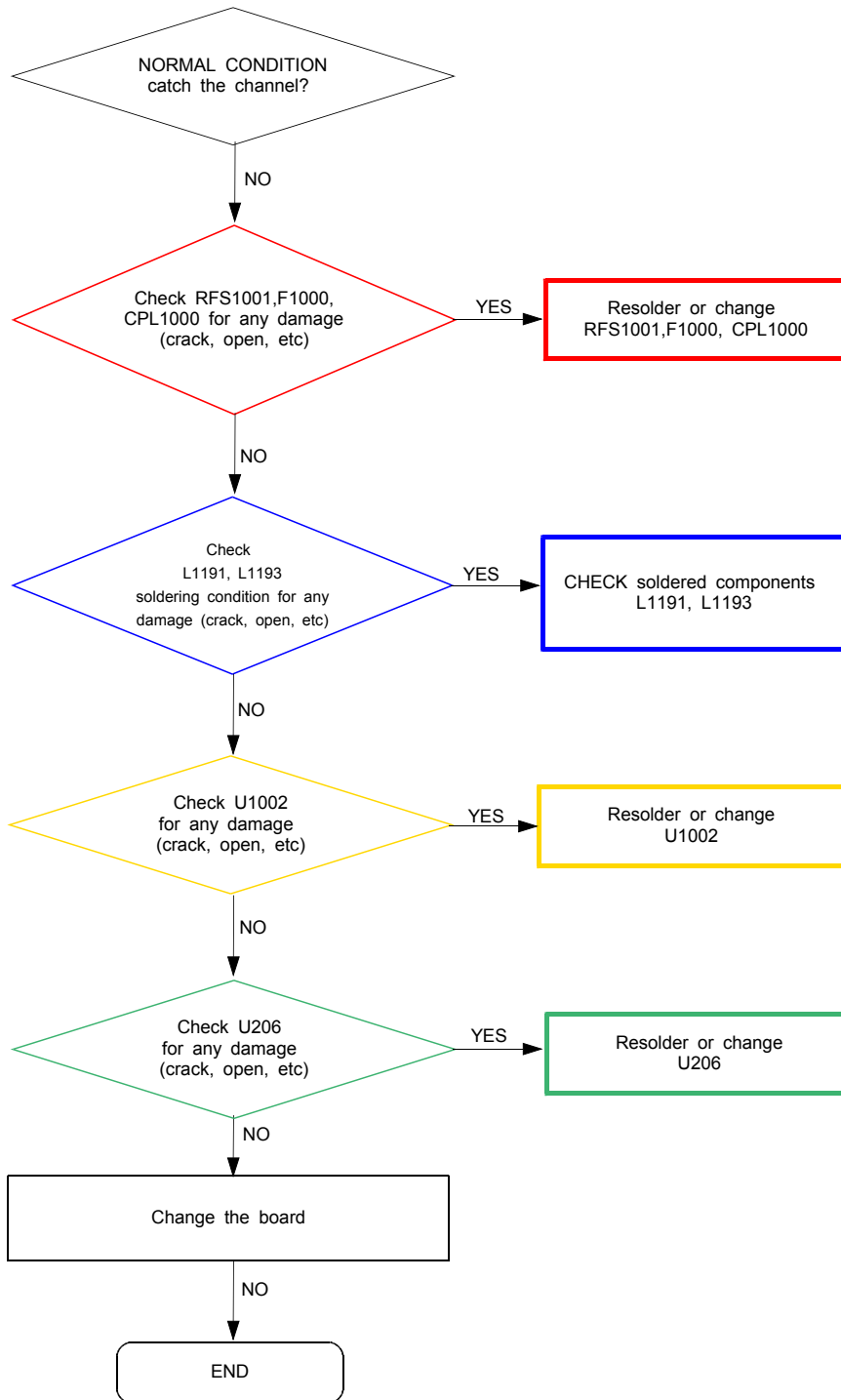

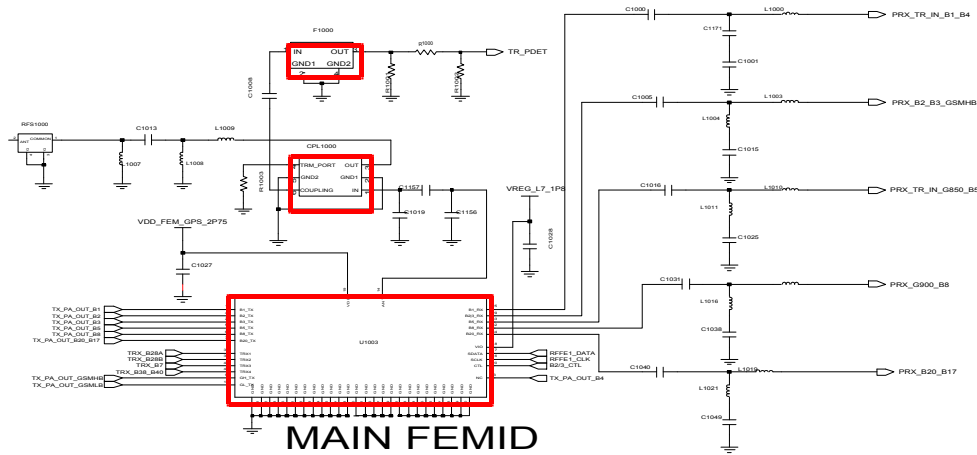

MMMB(GSM_QUAD/WLB1/WB2/WLB3/WLB5/WLB8/LB20)

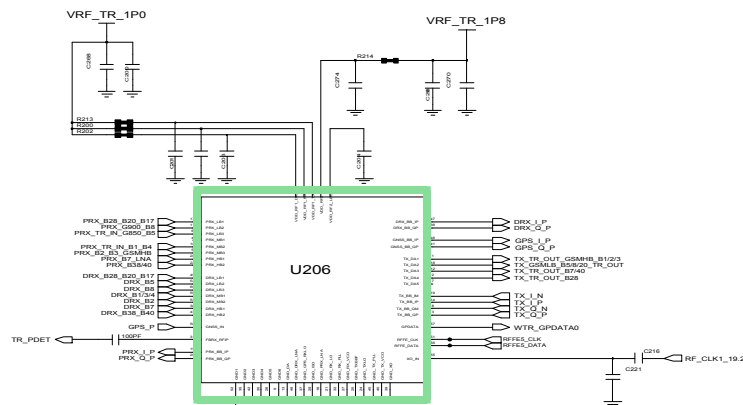
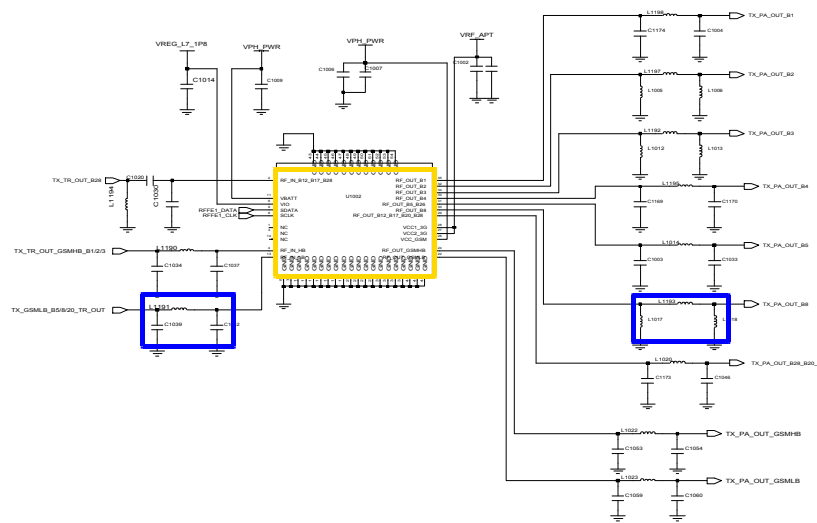

8-3-33. LTE3 TX

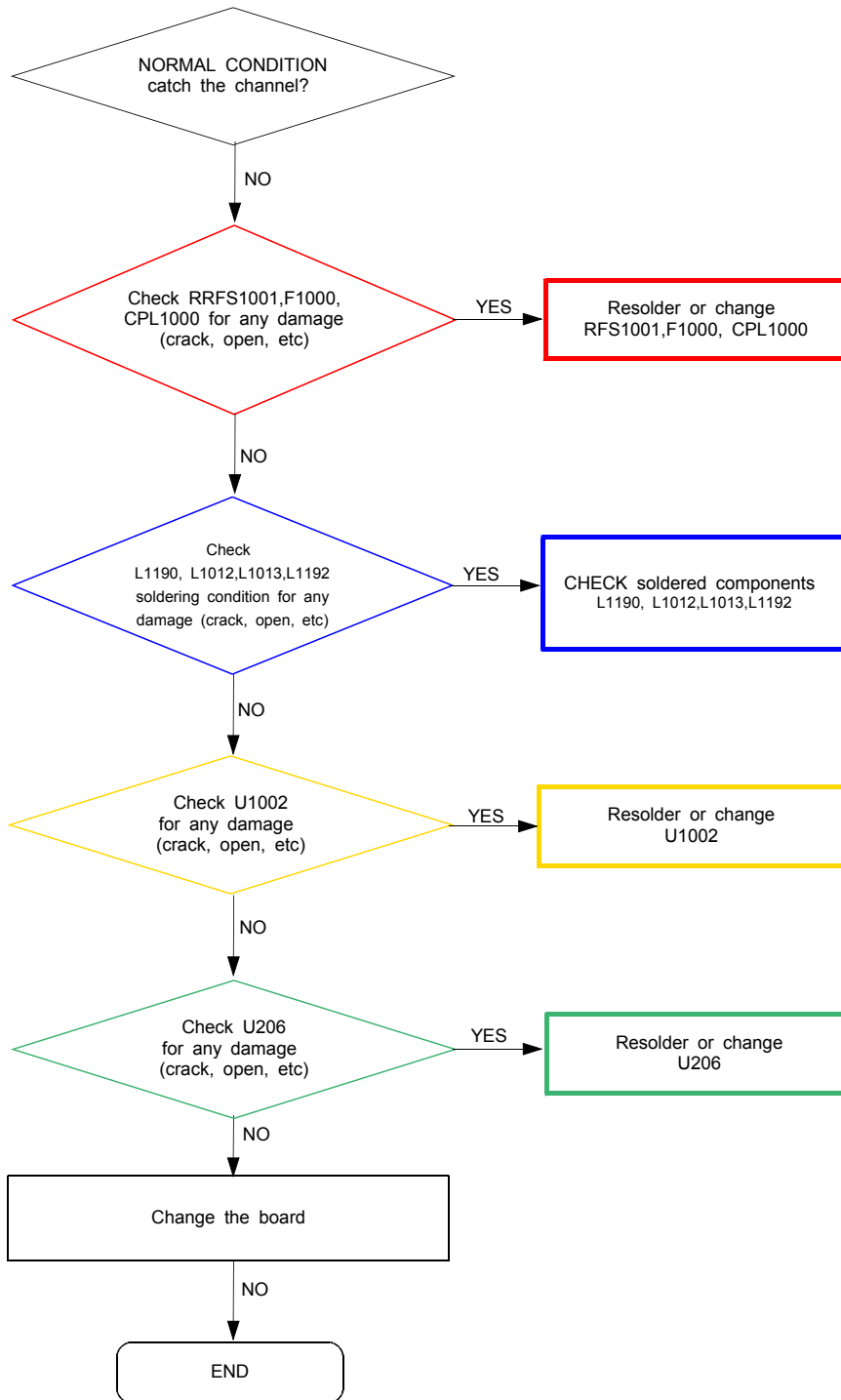

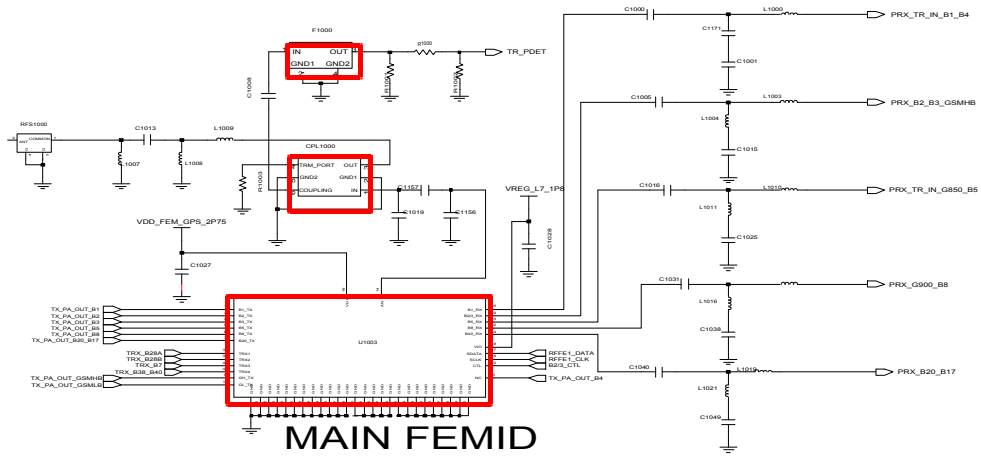

MMMB(GSM_QUAD/WLB1/WB2/WLB3/WLB5/WLB8/LB20)

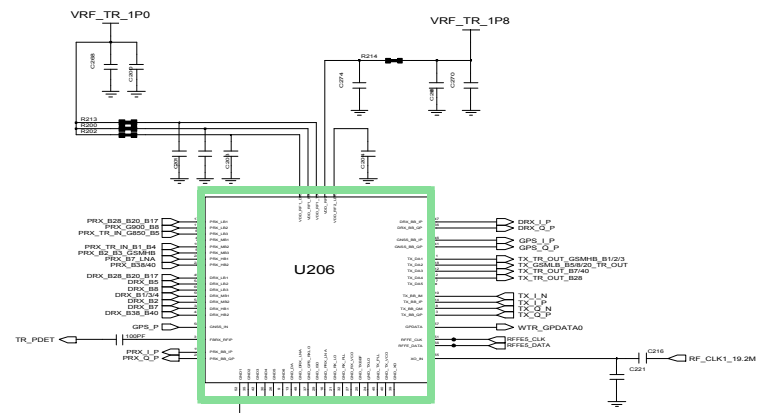
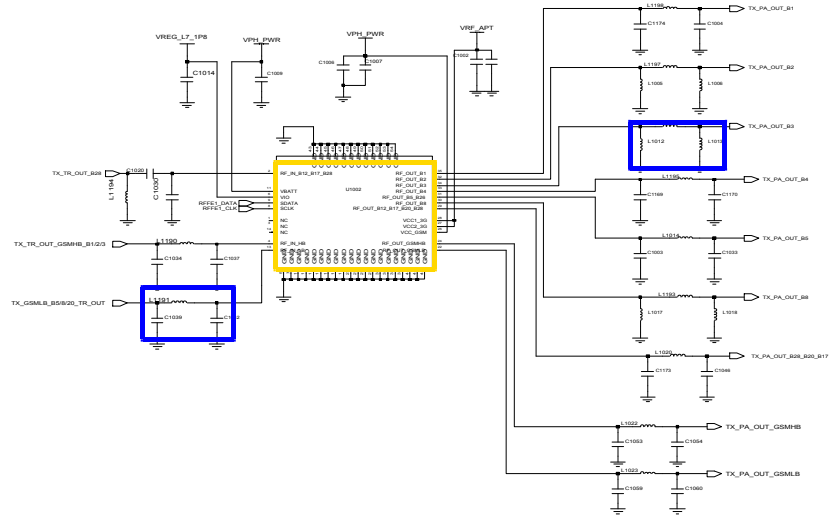

RF Transceiver

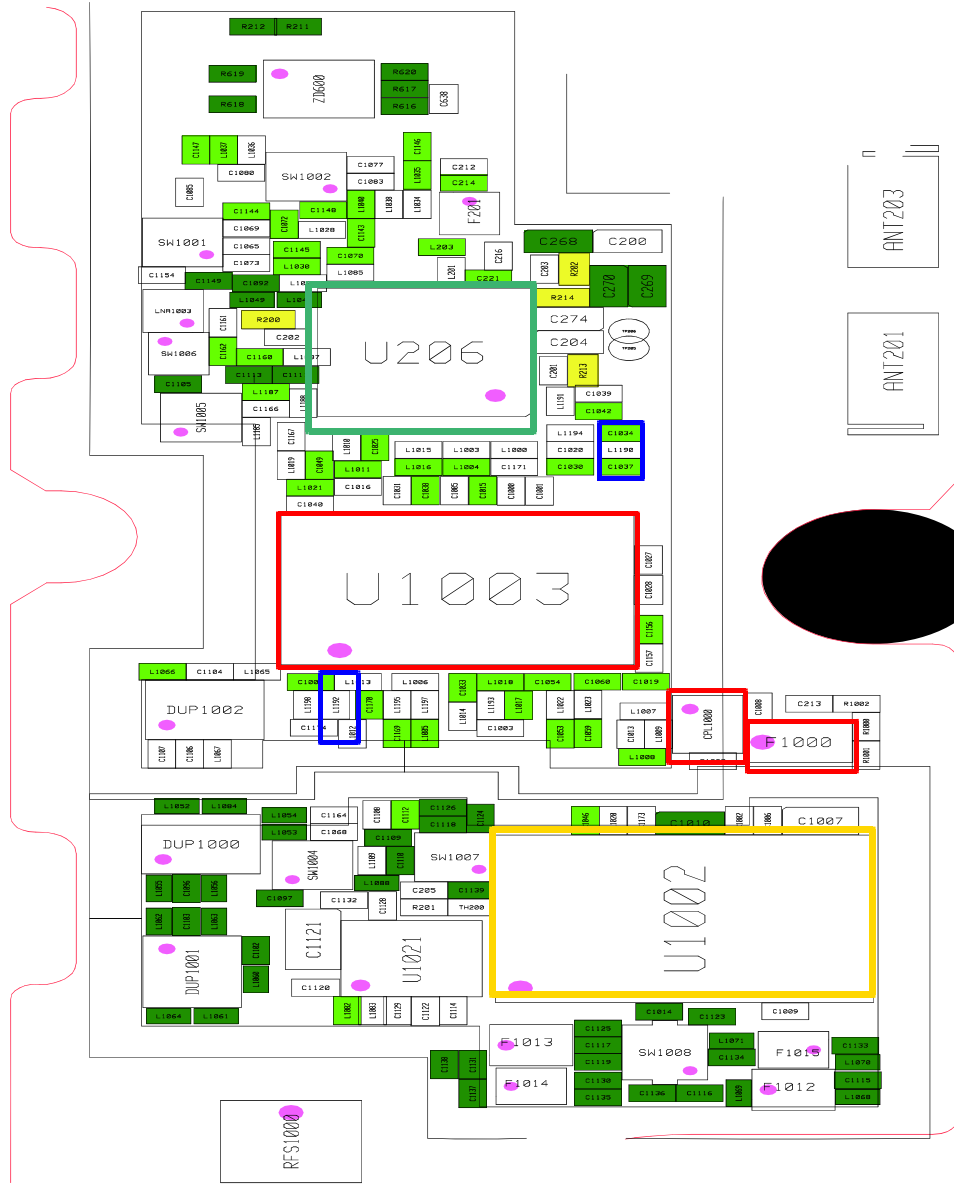

8-3-34. LTE7 TX

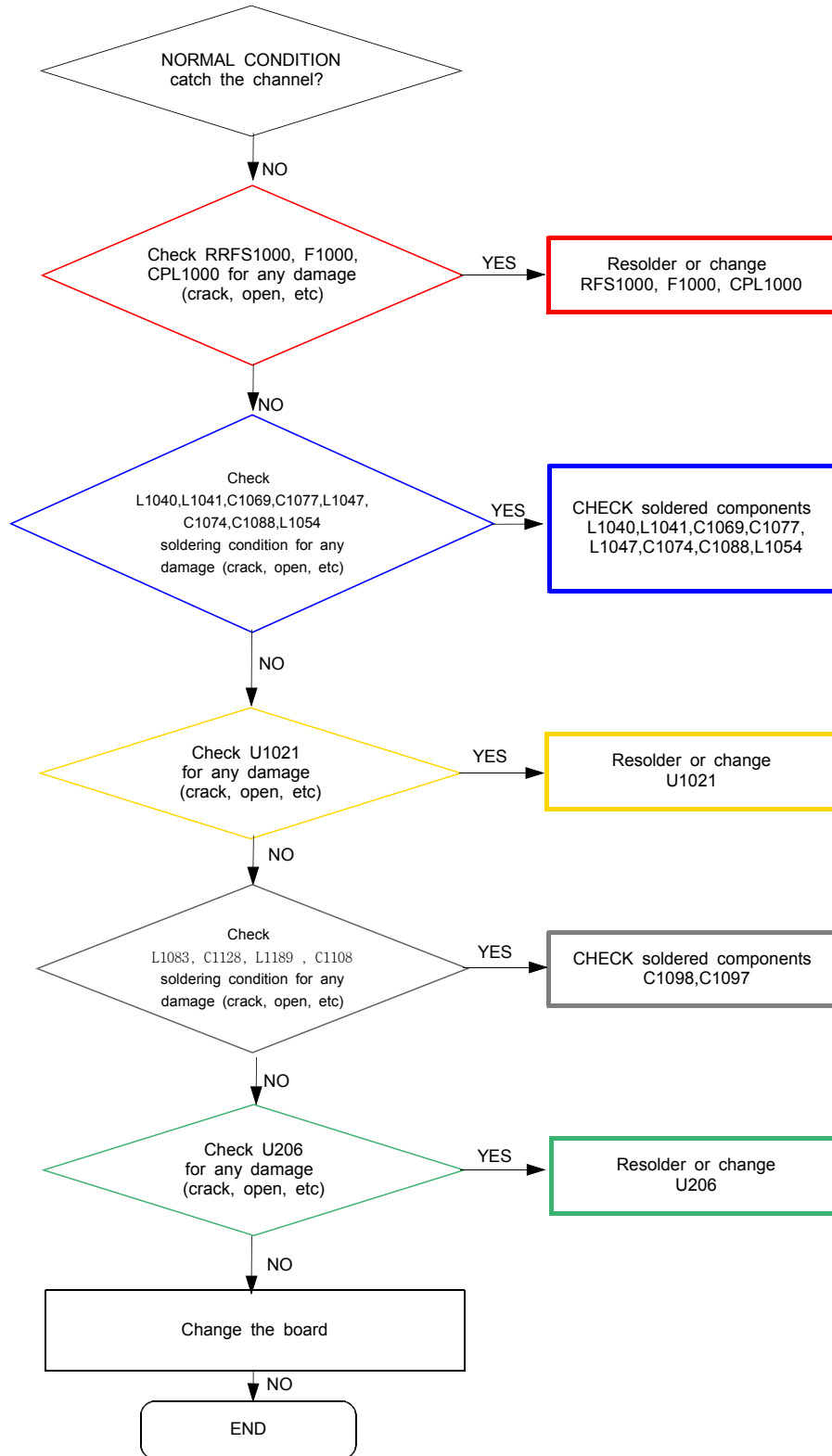

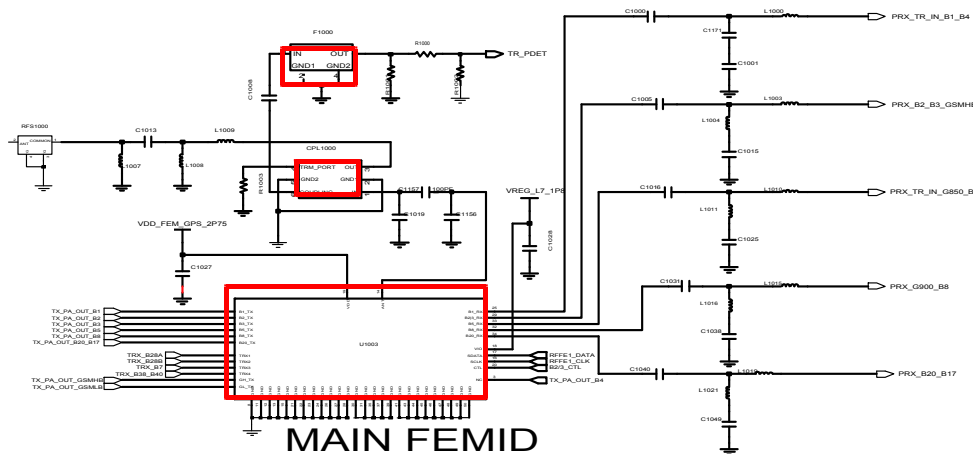

MAIN FEMID

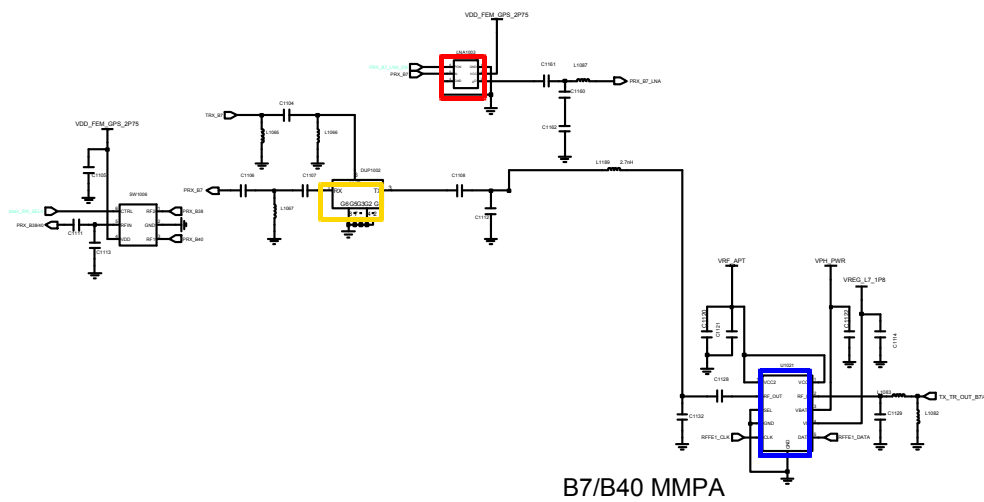

B7/B40 MMPA

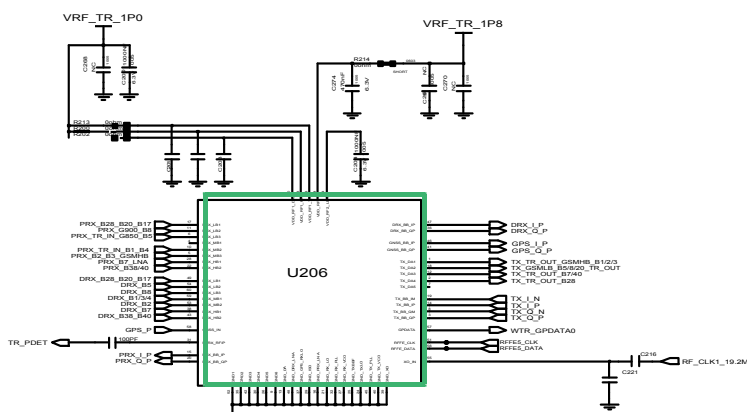

RF Transceiver

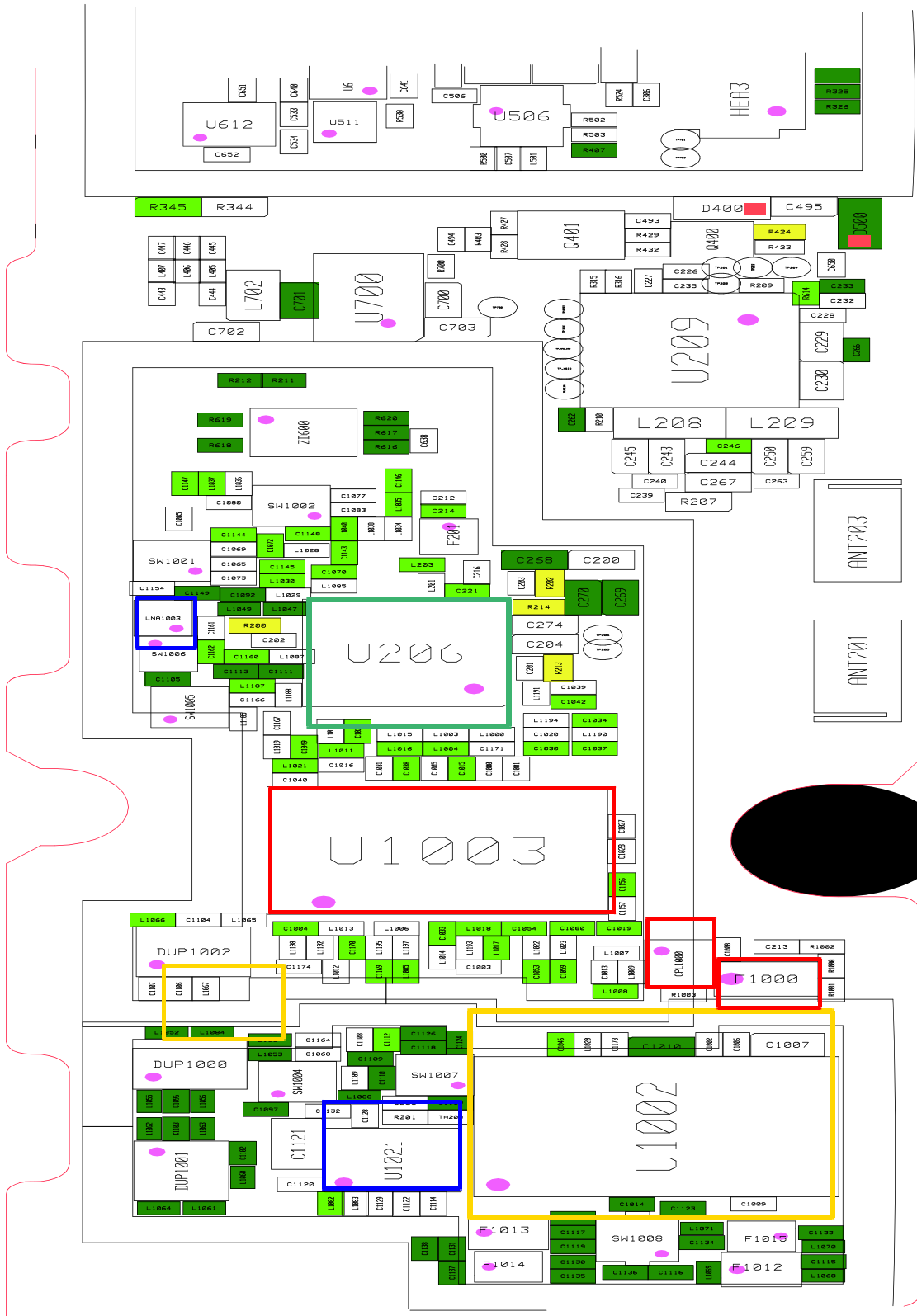

8-3-35. LTE20 TX

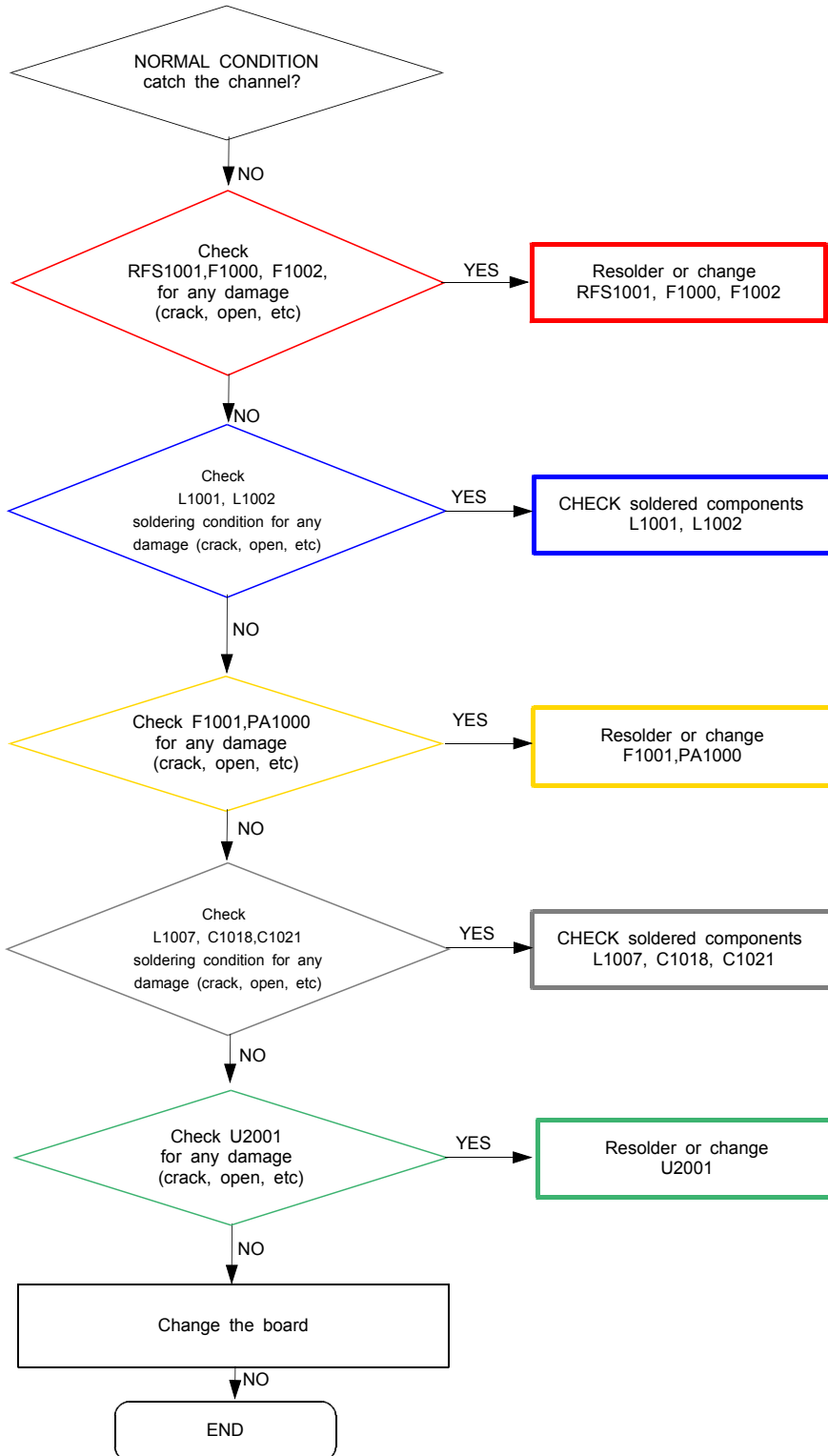

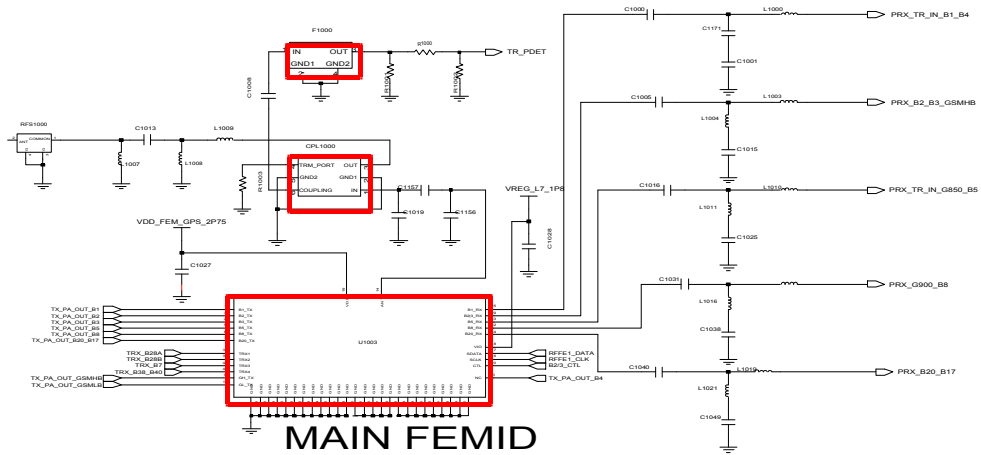

MMMB(GSM_QUAD/WLB1/WB2/WLB3/WLB5/WLB8/LB20)

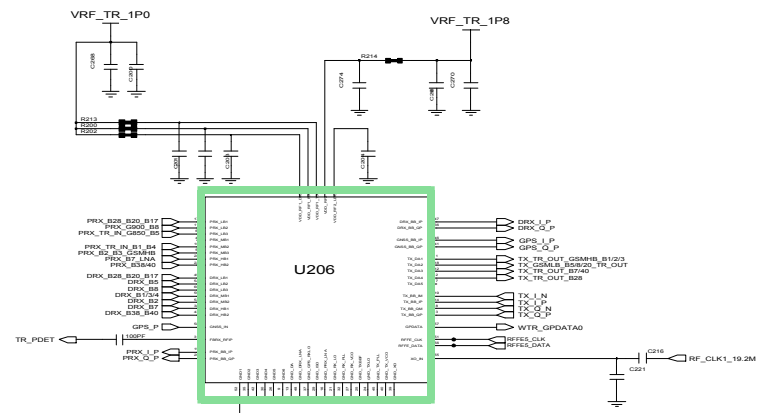
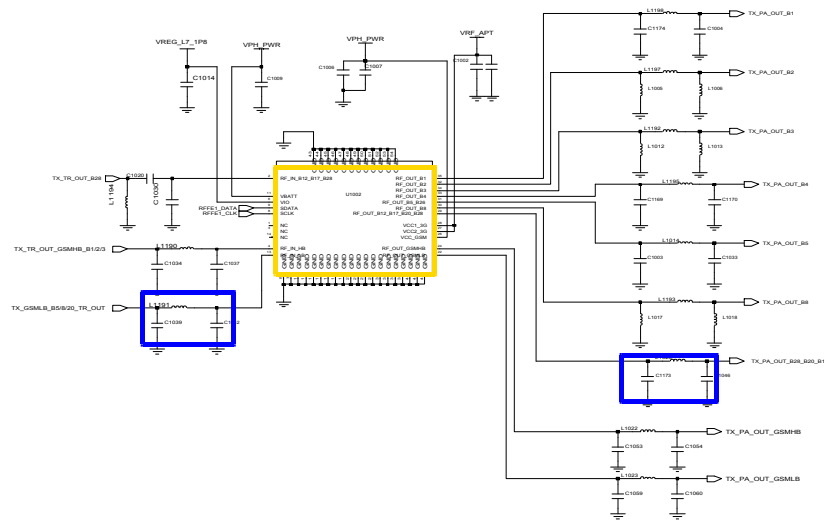

RF Transceiver

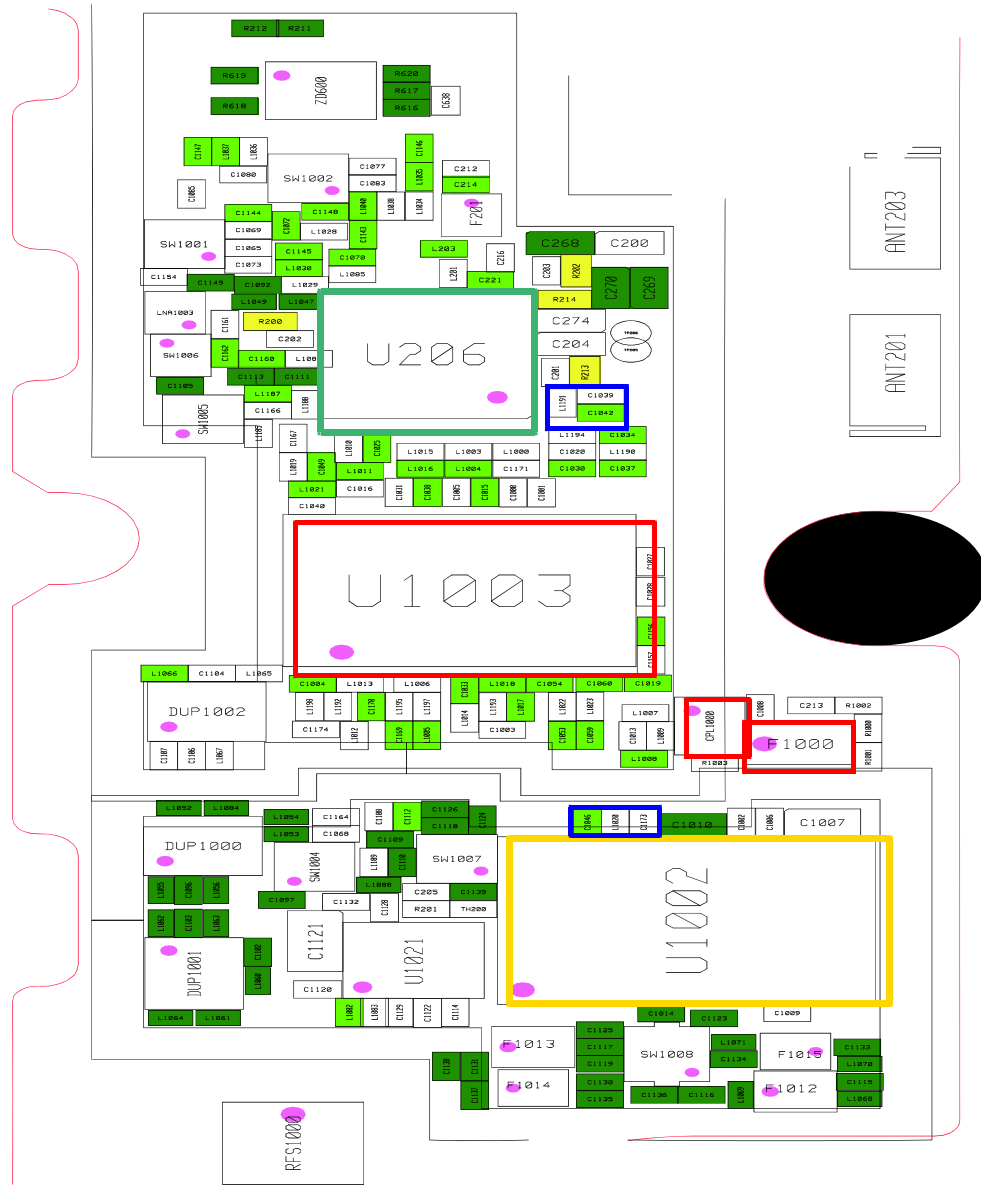

-NC Point(Top View)

●: NC

	1	2	3	4	5	6	7	8	9	10	11	12	13	14
A														
B														
C	●													●
D	●							●	●	●	●	●	●	●
E	●	●	●	●	●	●	●	●	●	●	●	●	●	●
F	●					●	●							●
G	●					●	●							●
H	●					●	●							●
I	●					●	●							●
J	●					●	●							●
K	●					●	●							●
L	●					●	●							●
M	●					●	●							●
N	●					●	●							●
P	●					●	●							●
R	●					●	●							●
T	●					●	●							●
U	●					●	●							●
V	●					●	●							●
W	●					●	●							●
Y	●					●	●							●
AA						●	●							
AB						●	●							

UME400

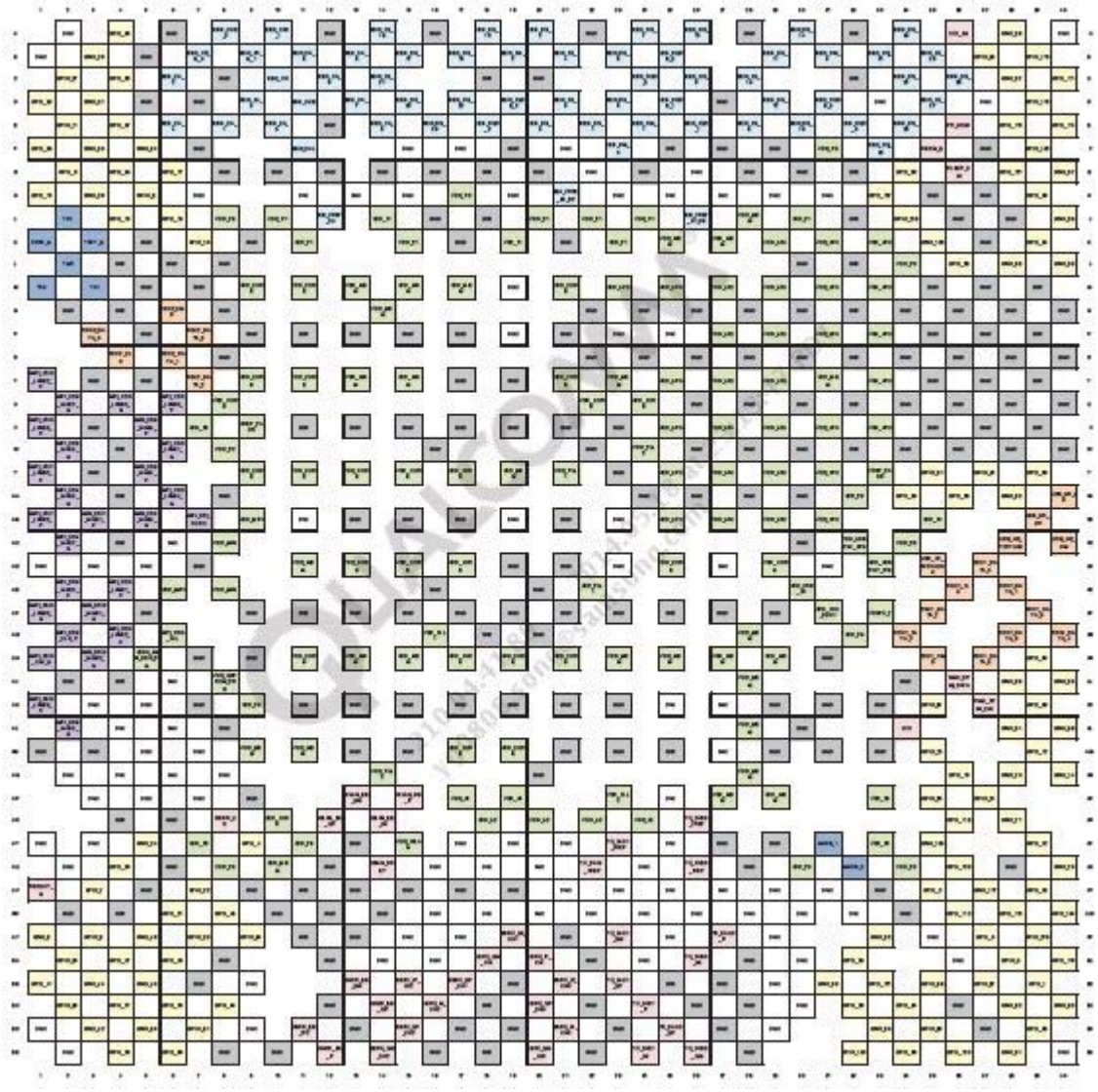

UCP300

	<u>1</u>	<u>2</u>	<u>3</u>	<u>4</u>	<u>5</u>	<u>6</u>	<u>7</u>	<u>8</u>	<u>9</u>	<u>10</u>	<u>11</u>	<u>12</u>	<u>13</u>	<u>14</u>
<u>A</u>														
<u>B</u>														
<u>C</u>									●					
<u>D</u>							●	●						
<u>E</u>					●									
<u>F</u>			●		●									
<u>G</u>														
<u>H</u>	●		●					●						●
<u>J</u>								●						
<u>K</u>					●	●					●			
<u>L</u>				●	●	●		●						
<u>M</u>														●
<u>N</u>														
<u>P</u>										●				

U400

8-1. Block Diagram

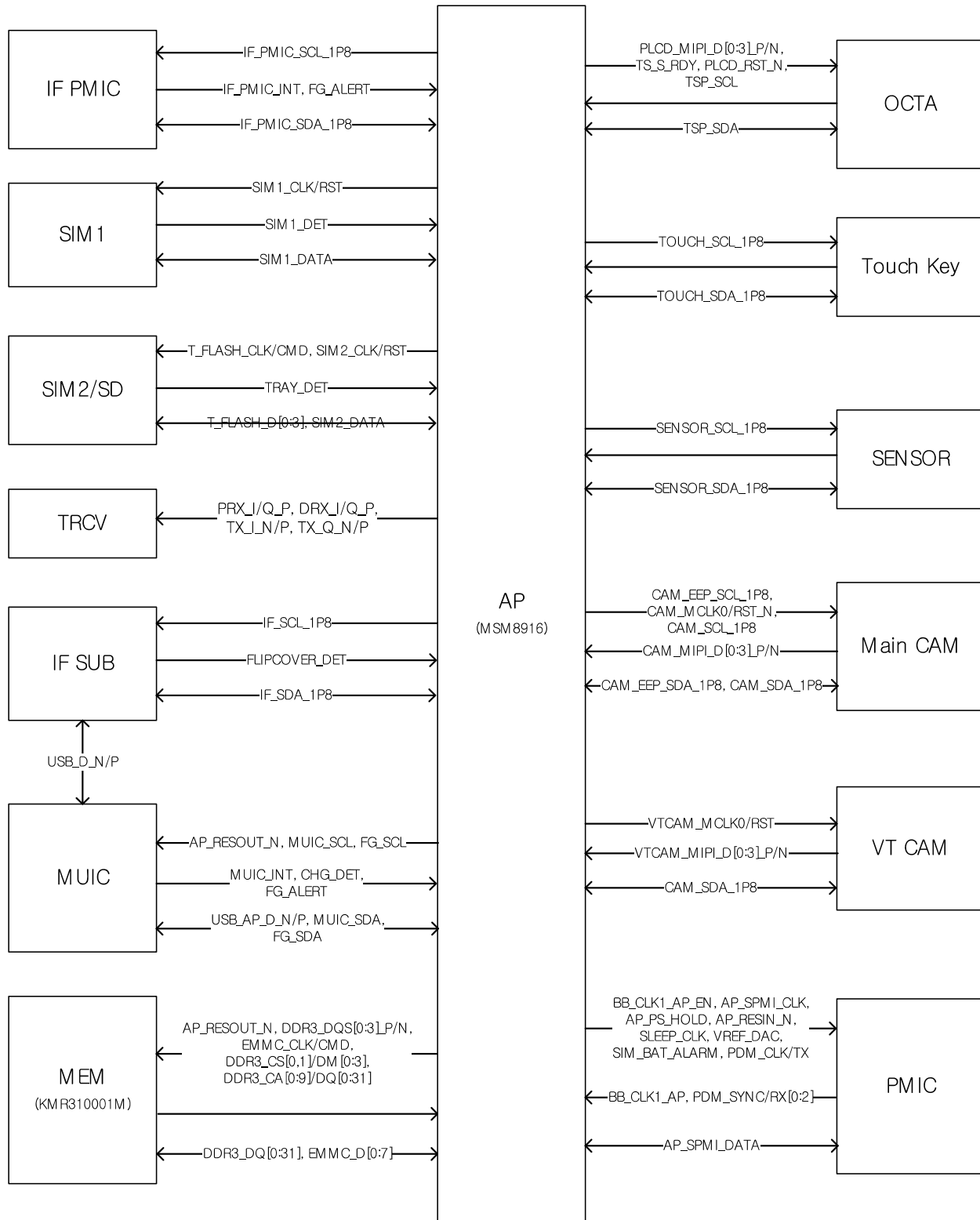

8-2. PCB Diagrams
8-2-1. Main PCB Top

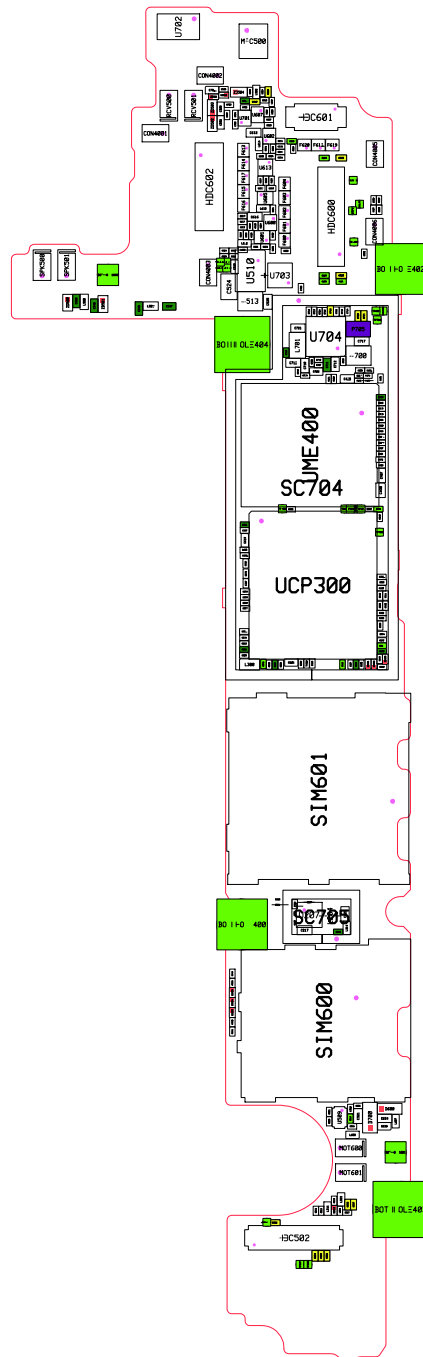

8-2-2. Bottom

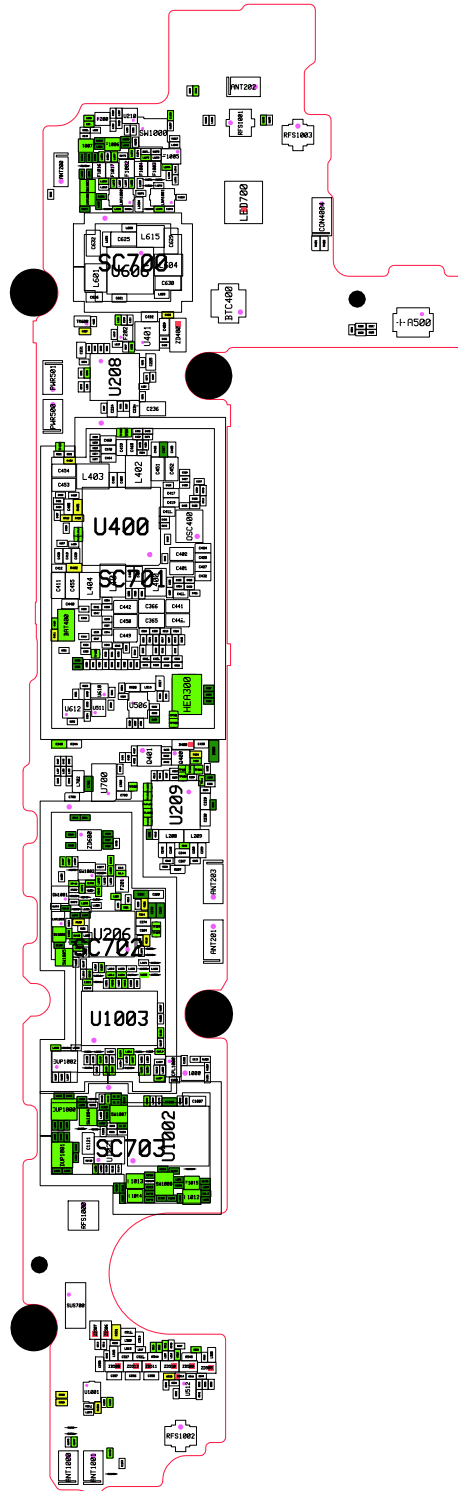

8-2-3. Equipments

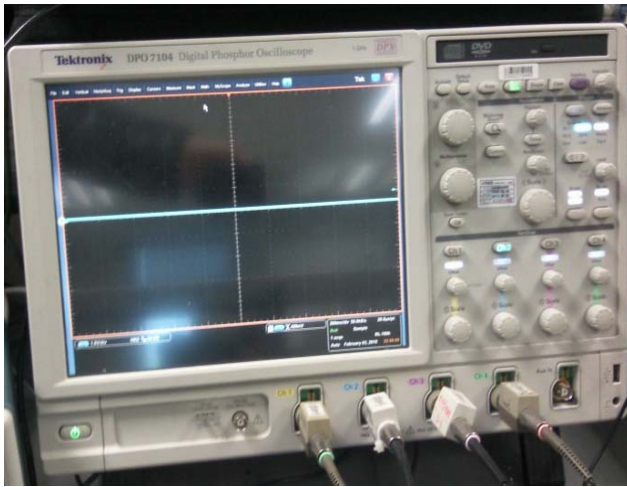

↑ Oscilloscope



↑ Digital Multimeter



↑ Power Supply



↑ + driver, ESD Safe Tweezer

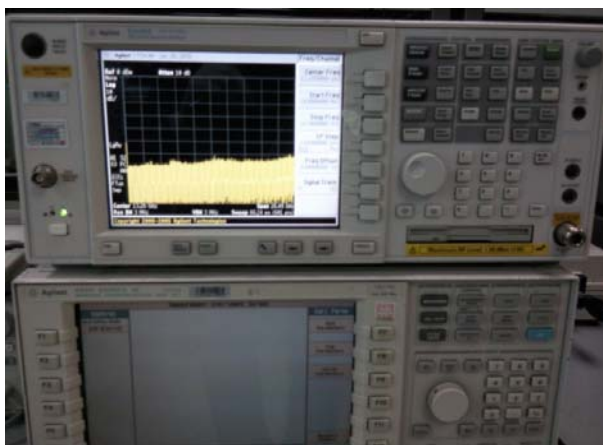

↑ 8960 & Spectrum Analyzer



↑ Soldering iron

8-3. Flow Chart of Troubleshooting

8-3-1. Power On

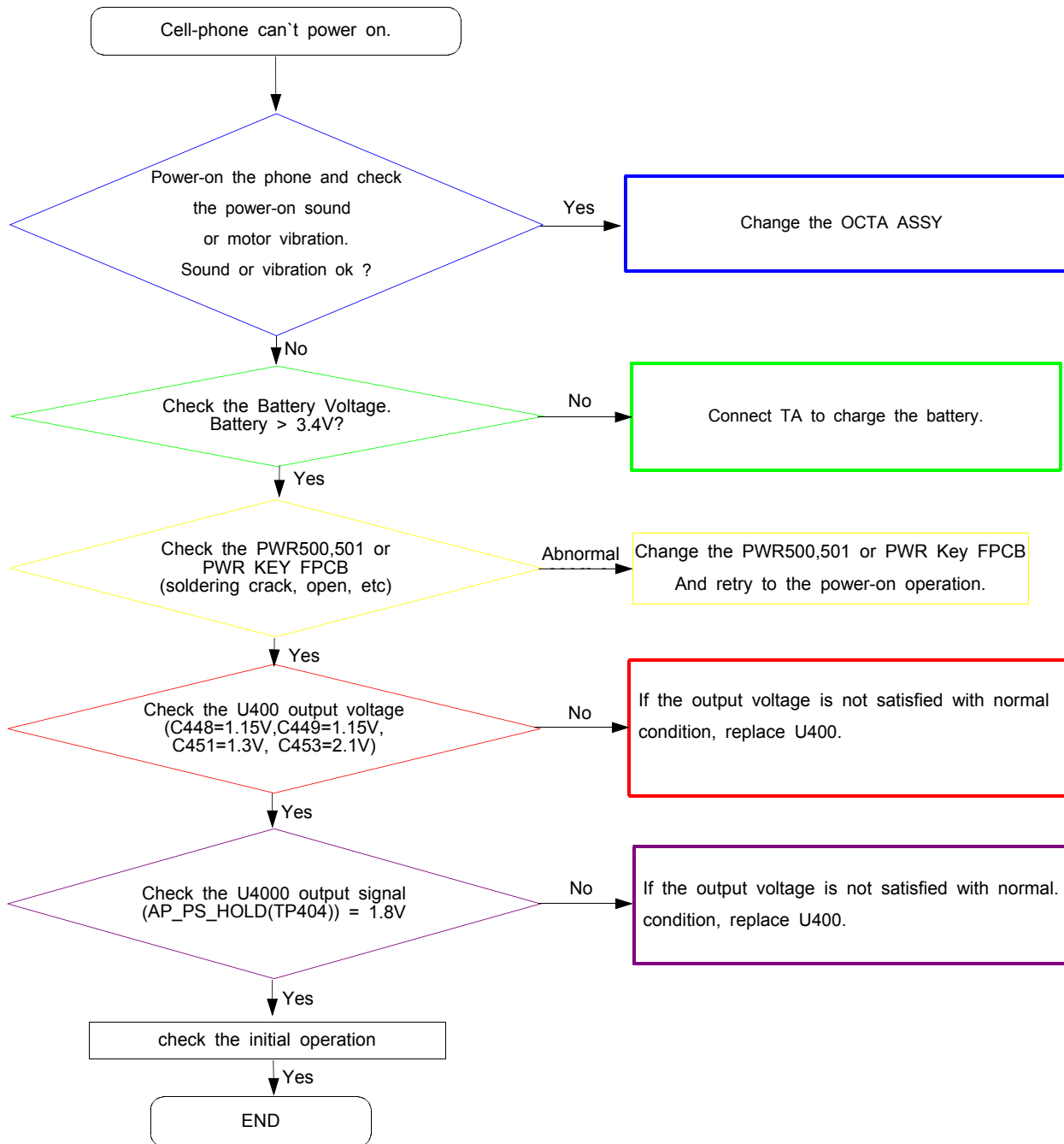

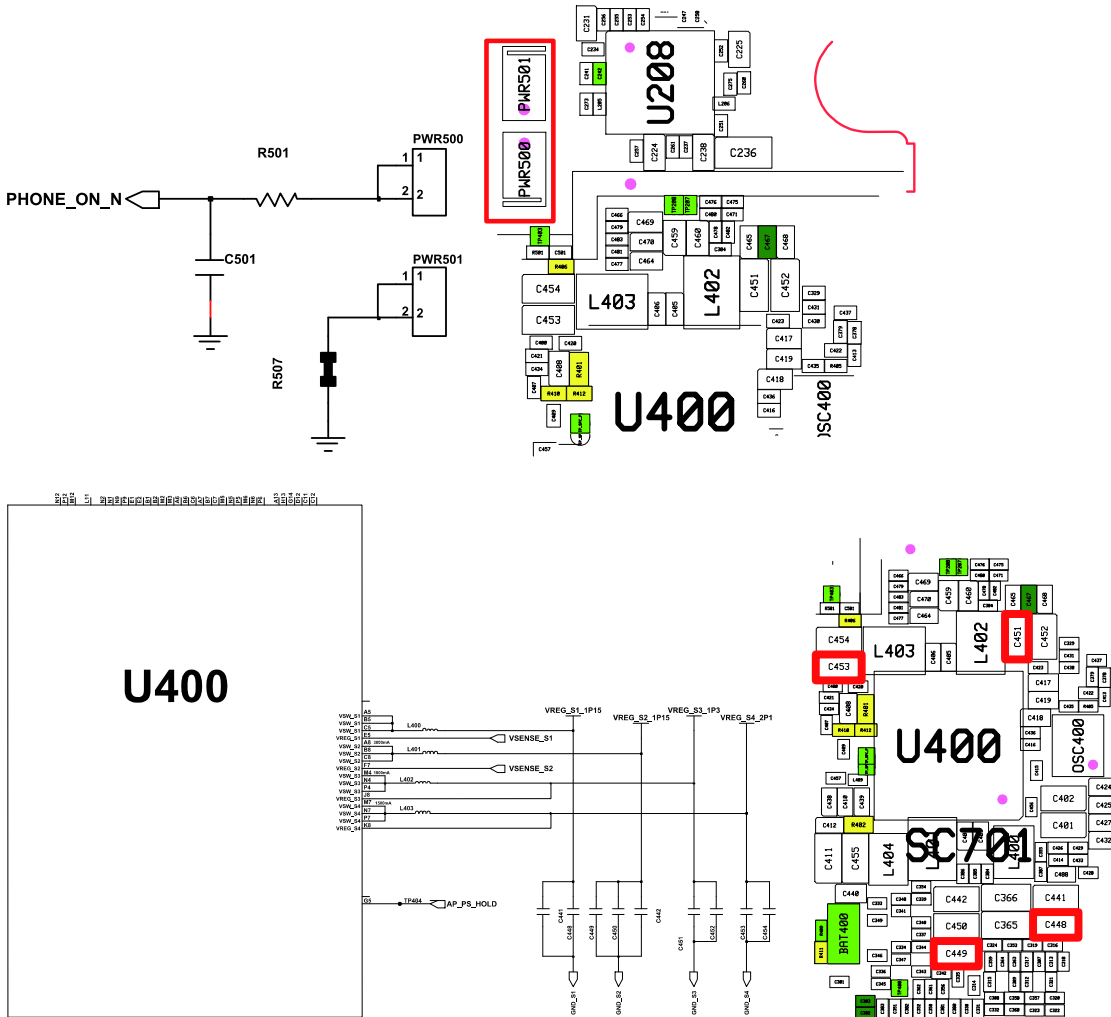

8-3-2. Initial

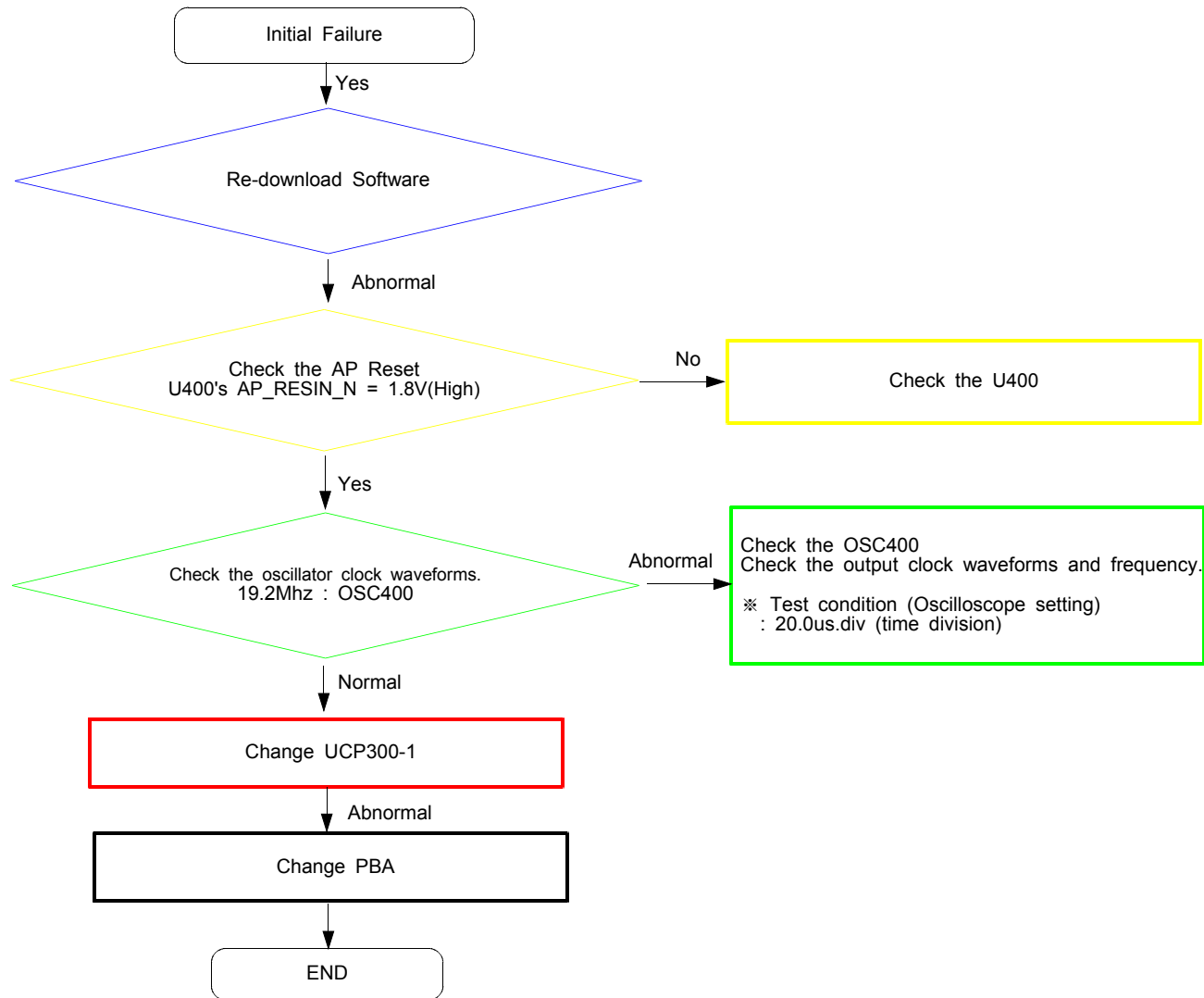

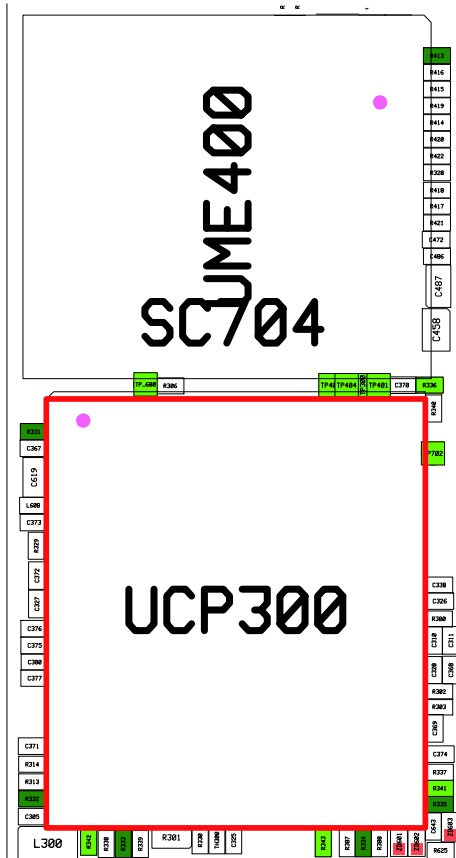
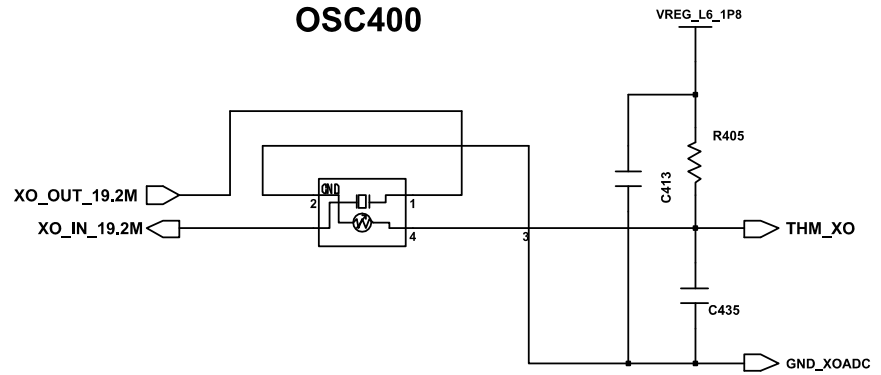
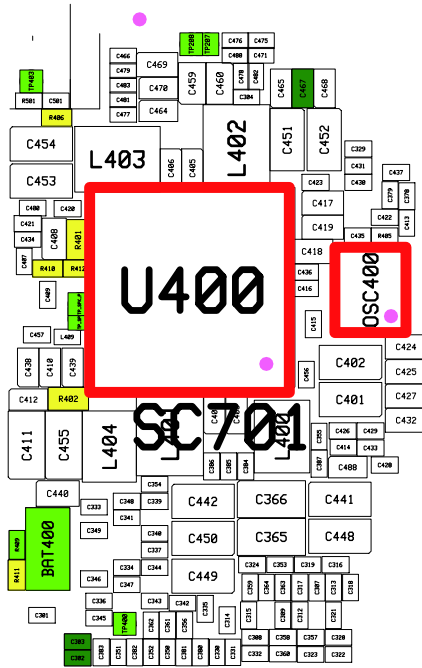

8-3-3. No Service

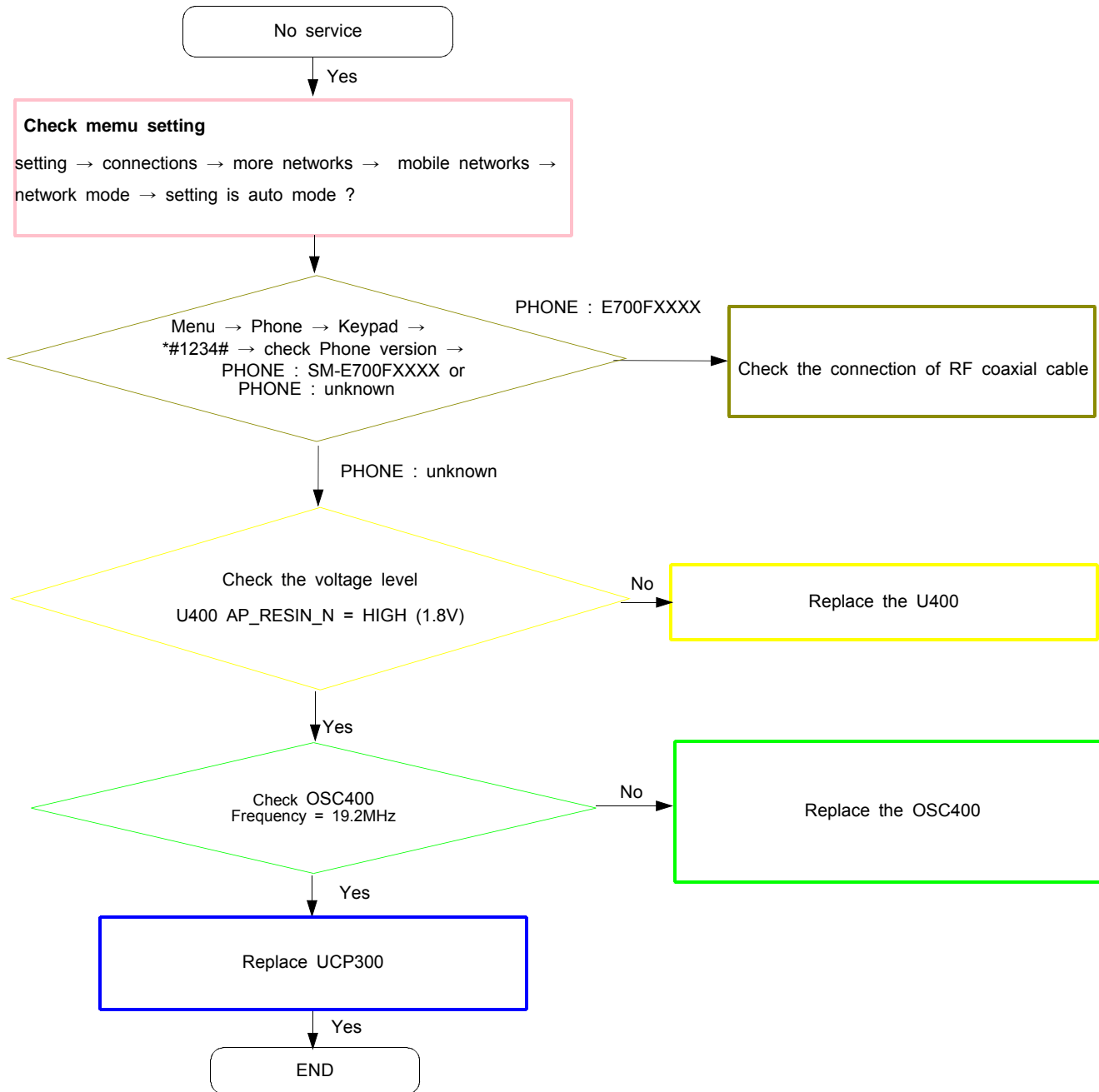

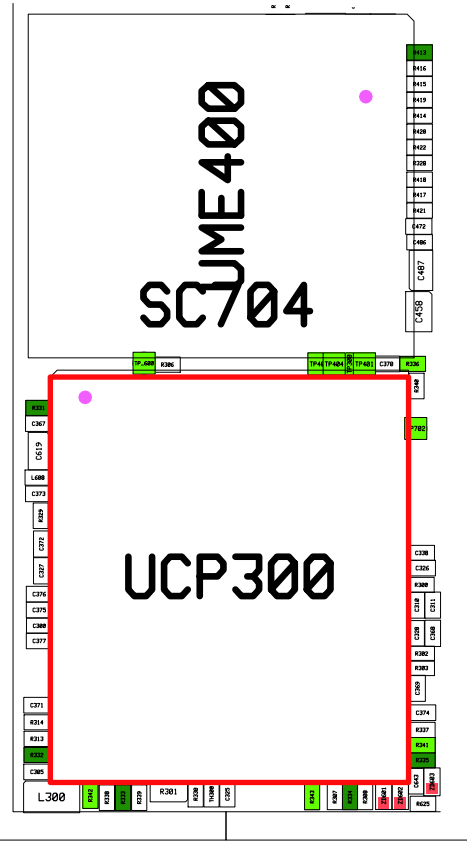
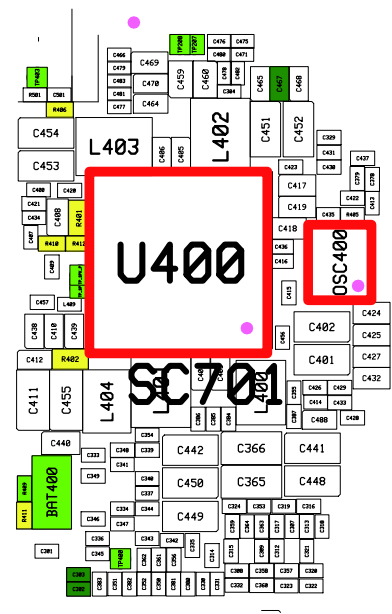
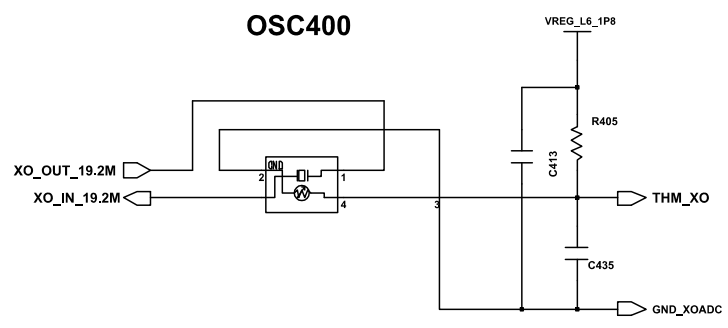

8-3-4. SIM1 Part

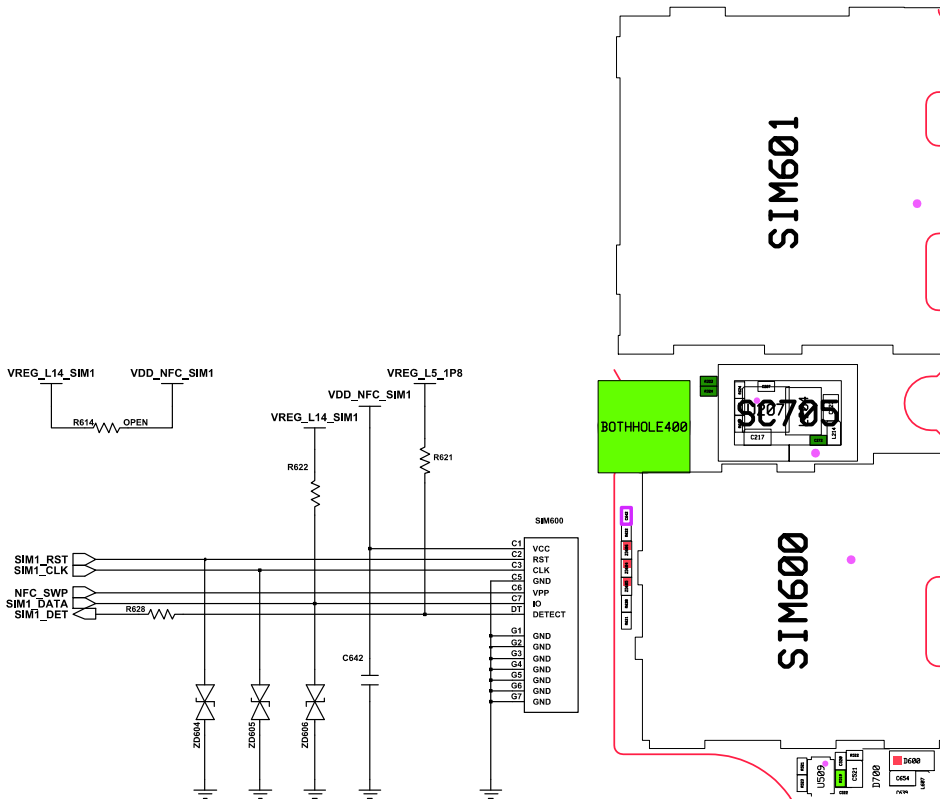
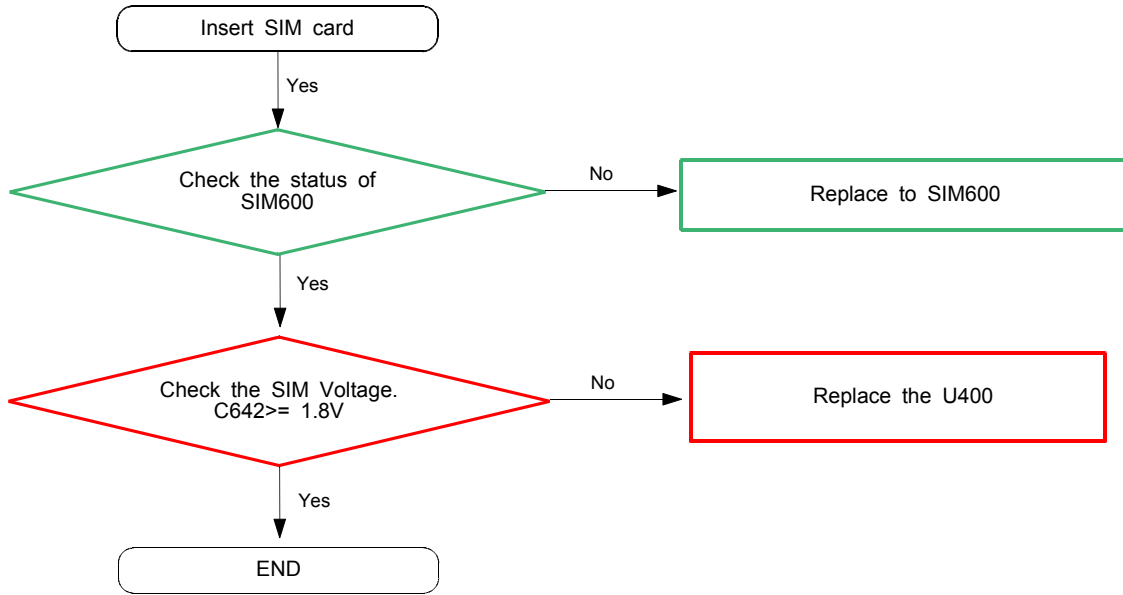

8-3-5. Hybrid Socket Part

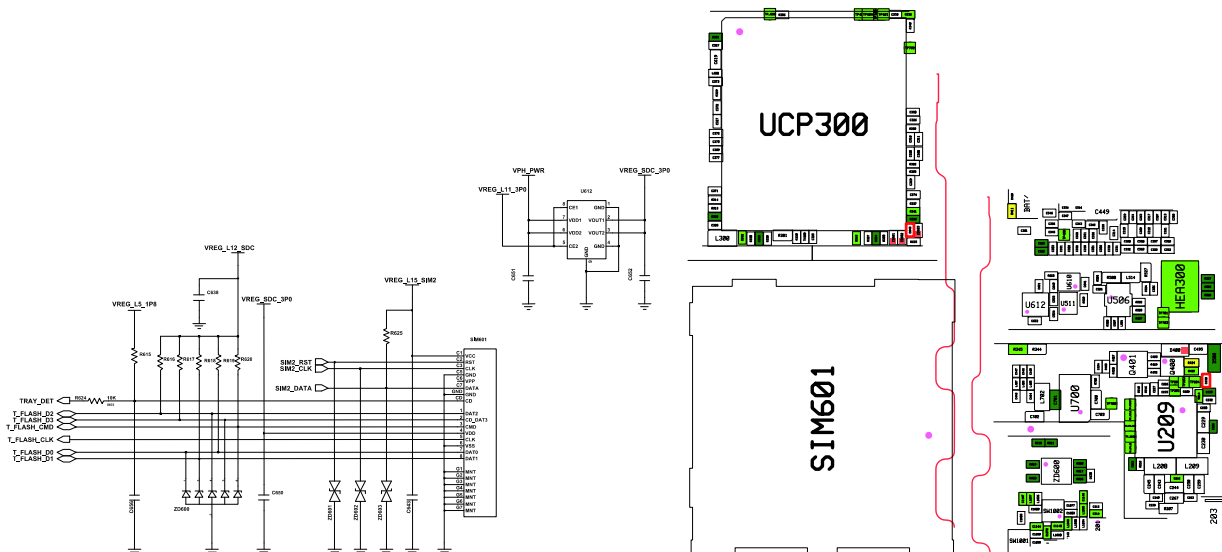
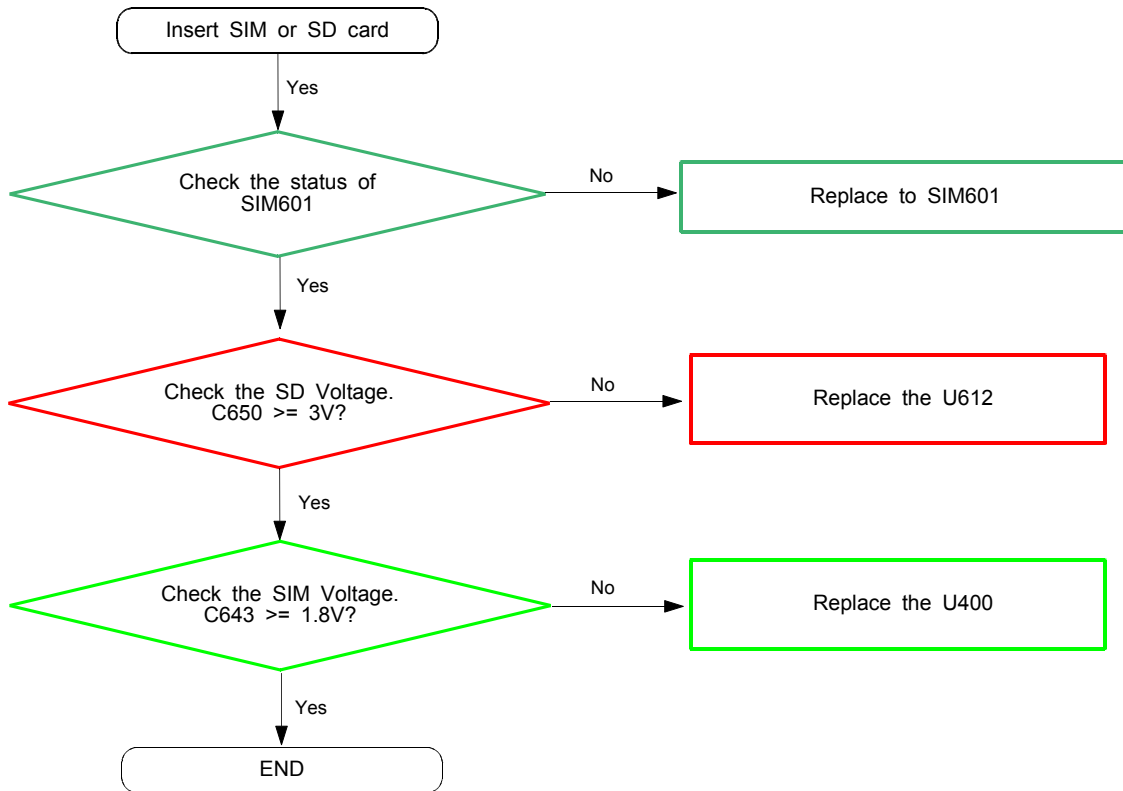

8-3-6. Charging Part

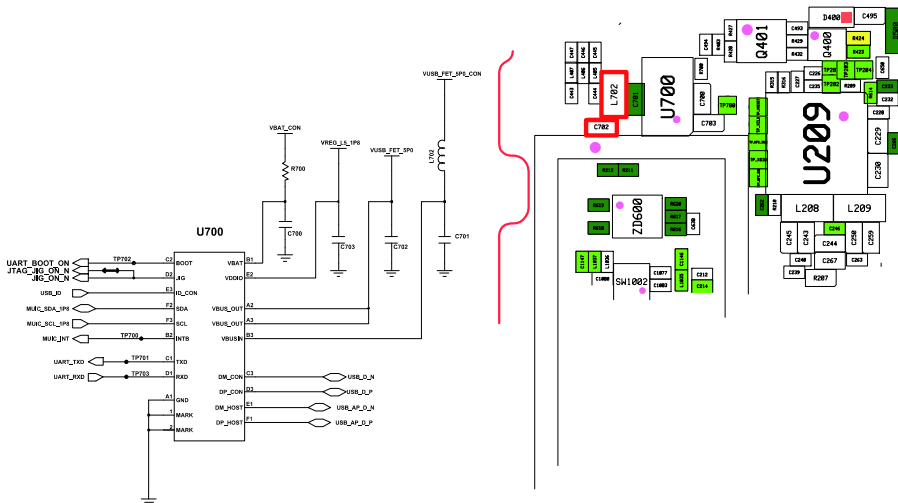
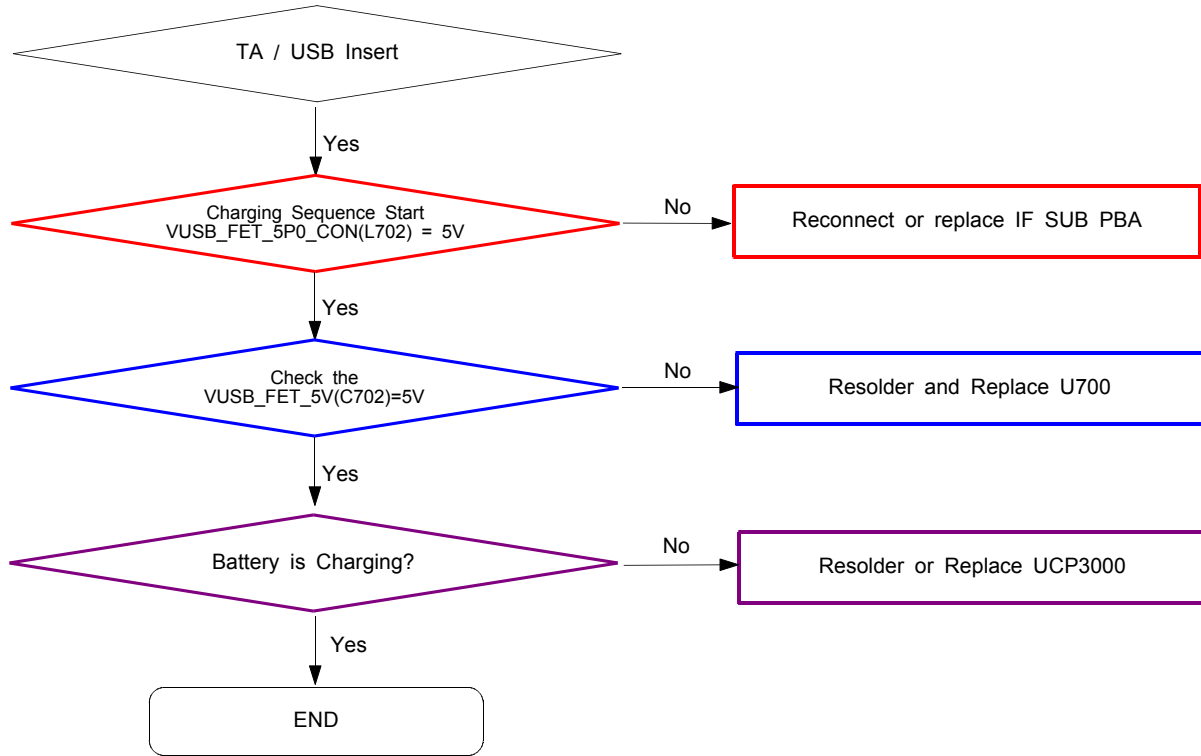

8-3-7. ACC Sensor

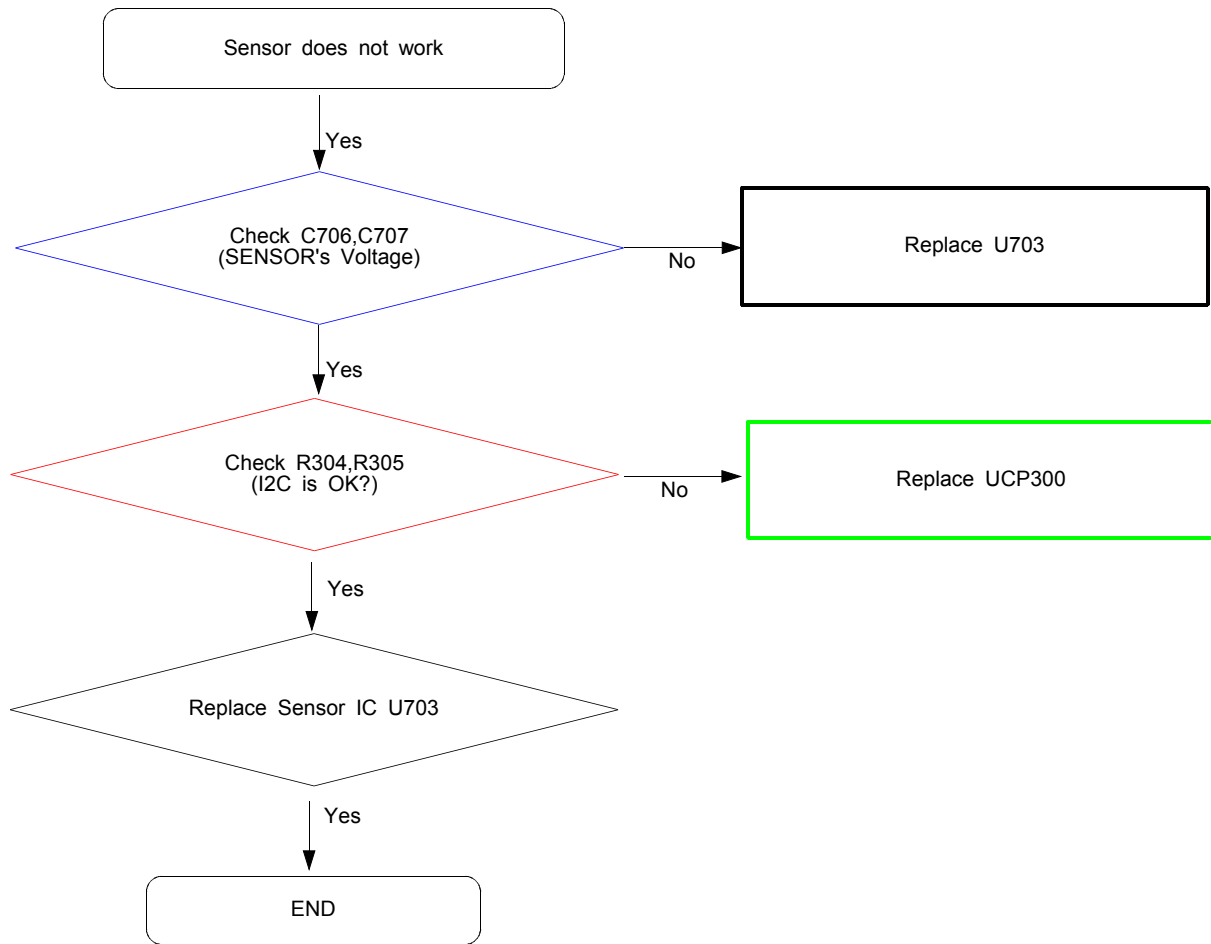

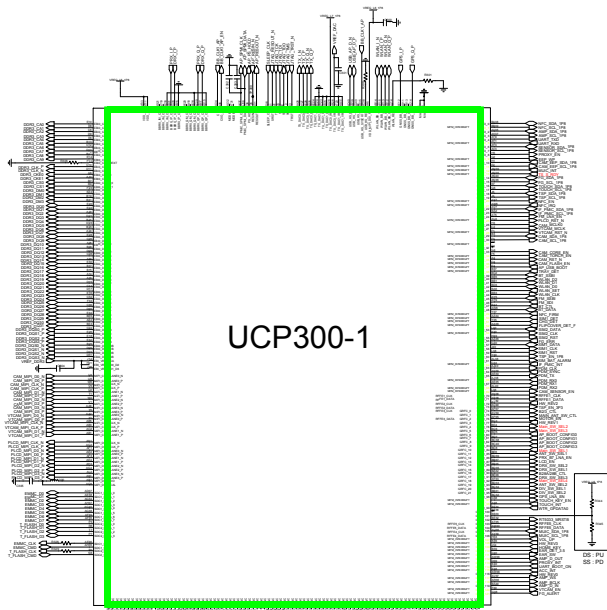
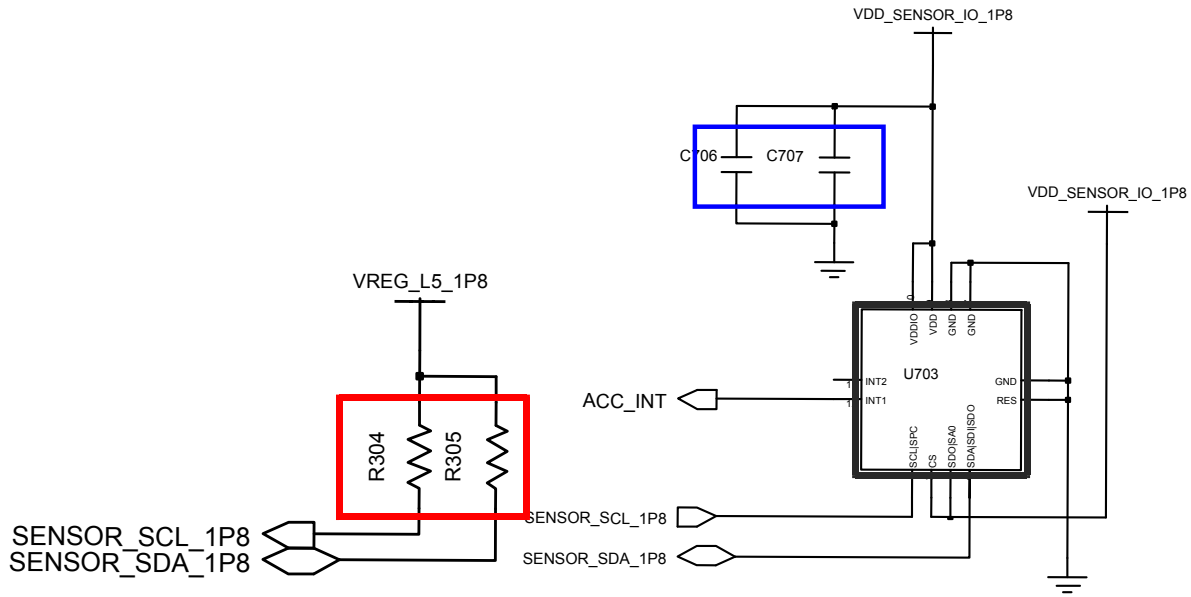

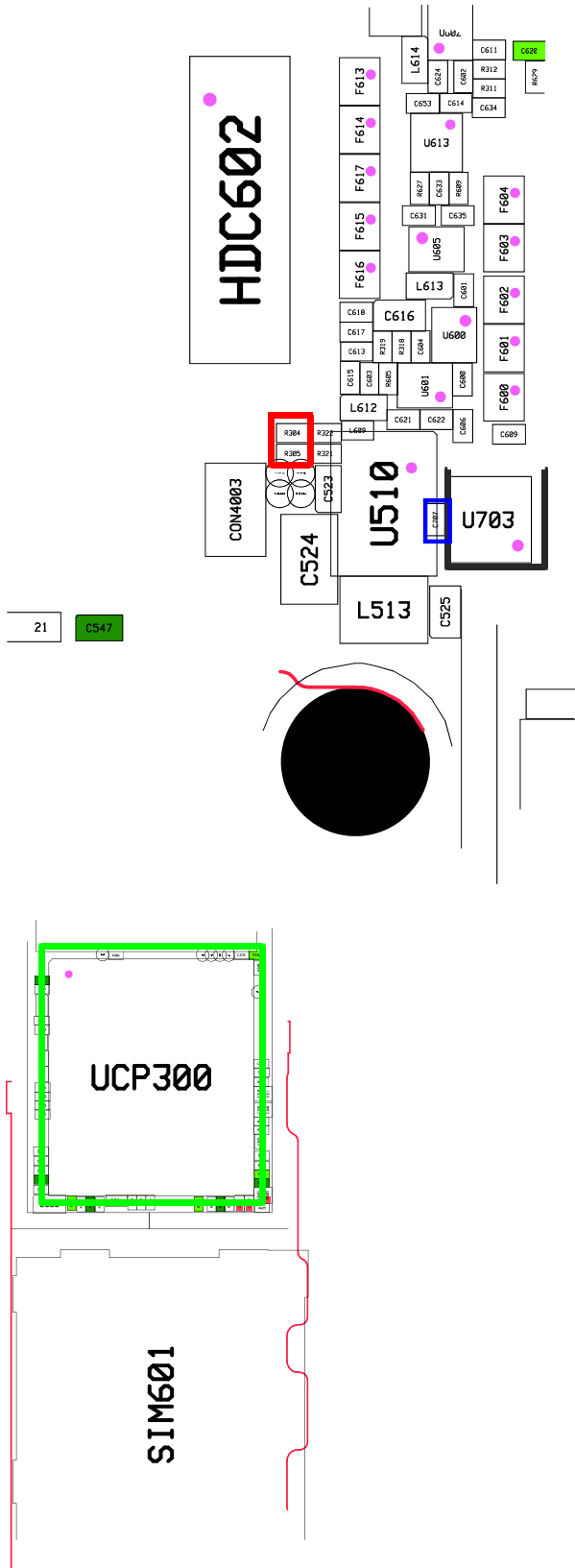

8-3-8. Proximity Detector

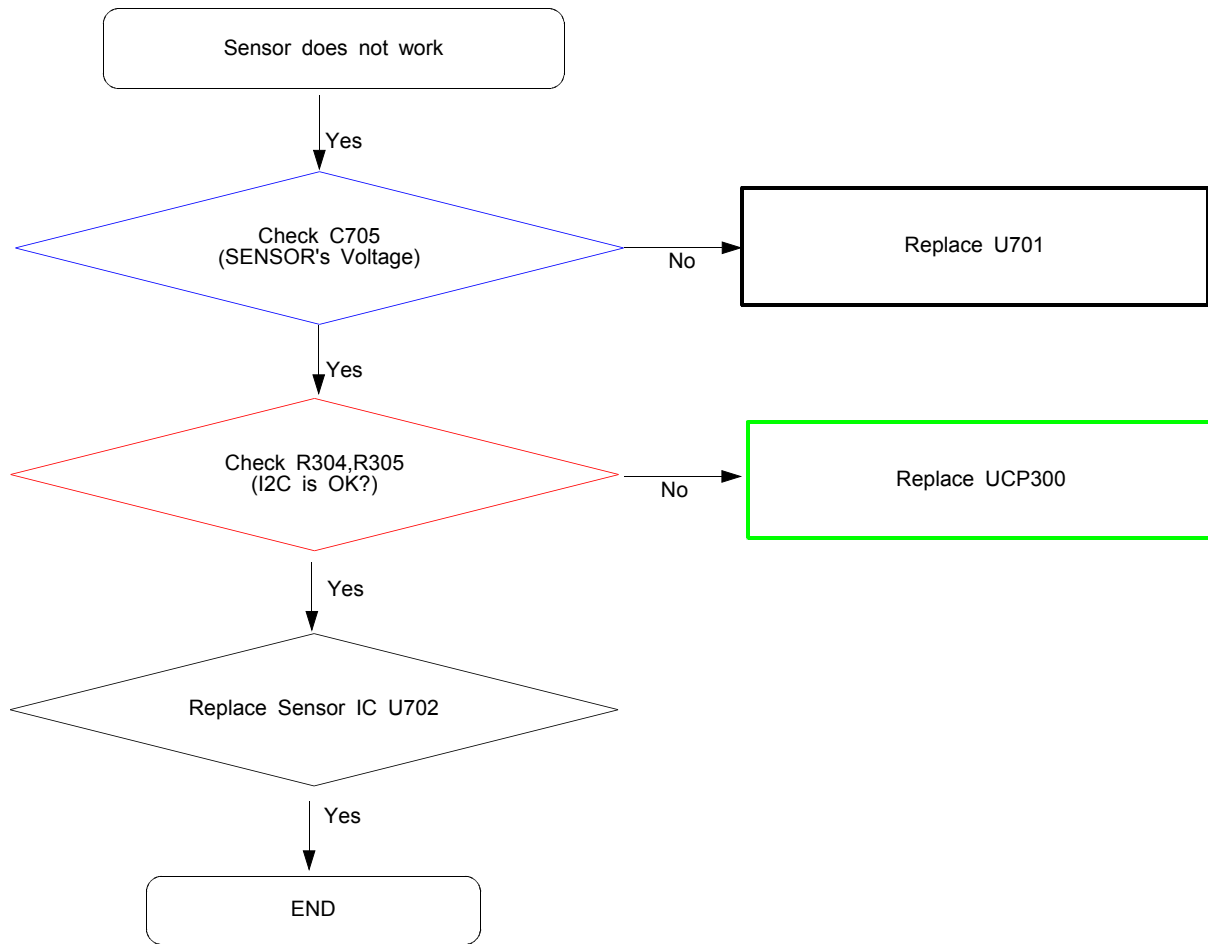

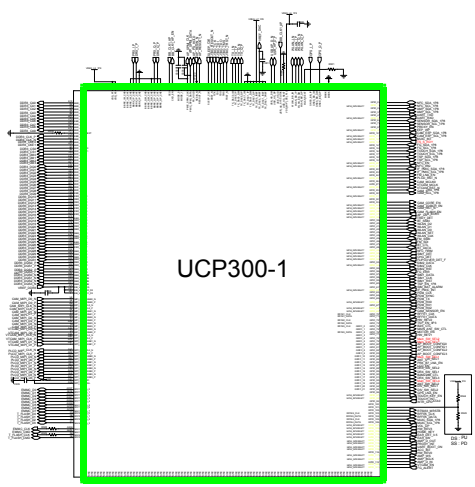
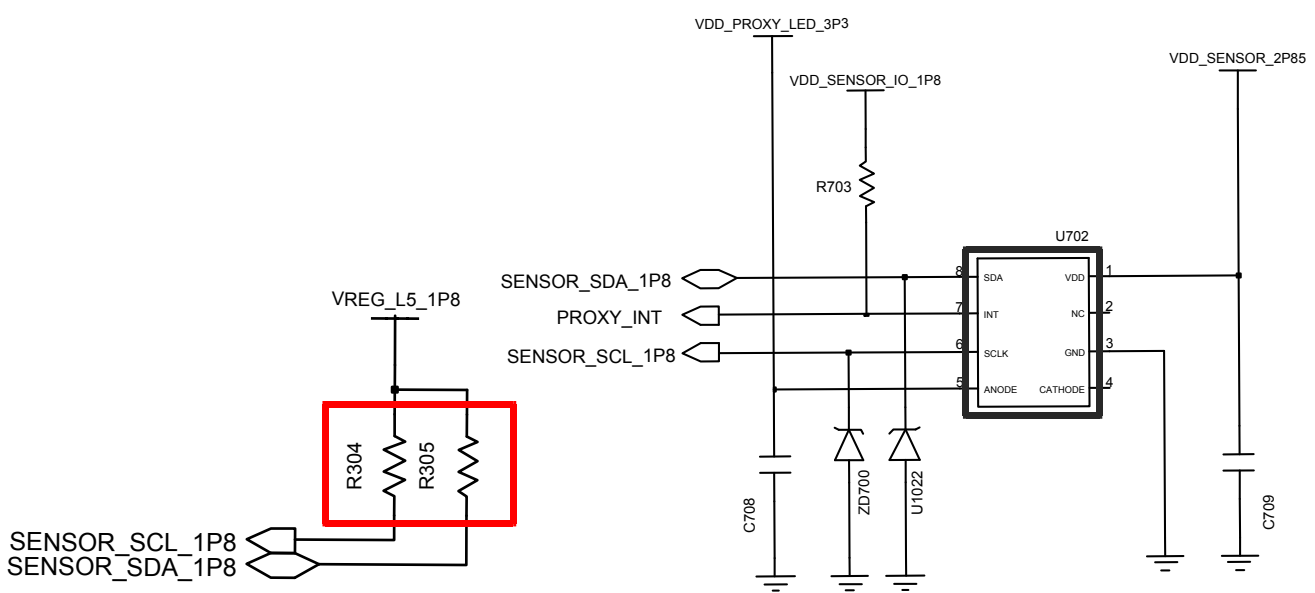
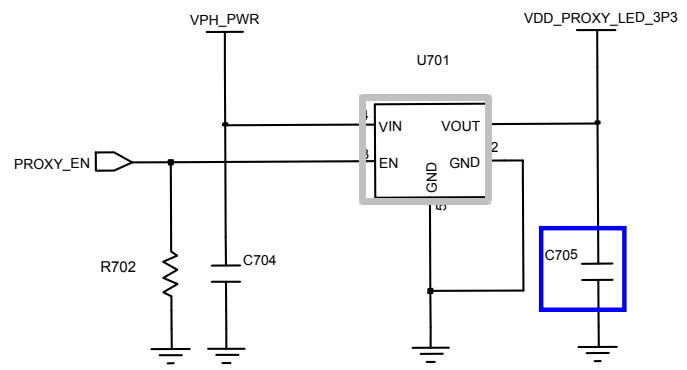

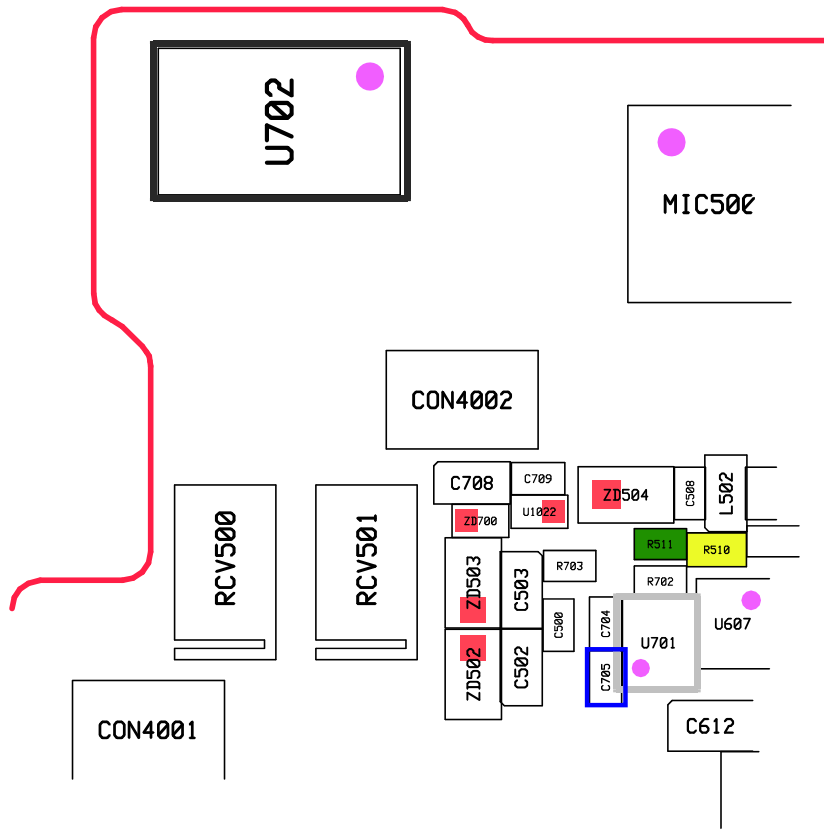

21 C547

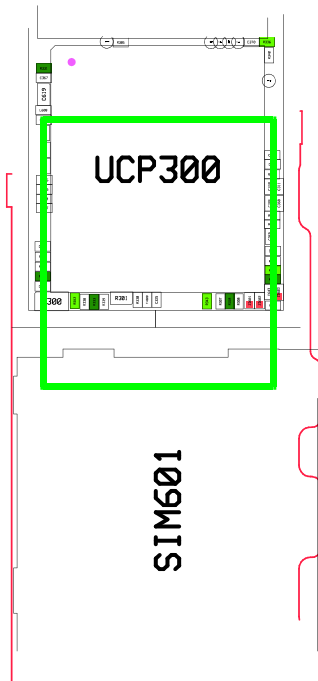
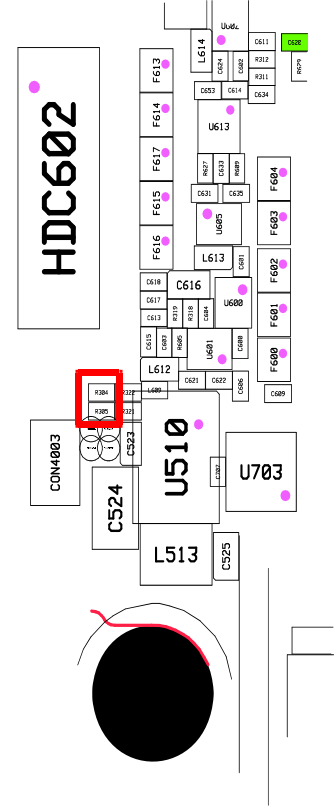

8-3-9. Speaker Part

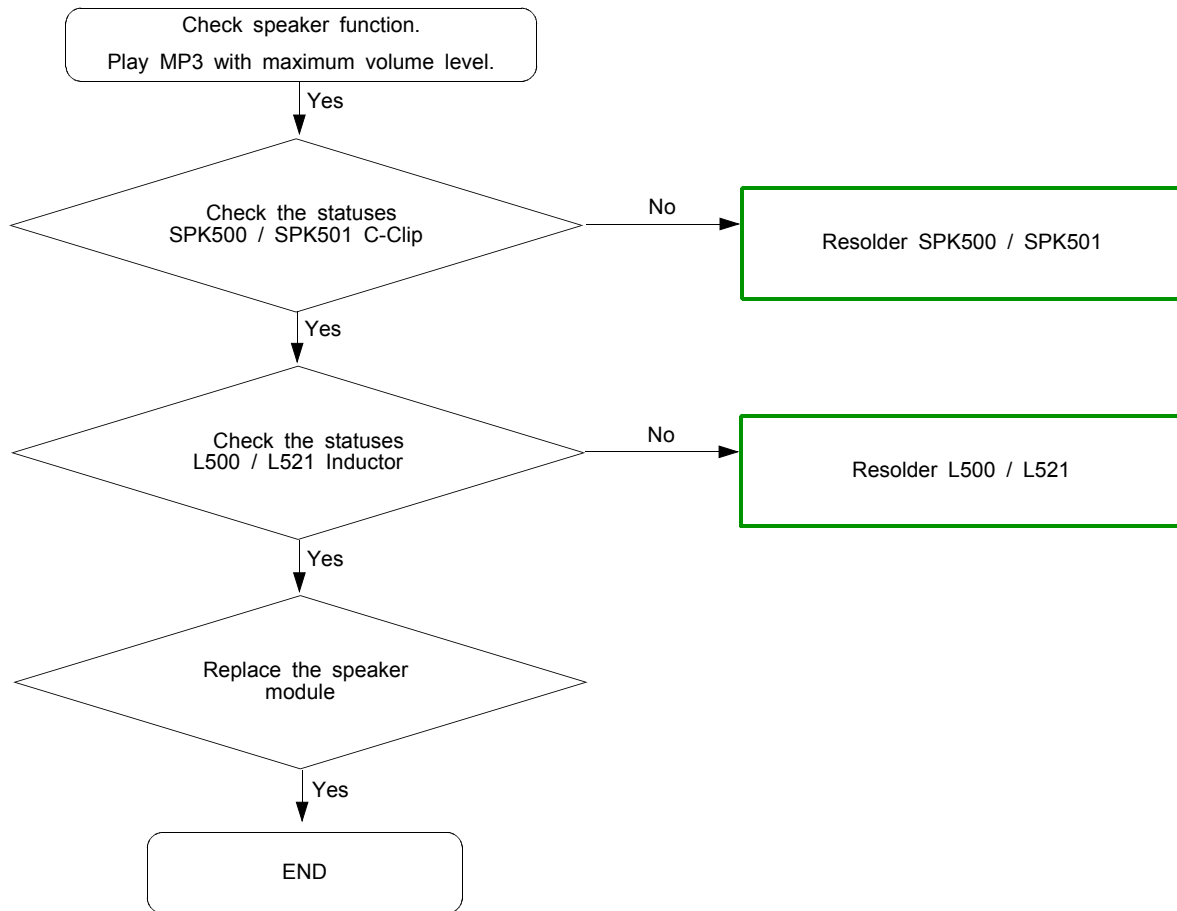

..

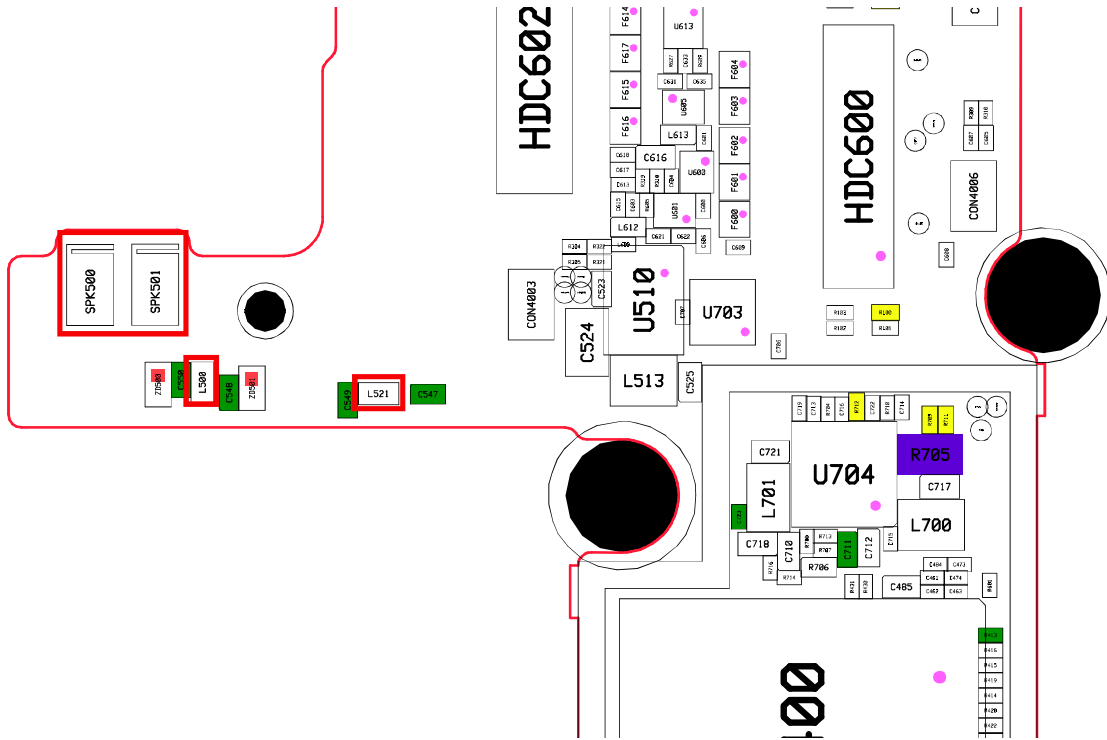
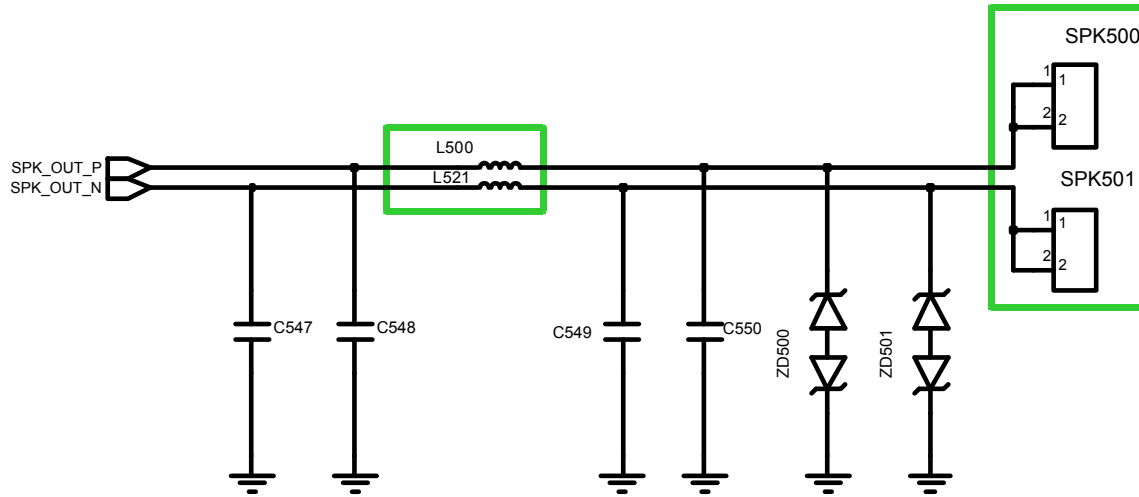

8-3-10. Receiver Part

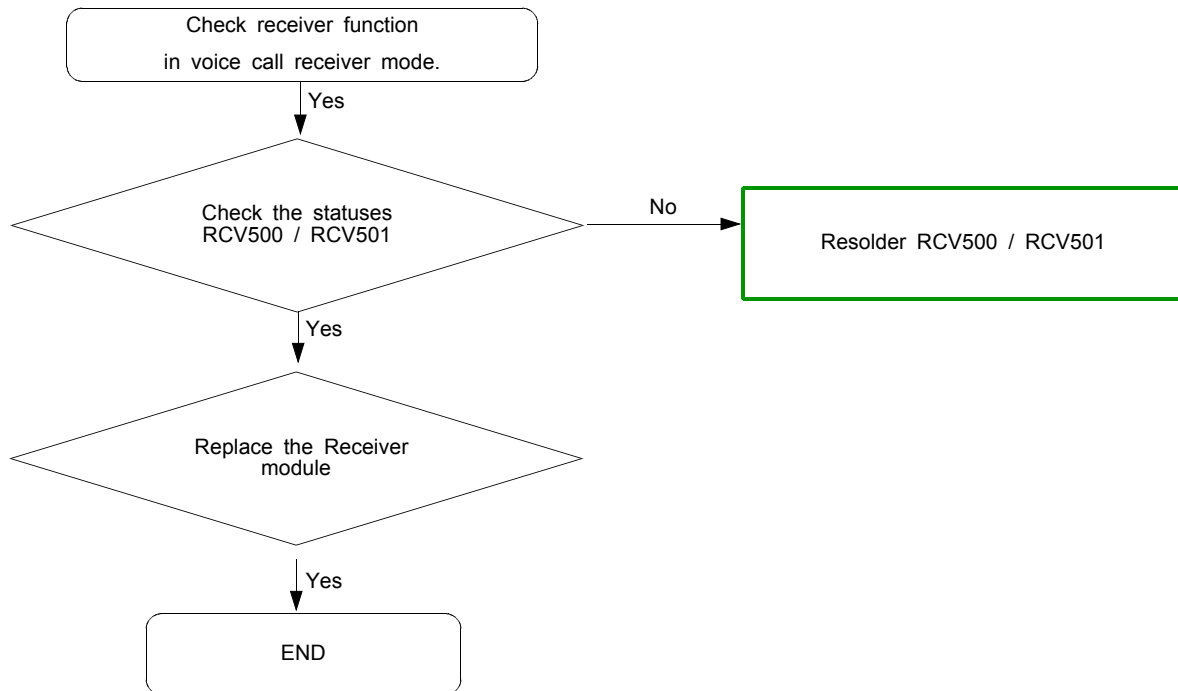

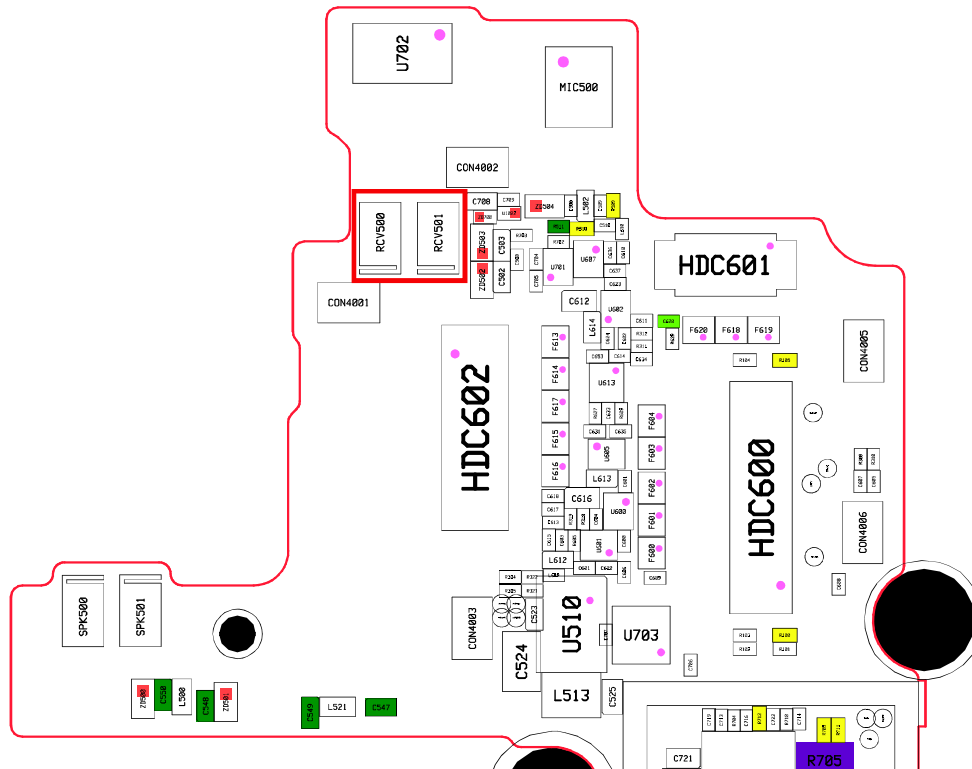
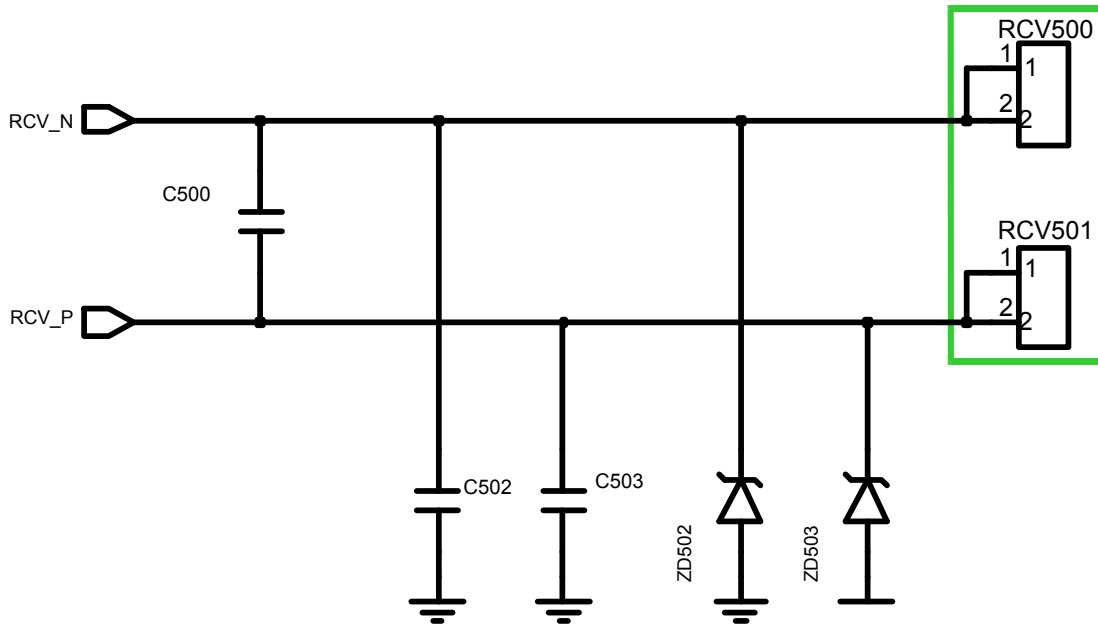

8-3-11. BT Part

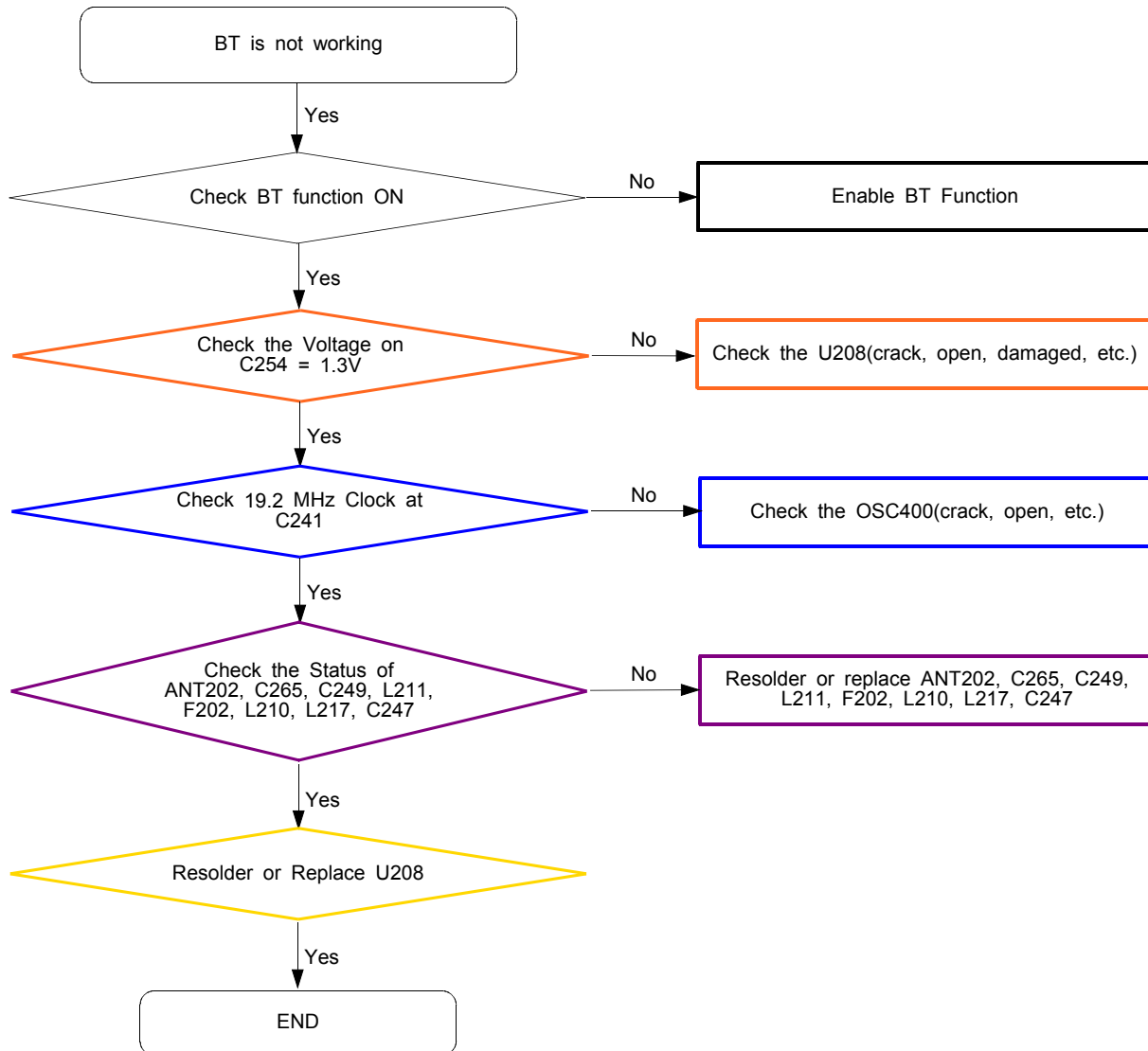

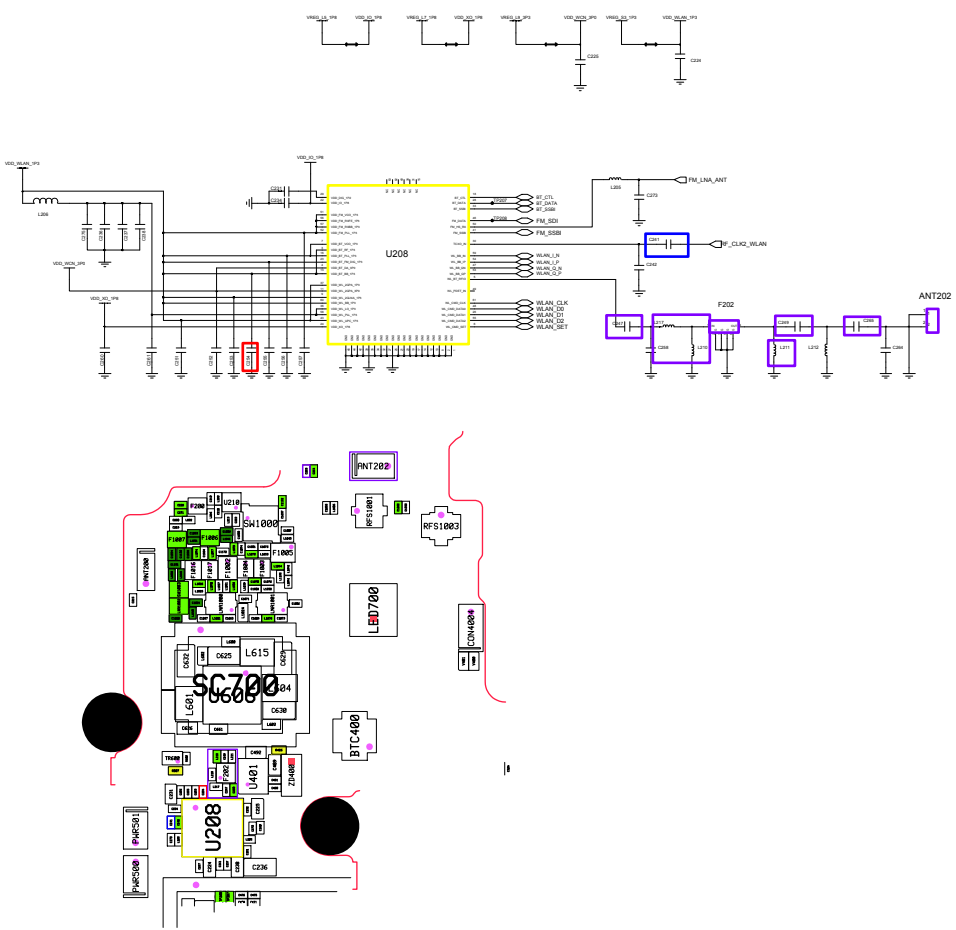

8-3-12. WIFI Part

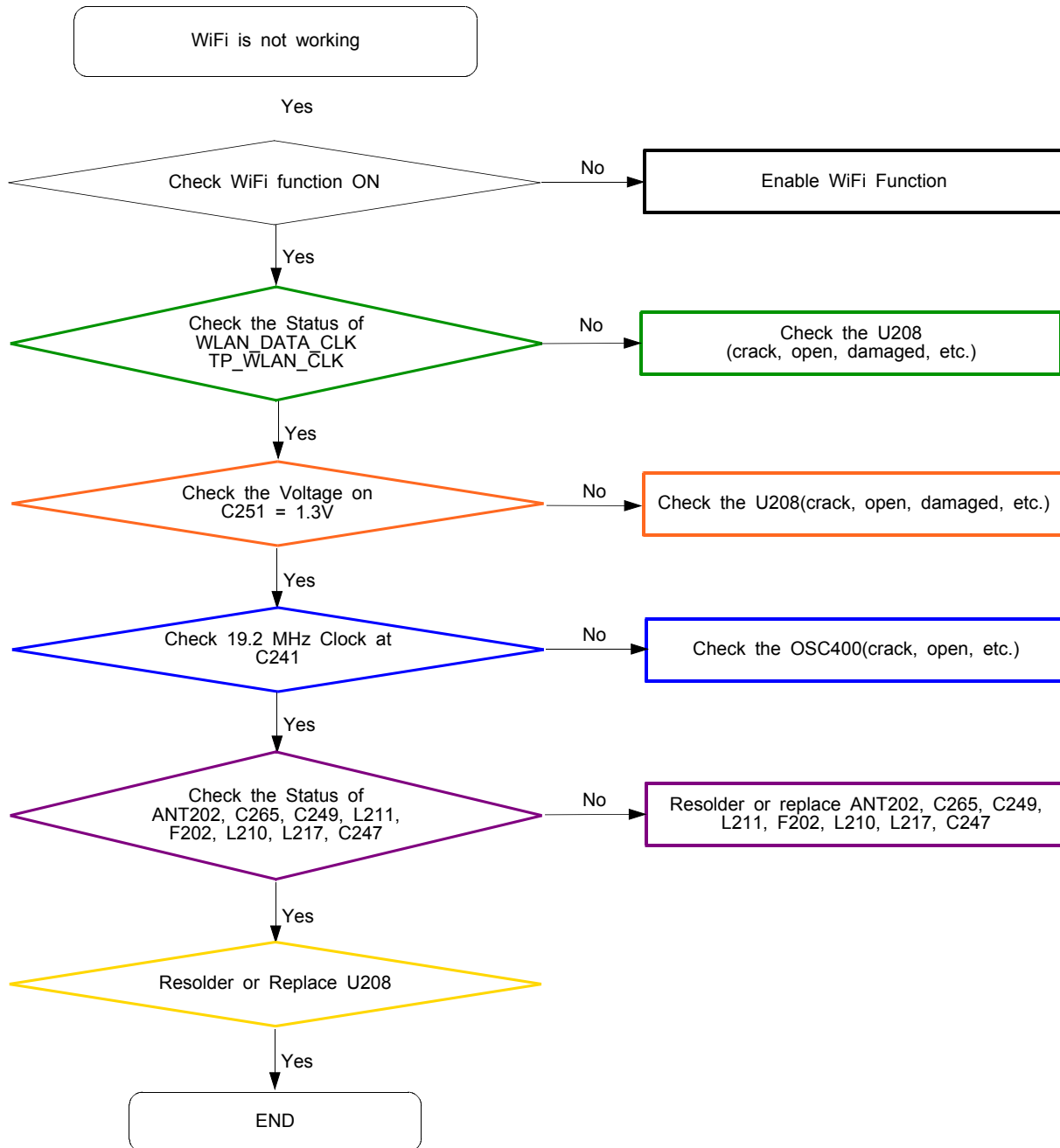

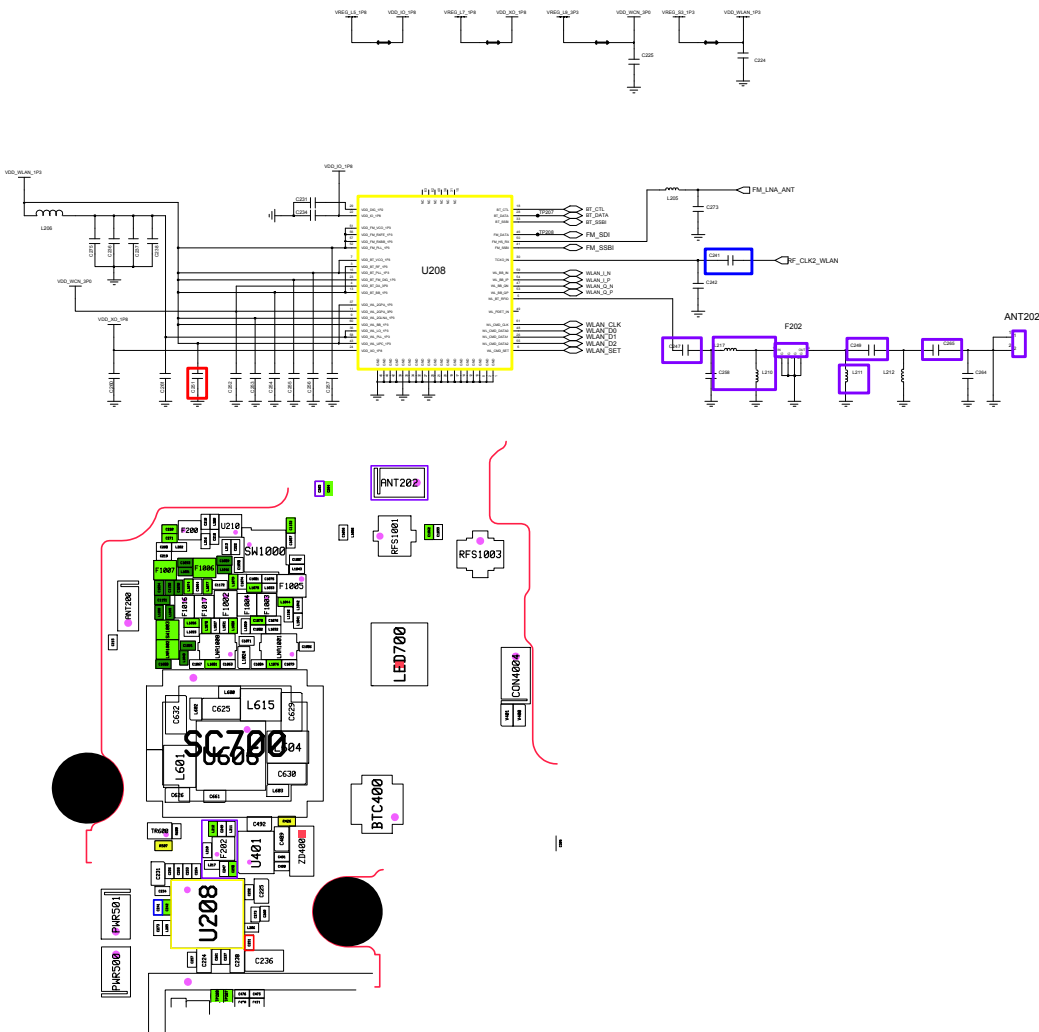

8-3-13. GPS Part

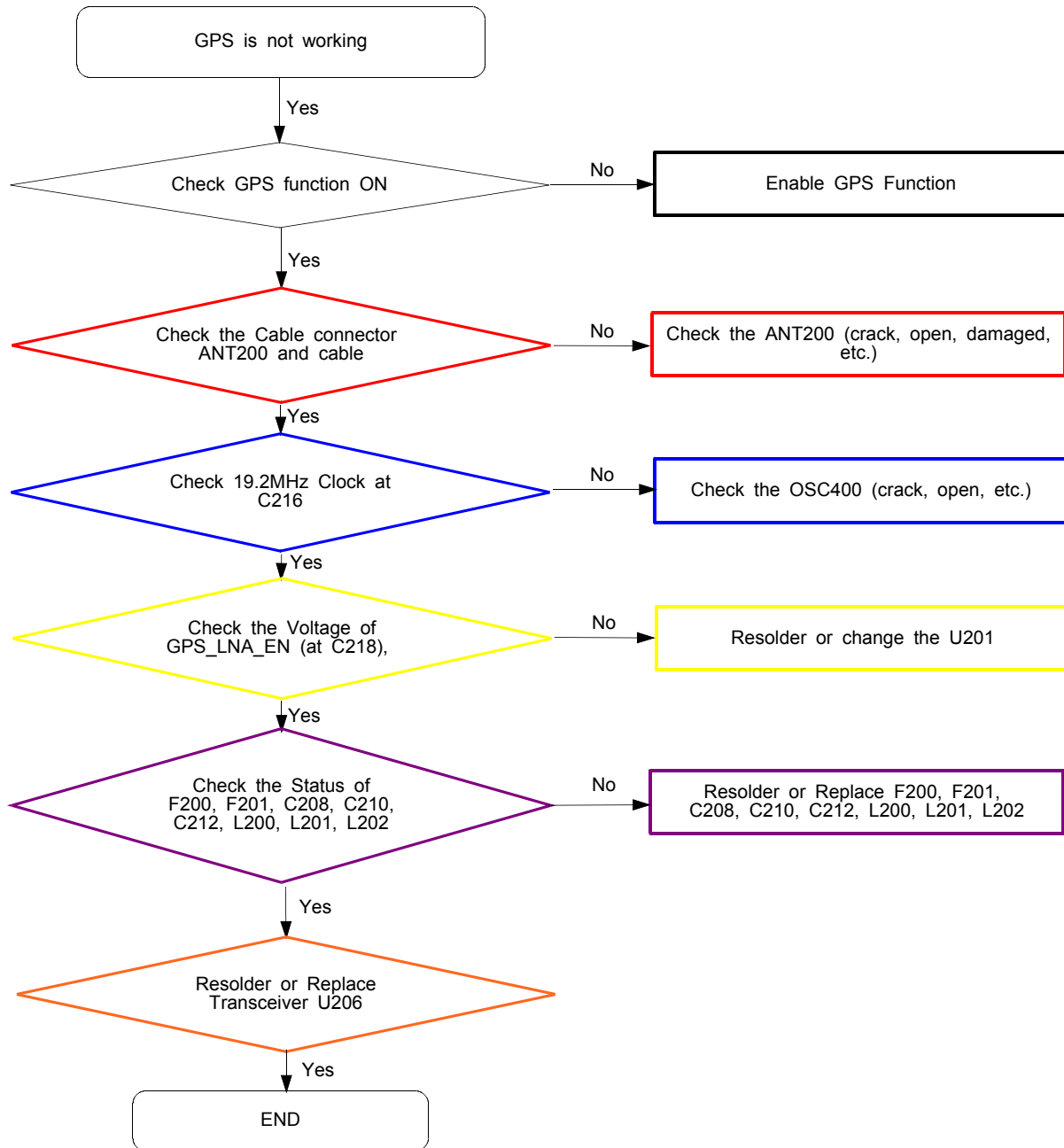

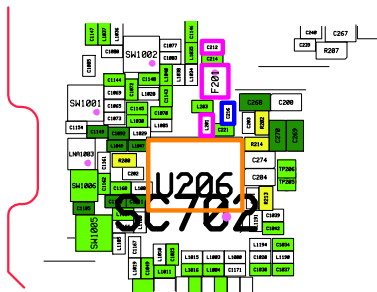
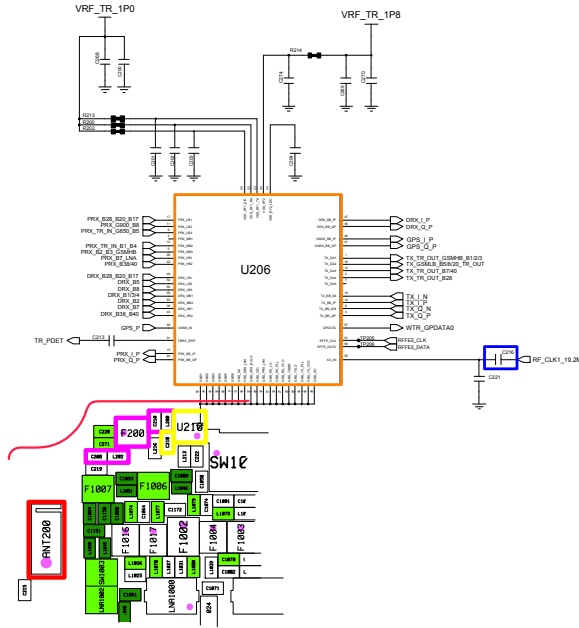
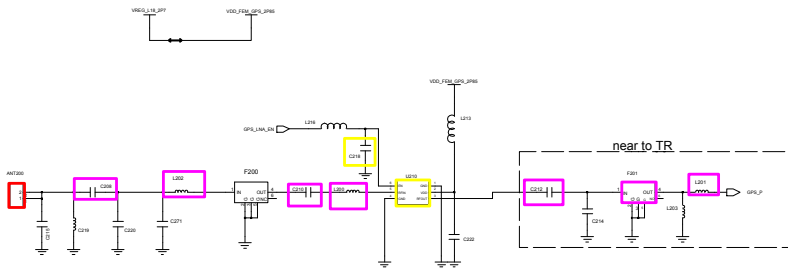

8-3-14. NFC

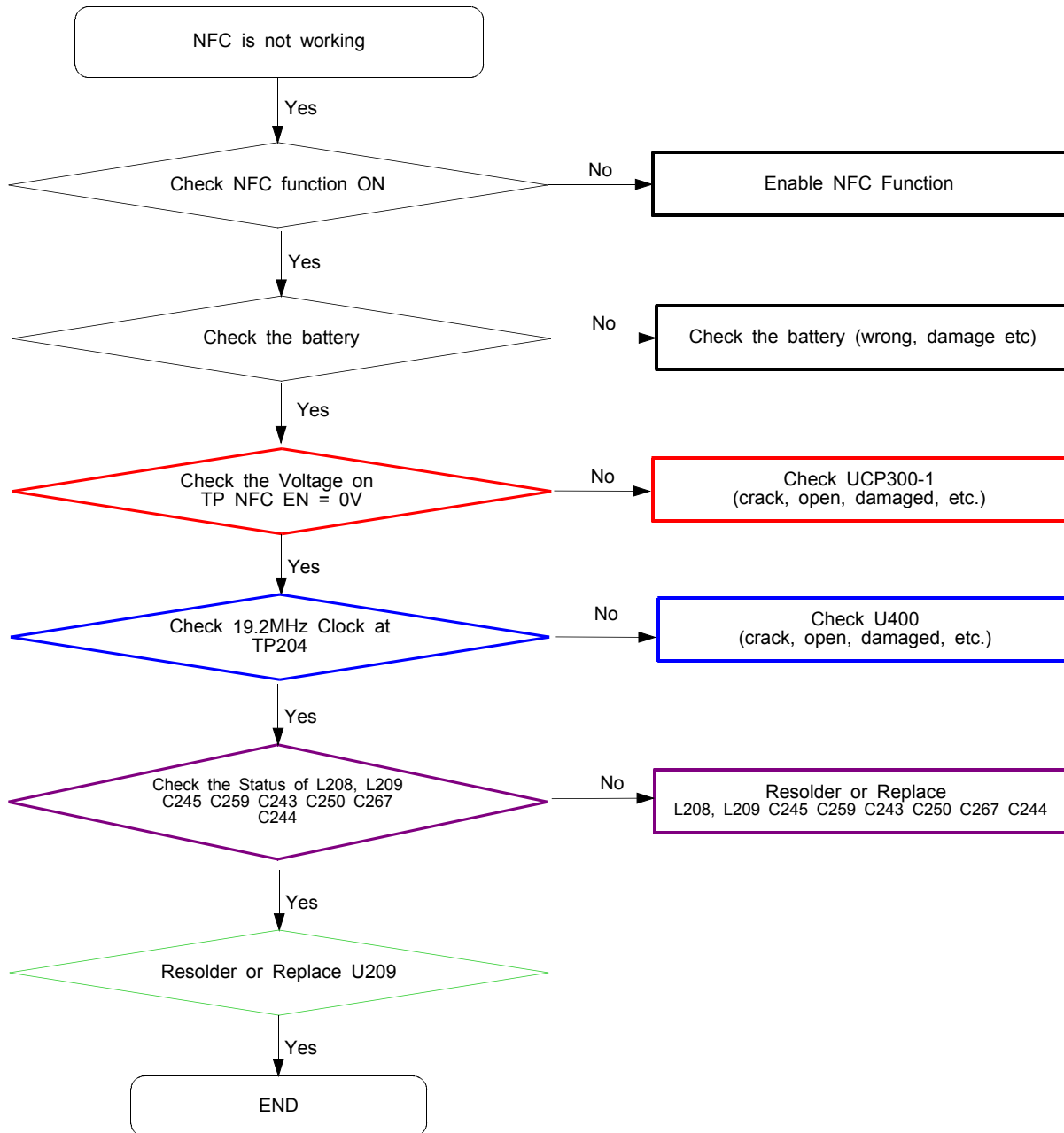

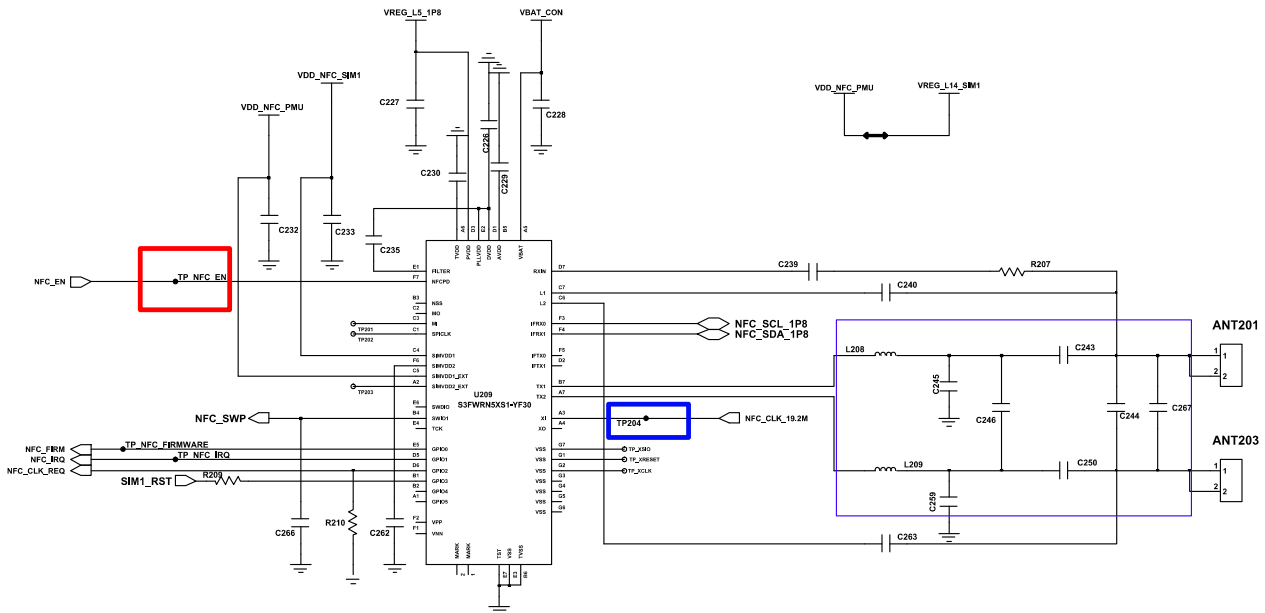

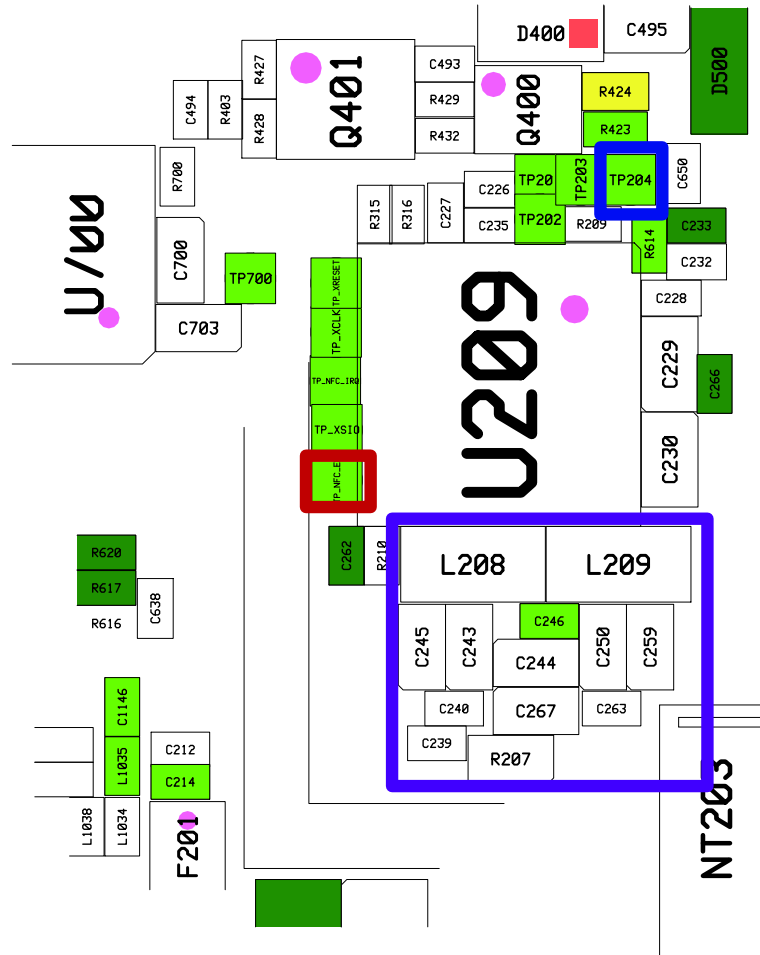

8-3-15. LCD

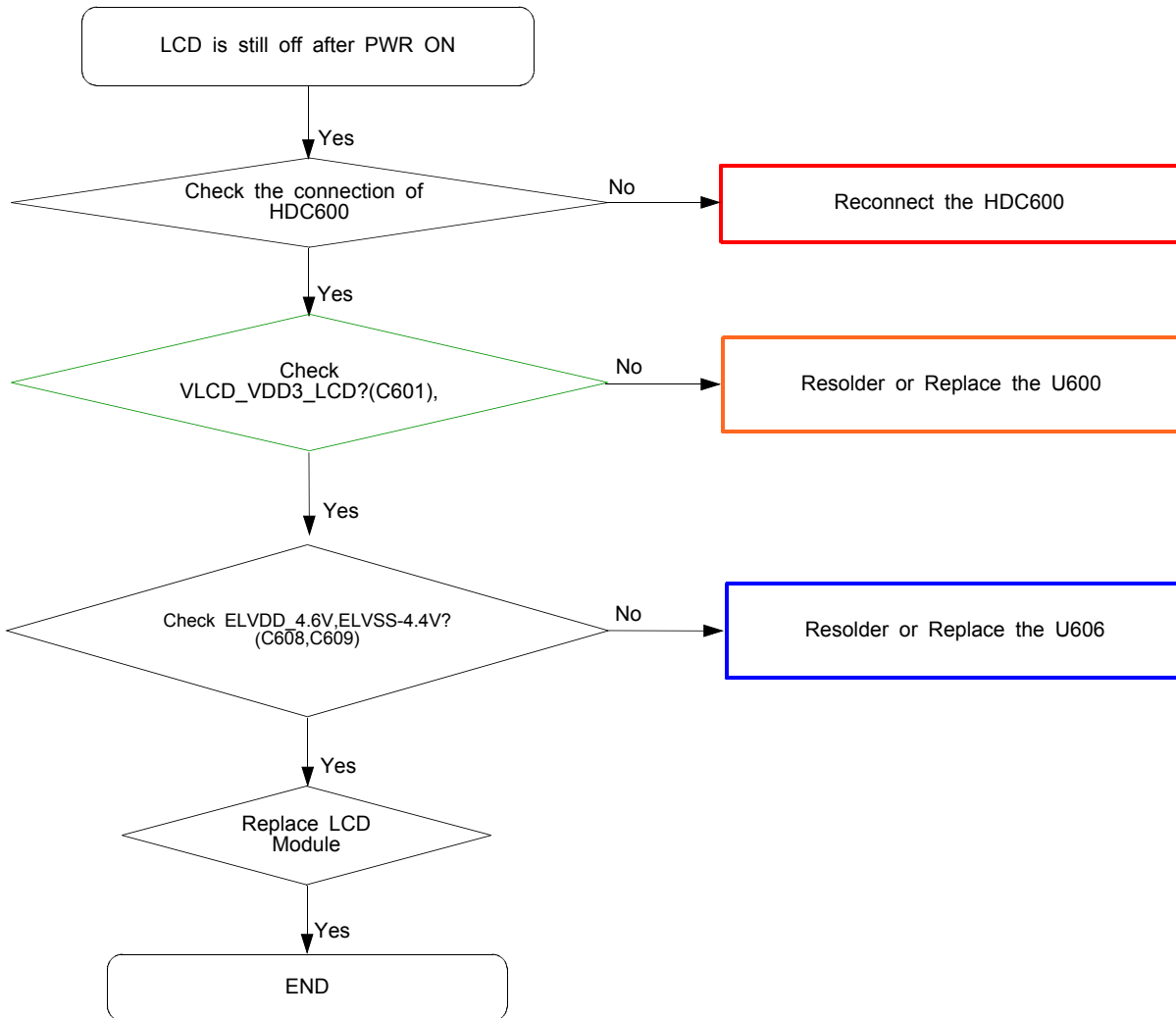

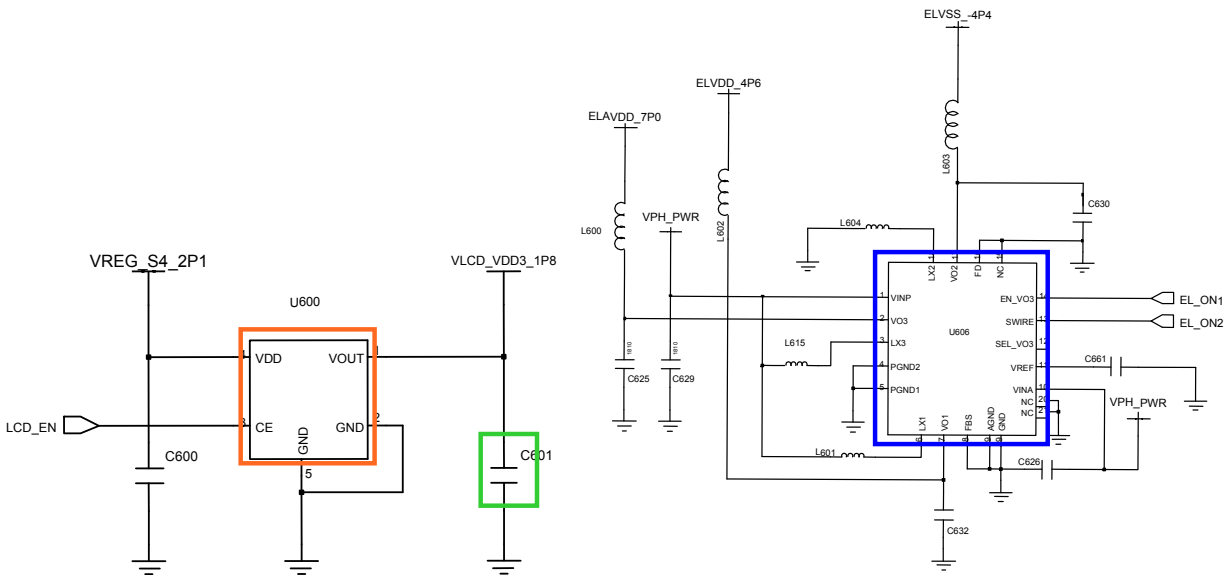
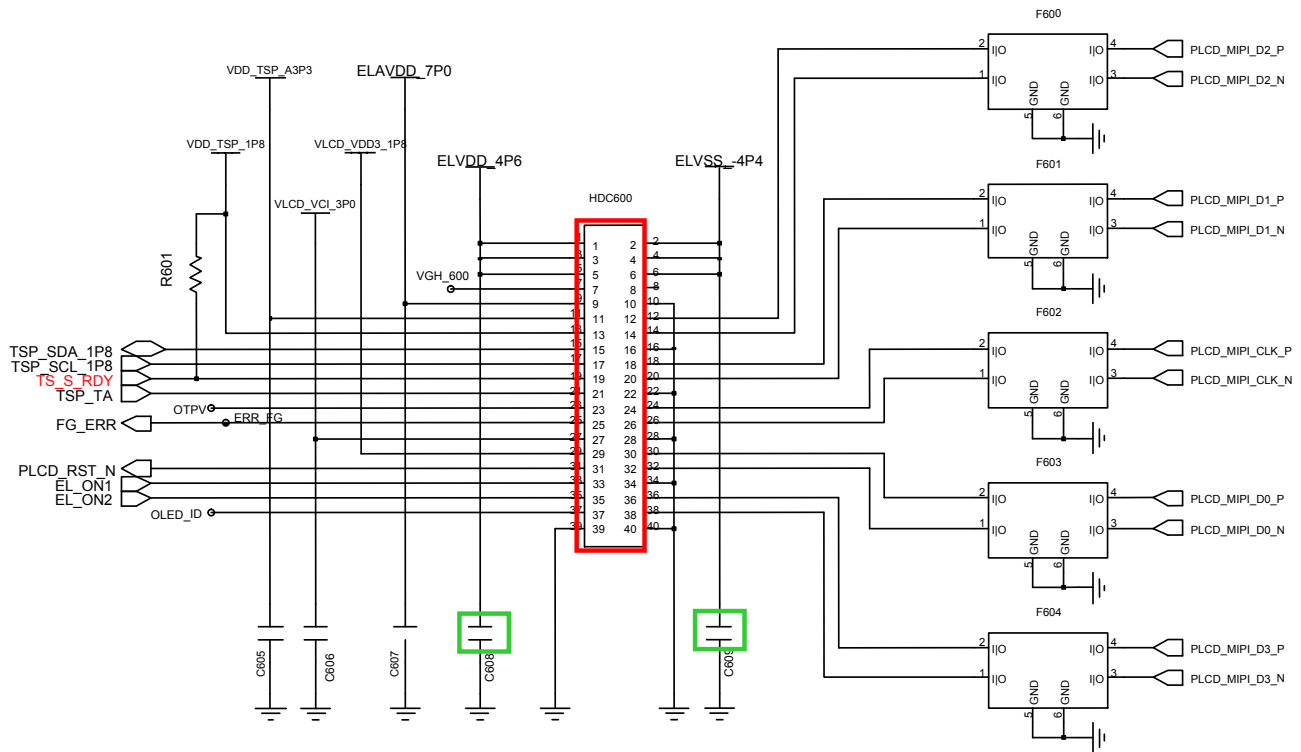

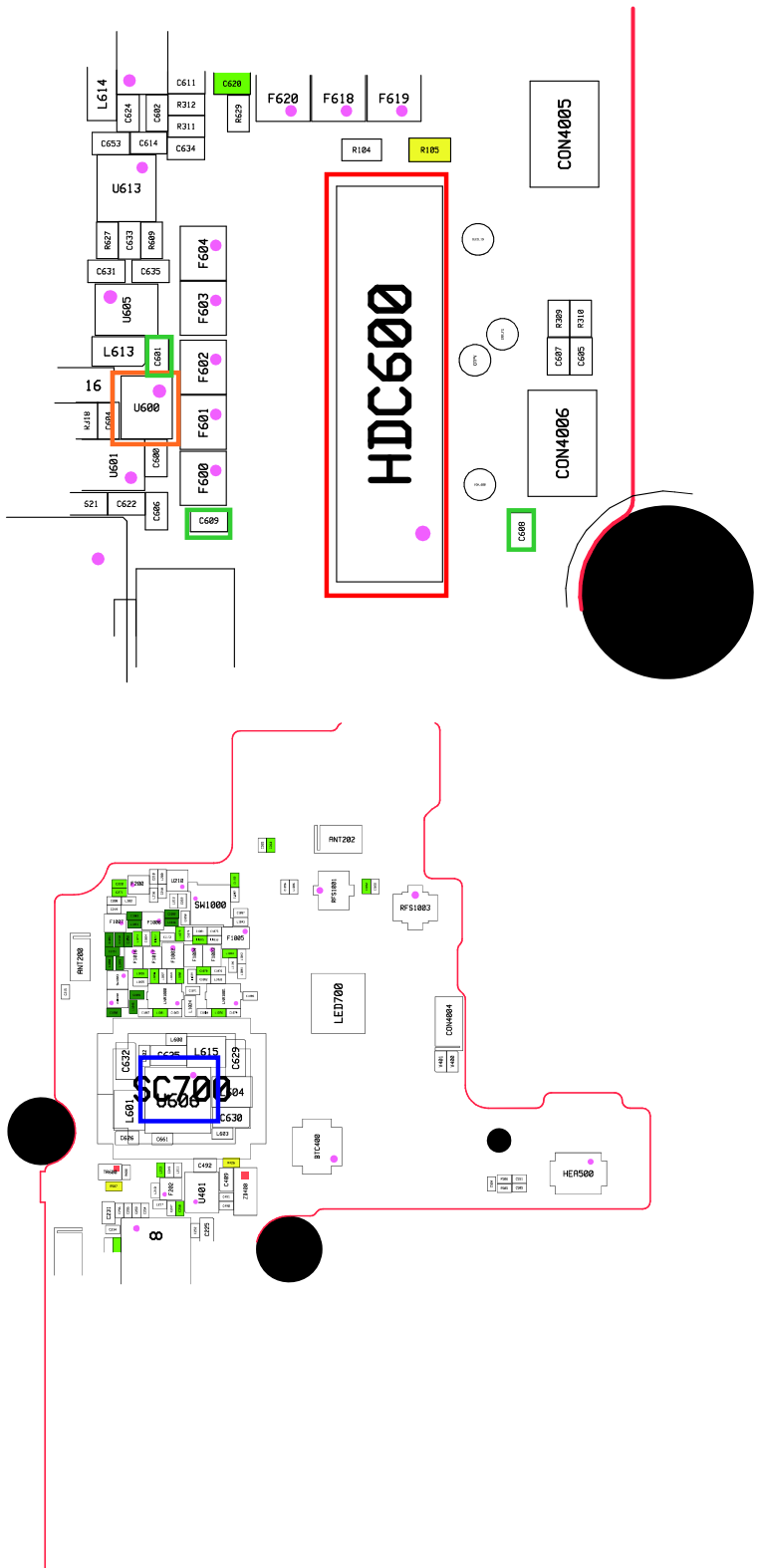

8-3-16. 13M CAM

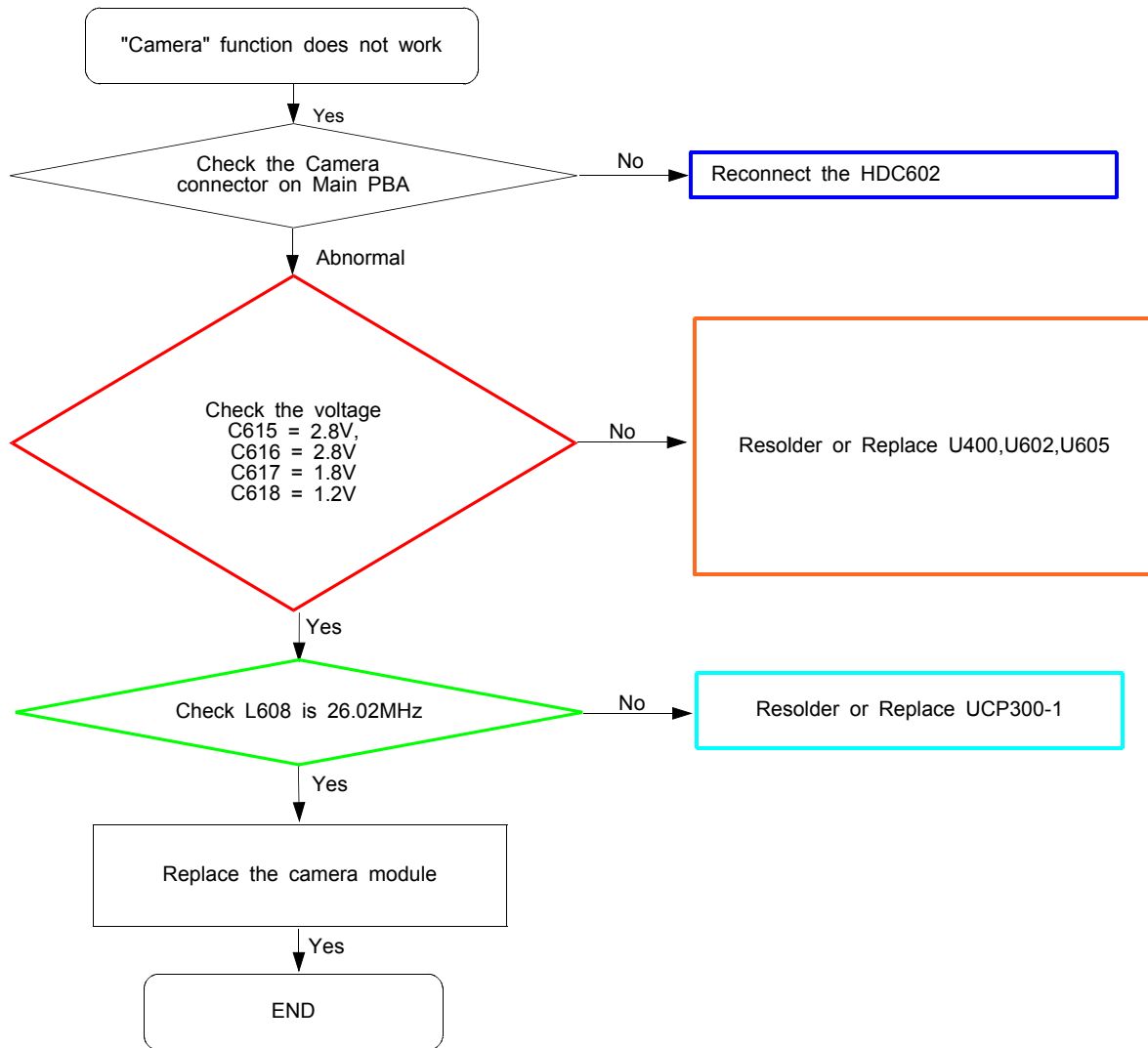

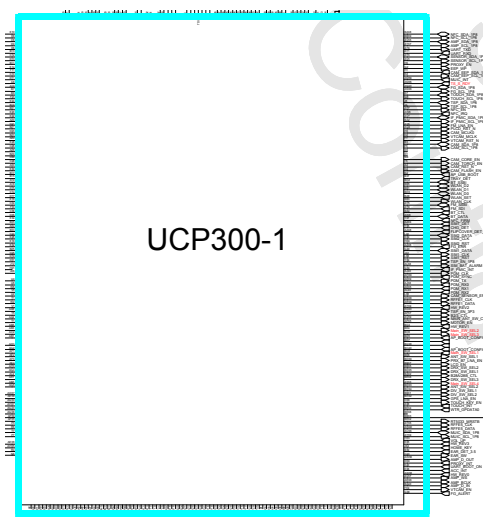
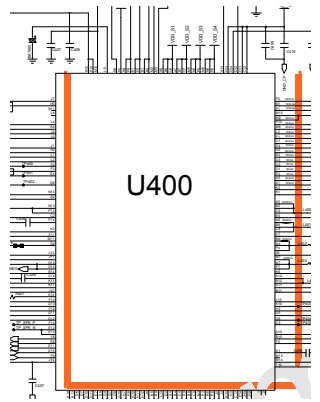
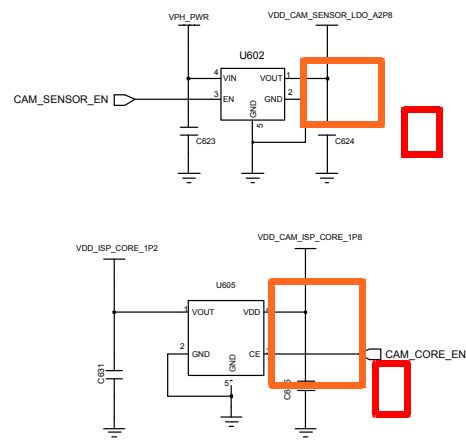
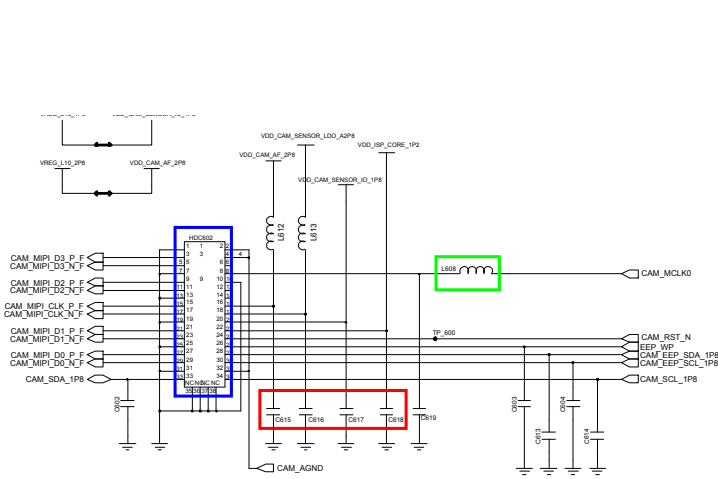

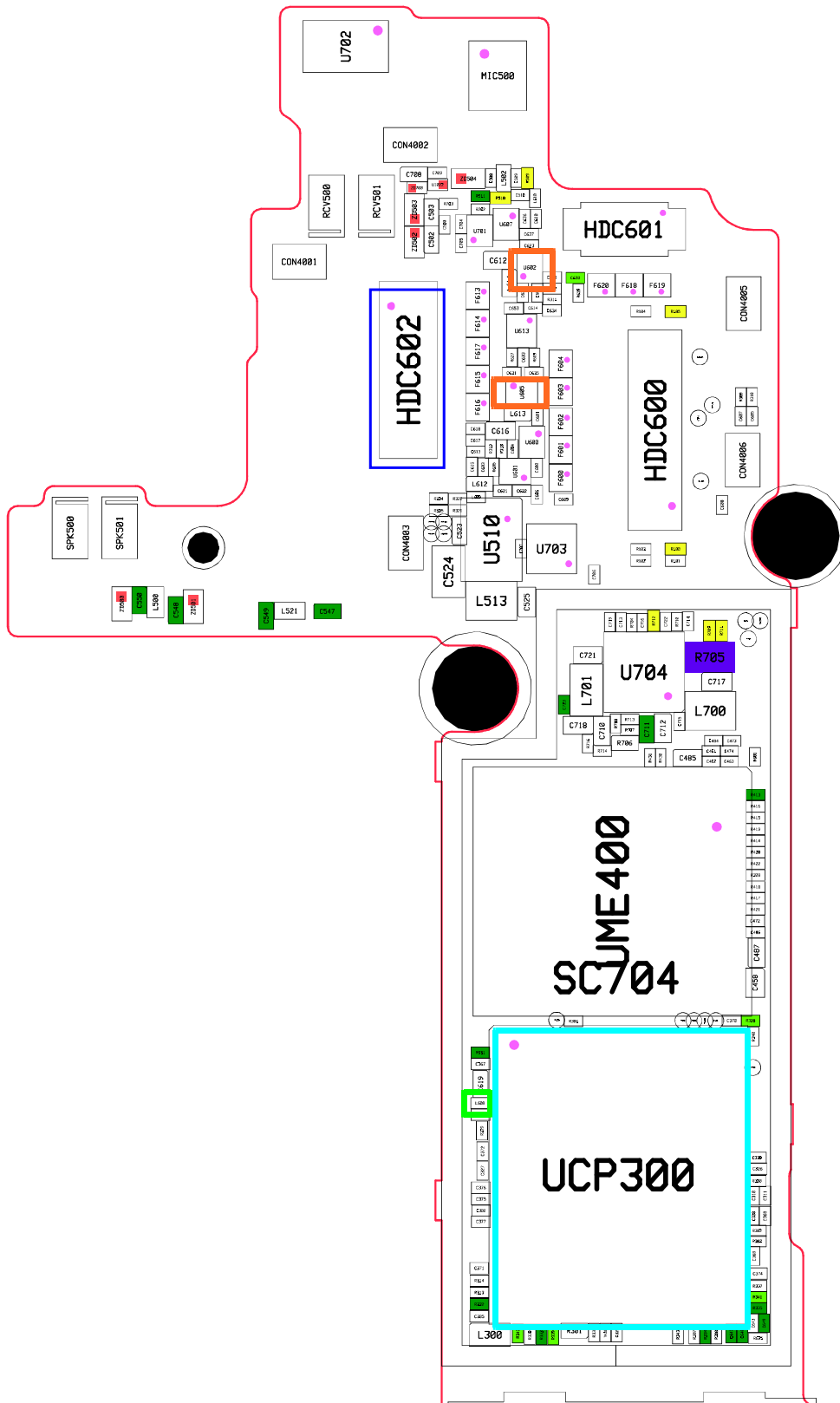

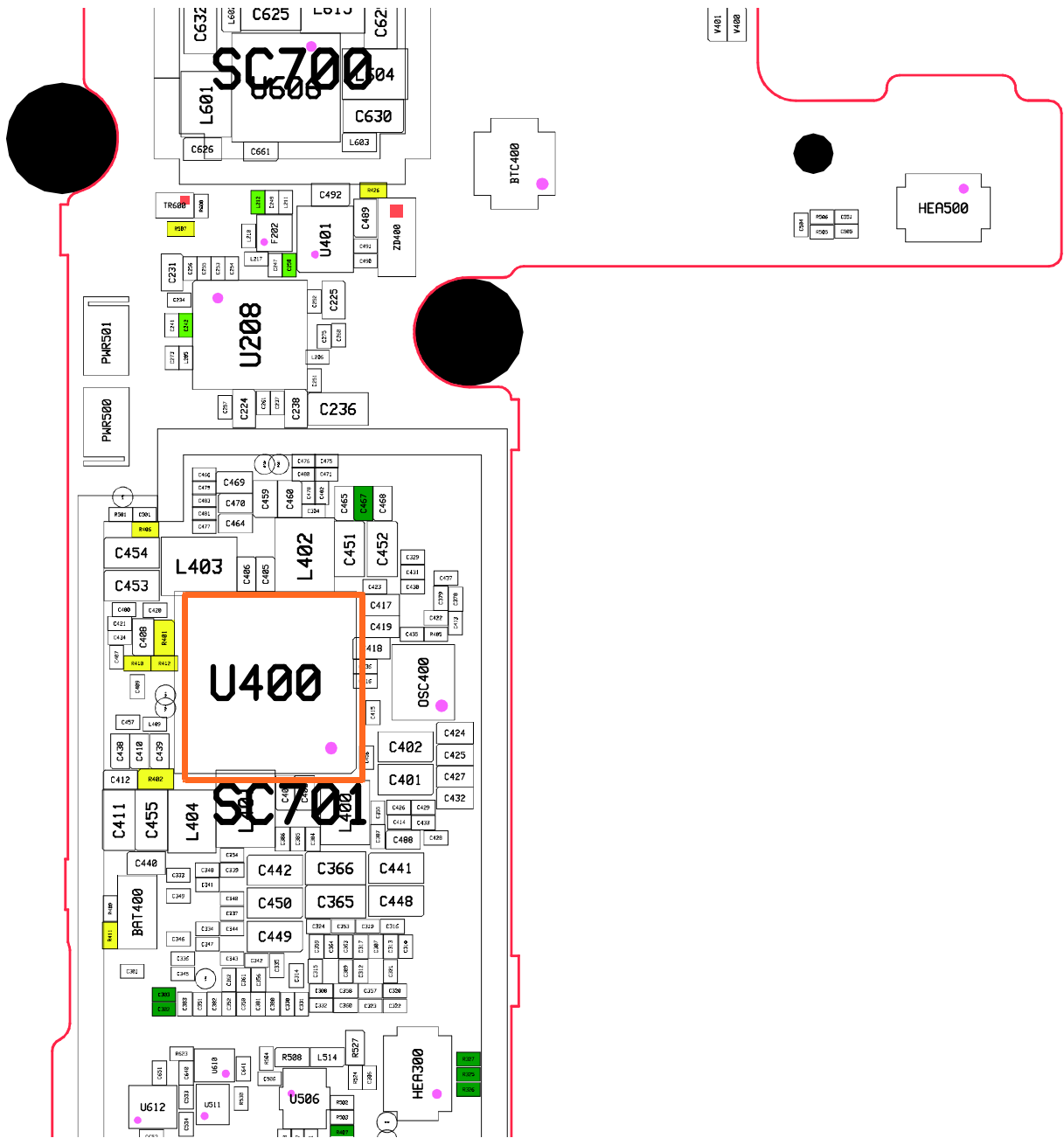

8-3-17. VT CAM

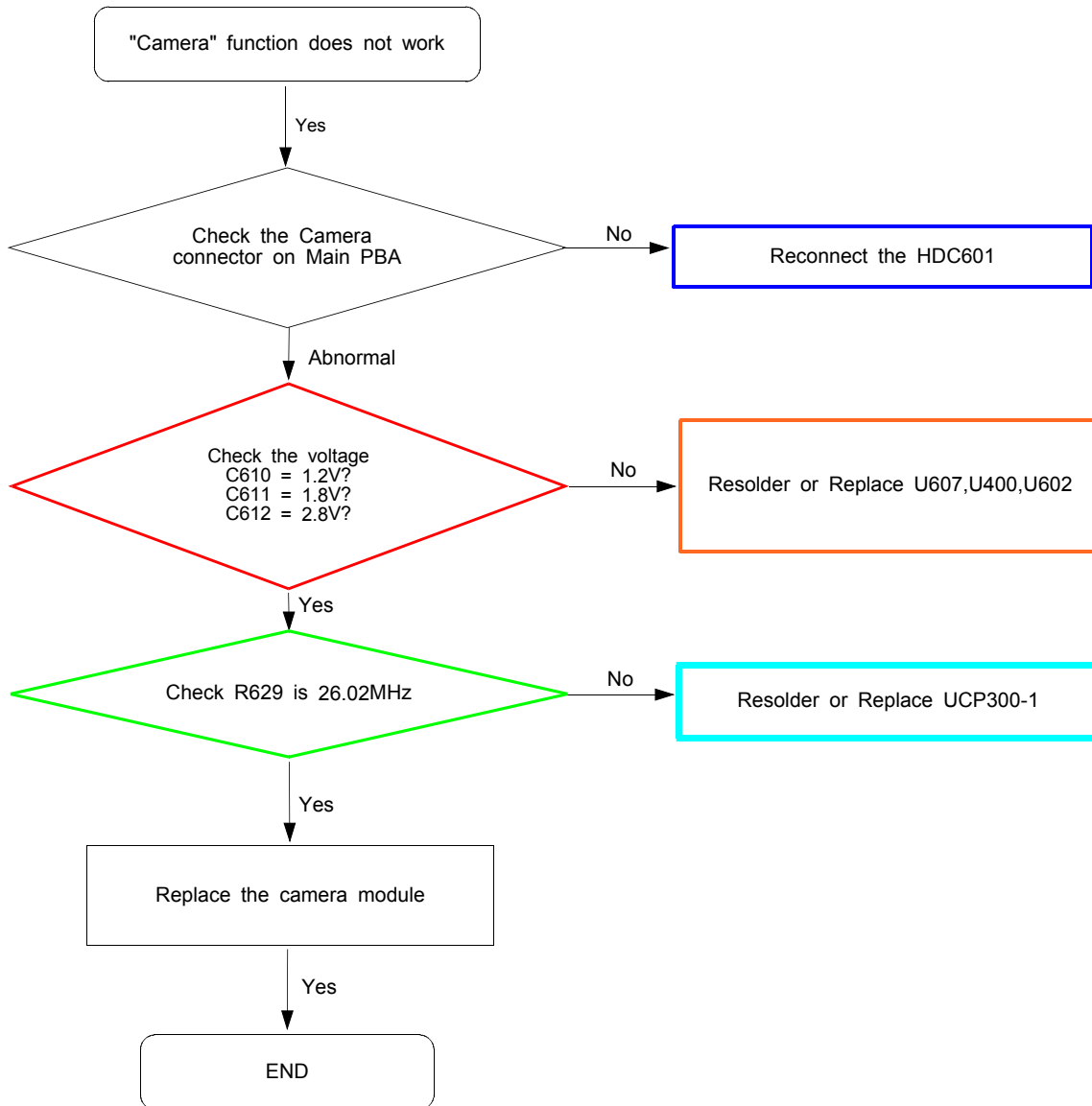

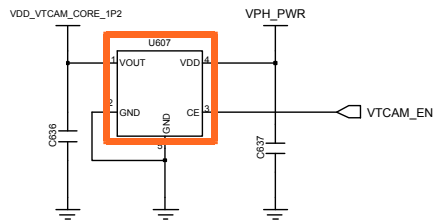
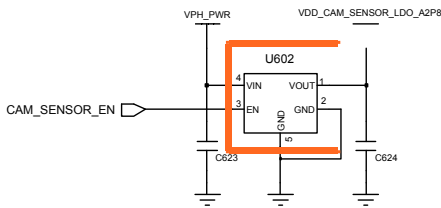
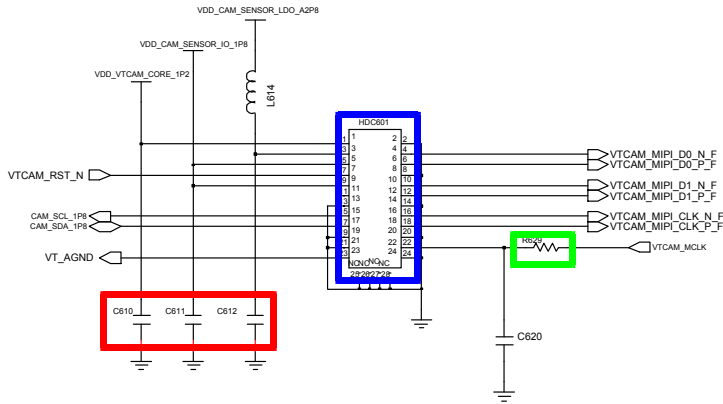

VT CAM LDO

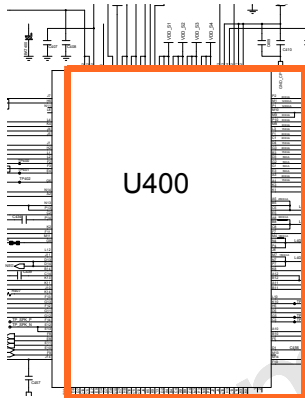

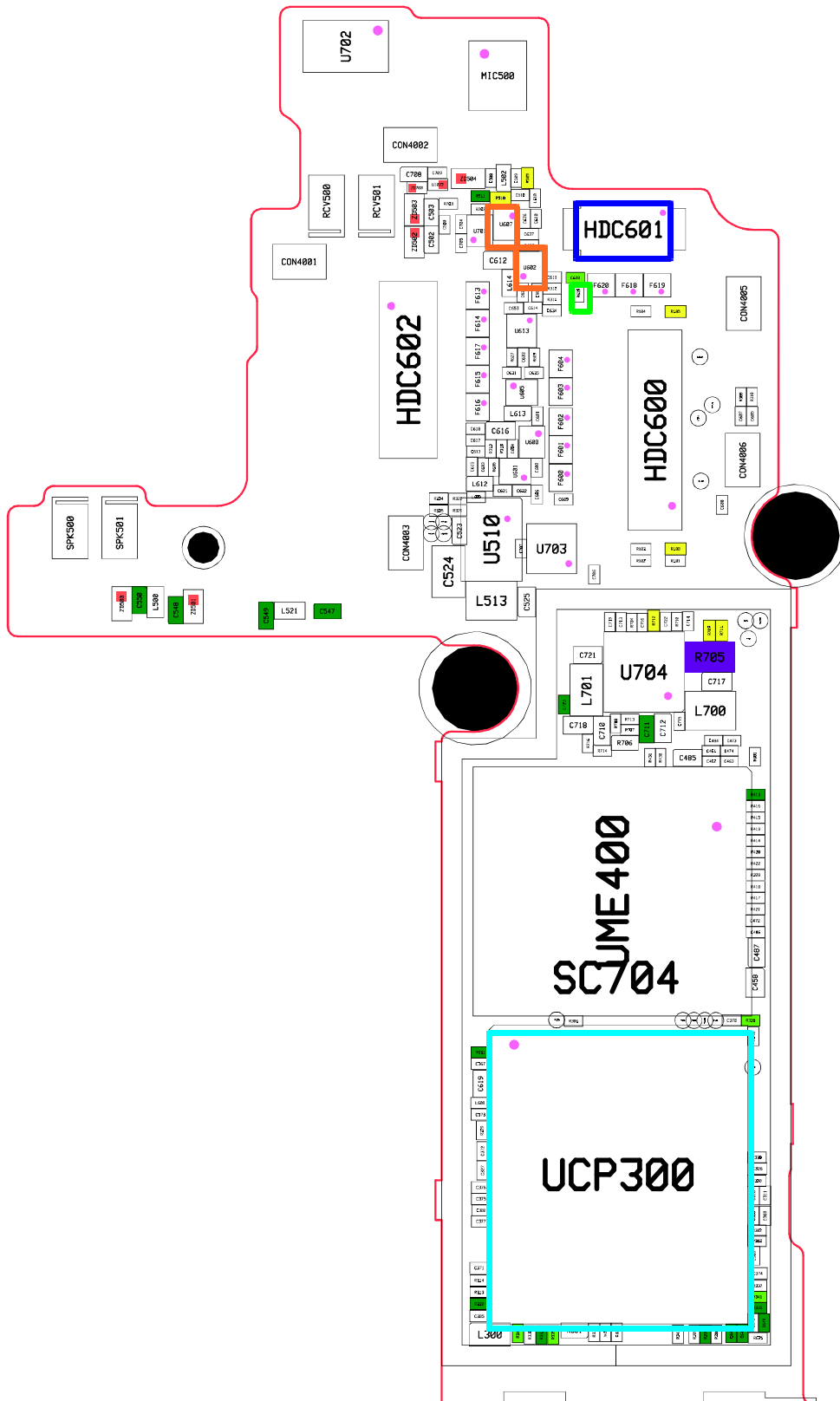

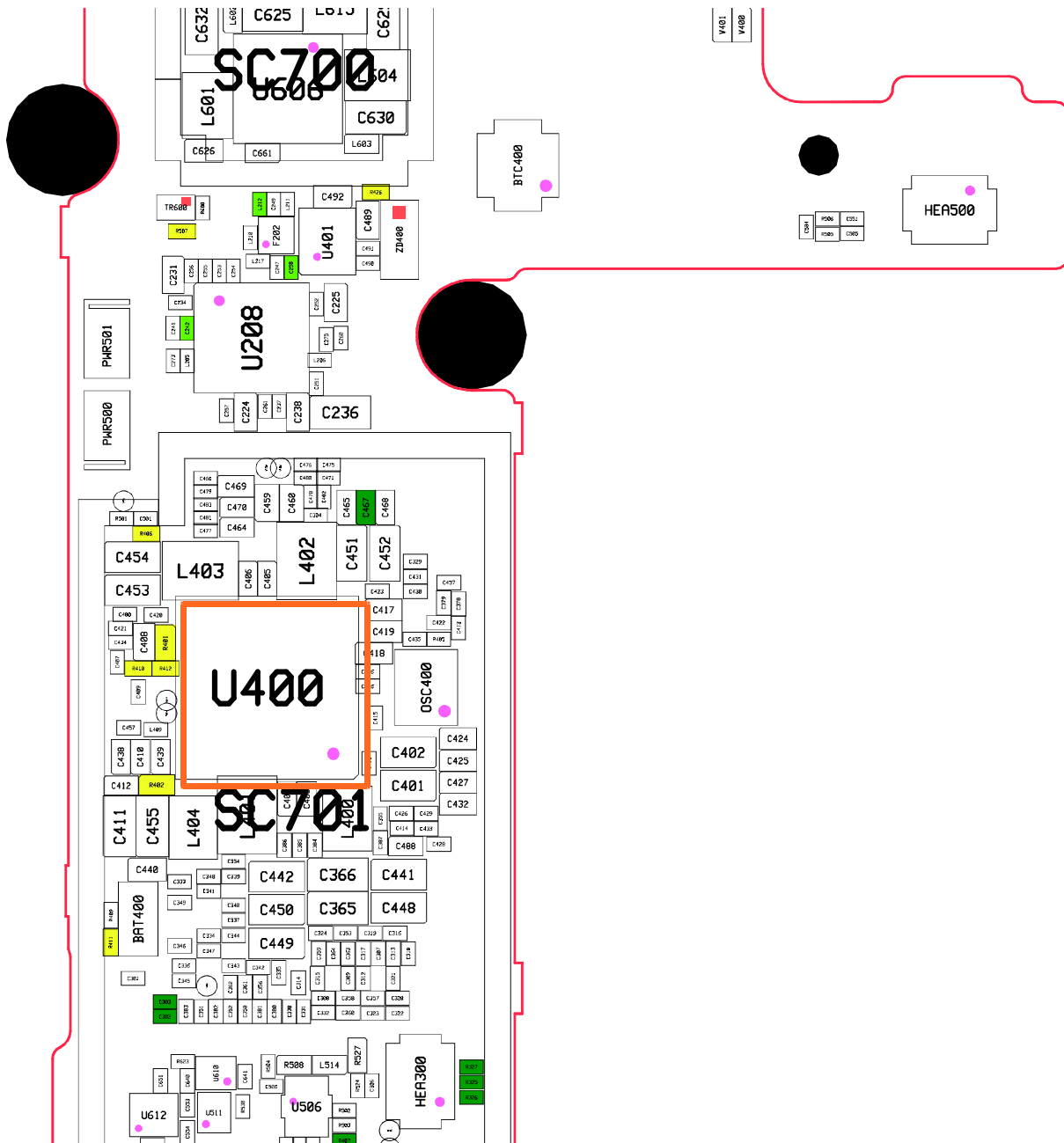

8-3-18. Ear Jack

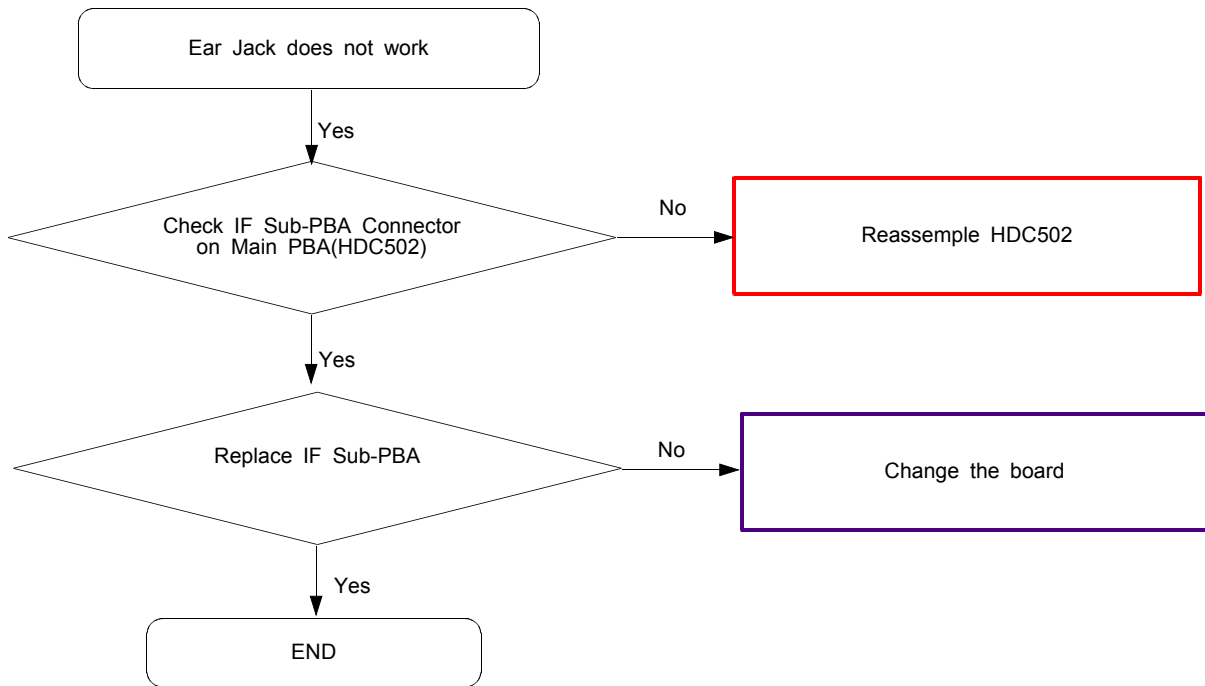

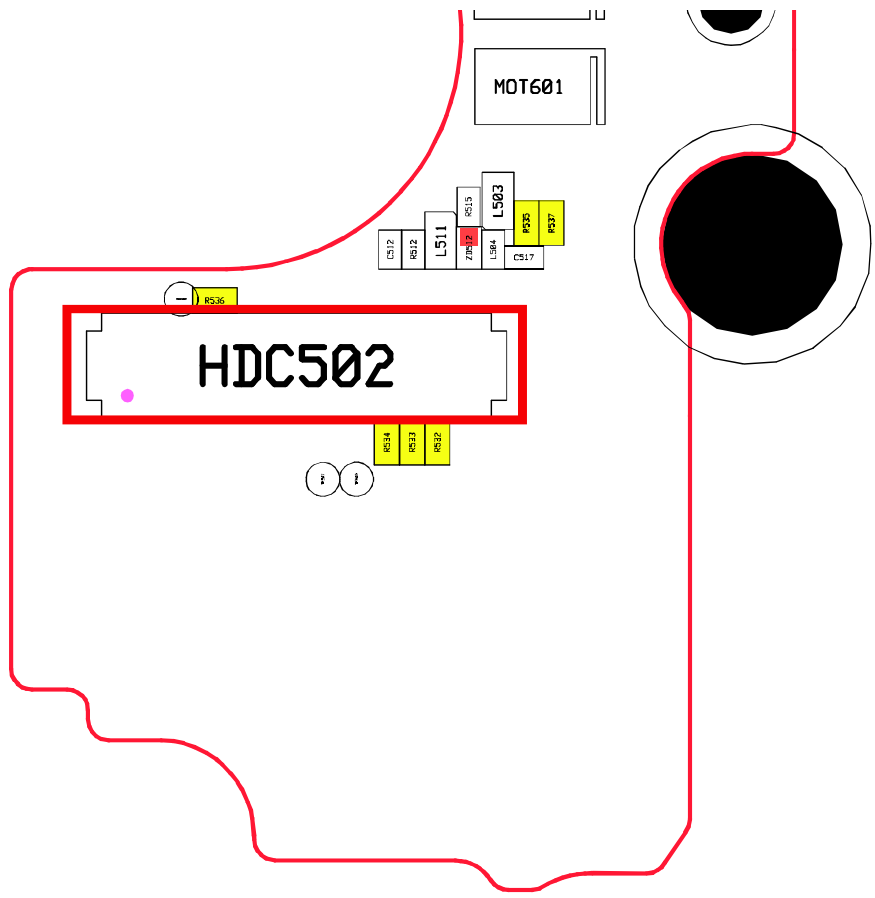
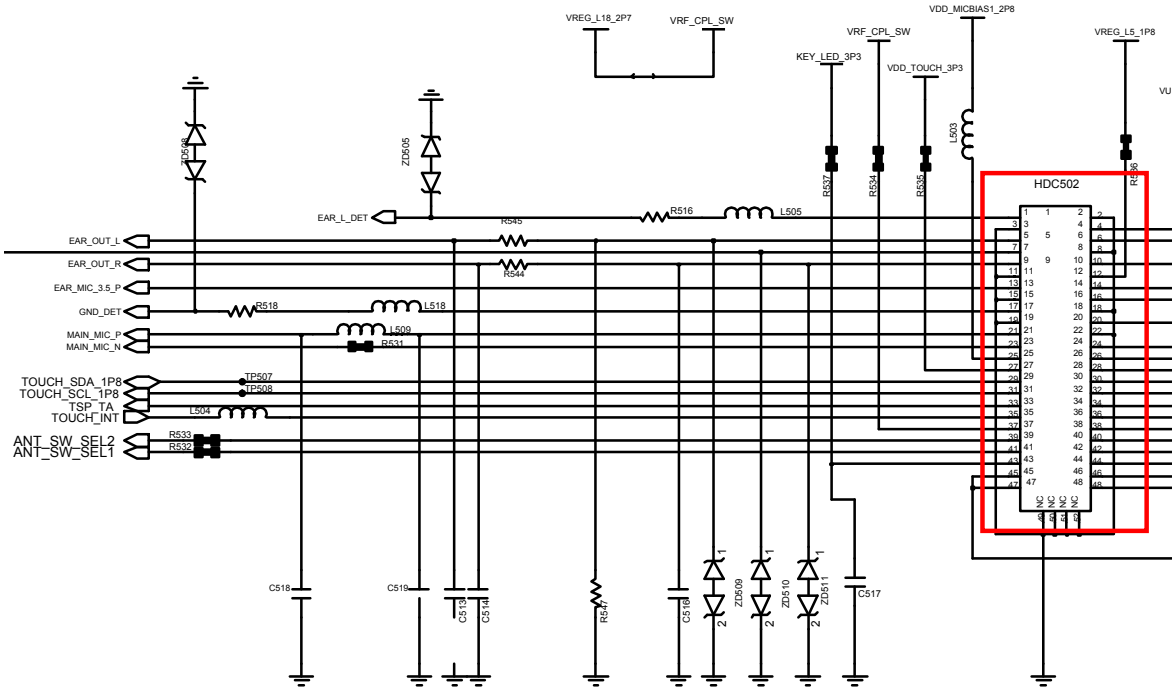

50107051 . 8-137

8-3-19. TSP

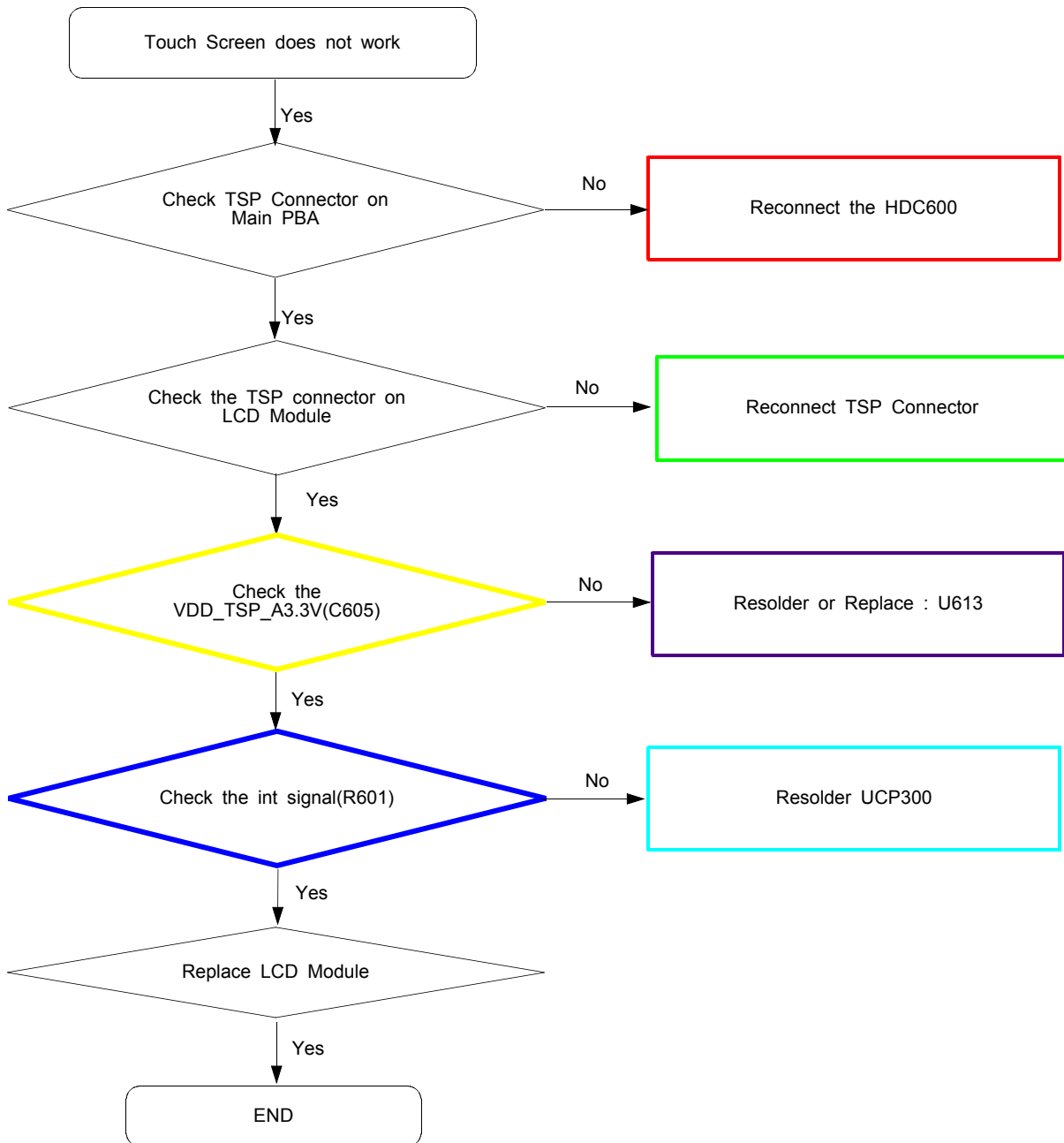

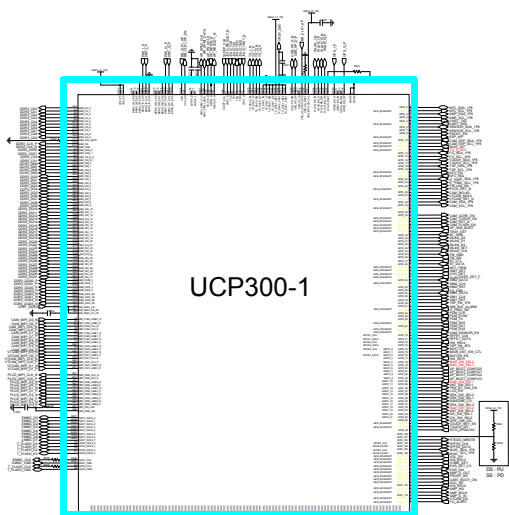
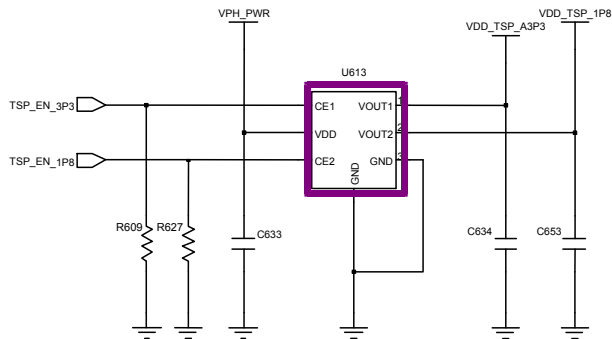
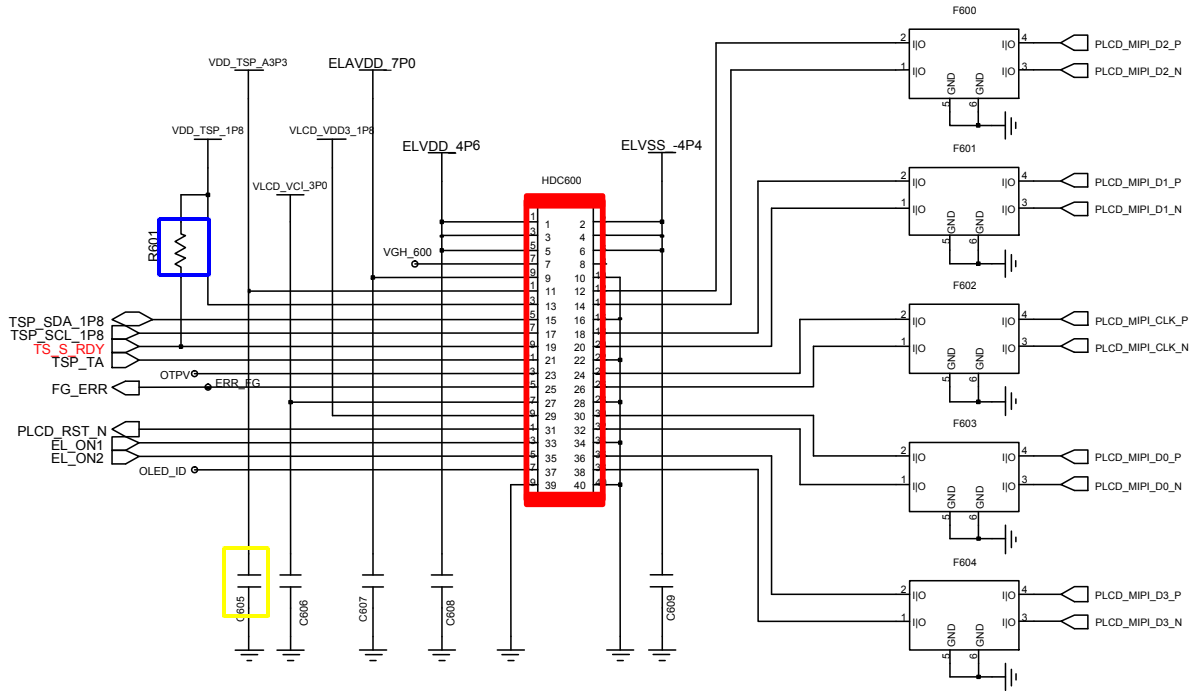

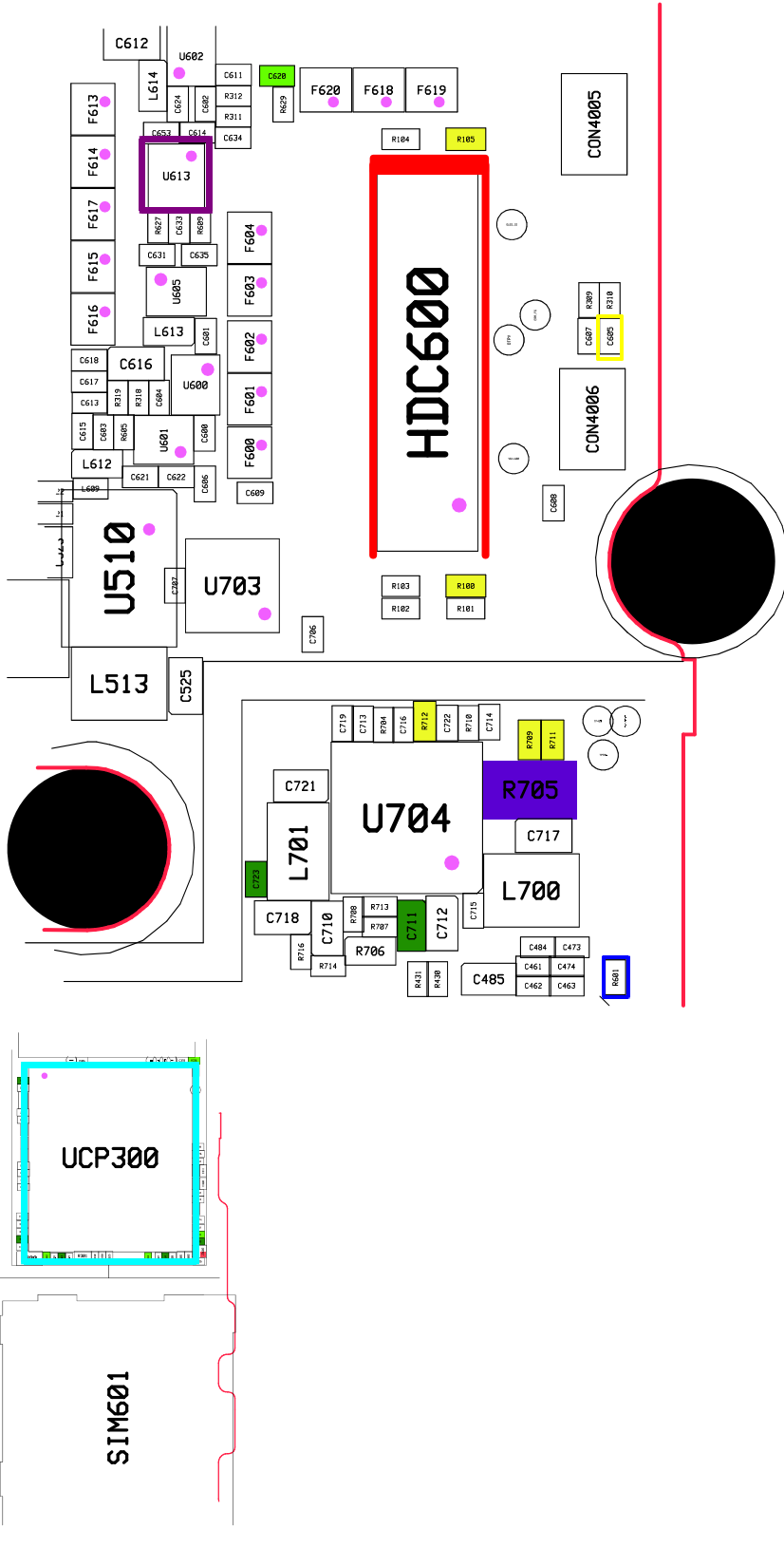

8-3-20. Motor

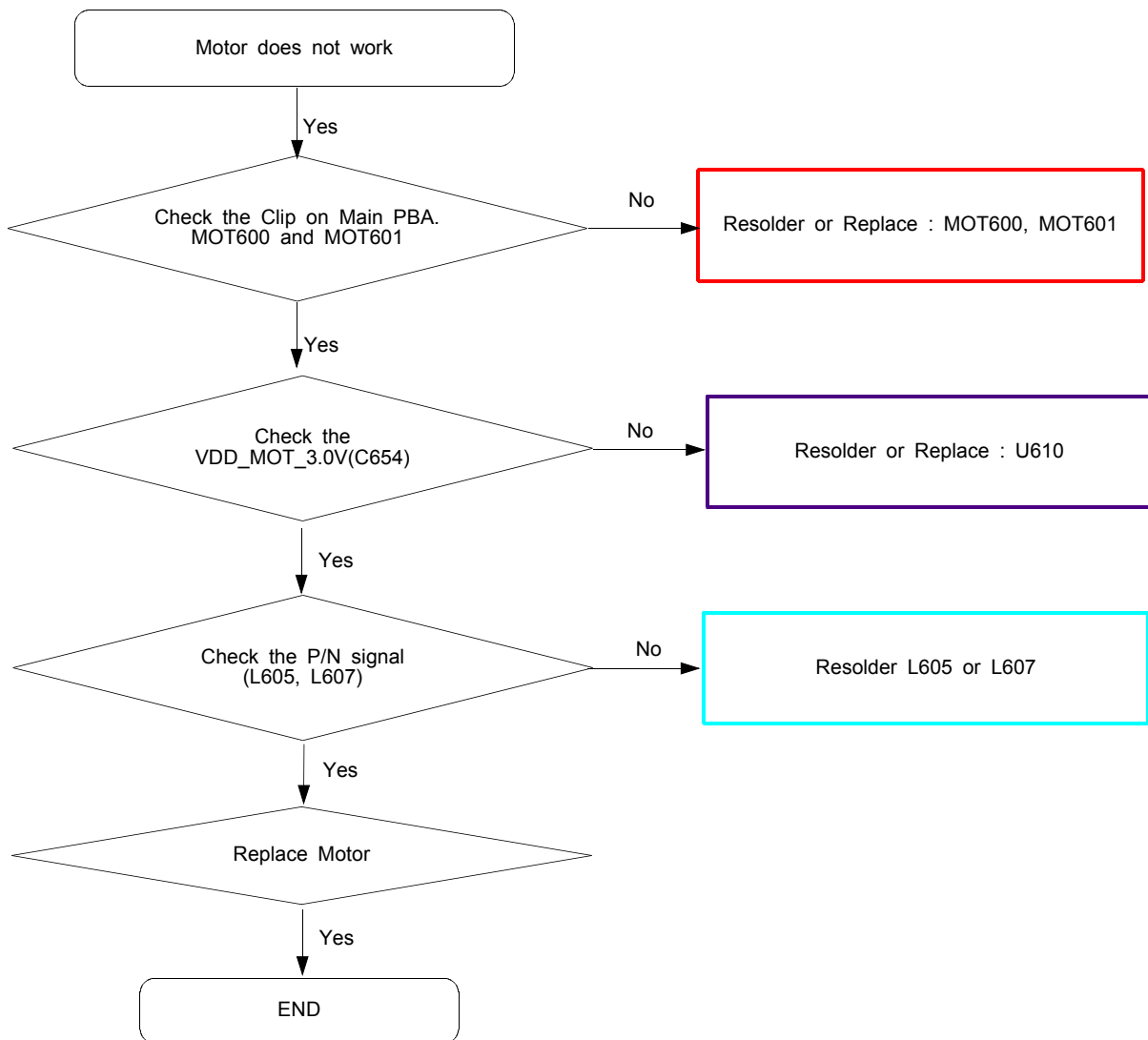

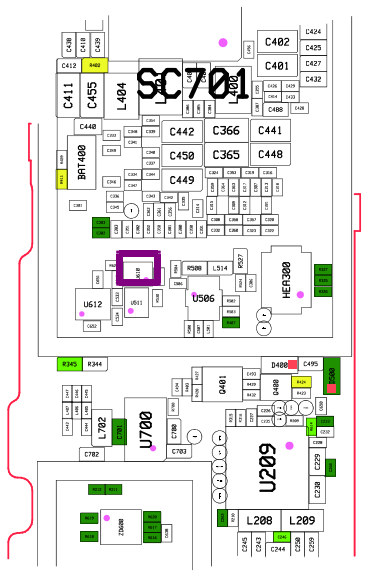
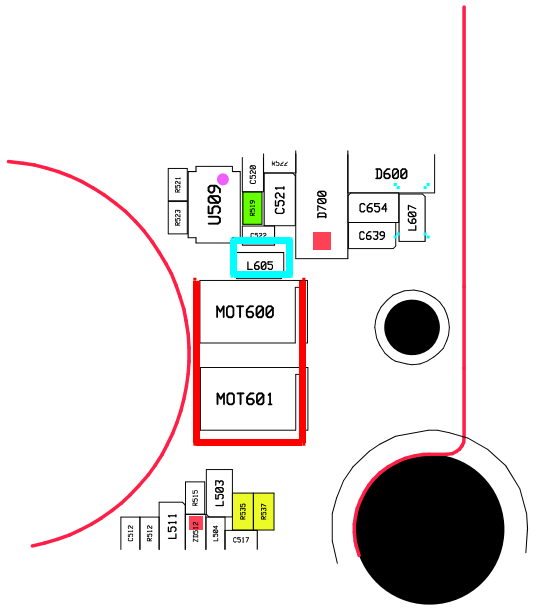
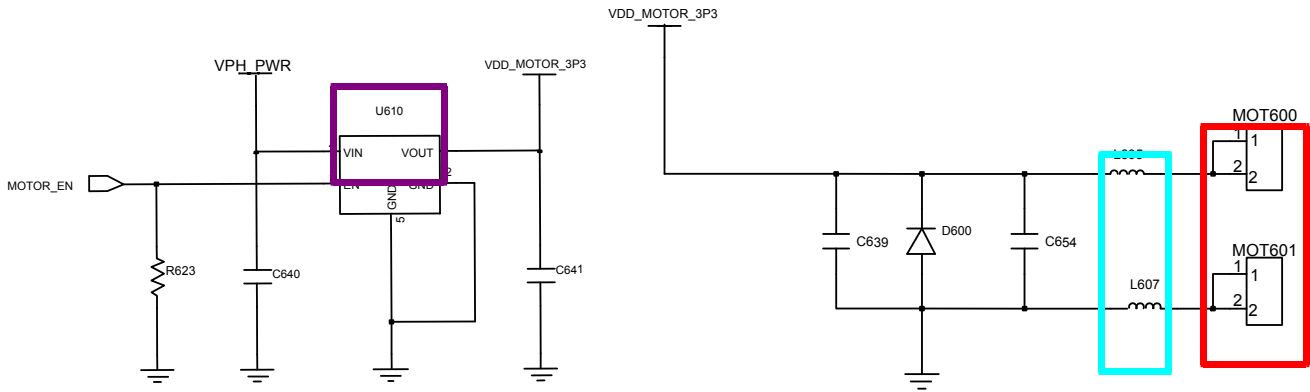

8-3-21. GSM850 / WCDMA B5 / LTE5 RX

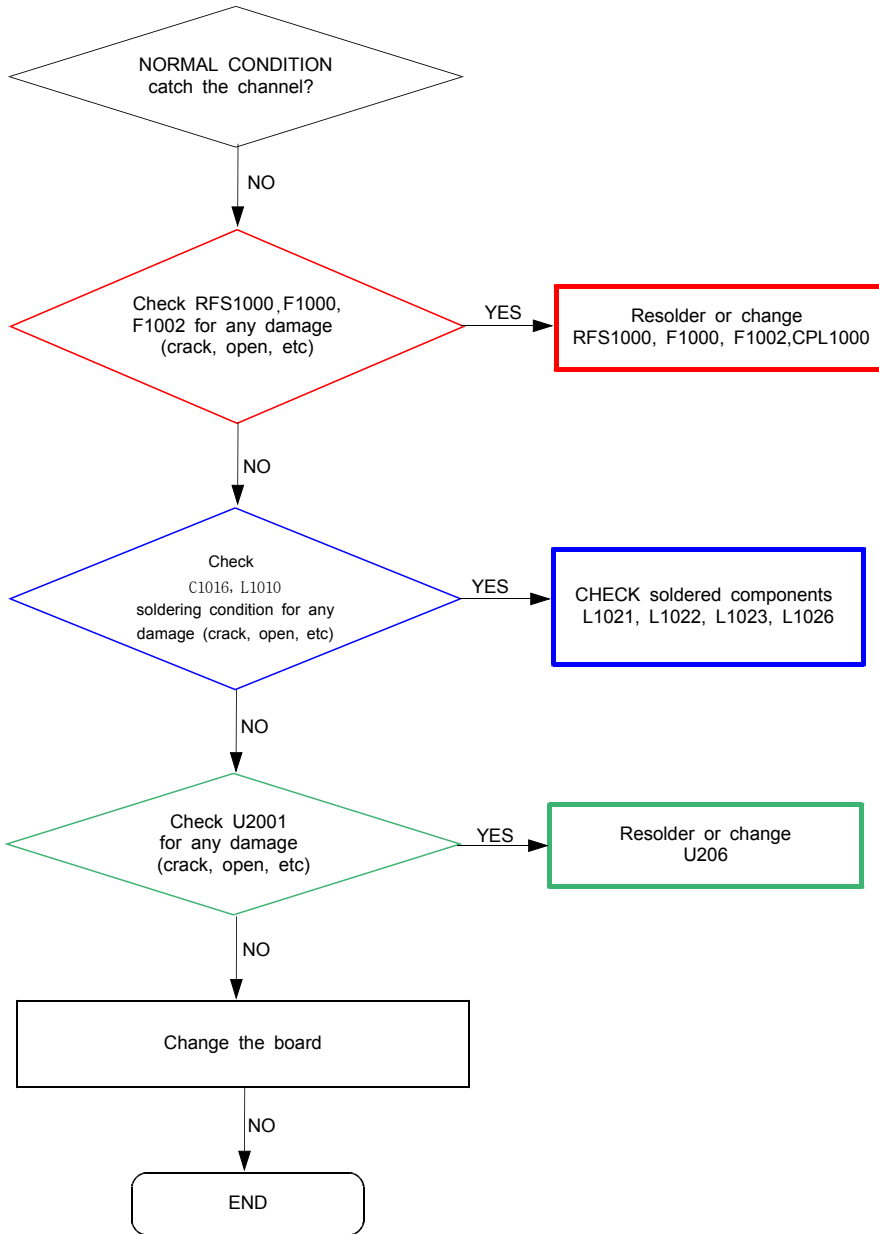

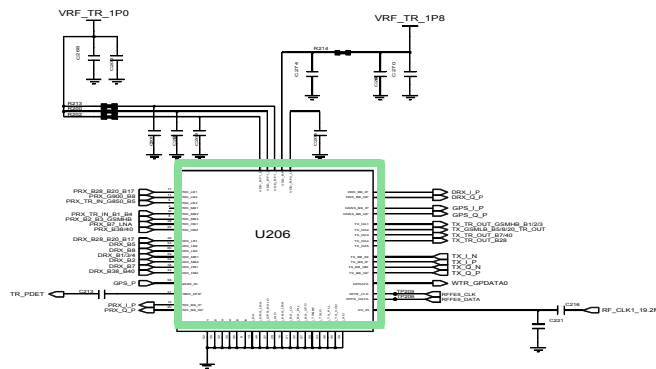
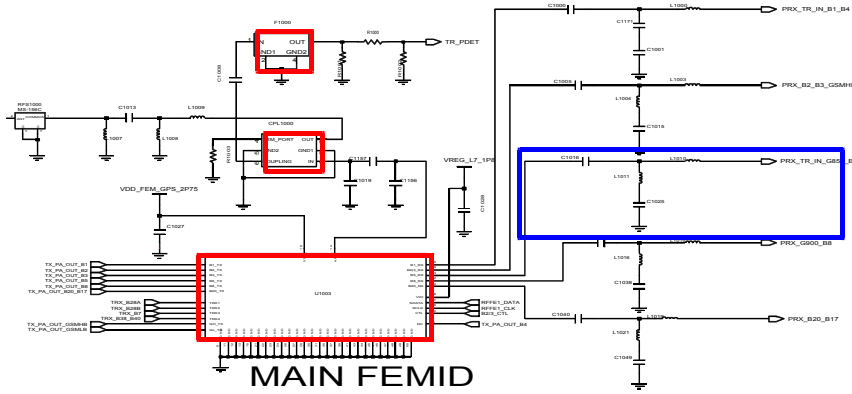

RF Transceiver



8-3-22. GSM900 / WCDMA B8 / LTE8 RX

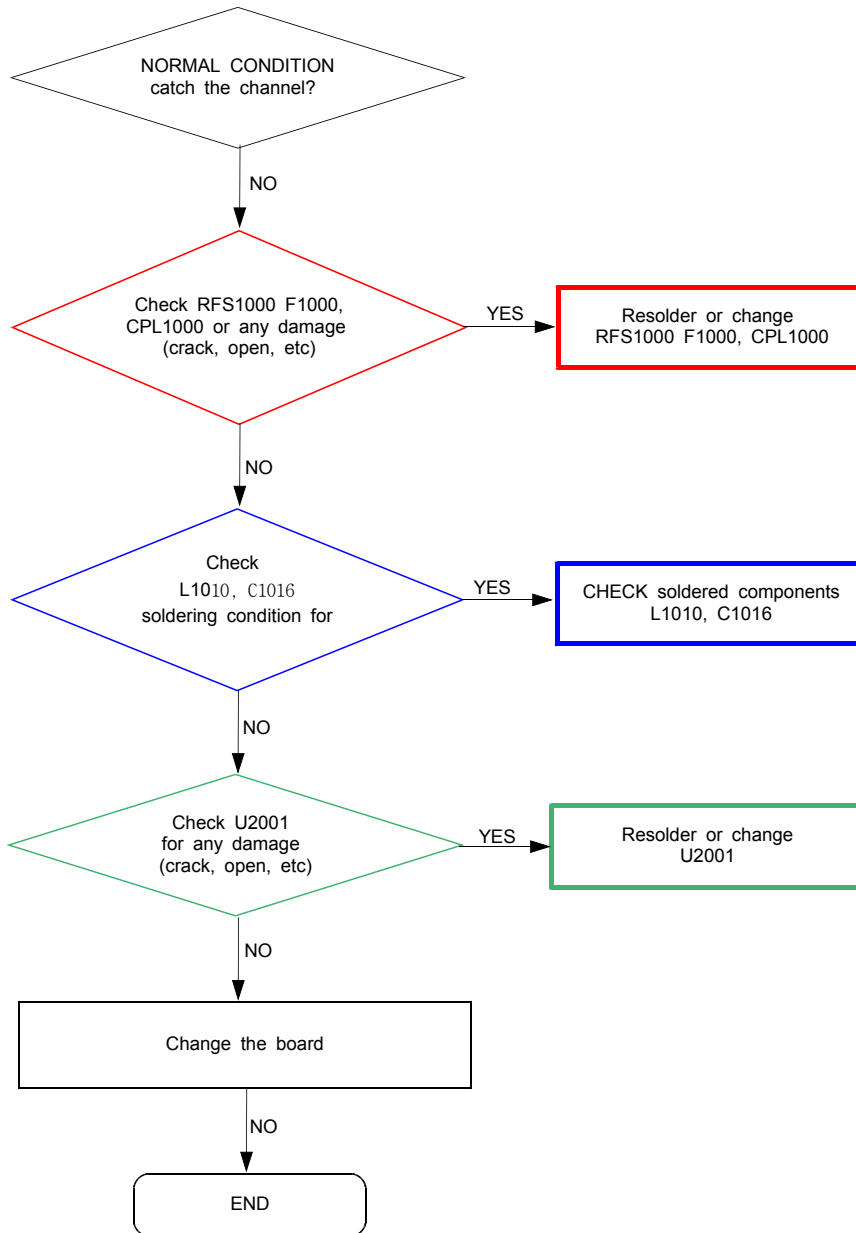

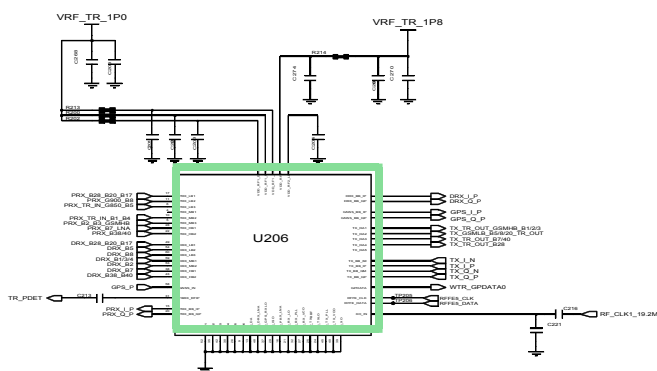
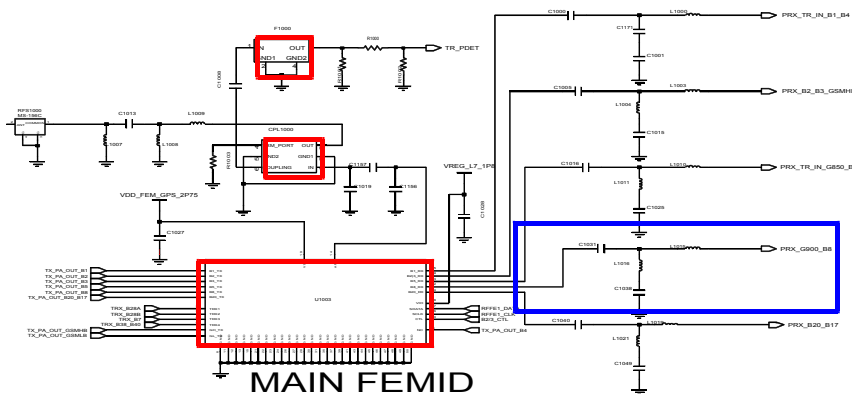

RF Transceiver



8-3-23. GSM1800 / GSM1900 B2 / B3 RX

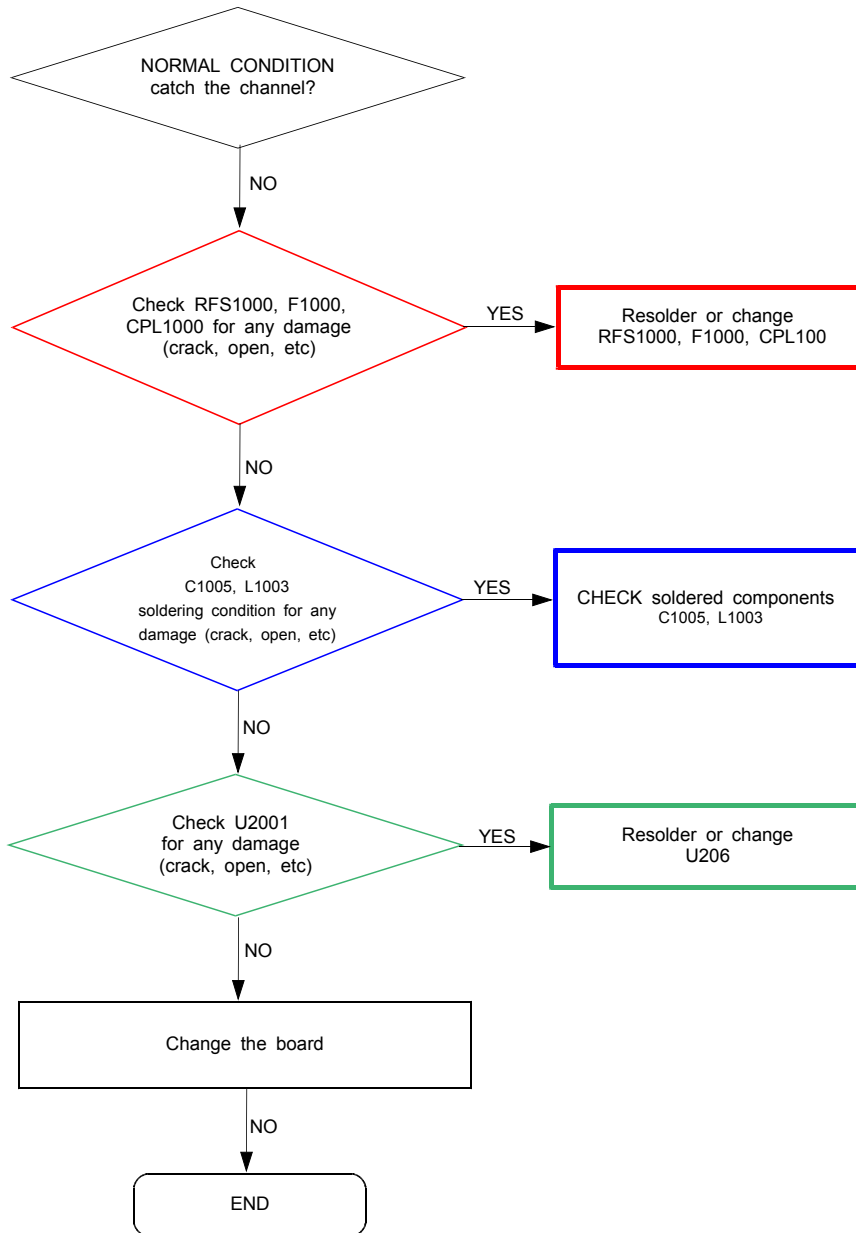

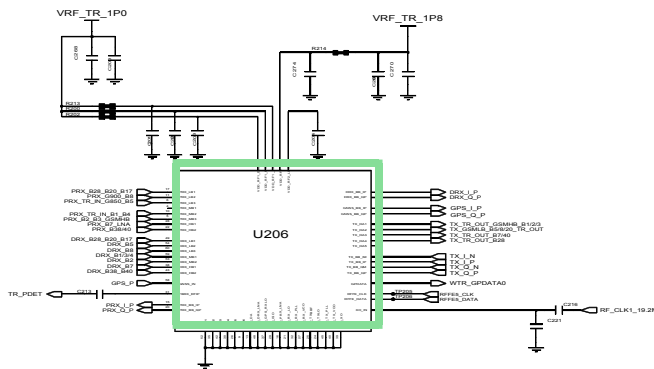
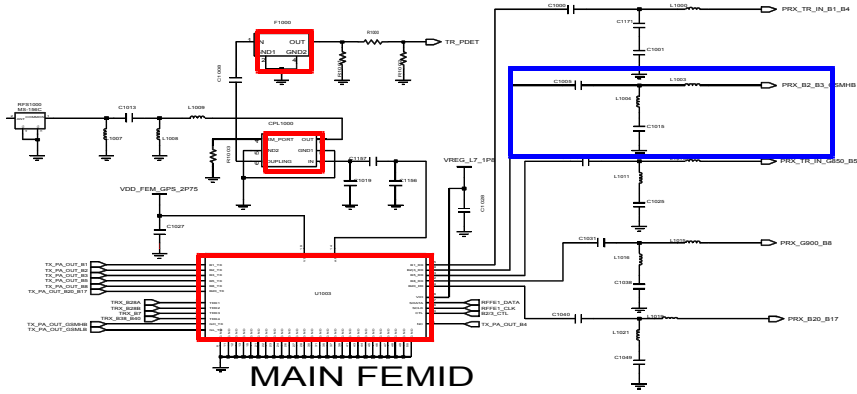

RF Transceiver



8-3-24. WCDMA B1 / LTE1 RX

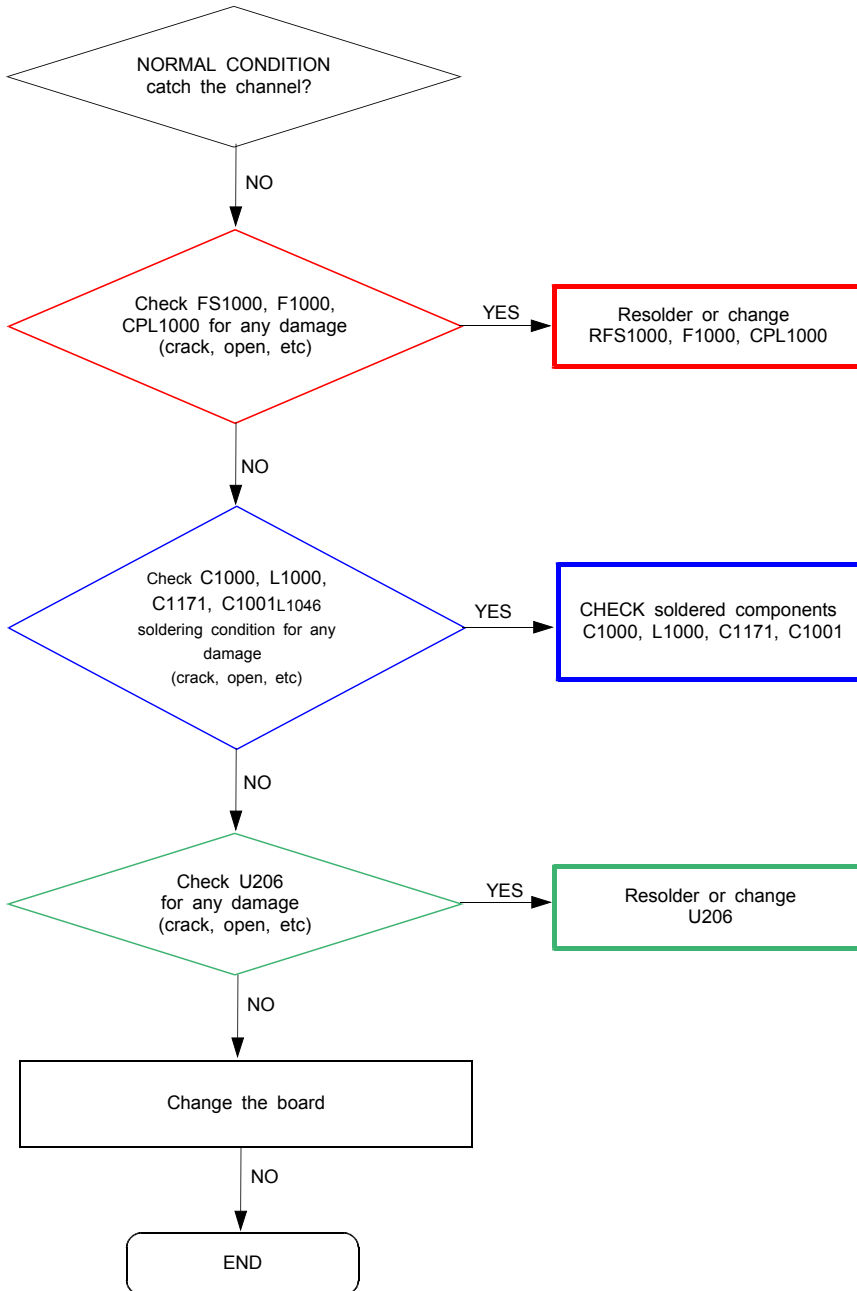

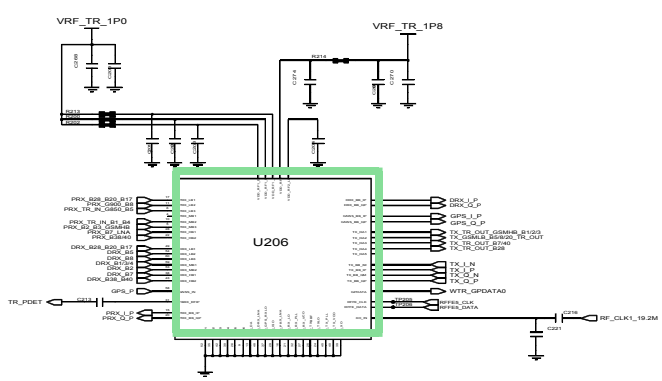
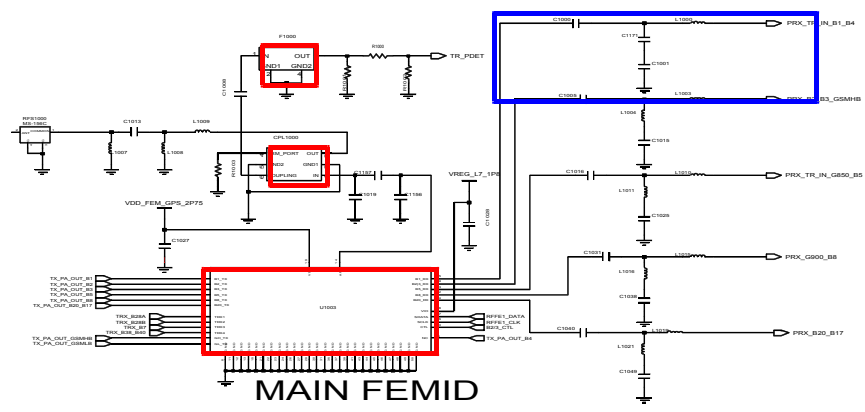

RF Transceiver



8-3-25. LTE7 RX

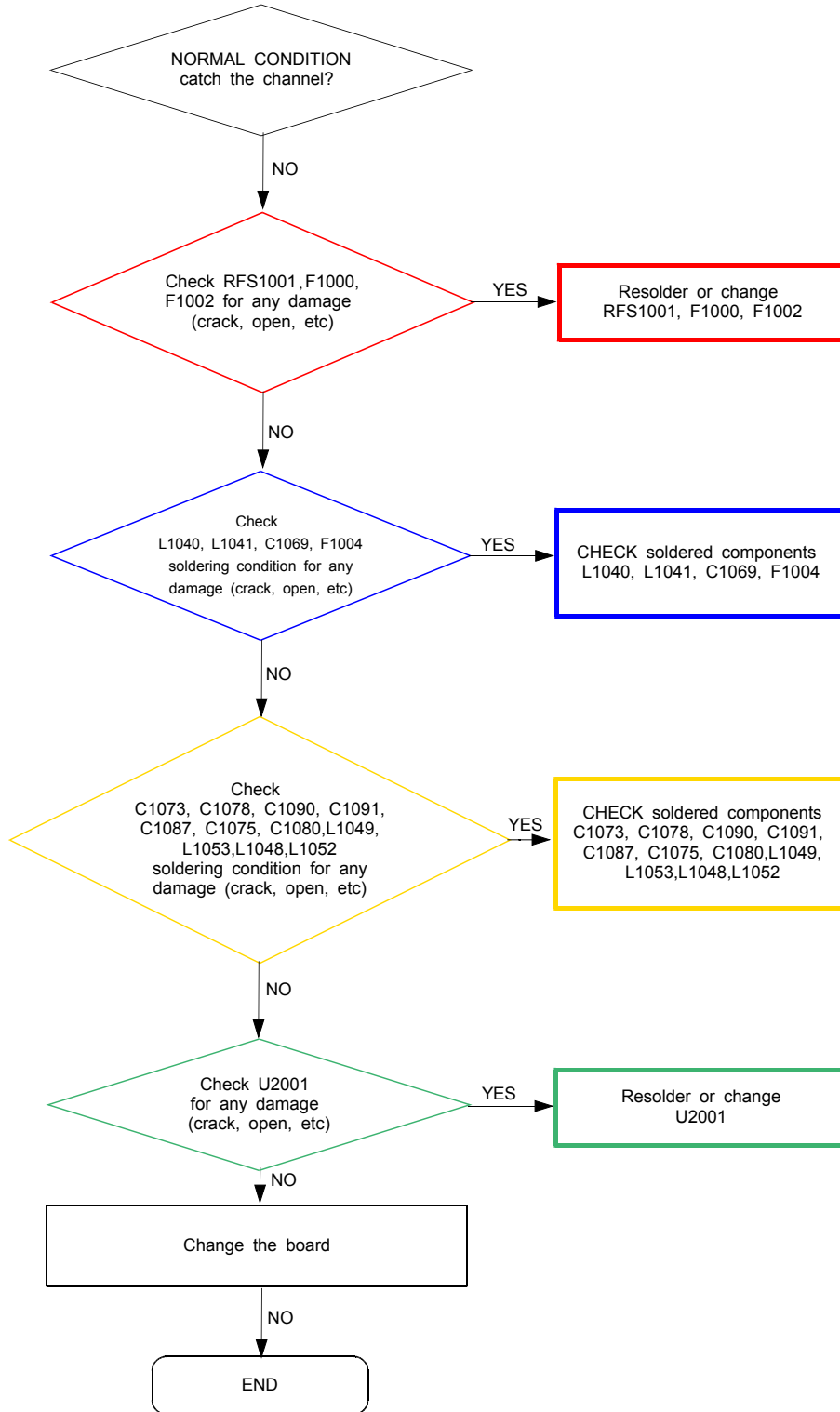

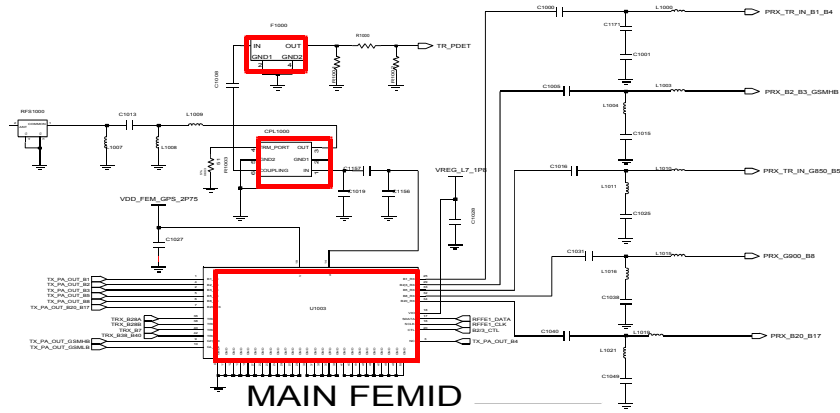

MAIN FEMID

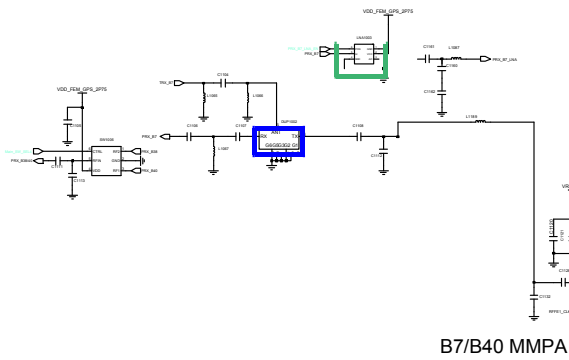

B7/B40 MMPA

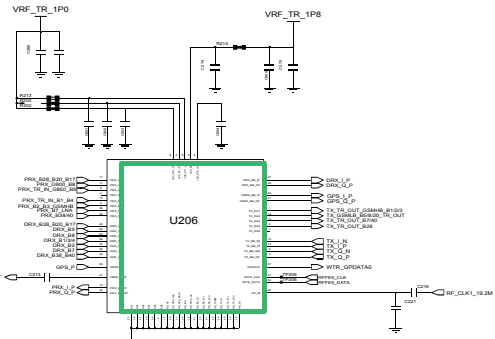

RF Transceiver



8-3-26. LTE20 RX

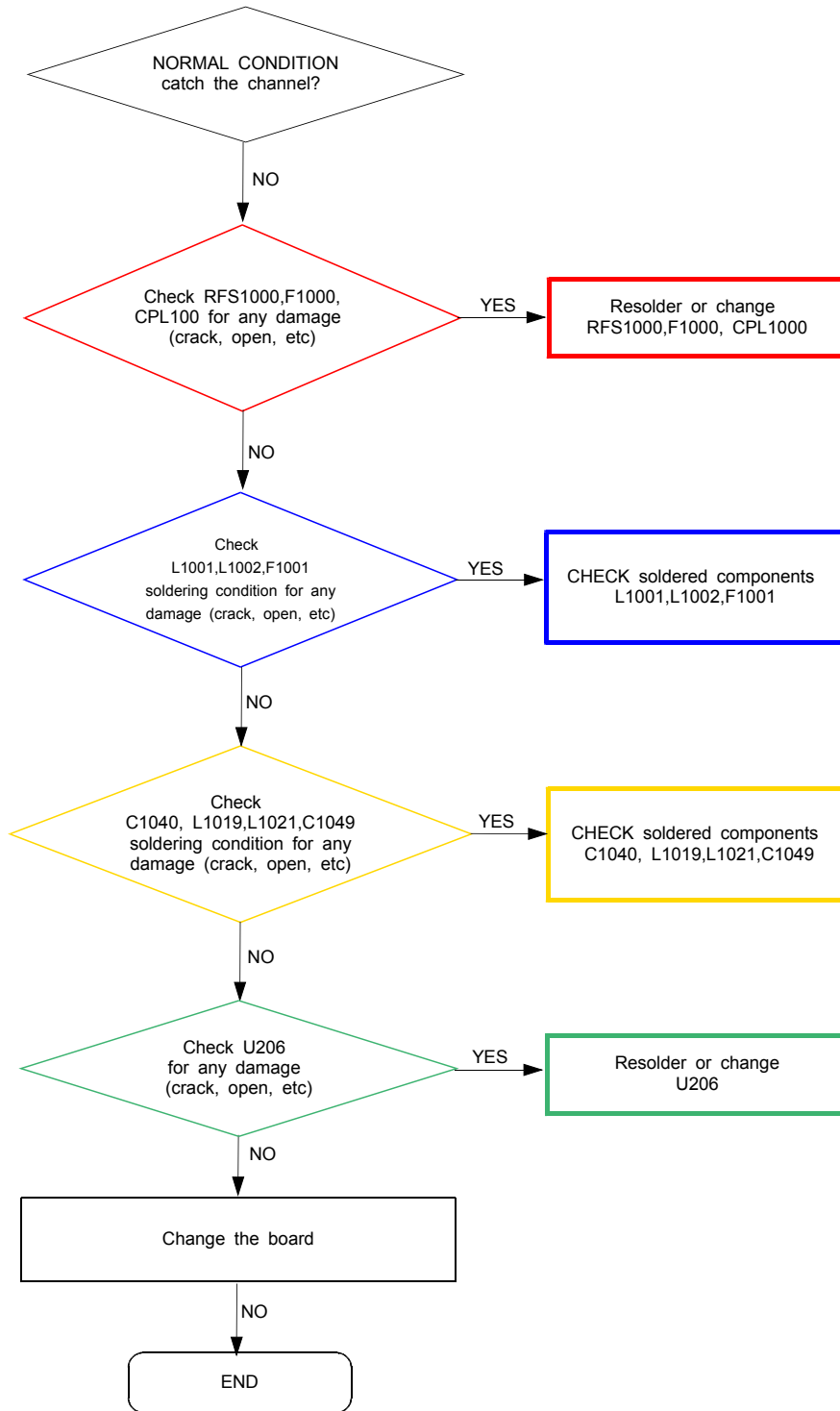

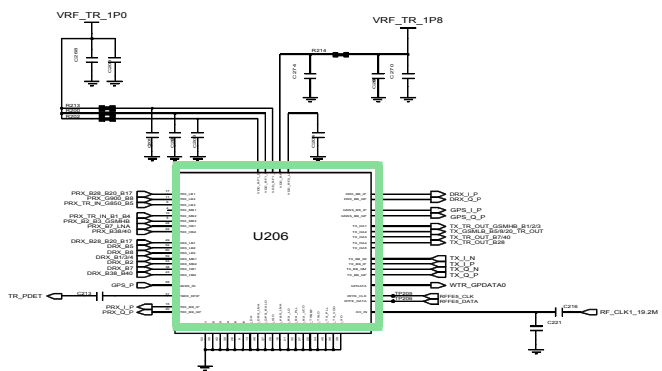
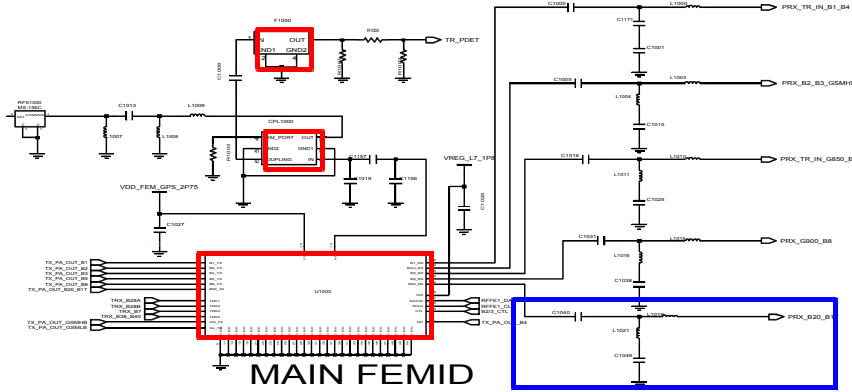

RF Transceiver



8-3-27. GSM850 / GSM900 TX

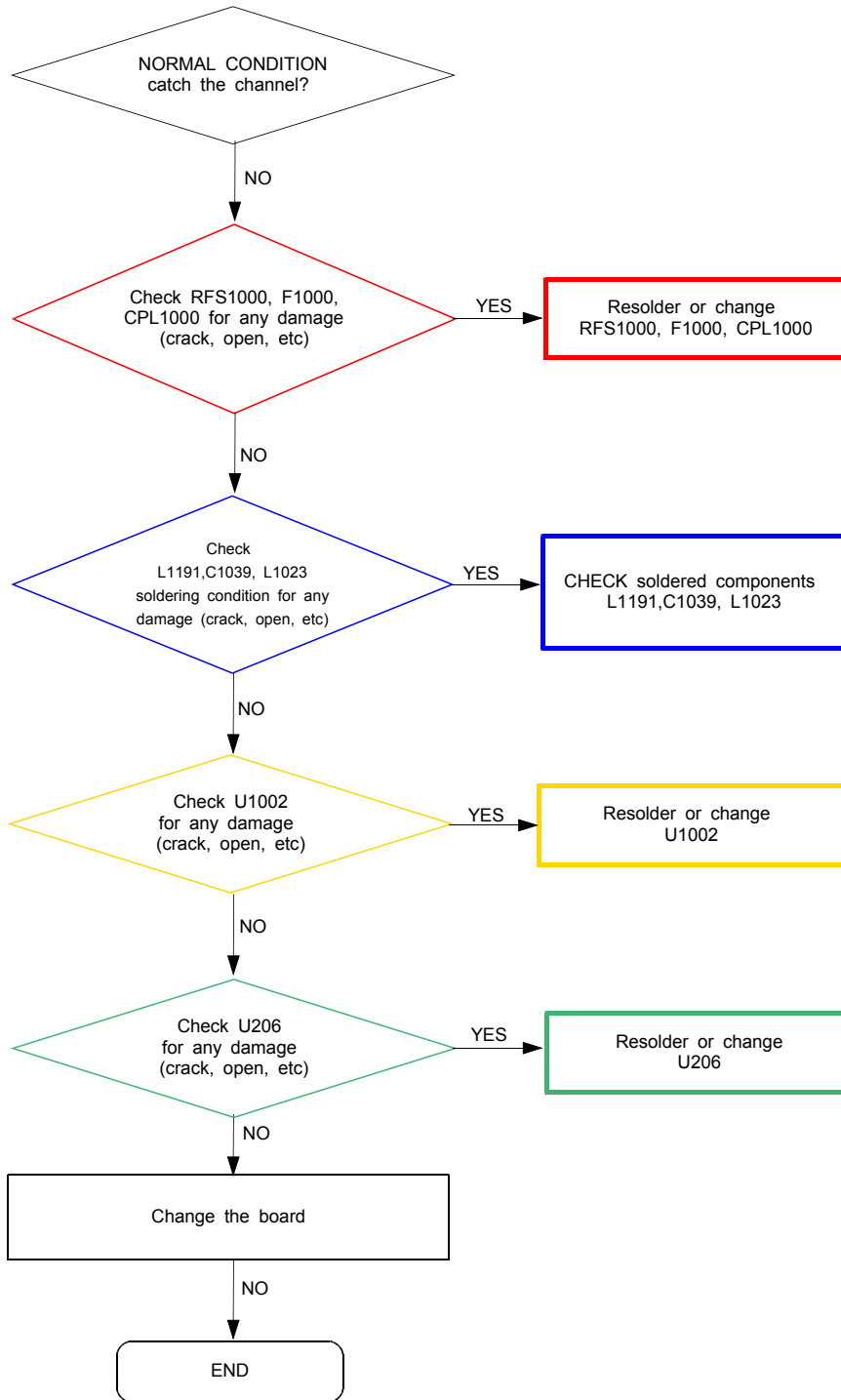

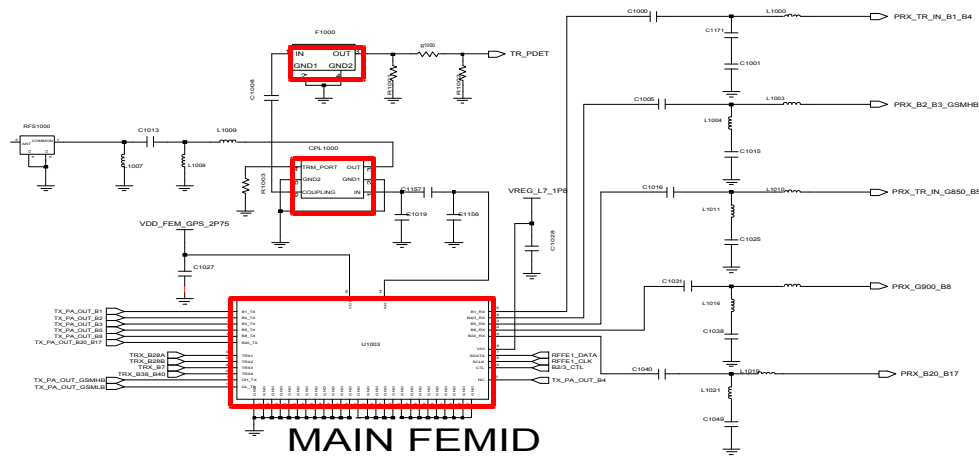

MMMB(GSM_QUAD/WLB1/WB2/WLB3/WLB5/WLB8/LB20)

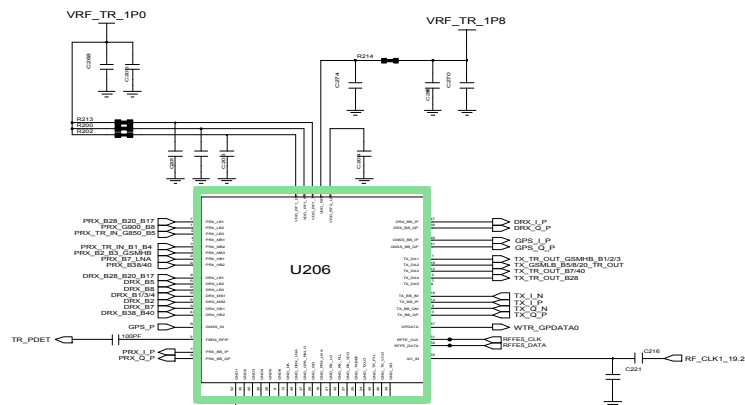
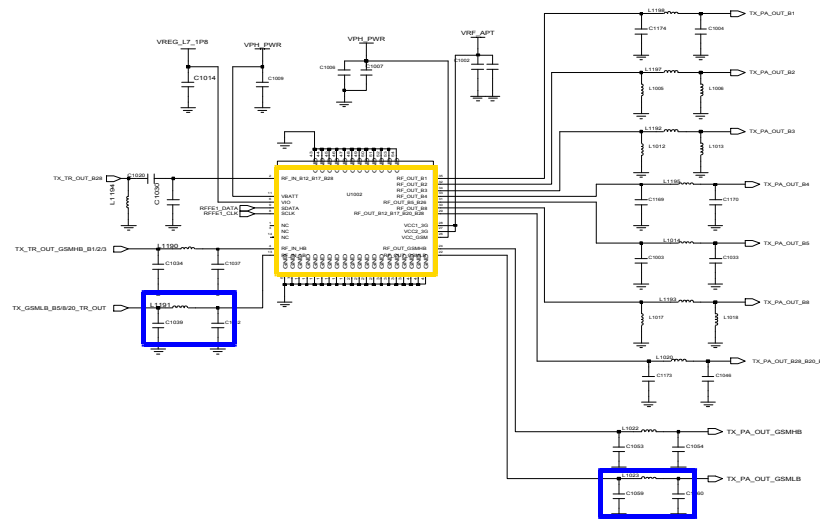

RF Transceiver

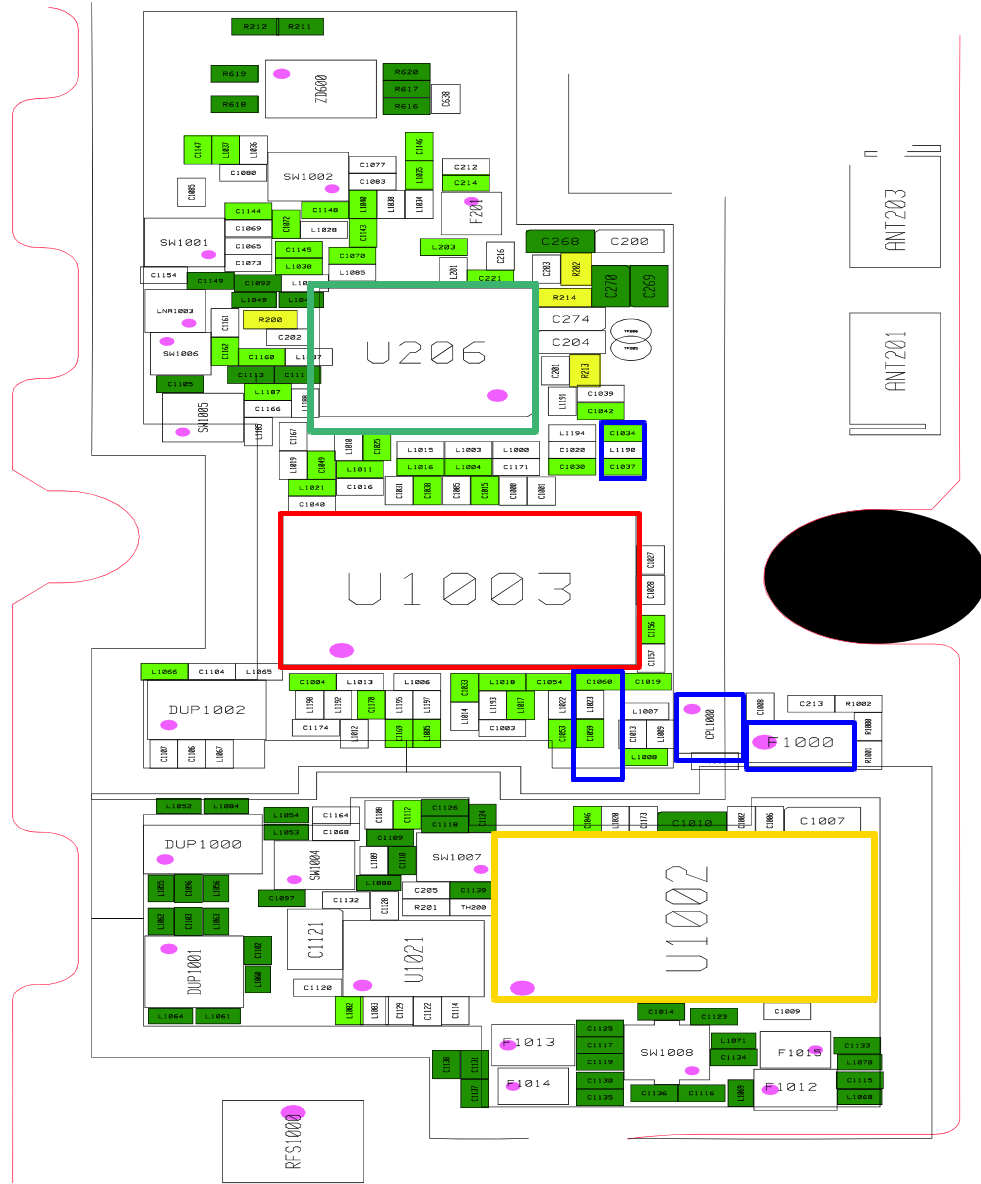

8-3-28. GSM1800 / GSM1900 TX

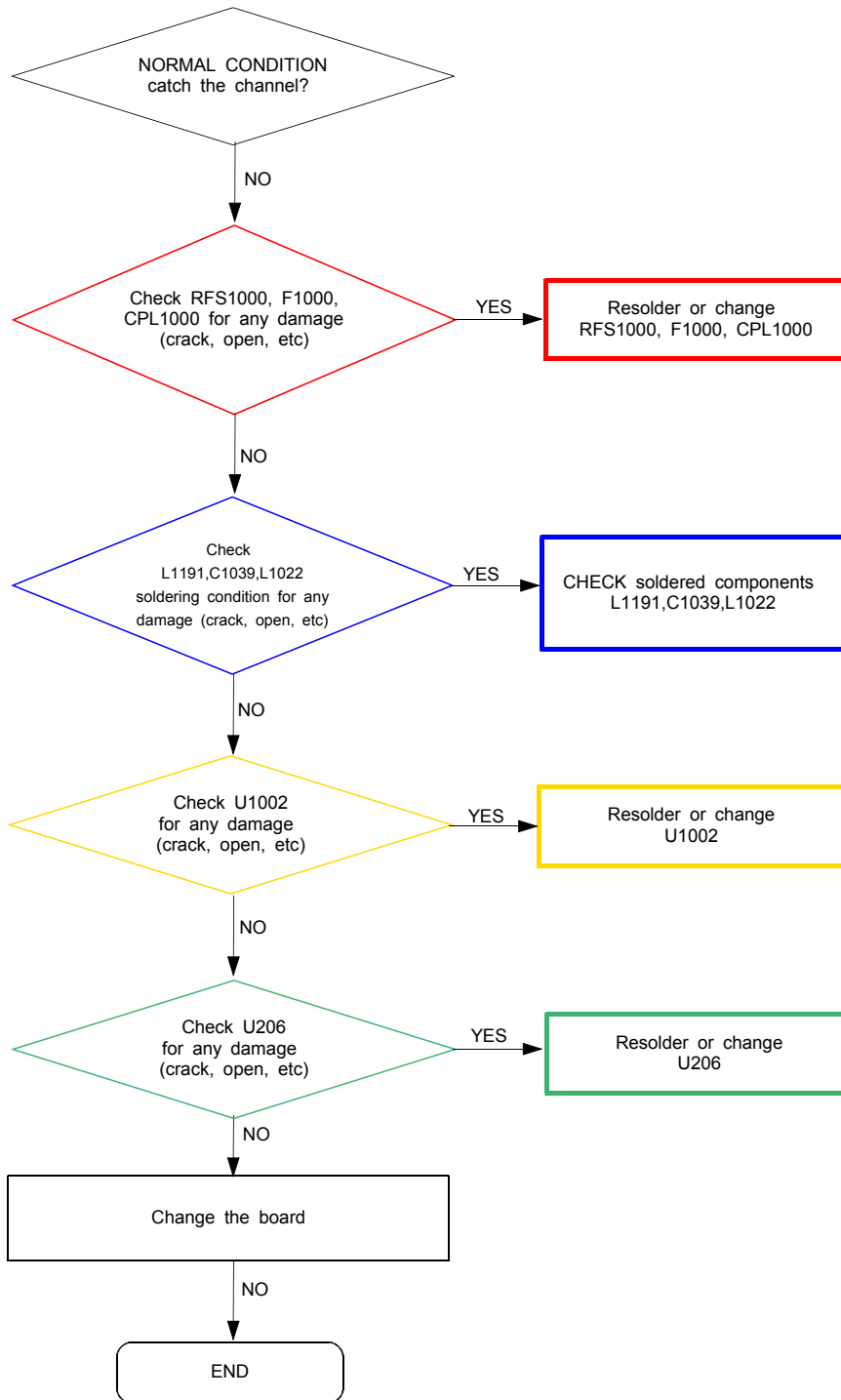

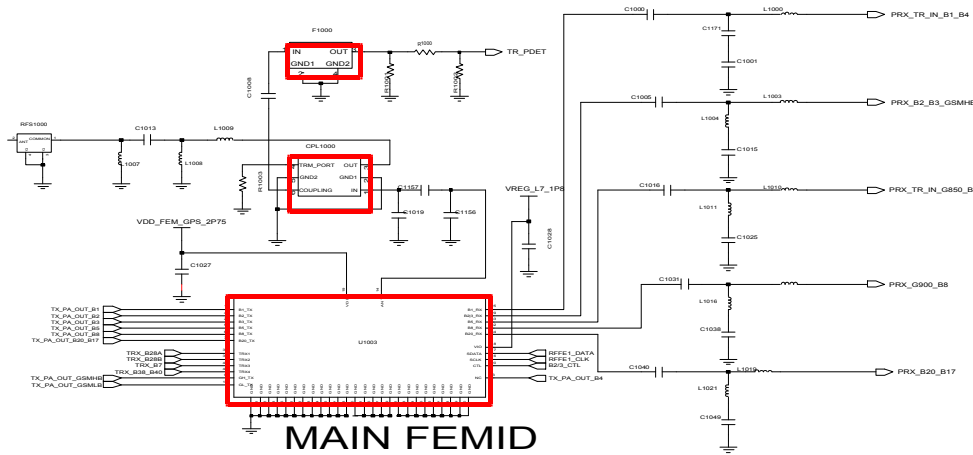

MAIN FEMID

MMMB(GSM_QUAD/WLB1/WB2/WLB3/WLB5/WLB8/LB20)

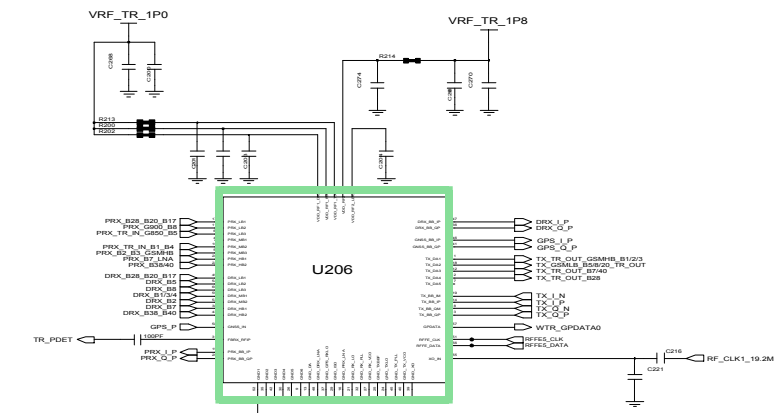
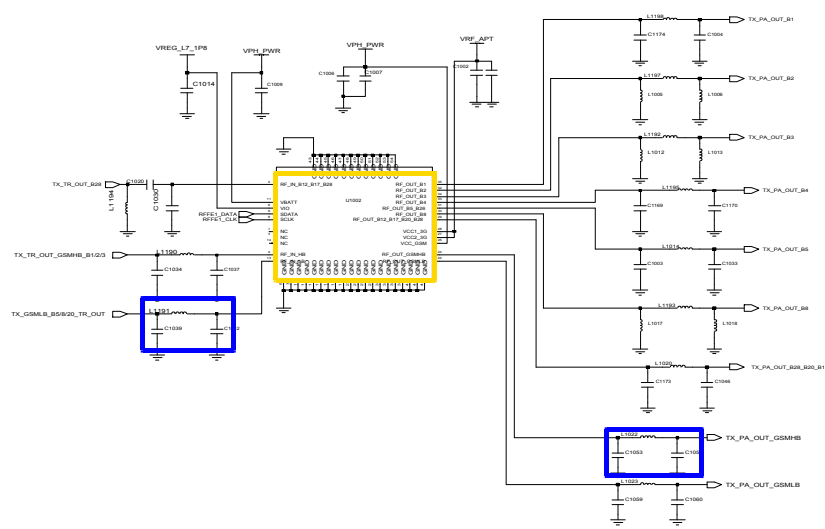

RF Transceiver

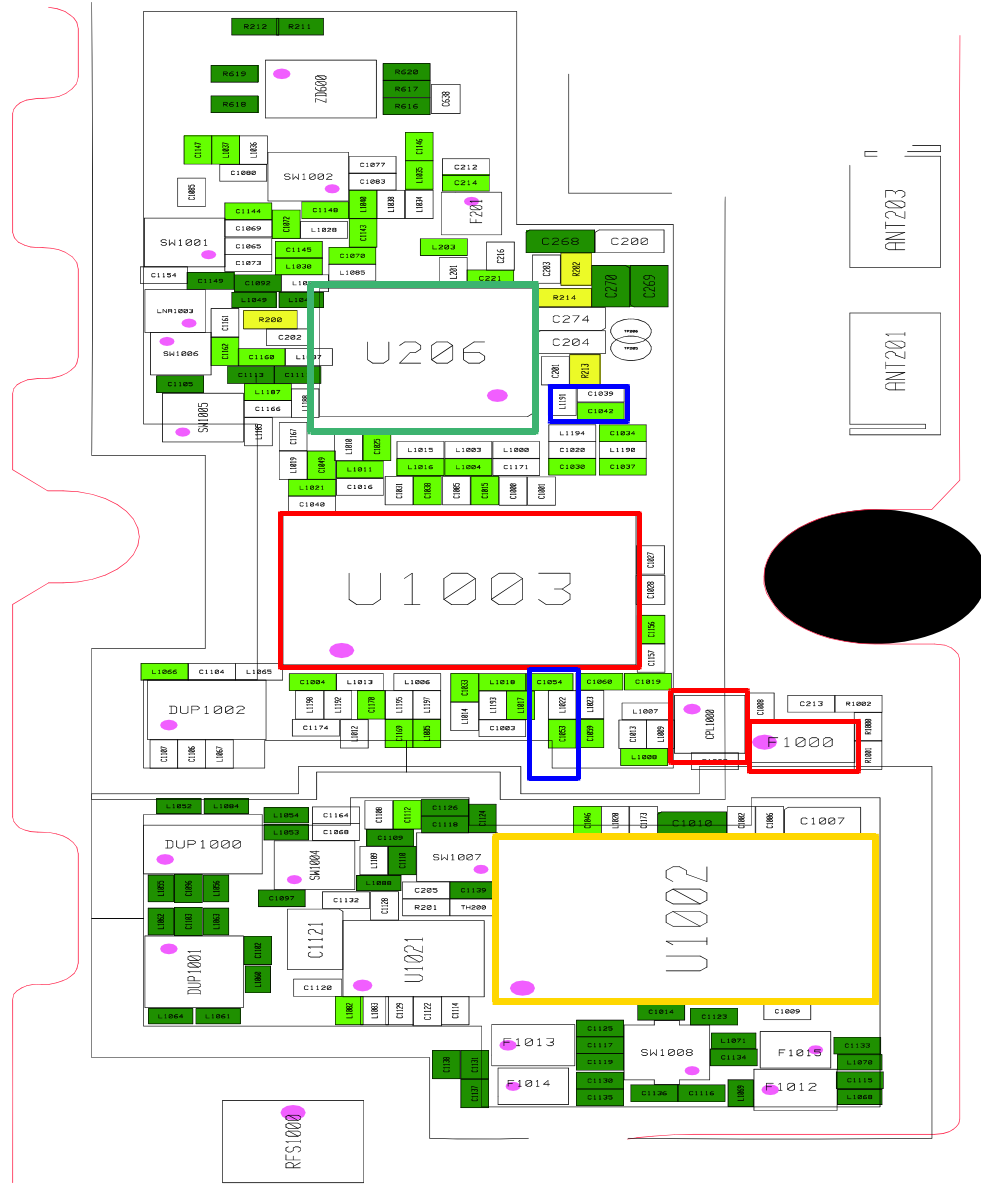

8-3-29. WCDMA B1 / LTE1 TX

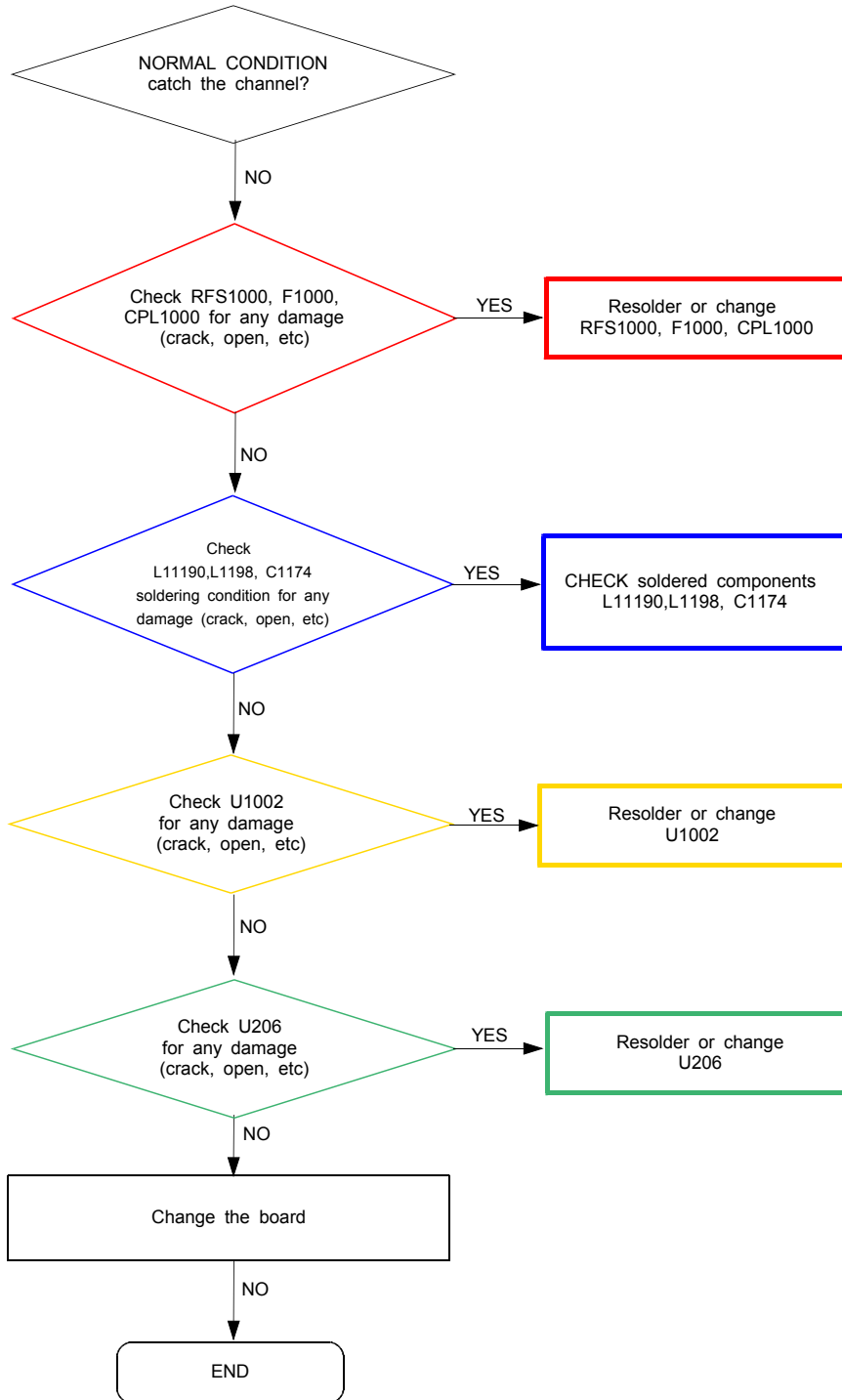

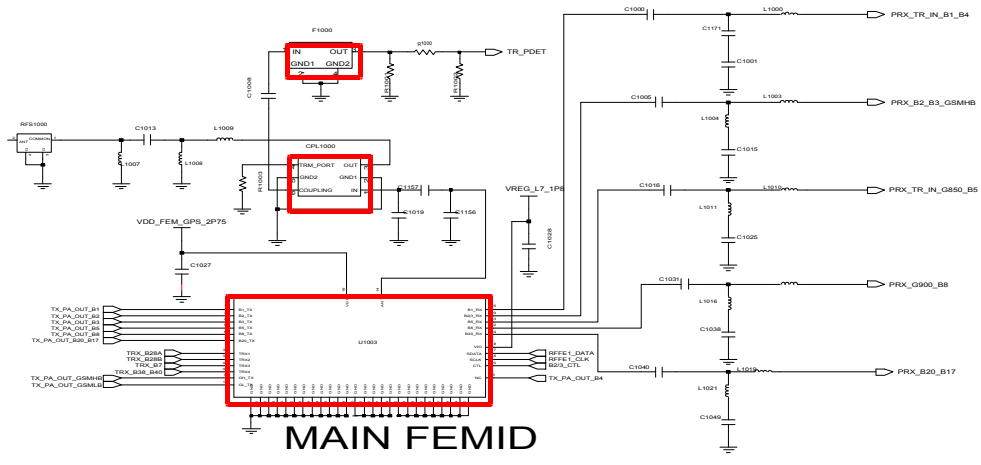

MMMB(GSM_QUAD/WLB1/WB2/WLB3/WLB5/WLB8/LB20)

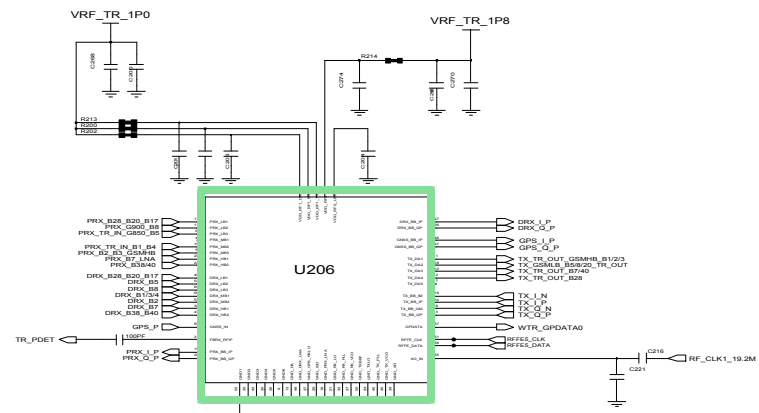
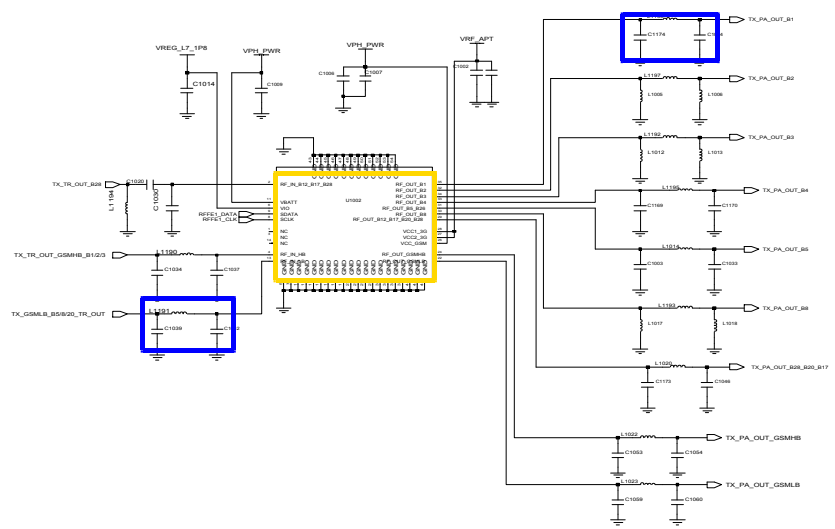

RF Transceiver

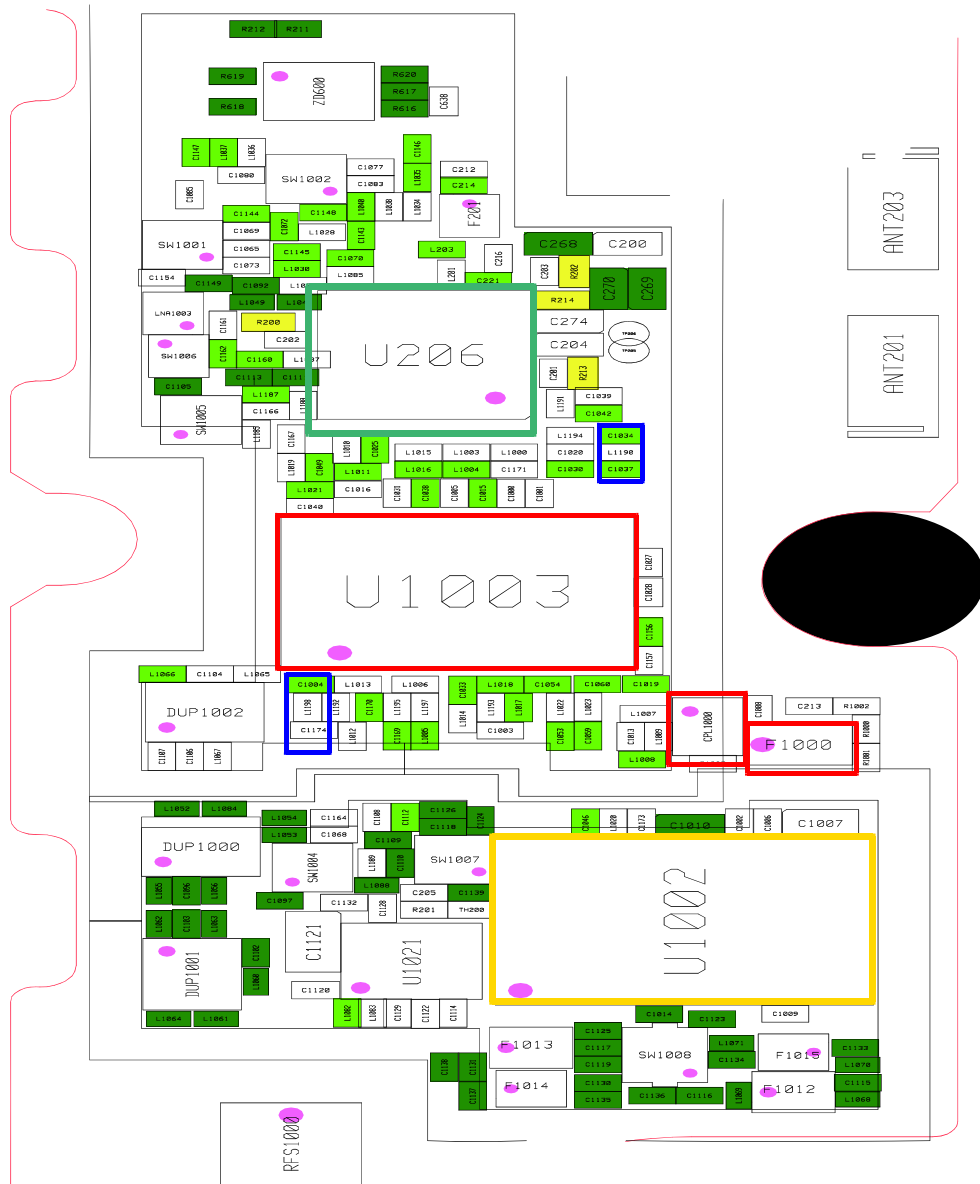

8-3-30. WCDMA B2 TX

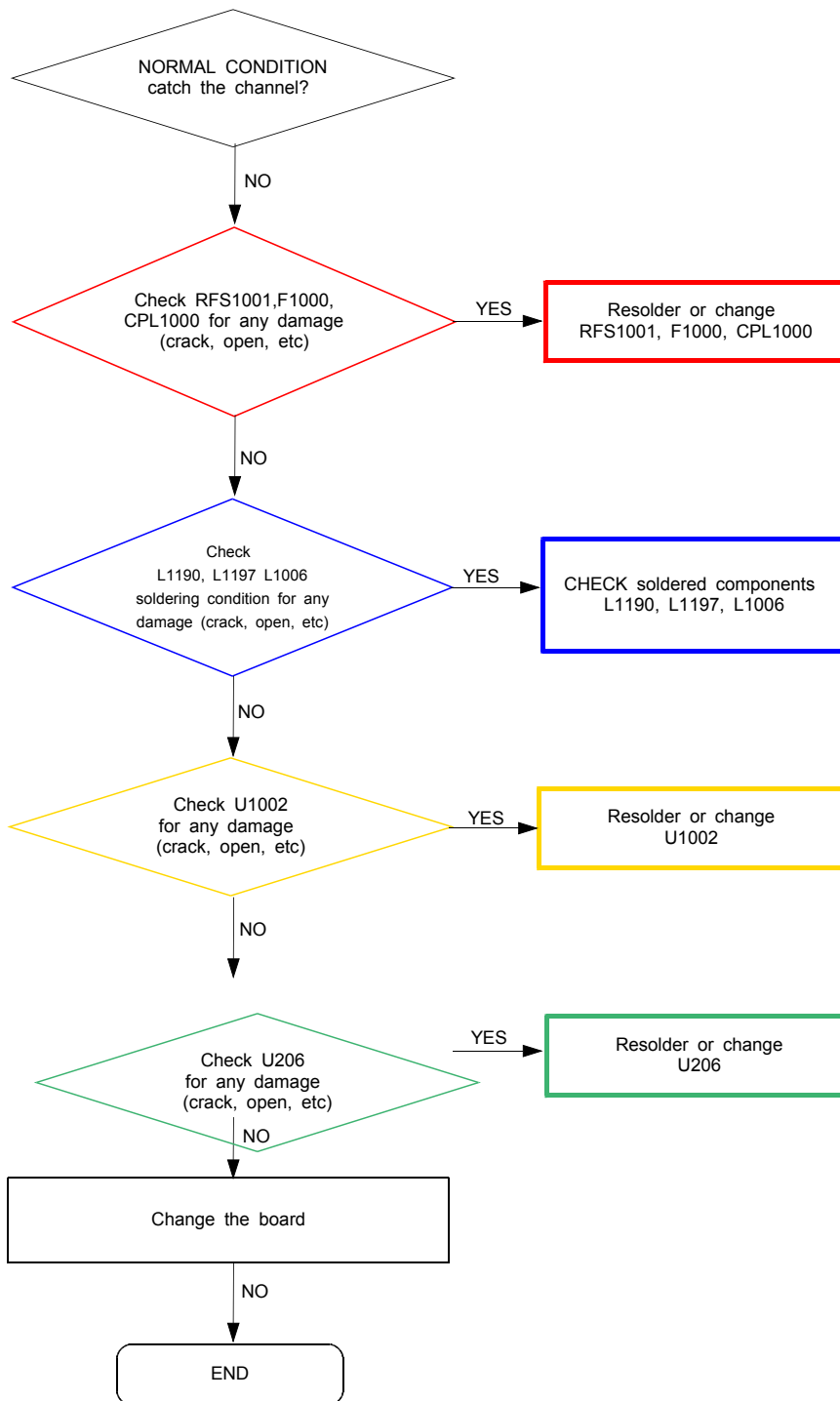

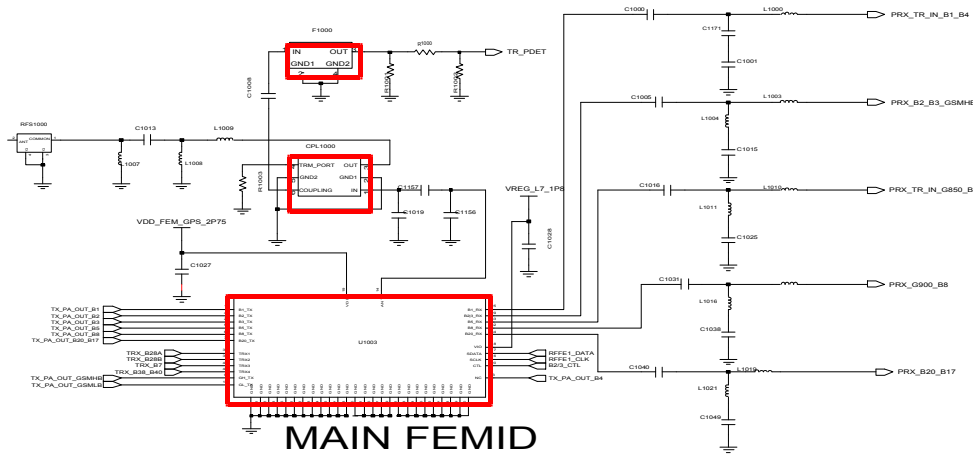

MMMB(GSM_QUAD/WLB1/WB2/WLB3/WLB5/WLB8/LB20)

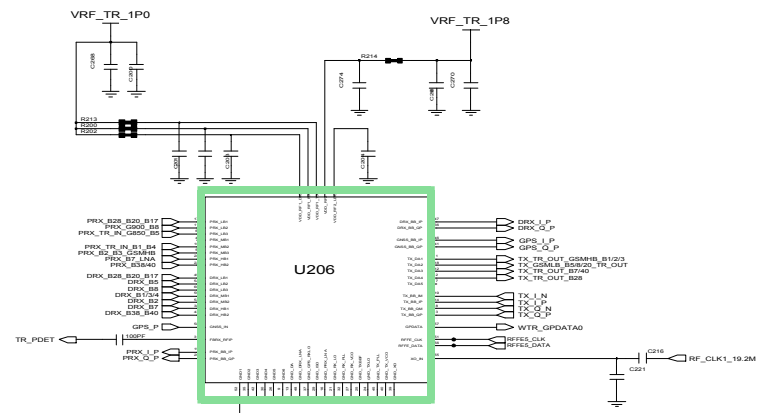
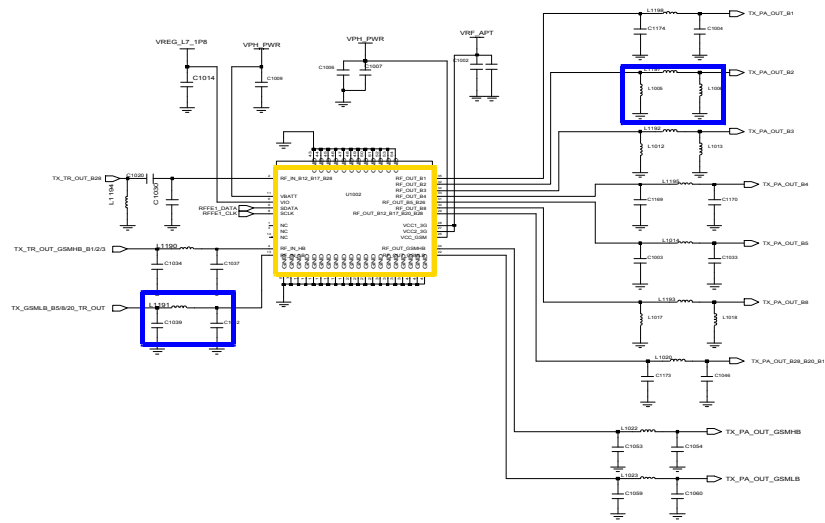

RF Transceiver

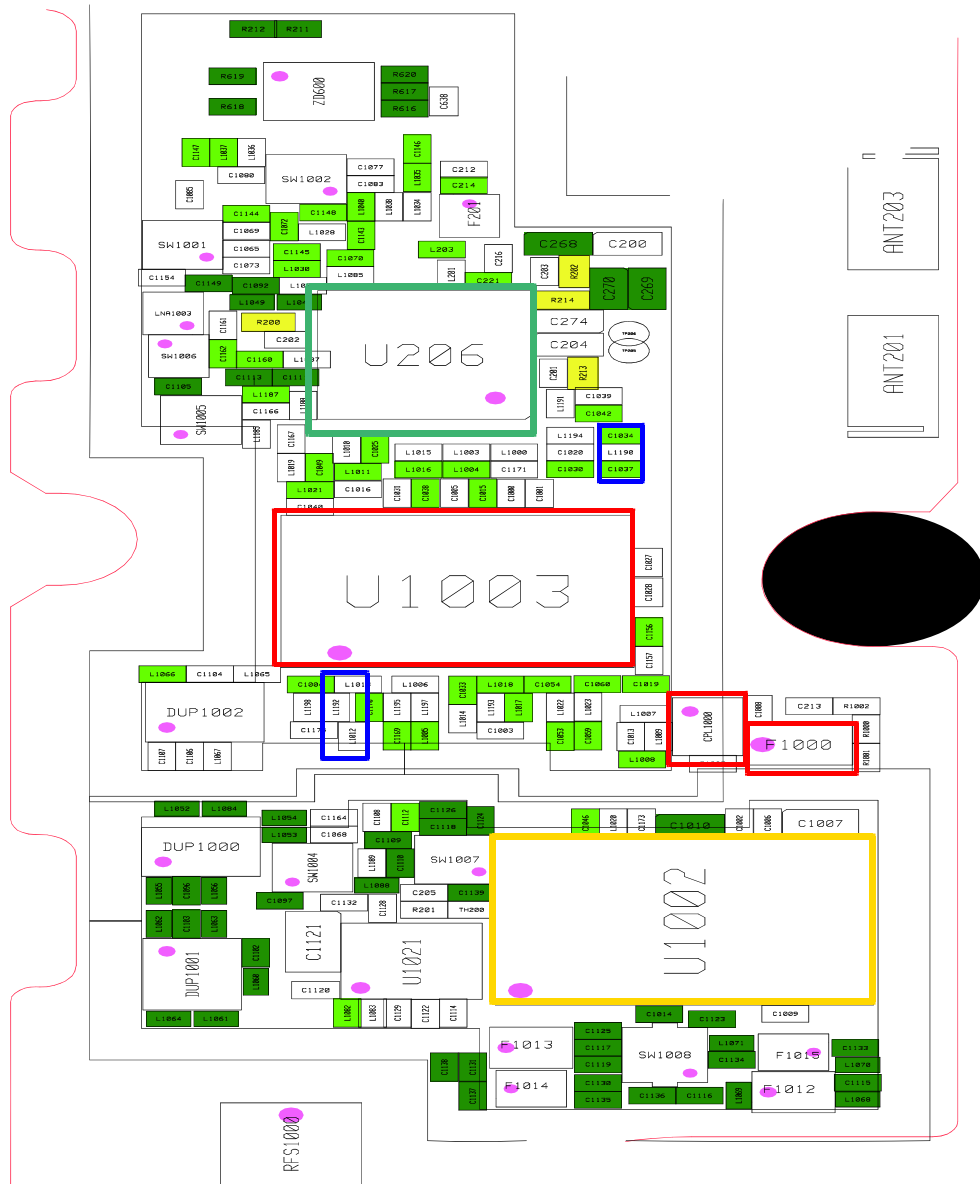

8-3-31. WCDMA B5 / LTE5 TX

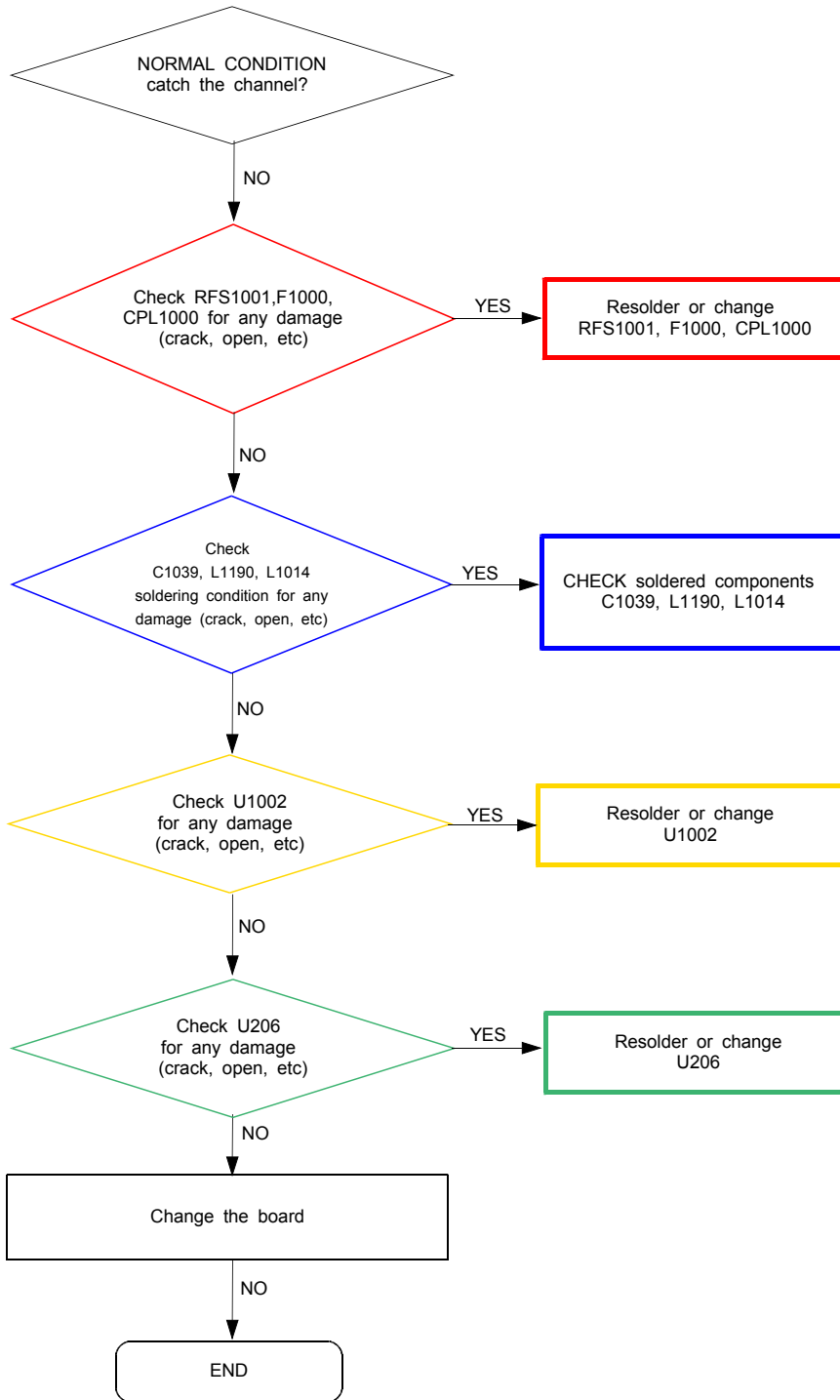

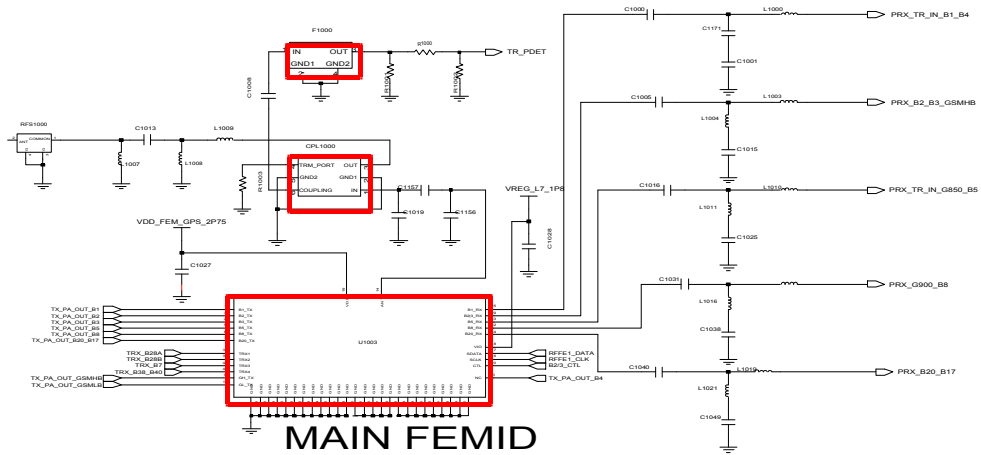

MAIN FEMID

MMMB(GSM_QUAD/WLB1/WB2/WLB3/WLB5/WLB8/LB20)

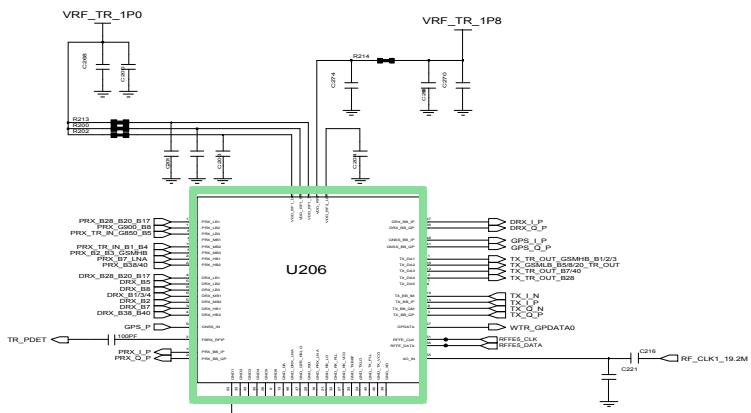
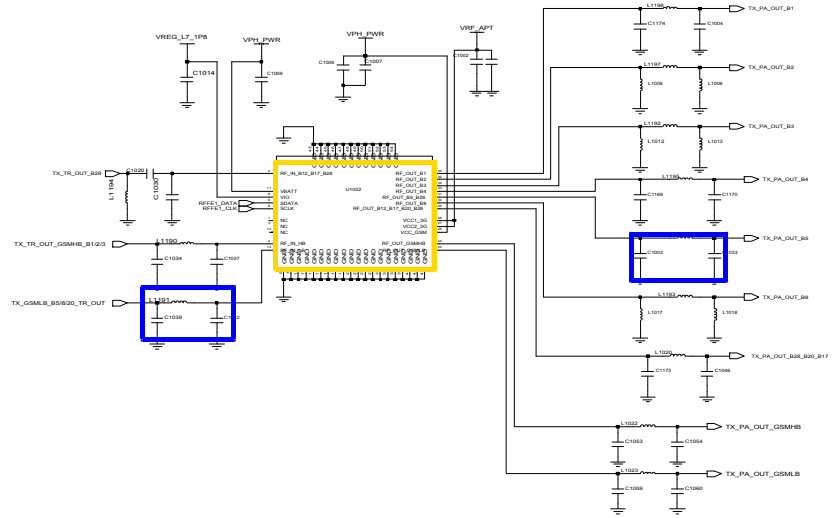

RF Transceiver

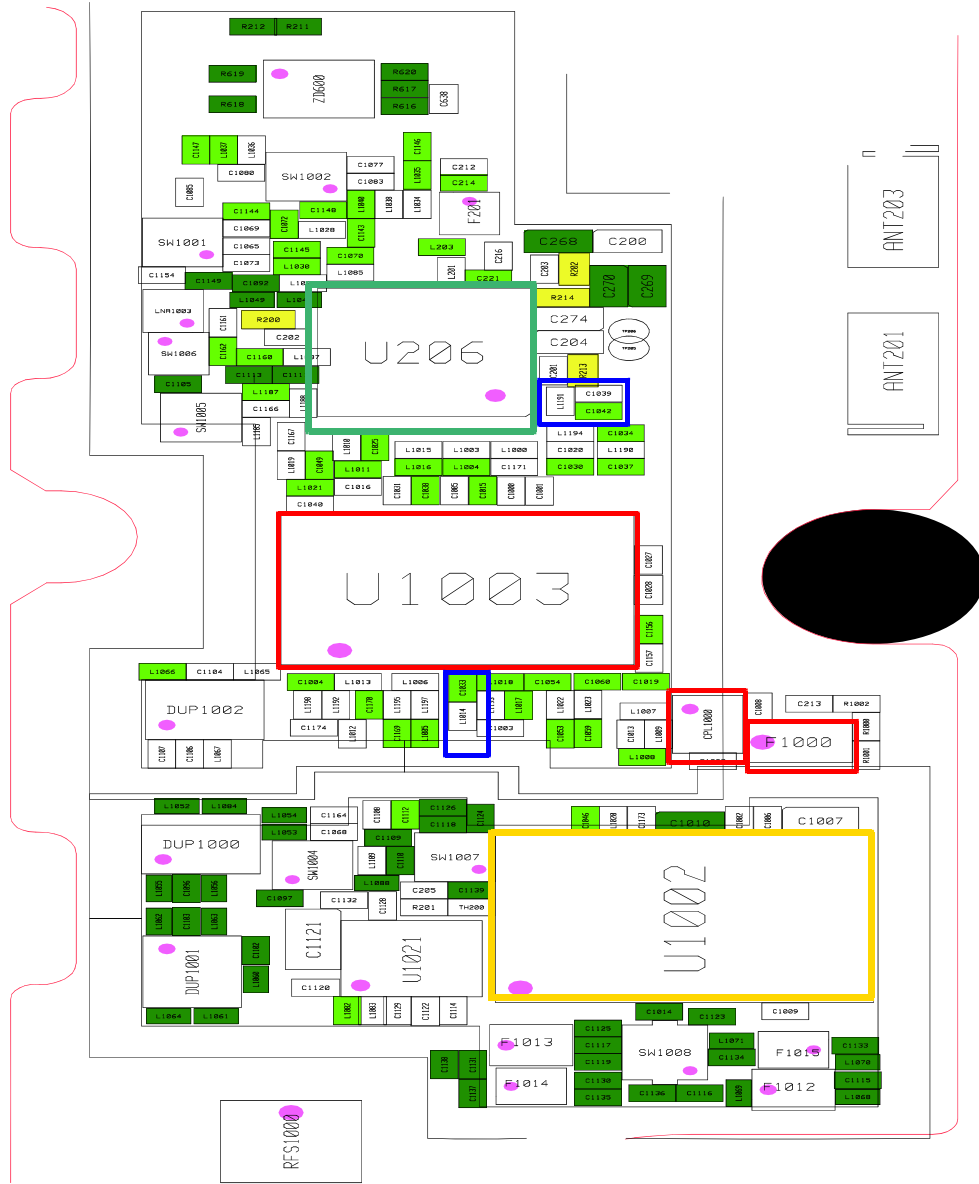

8-3-32. WCDMA B8 / LTE8 TX

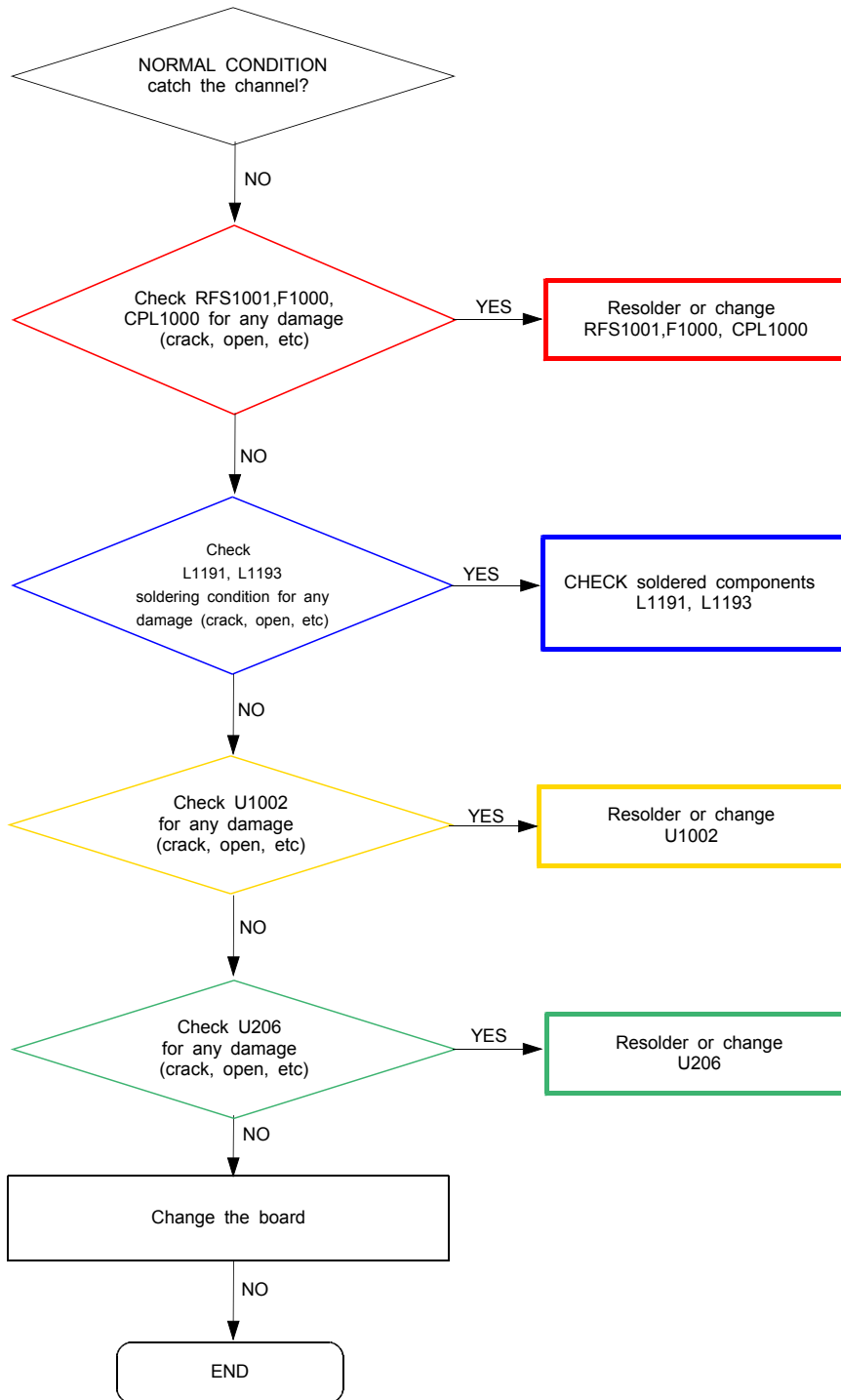

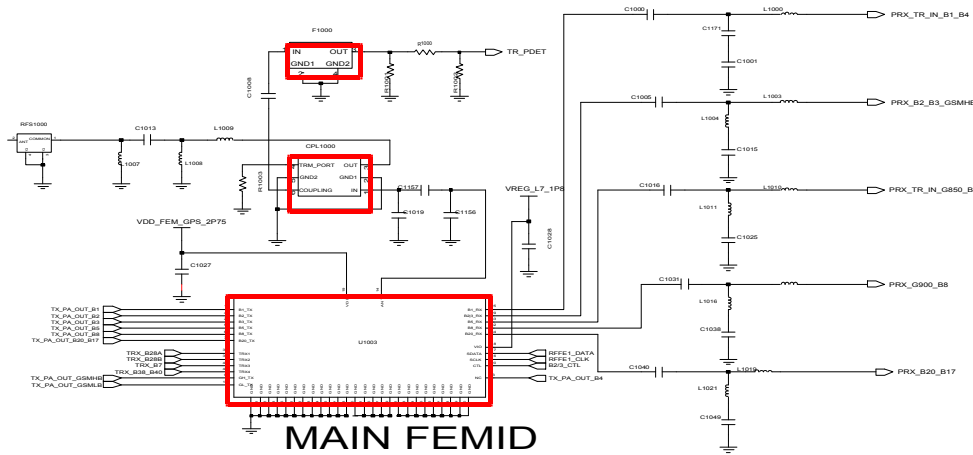

MAIN FEMID

MMMB(GSM_QUAD/WLB1/WB2/WLB3/WLB5/WLB8/LB20)

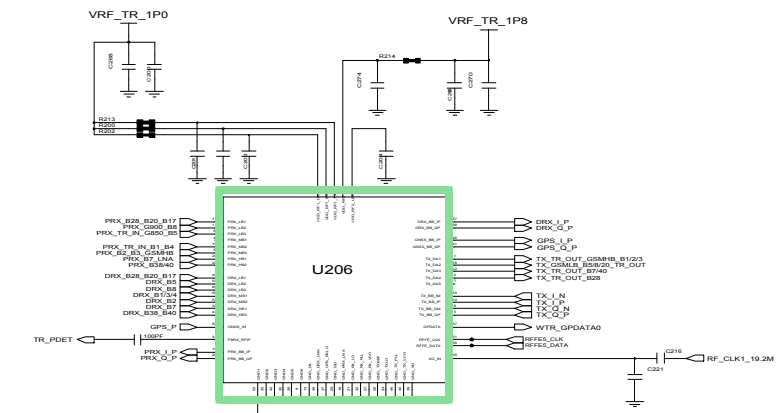
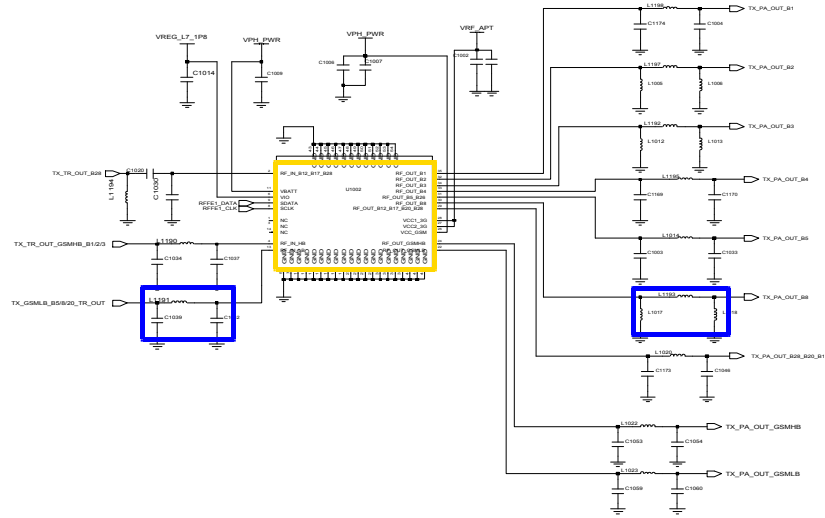

RF Transceiver

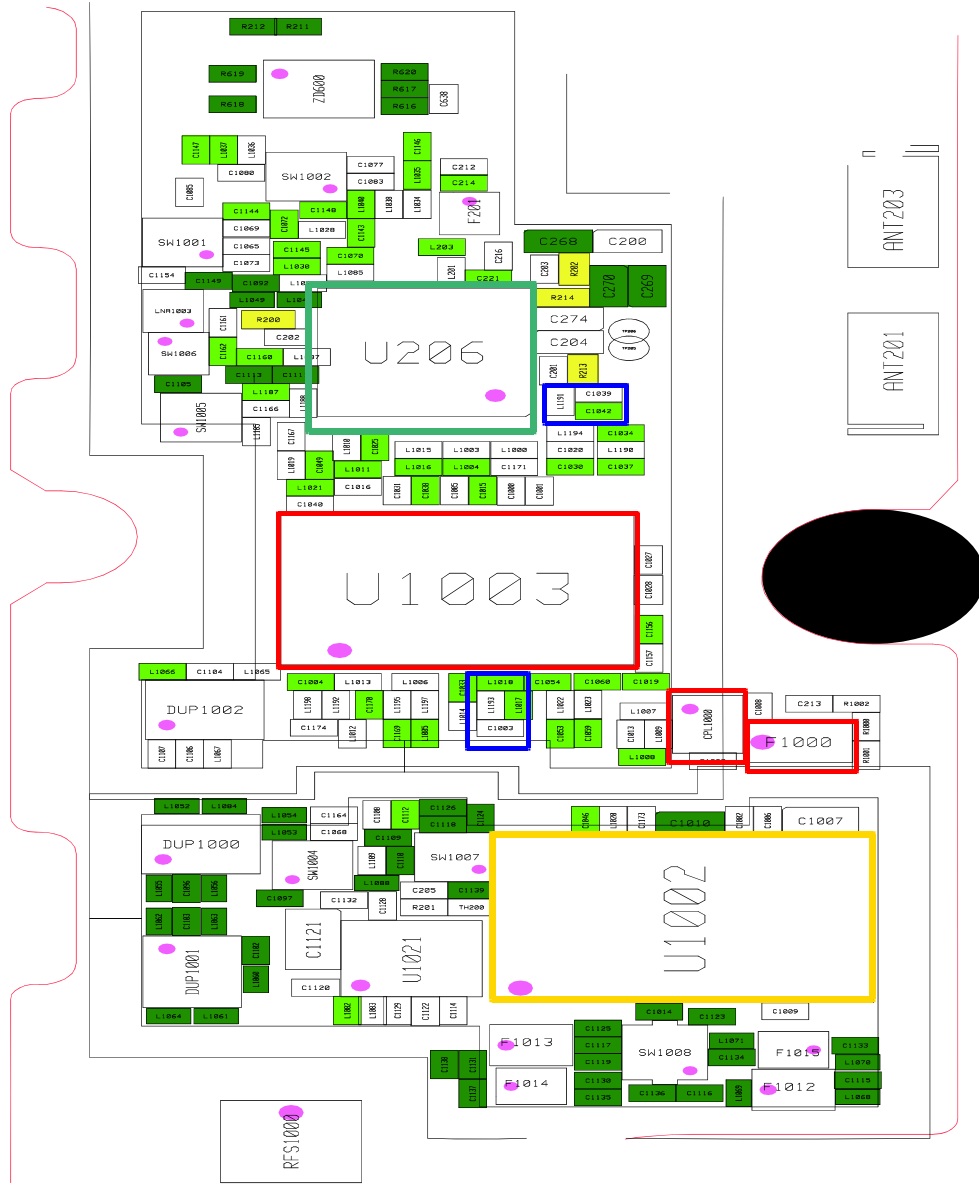

8-3-33. LTE3 TX

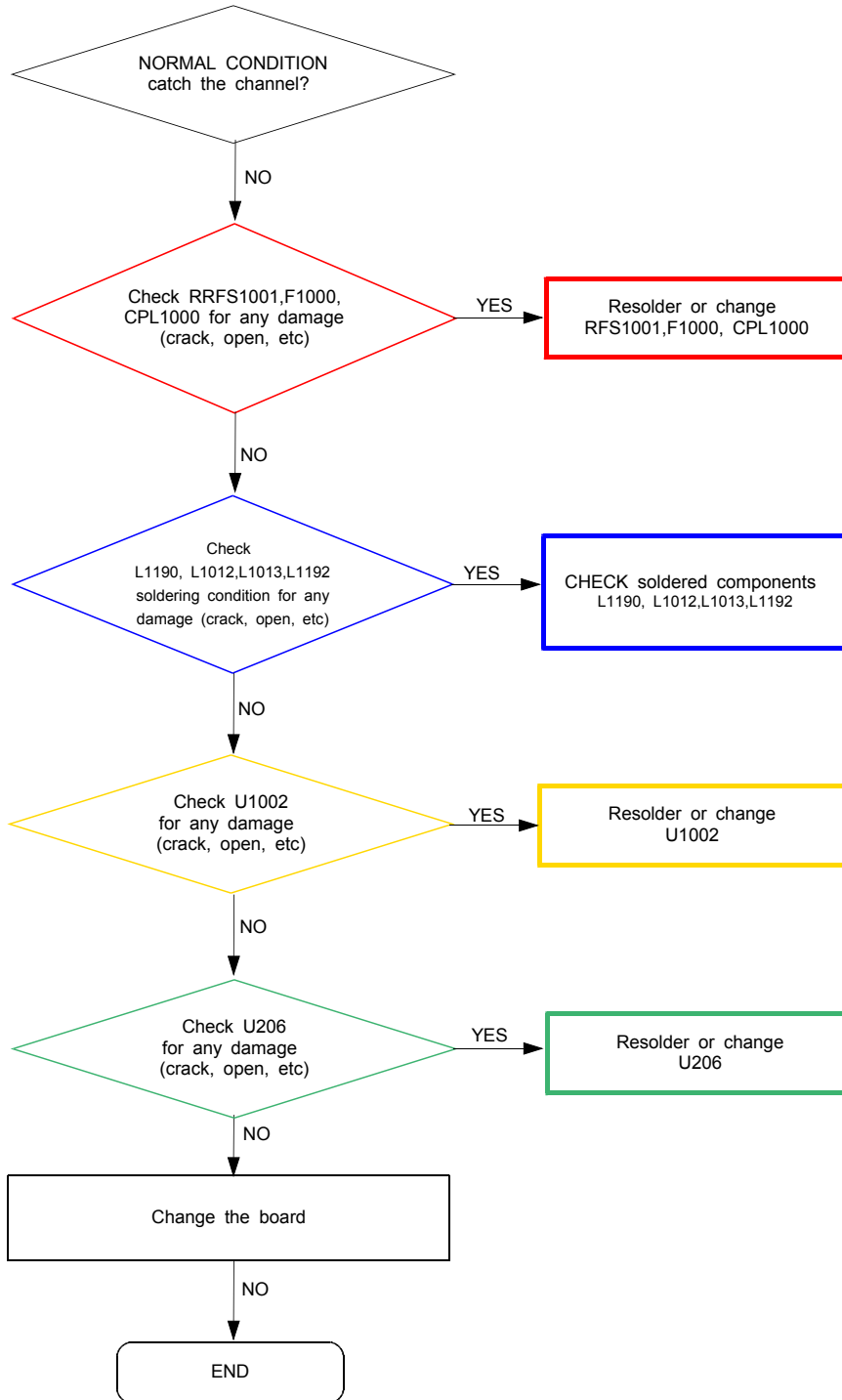

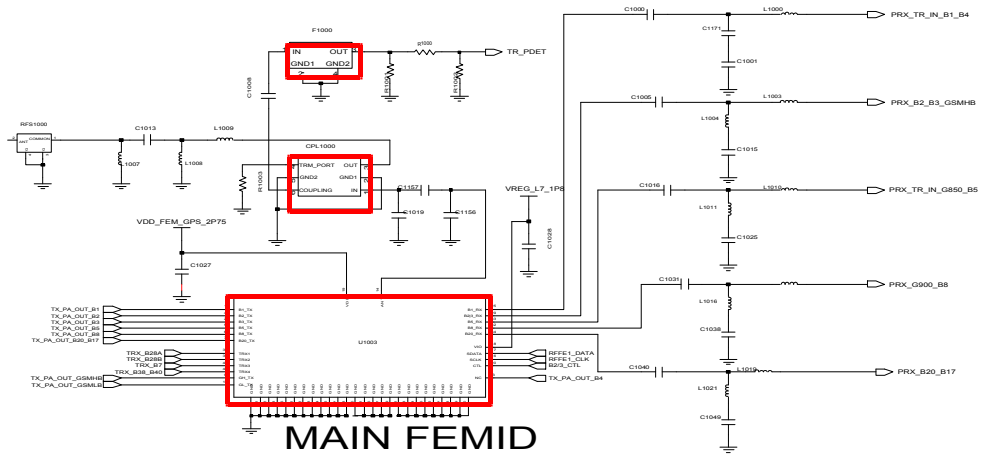

MMMB(GSM_QUAD/WLB1/WB2/WLB3/WLB5/WLB8/LB20)

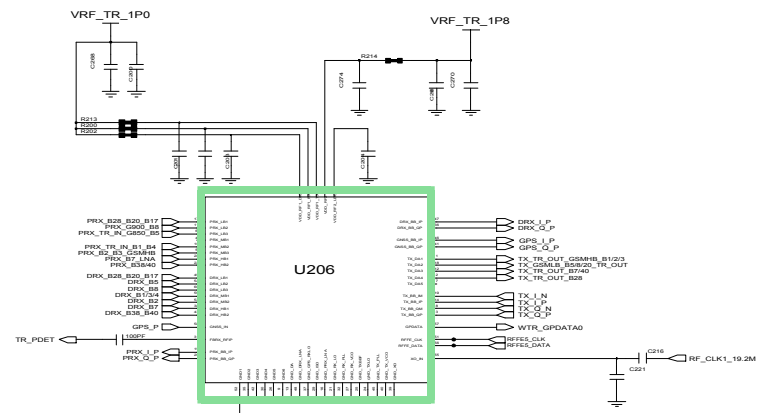
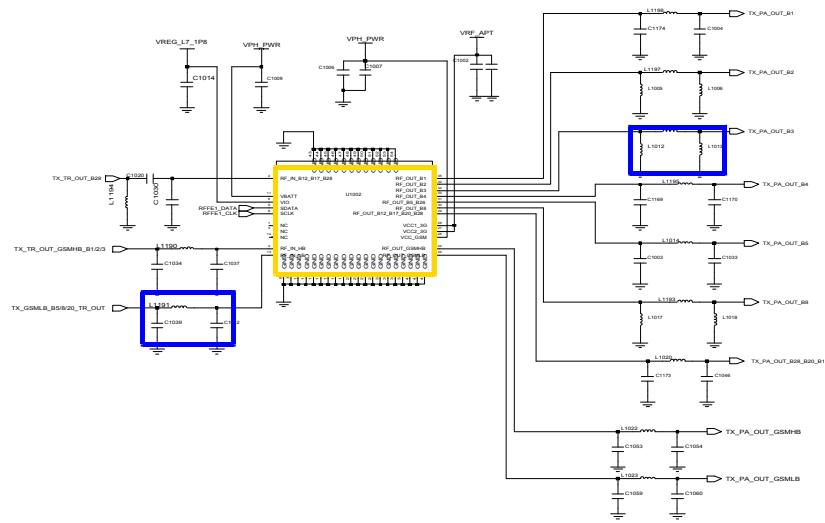

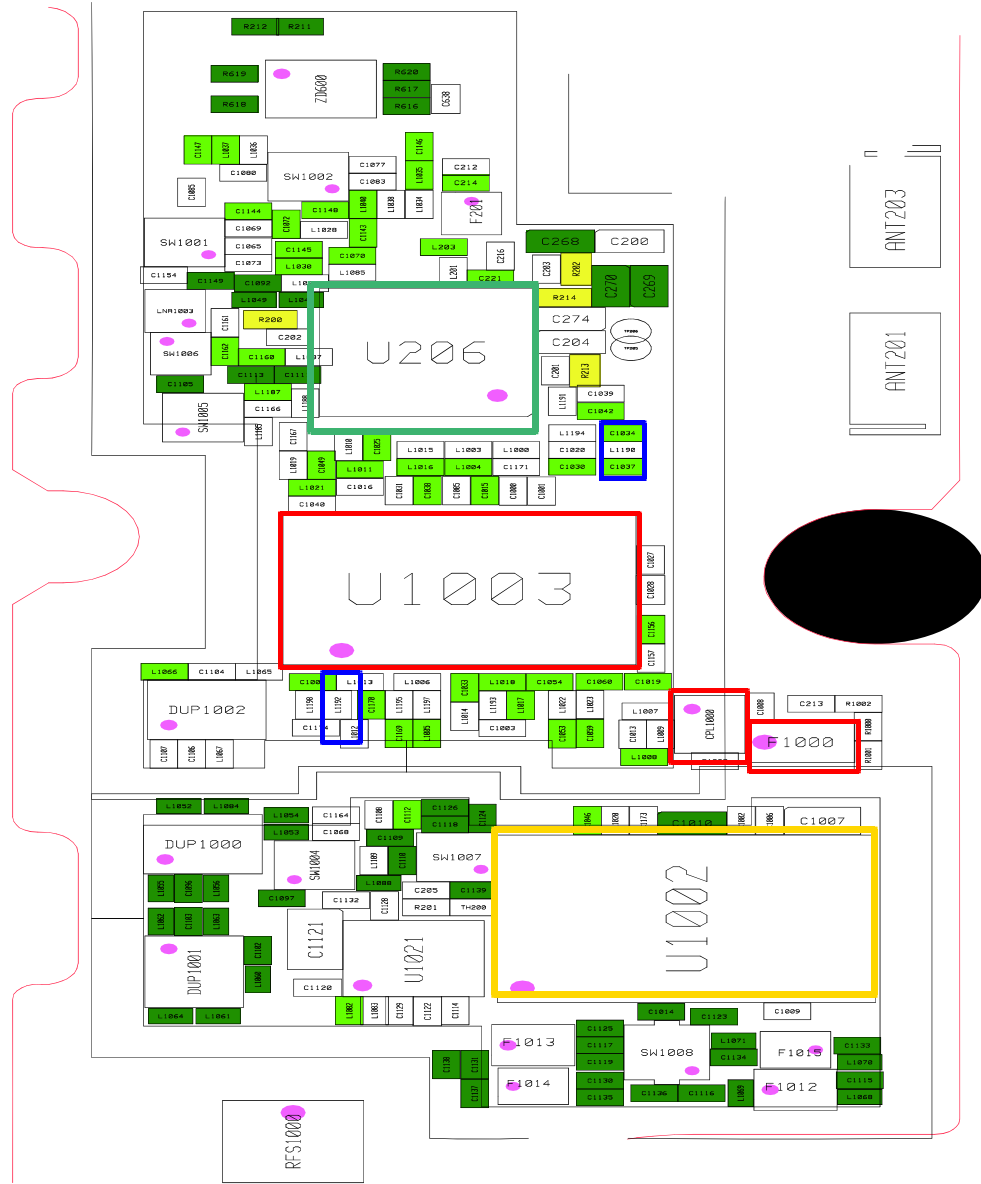

8-3-34. LTE7 TX

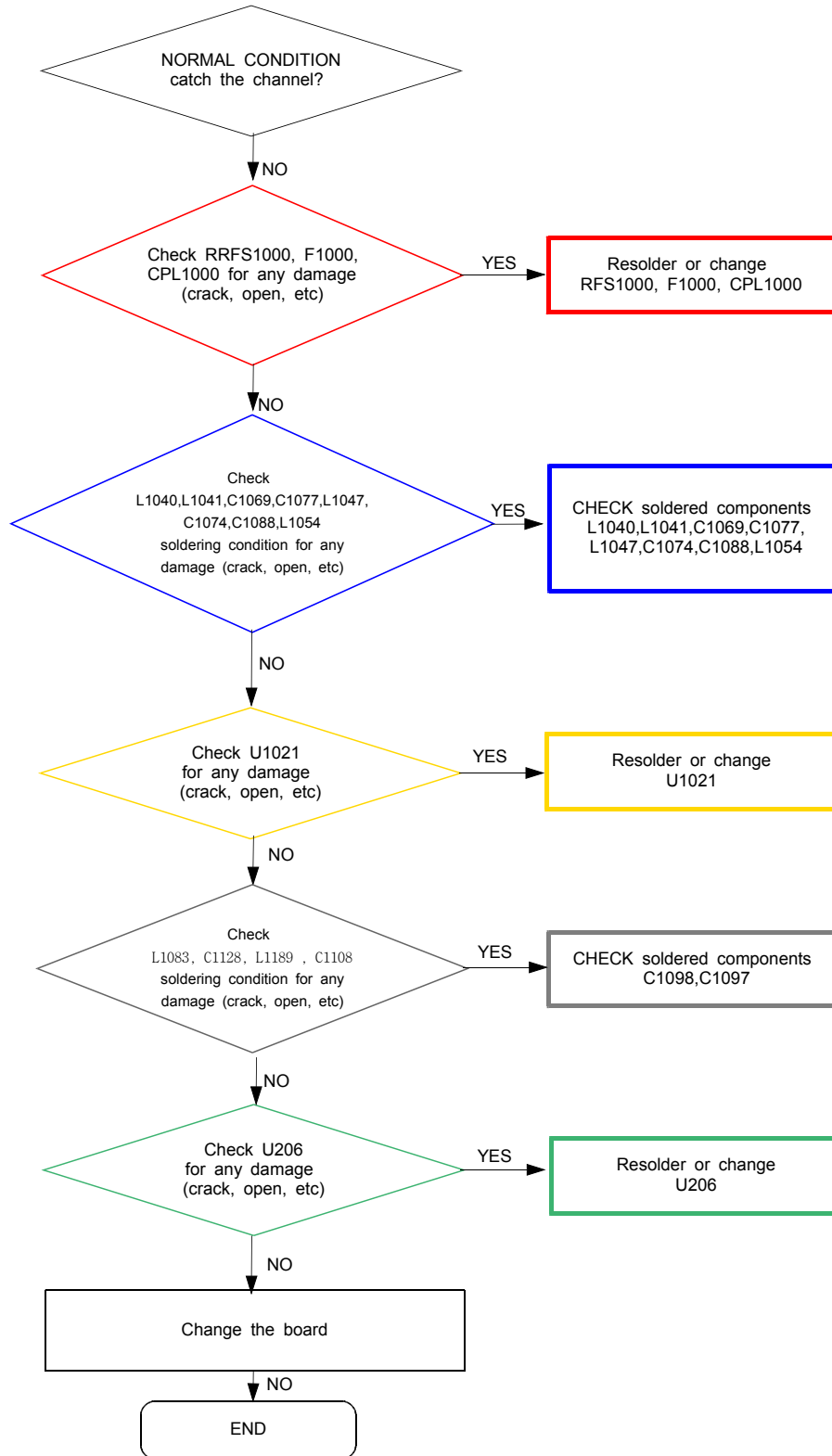

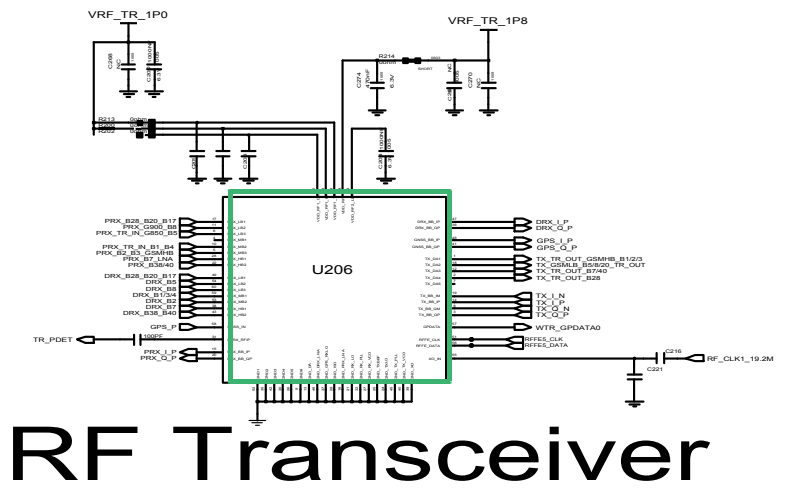
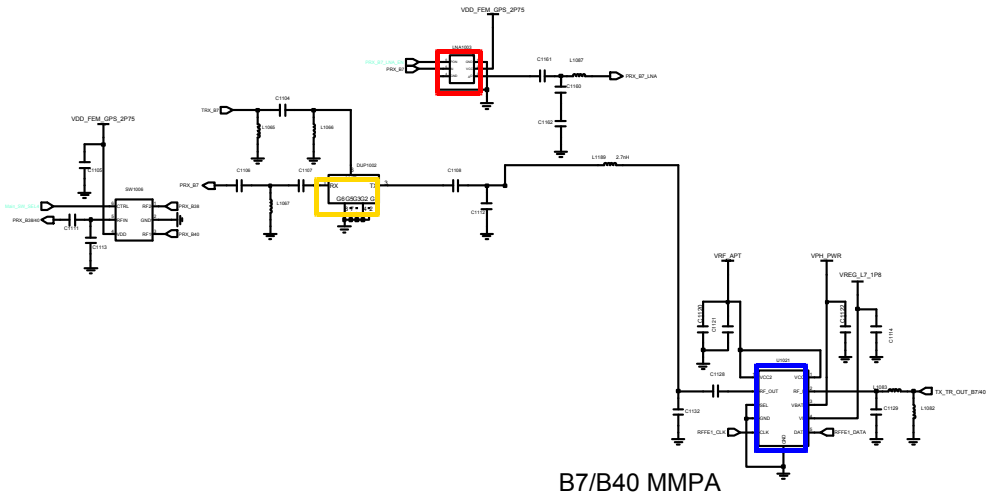
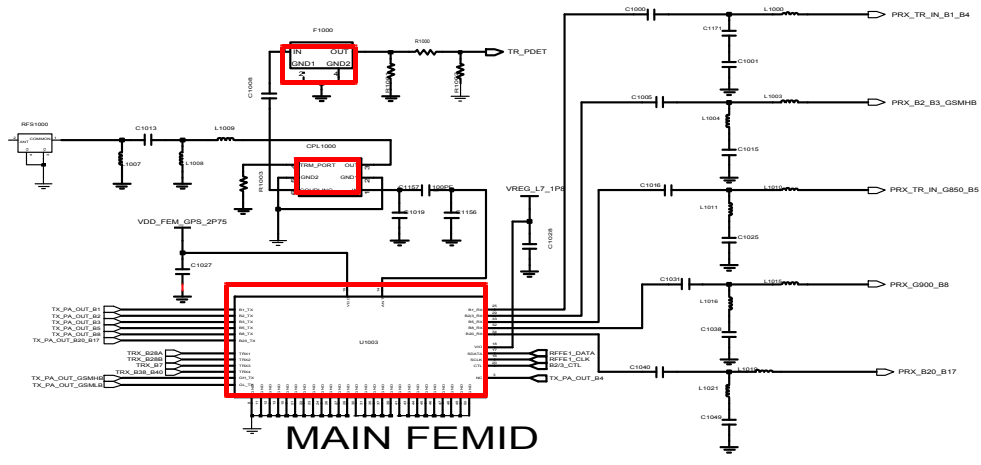

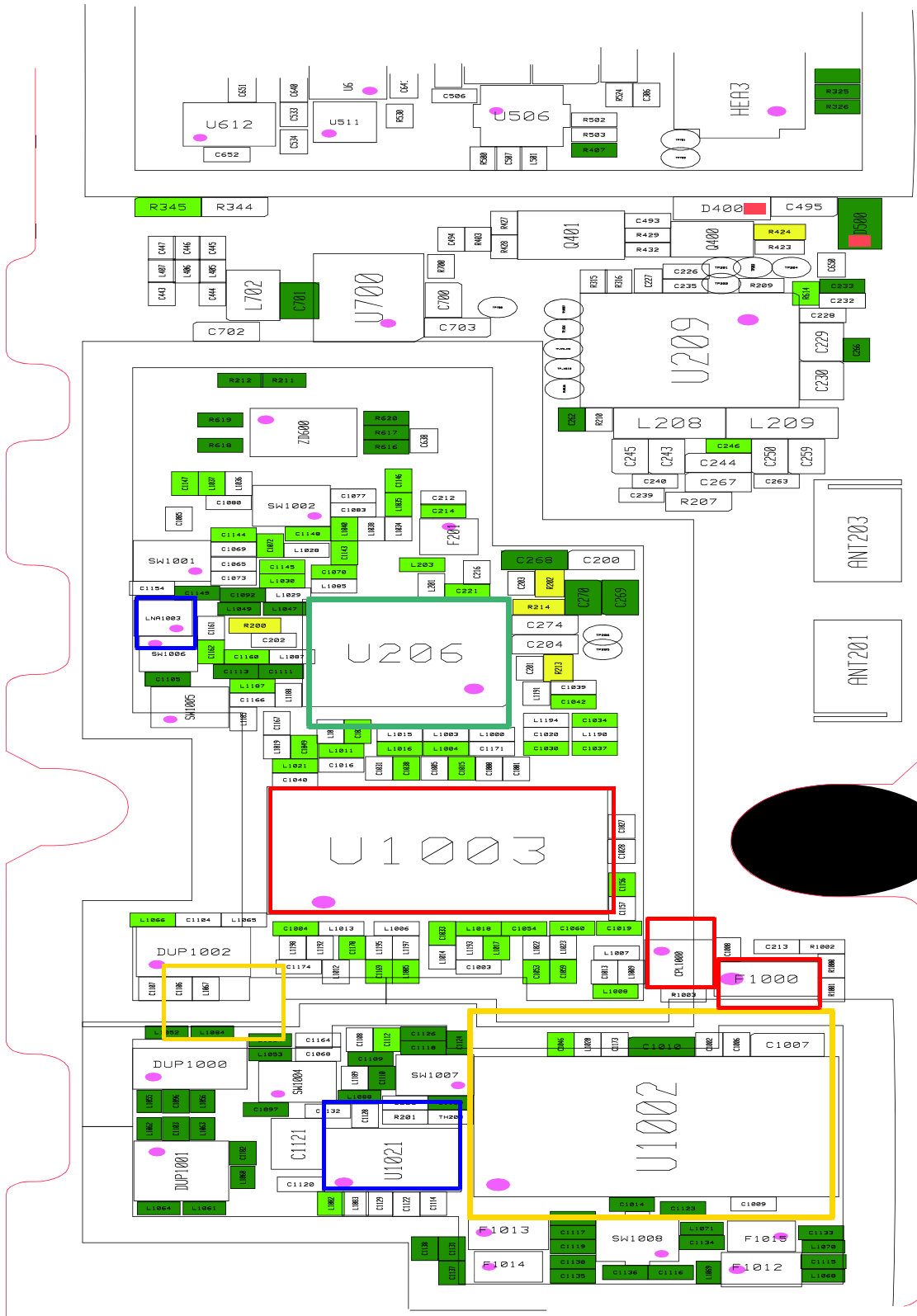

8-3-35. LTE20 TX

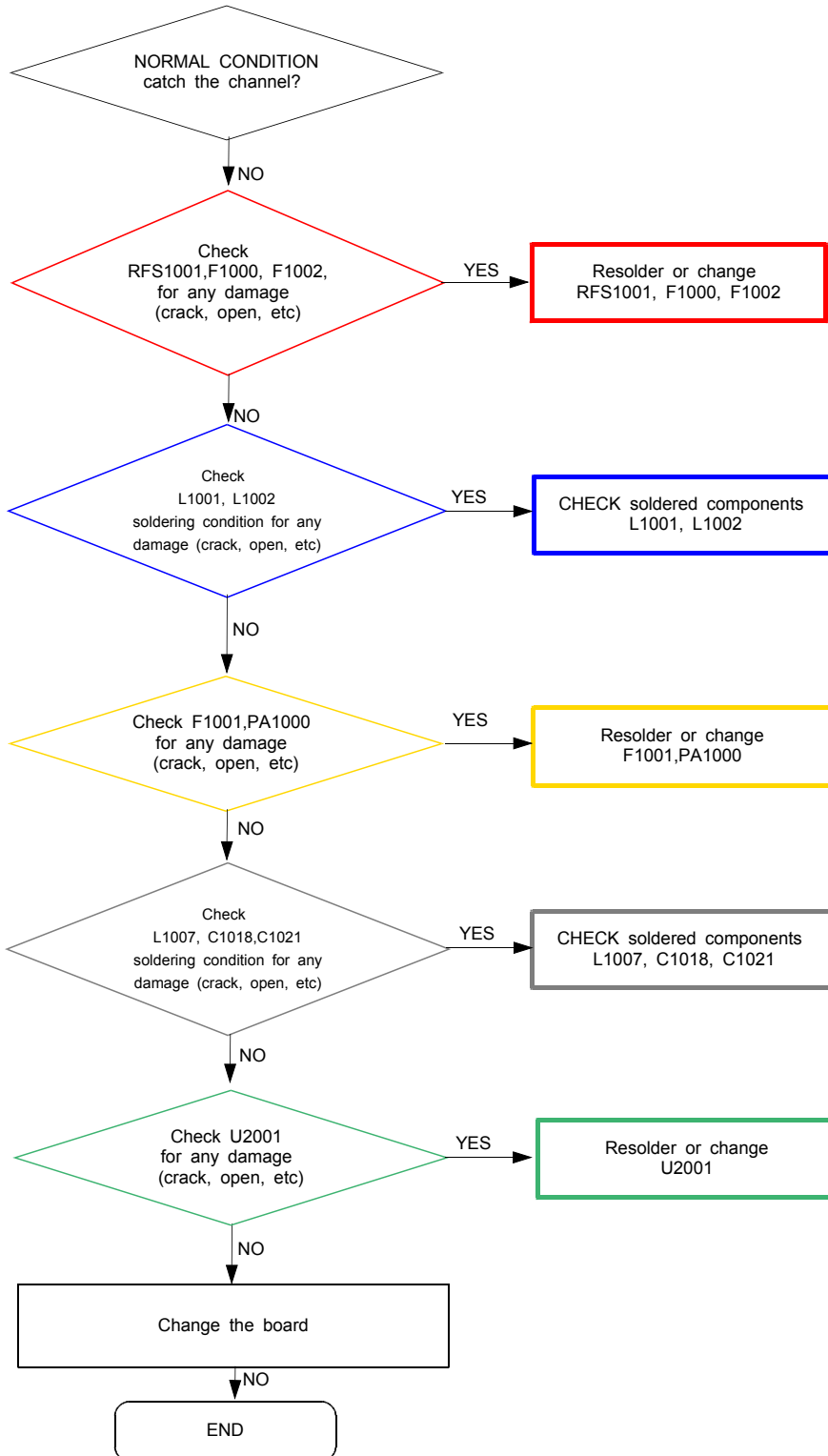

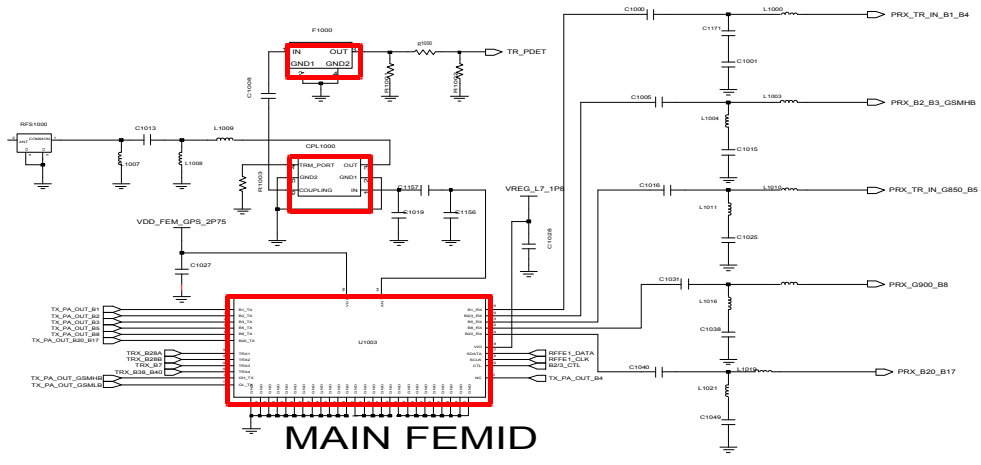

MMMB(GSM_QUAD/WLB1/WB2/WLB3/WLB5/WLB8/LB20)

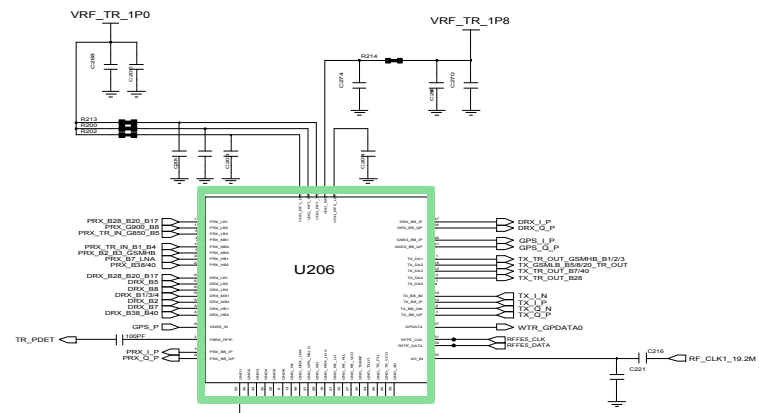
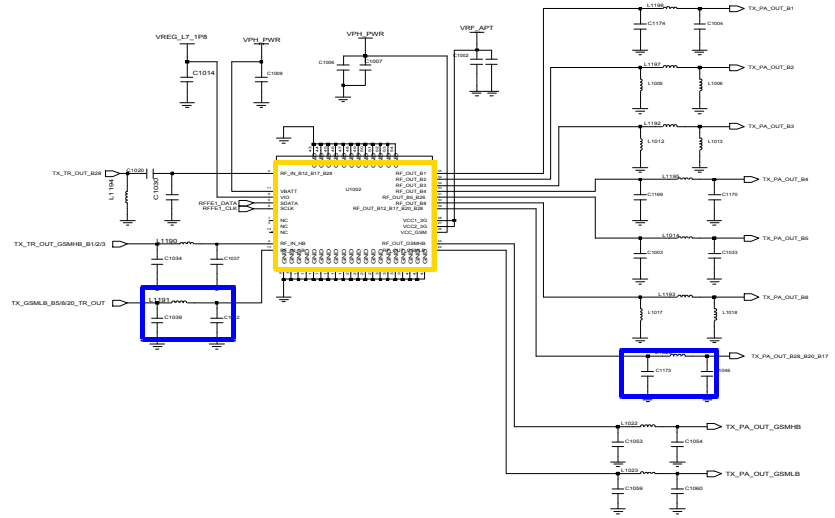

RF Transceiver

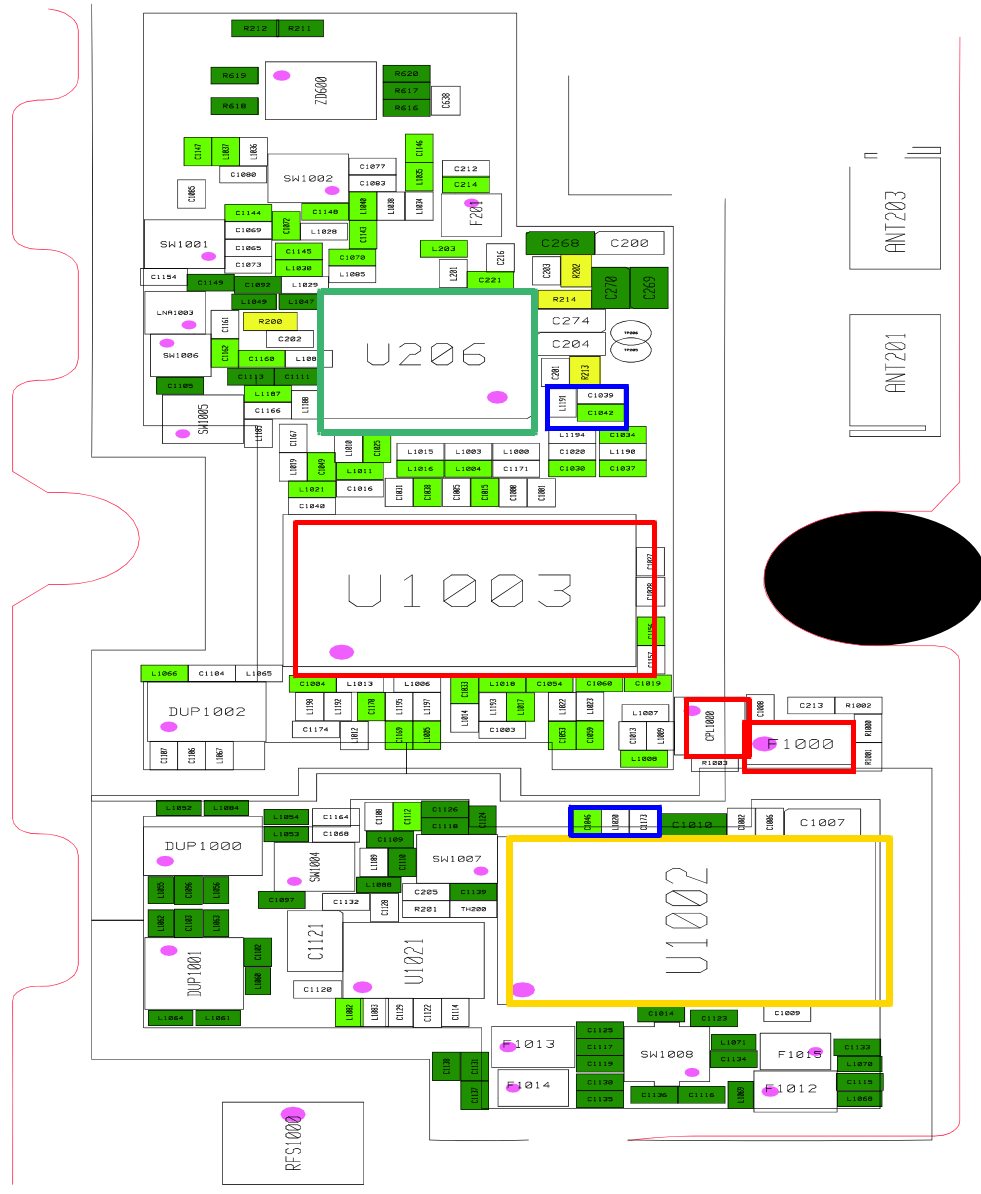

-NC Point(Top View)

●: NC

	1	2	3	4	5	6	7	8	9	10	11	12	13	14
A														
B														
C	●													●
D	●							●	●	●	●	●	●	●
E	●	●	●	●	●	●	●	●	●	●	●	●	●	●
F	●					●	●							●
G	●					●	●							●
H	●					●	●							●
I	●					●	●							●
J	●					●	●							●
K	●					●	●							●
L	●					●	●							●
M	●					●	●							●
N	●					●	●							●
P	●					●	●							●
R	●					●	●							●
T	●					●	●							●
U	●					●	●							●
V	●					●	●							●
W	●					●	●							●
Y	●					●	●							●
AA						●	●							
AB						●	●							

UME400

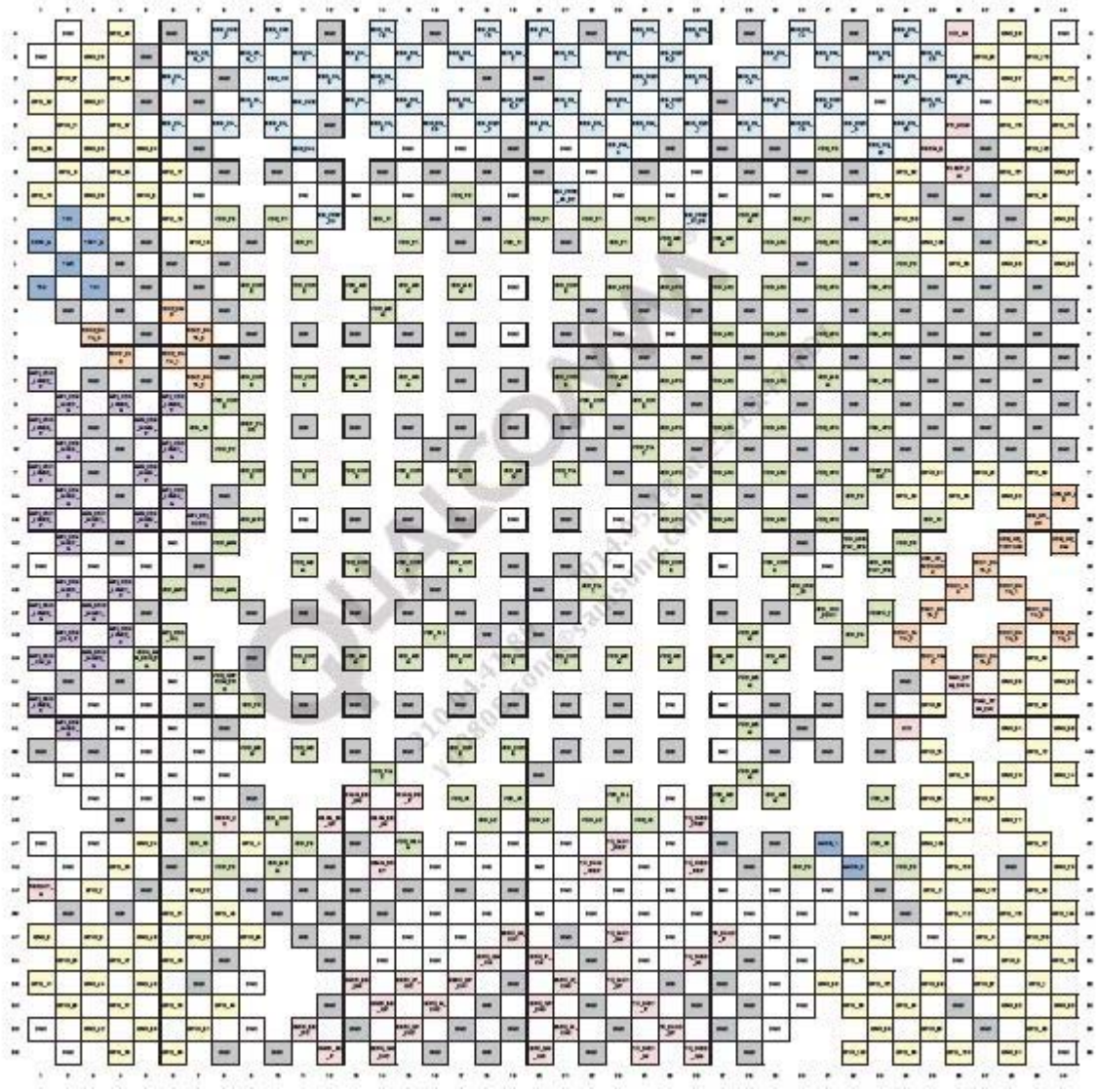

UCP300

	<u>1</u>	<u>2</u>	<u>3</u>	<u>4</u>	<u>5</u>	<u>6</u>	<u>7</u>	<u>8</u>	<u>9</u>	<u>10</u>	<u>11</u>	<u>12</u>	<u>13</u>	<u>14</u>
<u>A</u>														
<u>B</u>														
<u>C</u>									●					
<u>D</u>							●	●						
<u>E</u>					●									
<u>F</u>			●		●									
<u>G</u>														
<u>H</u>	●		●					●						●
<u>J</u>								●						
<u>K</u>					●	●					●			
<u>L</u>				●	●	●		●						
<u>M</u>														●
<u>N</u>														
<u>P</u>										●				

U400