

Table of contents

User information	4	Optional hand-held transmitter	21
Storage and circulation of the manual	4	Safety information for the remote control	21
Description of the product type	4	Deleting the radio receiver memory	21
Target group of the manual	4	Programming the hand-held remote control	21
Other applicable documents	4	Deleting the hand-held transmitter from the radio receiver	21
Explanation of symbols	4	Deleting a channel from the radio receiver	21
Information regarding the depiction of text	4	Loss of a hand-held transmitter	21
Safety instructions	5	Operation and control	22
Warranty	5	Safety information on operation	22
Intended use	5	Operation with automatic closing function	22
Improper use	5	Single channel operation	23
Qualification of the personnel	5	Emergency release	23
Operator responsibilities	6	Control	24
Safety labeling on the barrier	6	Safety instructions	24
Personal safety equipment	6	Overview of the control system	24
Spare parts and accessories	6	Mains connection	25
Product description	7	Functions of the control system	25
Scope of supply	7	DIP switches	26
Dimensions	8	Regular testing and maintenance	27
Technical data	8	Troubleshooting	28
Type plate	8	Change the fuse.....	28
Transport/unloading/storage	9	Changing the spring	28
Transport	9	Changing lights	29
Unloading and in-house transport	9	Troubleshooting	29
Storage	9	Troubleshooting	30
Installation preparations	10	Fault - cause - elimination	30
Installation drawing	11	Disassembly and disposal	32
Creation of barrier foundation with supply connections	11	Safety information for disassembly	32
Creating the foundation of the support post	11	Storage after disassembly	32
Stationary command initiators	12	Description of the disassembly work	32
Safety measures	12	Disposal	33
Pedestrian traffic	12	EC Declaration of Conformity	34
Tools required	12	Entrance and exit scenarios	35
Installation	13	Drill template	39
Safety information for installation	13	Barrier handover report	41
Check the scope of supply	13	Brief instructions	43
Installation of the barrier housing	13		
Adapting the length of the boom	14		
Installation of the boom	14		
Installation of a LED boom	14		
Installation of the support post	14		
Aligning the position of the barrier	15		
Installation of accessories	15		
Connection to the power mains	17		
Initial operation	18		
Safety information for installation	18		
Check of the cable of the direct connector	18		
Adjustment of the spring unit	18		
Checking the direction of running	18		
Check of the path of the barrier	19		
Performing a control system reset and relearning the force values	20		
Adjusting the force tolerance	20		

User information

Storage and circulation of the manual

This manual must always be available at the site of installation and use of the barrier.

The operator must inform the personnel about the storage location of this manual and its supplementary manuals.

If the manual has become unreadable due to constant use, the operator must obtain a replacement from the manufacturer. To reorder the manual, contact the Customer Service department.

During the transfer or resale of the barrier to third parties, the following document must be passed on to the new owner:

- This manual
- The retrofitting and repair work documents
- Proof of regular testing
- Other applicable documents; see the "**User Information - Other Applicable Documents**" chapter.

Description of the product type

The ASB-6010A / ASB-5014A barrier has been constructed according to state-of-the-art technology and recognized technical regulations and is subject to the EC Machinery Directive (2006/42/EC). A Declaration of Conformity has been included in this manual.

This manual describes an industrially, commercially, and privately usable, powered barrier for vehicle traffic. The barrier is used to block and open entrances and exits from parking lots and other drives.

The ASB-6010A / ASB-5014A barrier is available in both right-closing and left-closing designs. A conversion is **not** possible.

Optionally available accessories are also described. The actual scope of supply may deviate.

Target group of the manual

The manual must be read and observed by everyone assigned with one of the following tasks:

- In-house transport
- Unpacking and installation
- Commissioning
- Adjustment
- Troubleshooting
- Testing
- Decommissioning
- Disassembly
- Storage
- Disposal

Other applicable documents

In addition to this manual, observe the following (technical) documents/regulations:

- National regulations regarding accident prevention
- National regulations regarding environmental protection
- Information regarding supervisory and reporting responsibilities, as well as company organization
- Recognized technical regulations for safe work

Explanation of symbols

The following symbols and signal words are used in this manual:



DANGER

Designates an immediate danger that leads to death or extremely severe injuries.



WARNING

Designate a possibly dangerous situation lead can lead to death, extremely severe injuries, or damage to the barrier and environment.



NOTE:

Designates more information and useful tips.



Refers to a part or machine component in a picture.

Warning symbols

If the source of danger can be specified more precisely, the following symbols are used together with the abovementioned signal words:



DANGER DUE TO ELECTRIC CURRENT!

In case of contact with live parts, current can flow through a body, possibly leading to electric shock, burns, or death.



DANGER OF TIPPING!

This symbol is used to label a danger of tipping during the transport and installation of the barrier.



DANGER DUE TO CLOSING BARRIER!

The non-observance of the rules of behavior lead to a dangerous situation that can lead to severe injuries.

Information regarding the depiction of text

- Stands for general safety instructions that must be observed!
- Stands for directions for an action with one or two instructions.
- 1. Stands for directions for an action with three or more instructions.
 - Stands for lists of the action.
 - ⇒ Stands for the results of the action.

Lists without a mandatory order are shown as a list with bullets (Level 1) and en-dashes (Level 2):

- List 1
 - Point A
 - Point B
- List 2

References to chapters and other documents are bolded, italicized, and placed in "**quotation marks**."

Safety instructions

Warranty

The warranty complies with statutory requirements. The contact person for warranties is the dealer.

The warranty is only valid in the country in which the barrier was purchased.

Batteries, fuses and lights are excluded from the warranty.

Intended use

Operate the barrier only in a perfect, traffic-safe state in a safety-conscious and risk-conscious manner.

The industrially, commercially, and privately usable ASB-6010A / ASB-5014A barrier is suited for the following applications:

- To block and open the entrances and exists of parking lots and other drives to which vehicles of all type have access
- For use with a boom from 1.5 meters to 6 meters
- In case of a boom length of 3 to 6 meters, either a floating support or a support post must be used
- Always install a support post for a LED boom of 3 to 5 meters
- Maximum 300 operating cycles per day
- Use with the required safety clearances to the surroundings
- Use with suitable safety devices and command initiators oriented on the expected vehicle traffic
- Use up to a maximum wind strength of 8 on the Beaufort scale (stormy wind).

Improper use

Every use not listed in the "**Intended Use**" chapter is considered to be improper. The operator of the barrier is solely responsible for resulting damage. This also applies to unauthorized changes, modifications, and programming of the barrier and its parts.

In particular, the following is not permitted:

- Use by pedestrians and cyclists (bicycles)
- Use at toll booths
- Use in parking garages
- Use with defective parts
- Use in enclosed spaces
- Use in explosive atmospheres or in environments with hazardous, flammable gases
- Installation of the barrier without a foundation or with a foundation that does not meet the requirements listed in the "**Installation Preparations - Creation of Barrier Foundation with Supply Connections**" chapter
- Use on foundations with an incline or slope
- Use of spare parts and accessories that have **not** been tested and released by SOMMER Antriebs- und Funktechnik GmbH
- Modification of the barrier or individual parts without the permission of SOMMER Antriebs- und Funktechnik GmbH
- Misuse of the barrier or individual parts for a similar area of application

Qualification of the personnel

People under the influence of drugs, alcohol, or medications that can influence their ability to react may not transport, install, operation, adjust, or disassemble the barrier.

Operator

The operator owns the barrier or has rented it.

In addition to the contractually regulation transfer of responsibilities to the operator, it is also responsible for the intended use of the barrier.

The operator is responsible for making sure its entire personnel fulfills all necessary physical and mental requirements for the tasks assigned to them.

Qualified transport personnel

The barrier is transported to the operator by a specialist dealer or by a haulage company commissioned by the specialist dealer.

Transport may not be performed by the operating personnel or by the operator. In-house transport is excepted here.

Qualified personnel for the foundation

The foundation of the barrier may be laid only by a trained expert. For this purpose, a required proof of static stability must be provided according to the local building code.

If necessary, consult a structural engineer.

Qualified personnel for installation, commissioning, and disassembly

The installation, commissioning, and disassembly of the barrier may only be performed by a trained expert.

The personnel must be familiar with the local accident prevention regulations.

Minors or trainees may perform this work only with the supervision of an experienced expert and with express permission of the operator.

Electricians

Work on the electrical system and live parts may be performed only by a trained electrician.

Work on the electrical system or live parts may not be performed by installation, commissioning, and disassembly personnel or the operator.

Qualified operating personnel

The qualified operating personnel are assigned the following responsibilities and tasks:

- Setting of the operating mode
- Emergency release of the barrier
- Elimination of malfunctions or the initiation of measures to eliminate malfunctions
- Testing of the barrier according to the intervals specified in the test plan

This person must be named by the operator and have taken part in training for the operation of the barrier provided by the operator.

Minors or trainees may perform this work only with the supervision of an experienced expert and with express permission of the operator.

Safety instructions

Users

The qualified operating personnel are assigned the following responsibilities and tasks:

- Opening and closing the barrier using the command initiators
- Use of the barrier with vehicles guided (control) by the users

Operator responsibilities

The operator of the barrier remains responsible for its use at all times unless otherwise agreed. This also applies when the barriers are used by third parties.

We would like to point out expressly that the ASB-6010A / ASB 5014 A barrier may only be used for vehicle traffic. People may not use the barrier. The operator must use suitable measures to guarantee a strict separation of vehicle and pedestrian traffic. Structural separations like pedestrian paths next to the lane must be supplemented with warnings and corresponding signs.

Using suitable measures, the opening and closing movements must be observed and monitored. The operation of the barrier installation without safety devices, visual supervision, or monitoring is not permitted.

In addition, the operator of the barrier must do the following:

- Assign the various tasks at the barrier to qualified, suitable, authorized personnel
- Provably train the operating personnel in the proper operation of the barrier and the effect of all safety devices. The training or instruction of the personnel must be confirmed in writing!
- Damage and faulty parts must be eliminated by suitable qualified personnel immediately.
- Commission experts with tests at regular intervals and keep a record of these tests
- Document retrofitting work
- Make sure that the barrier is operated only in a technically perfect condition
- Equip the personnel with suitable protective work clothes
- Installation of signal boards, notices, or structures (railings) so that pedestrians are sufficiently warned and do not walk through the barrier installation
- Design the entrance widths for vehicles in such a way that wider, longer, and high vehicles can enter comfortably without damaging the installation.



NOTE:

See the "Installation Preparations" chapter. The necessary preparations and responsibilities are listed there.

Safety labeling on the barrier

The danger zone of the barrier is labeled with a warning sign. In addition, reflectors can be attached to the boom.





Before the operation of the barrier, the operator and personnel must be familiarized with the position and meaning of the warning sign on the barrier.

All warning signs and reflectors attached in and to the barrier must always be easily visible and undamaged.

Damaged or missing warning signs and reflectors must be replaced by the operator immediately.

Personal safety equipment

The following table shows which protective equipment must be worn for the special work requirements and which safety measures must be taken.

					
Transport	X	X	X		X
Installation		X	X	X	X
Commissioning					X
Troubleshooting			X		X
Disassembly		X	X	X	X
Disposal	X	X	X		X

Spare parts and accessories

Use only original spare parts or the spare parts of other manufacturers that have been approved by SOMMER Antriebs- und Funktechnik GmbH.

If safety-relevant parts are replaced, their function must be checked afterwards.

Use only accessories approved by SOMMER Antriebs- und Funktechnik GmbH. The use of accessories can change the work with the barrier. In addition, observe the instructions for work and safety during the use of accessories.

Product description

Scope of supply

Standard scope of supply

The actual scope of supply may vary depending on the design of the barrier. The standard scope of supply contains the following goods:

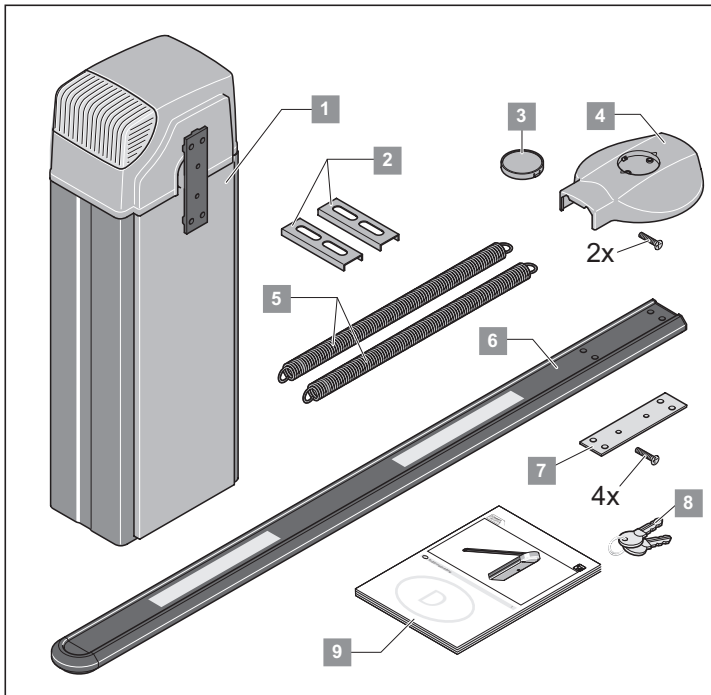

Item	Quantity	Description
1	1	Barrier housing - left-closing or right-closing design
2	2	U-profiles
3	1	Faceplate of the boom cover
4	1	Boom cover with 2 screws
5	2	Springs - 2 factory-installed
6	1	Boom
7	1	Shim plate with 4 screws
8	2	Keys of the barrier housing
9	1	Installation and Operating Instructions



NOTE:

The detailed list of the scope of supply can be found on the order form.

Available accessories

A number of accessories are available for the barrier. The accessories can be reordered at any time from SOMMER Antriebs- und Funktechnik GmbH.

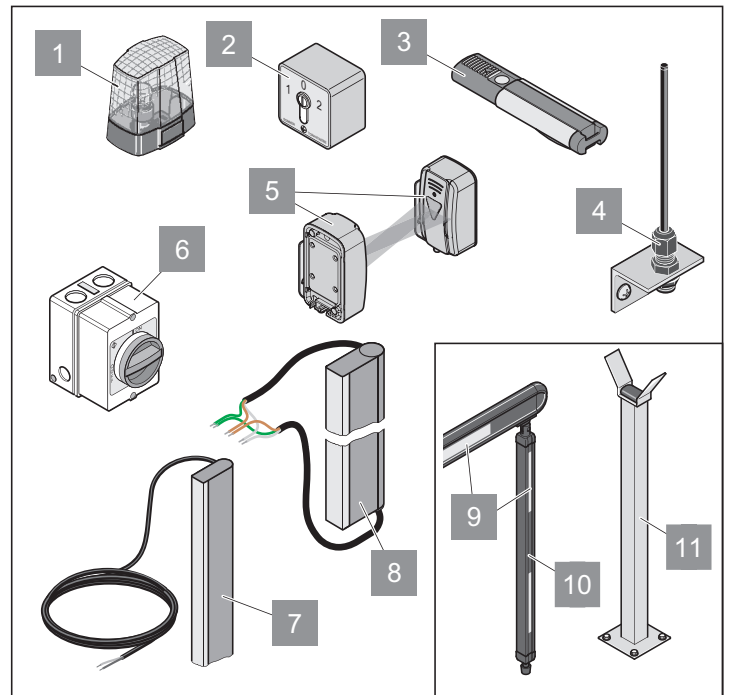

1 Warning light

The users of the barrier are warned of an opening or closing barrier by the warning light.

2 Key switch

The barrier opens or closes when the key switch is activated.

3 Hand-held transmitter

Using the hand-held transmitter, the barrier is opened or closed by radio signal.

4 External antenna

The external antenna extends the reception range for radio signals.

5 Photo eye

The photo eye detects objects and sends a signal to the control system when something is detected. A closing of the barrier can be prevented, for example, if the photo eye is monitoring the closing range.

6 Main switch

The lockable main switch (all-pole line disconnecter according to EN 12453) de-energizes the barrier on all poles.

7 8.2 kOhm safety contact strip (electrical)



NOTE:

Either an 8.2 kOhm safety contact strip or an optical safety contact strip (OSE in the following) can be connected!
A connection of both safety devices is not possible!

If the 8.2 kOhm safety contact strip attached to the boom hits an obstacle during the closing procedure, the barrier stops and opens completely.

The C-rail required for installation is included.

Product description

8 Optical safety contact strip - OSE system



NOTE:

Either an 8.2 kOhm safety contact strip or an optical safety contact strip (OSE in the following) can be connected!
A connection of both safety devices is not possible!

If the 8.2 kOhm safety contact strip attached to the boom hits an obstacle during the closing procedure, the barrier stops and opens completely.

The C-rail required for installation must be purchased separately.

9 Reflectors

Reflectors attached to the boom increase the visibility of the boom in the dark.

10 Floating support (up to a maximum boom length of 5 meters)

In case of a boom length of 3 to 5 meters, either a floating support or a support post must be installed. In case of a boom length of more than 5 meters, a support post must be installed.

11 Support post

In case of a boom length of 3 to 5 meters, either a floating support or a support post must be installed. In case of a boom length of more than 5 meters, a support post must be installed.

12 Loop evaluation

If induction loops are present on-site for the opening or closing of the barrier, their signals can be processed using loop evaluation.

Dimensions

All dimensions are in millimeters.

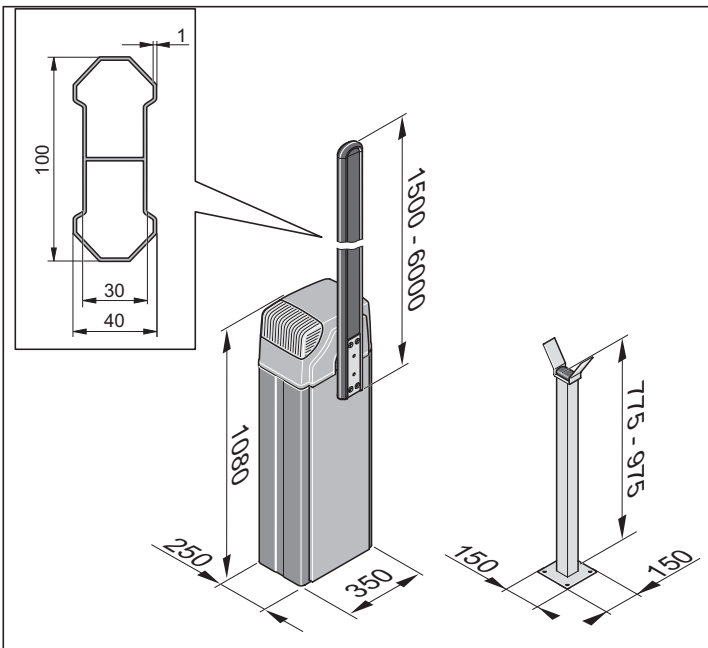

Technical data

Weight without the boom	40 kg
Weight with the boom 6 m	6 kg
Maximum opening width	5.55 m
Weight of 5 m LED boom	6 kg
Max. opening width of LED boom	4.55 m
Opening time	Max. 7 sec.
Closing time	Max. 7 sec.
Voltage supply	230 V; 50 Hz <input type="checkbox"/>
Motor	24 V DC
Power consumption in normal operation	80 W
Power consumption in standby	Max. 2 W
Dimensions without the boom	H 1080 mm x W 350 mm x D 250 mm
Dimensions of boom	5/6 m, can be shortened to 1.5 m
Protection type	IP 44
Temperature range	- 20 °C to + 60 °C
Maximum wind strength according to Beaufort scale	8 (stormy wind), corresponds to 20.6 m/s or 74 kph
Permitted cycles	Max. 300 cycles/day

Type plate

The type plate is attached to the inside of the housing.

The following data is on the type plate:

- Company name and complete address of the manufacturer
- Designation of the machine
- CE mark
- Type designation and serial number
- Manufacturing date (month/year) of the barrier

Transport/unloading/storage

Transport

The barrier is transported to the operator by a specialist dealer or by a haulage company commissioned by the specialist dealer.

After the contractually regulated handover of all responsibility to the operator, the operator must make sure that the barrier is safely and properly transported during transport.

The following information regarding transport absolutely must be observed:

- Do not stack the packaging units on top of each other.
- Transport the packaging units in the position specified on the packaging.
- Even during transport, observe the ambient conditions (temperature, humidity, etc.) required by the manufacturer.
- Always make sure that the barrier is transported without impacts and jolts.
- Always secure the loads to be transported against falling, tipping over, and damage.

Unloading and in-house transport



WARNING

During this work, dangers may arise, for example, due to uneven surfaces, sharp edges, or the use of operating materials and adjuvants.

Body parts may be injured.

- **Wear suited, closely fitting protective work clothes (safety helmet, safety shoes, and safety gloves at minimum). Do not wear long hair loosely.**



DANGER

Falling load!

During unloading, the load may fall and cause severe or deadly injuries.

- **Use lifting equipment designed for the weight of the load.**
- **Never walk under suspended loads.**

Check packaging units for externally recognizable transport damage or other damages. In case of damage, have it confirmed by the haulage company and inform SOMMER Antriebs- und Funktechnik GmbH immediately in writing.

After unloading, store the barrier until setup. For this purpose, the operator of the barrier might have to transport the barrier for the place of unloading to the storage location.

In the process, observe the following information regarding unloading and intermediate transport:

- For unloading and in-house transport, **at least two people** are required.
- Only use suitable, tested, and standardized lifting equipment (fork lift truck, mobile crane, overhead crane) and means of suspension (slings, lifting belts, sling ropes, chains).
- When selecting the lifting equipment and means of suspension, always take the maximum load-bearing capacities into consideration.
- Always make sure that the barrier is unloaded and transported without impacts and jolts.
- Do not stack the packaging units on top of each other.
- After unloading, do **not** remove the packaging materials or transport safety devices.

Storage



WARNING

The drive and other subassemblies of the barrier may be damaged by incorrect storage.

Irreparable damage to the barrier may be the result.

- **Observe the following storage conditions at first delivery and intermediate storage!**

The packaging units are packed in a plastic film for transport that protects them against environmental influences.

- Do not remove or damage this plastic film. If necessary, additionally cover the subassemblies.
- Store the packaging units in enclosed, dry rooms so that they are protected against moisture and UV radiation.
- Store the packaging units at a storage temperature from -20 °C to $+60\text{ °C}$.
- Store the packaging units in the position specified on the packaging.
- Do not stack the packaging units on top of each other.
- Leave room for unhindered passage.

Installation preparations

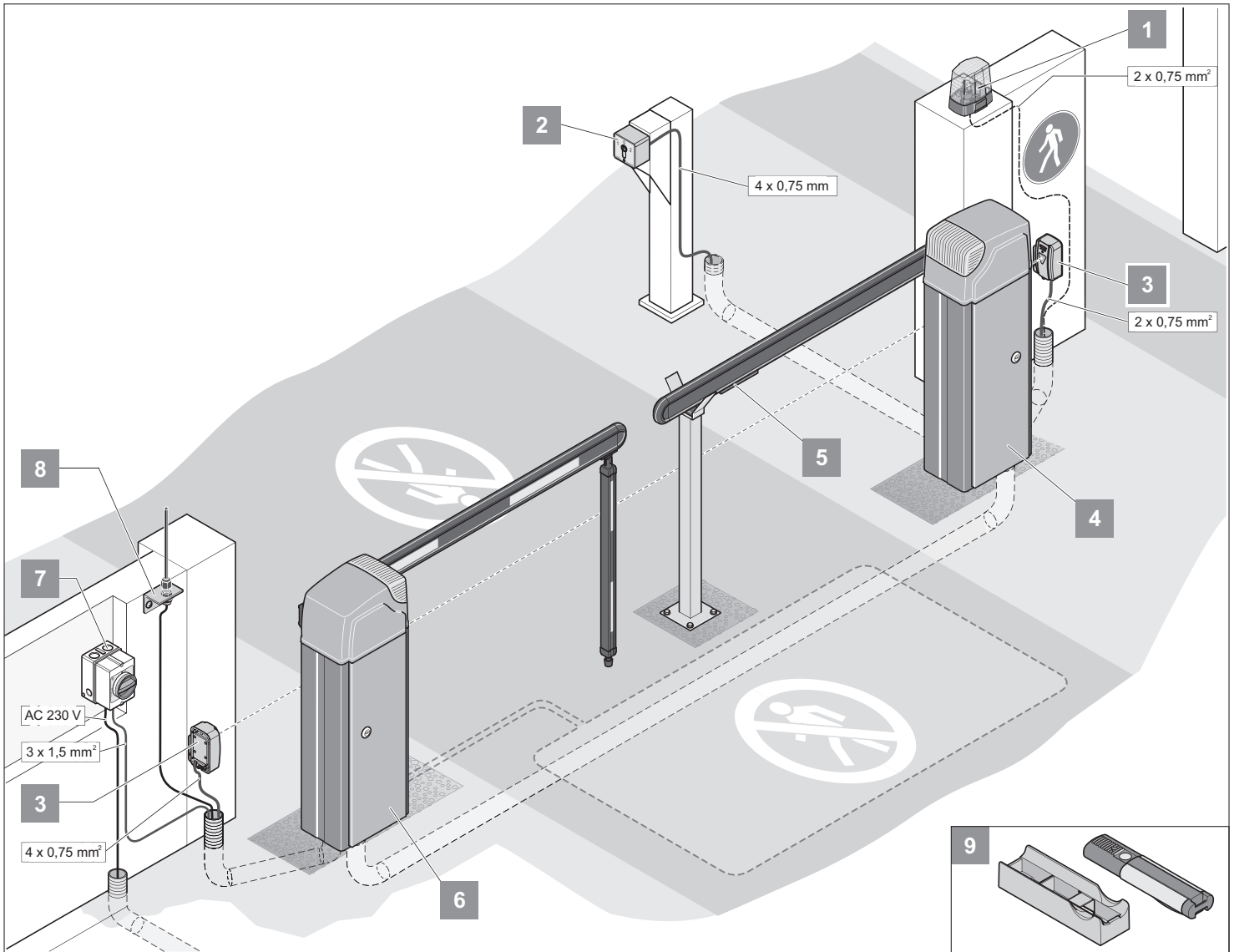

A possible installation scenario is shown here as an example.

Determine the position of the accessories before installation together with the operator.



NOTE!

Further possible command initiators are Telecody and wireless indoor switches. In the case of Telecody or the wireless indoor switches, no connecting line must be installed for operation. Ask your specialist dealer.

1	Warning light DC 24 V
2	Key switch
3	Photo eye
4	Left-closing barrier
5	8.2 kOhm safety contact strip or OSE system
6	Right-closing barrier
7	Main switch (lockable)
8	External antenna (incl. 10 m cable)
9	Hand-held transmitter with car/wall holder

Before the installation of the barrier, organizational and on-site preparations must be made.

Observe the following information for the preparation of installation:

- The entire length of the boom is not equal to the effective opening width.
- For a boom length of **more than 3 meters**, a floating support or support post is required. Use floating supports only up to a **maximum boom length of 5 meters**.
- The barrier house and tip of the boom must have a safety distance of **at least 500 mm** to the next stationary obstacle (building, wall, fence, etc).
- Implement the mains connection according to EN 12453 (all-pole line disconnecter). For this purpose, install a lockable main switch (all-pole deactivation).
- Operate barriers only with a permanently laid line secured with a fuse (16 A, slow-acting). The mains cable connected in the delivery state is not approved for constant or outdoor operation.
- A **minimum distance of 5 meters** must be observed between the range of movement of the barrier and free lines/boom.
- Provide empty ducts in the foundation of the barrier and throughout the installation site for the cables of the mains supply line and the accessories (photo eye, warning light, key switch, etc.).

Installation preparations

Installation drawing

Using the overview illustration, the position of the foundation, the length of the boom, and, if necessary, the position of the support post can be calculated.

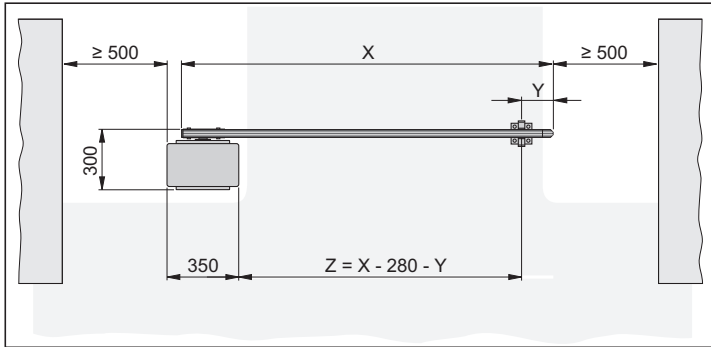

X = Boom length (from 1500 mm to 6000 mm)

Y = Distance from the tip of the boom to the center of the support post or floating support. Minimum of 150 mm, maximum of 300 mm

Z = Opening width of the barrier - drive-through width

Sample calculation:

Calculation of the boom length (X) at:

Opening width of the barrier (Z) = 3500 mm

Distance between the tip of the barrier and the center of the support post (Y) = 200 mm

$X = Z + Y + 280$ mm

$X = 3500$ mm + 200 mm + 280 mm

X = 3980 mm

Creation of barrier foundation with supply connections

For the proper operation of the barrier, the barrier housing must stand securely.

The following table shows the minimum foundation size and the foundation size recommended by SOMMER Antriebs- und Funktechnik GmbH. According to the danger of frost, the depth of the foundation (D) must be adapted in a frost-proof manner so that the ground cannot lift.

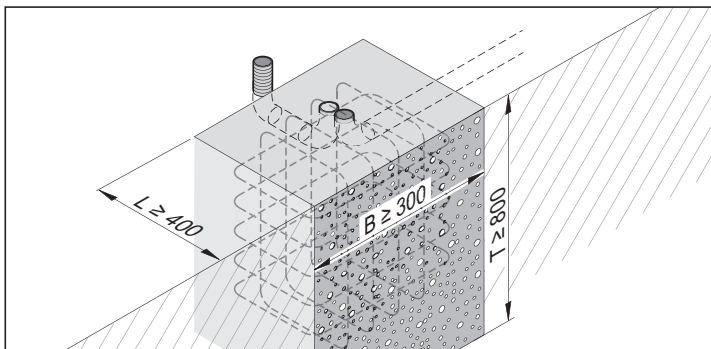

	D	W	L
Minimum size	Frost-proof! In Germany, 800 mm	300 mm	400 mm
Recommended	1,000 mm	400 mm	400 mm

Conduct all required empty ducts and lines from the middle of the foundation. When selecting empty duct, take all lines to be laid into consideration.

This may be as follows:

- Power supply line
- Connecting line for the photo eye/induction loop
- Connecting line for the stationary command initiators
- Connecting line for accessories like the warning light, external antenna, etc.



WARNING

Never lay the power supply line in the same duct as the connecting lines.

Interference in the control system may result.

- **Use different empty ducts for the power supply line and the connecting lines.**

Only use lines/cables suitable for the outdoors (cold resistance, UV-resistance).

The surface of the foundation must be even and absolutely horizontal to the lane (smoothened) so that the barrier housing can be set up evenly.

Use concrete with the following strength class:

- EN 206 C25/30 XC4, XF1, XA1 (25-30 N/mm²)

The foundation must be massive and steel-reinforced.

The barrier housing is attached using heavy-duty anchors (not included in delivery).

Minimum size of the heavy-duty anchor M10x120 or M12x125.



NOTE:

For more information regarding heavy-duty anchors, contact your specialist dealer.

Creating the foundation of the support post

A stable foundation is required for the installation of the support post.

The minimum size for the foundation is specified in the following table. According to the danger of frost, the depth of the foundation (D) must be adapted in a frost-proof manner so that the ground cannot lift.

D	W	L
Frost-proof! In Germany, 800 mm	200 mm	200 mm

The surface of the foundation must be even and absolutely horizontal to the lane (smoothened) so that the barrier housing can be set up evenly.

Use concrete with the following strength class:

- EN 206 C25/30 XC4, XF1, XA1 (25-30 N/mm²)

The barrier housing is attached using heavy-duty anchors (not included in delivery).

Minimum size of the heavy-duty anchor M8x75 or M10x85.



NOTE:

For more information regarding heavy-duty anchors, contact your specialist dealer.

Installation preparations

Stationary command initiators

The stationary command initiators (key switch, pushbutton, etc.) must be placed in such a way that

- They can be reached easily from any vehicle.
- The user is not in the range of movement of the barrier.
- The user has direct visual contact with the barrier during actuation.

Safety measures

For the safe operation of the barrier, the operator **must** install the necessary safety devices. Using suitable measures, the opening and closing movements must be monitored.

The following are suited to this purpose:

- Photo eyes
- Induction loops
- 8.2 kOhm safety contact strip or OSE system



NOTE:

Up to two safety devices can be connected to the control system! A safety device must always be connected as an NC contact so that safety is always guaranteed in case of a defect.

For example, various safety device scenarios are shown in the "**Appendix - Entrance and Exit Scenarios**" chapter.

Pedestrian traffic

The ASB-6010A / ASB-5014A barrier may only be used for vehicle traffic. People may not use the barrier.

The operator must use suitable measures to guarantee a strict separation of vehicle and pedestrian traffic. Structural separations like pedestrian paths next to the lane must be supplemented with warnings and corresponding signs.

Tools required

The following tools must be available for proper installation:

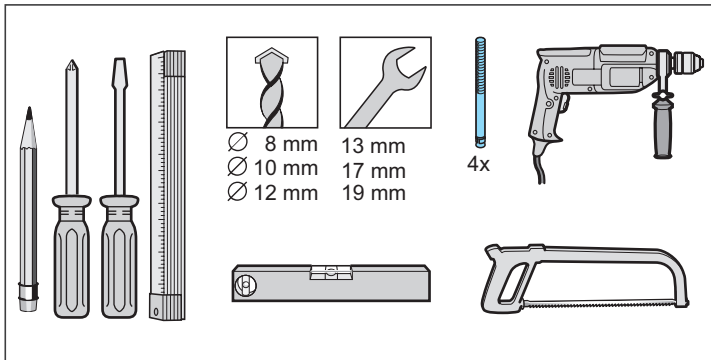

Installation

Safety information for installation

- Perform installation only up to a maximum wind strength of 3 on the Beaufort scale (light wind).
- **At least two people** are required for the entire installation.
- For installation work performed above body height, used suitable, tested, and stable climbing aids. Never use the barrier or parts of the barrier as climbing aids.
- Check all screws and terminals in and on the barrier for a firm seat and tighten them, if necessary.
- The installation of the barrier and all work on the electric system may only be performed by the personnel described in the "**Safety Information - Qualification of the Personnel**" chapter.



DANGER OF TIPPING!

The barrier may tip during installation and in-house transport. People can be injured and the barrier can be damaged.

- Transport and installation may be performed only with two people and suitable transport equipment.

Check the scope of supply

Remove the barrier and all accessories from the packaging at the installation site. No sharp objects may be used to open the packaging since parts could otherwise be damaged.

Check the delivery for completeness (see the "**Product Description - Scope of Delivery**" chapter and order form).

In case of an incomplete delivery, contact your specialist dealer or SOMMER Antriebs- und Funktechnik GmbH.

Dispose of the packaging according to locally applicable regulations.

Installation of the barrier housing

1. Pull the cables into the empty ducts and label them for later allocation.

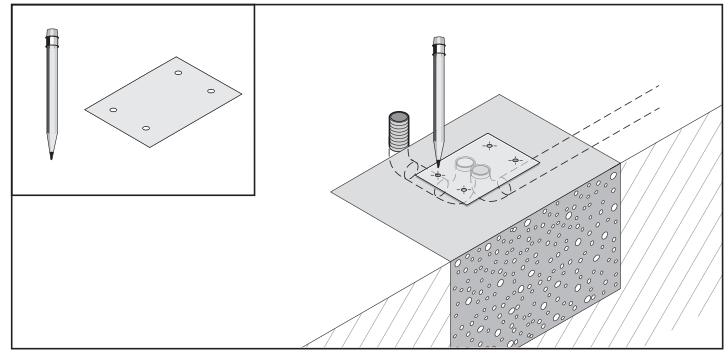

2. Remove the drill template from this manual (see the "**Appendix - Drill Template**" chapter), place it on the foundation, and draw in four holes.

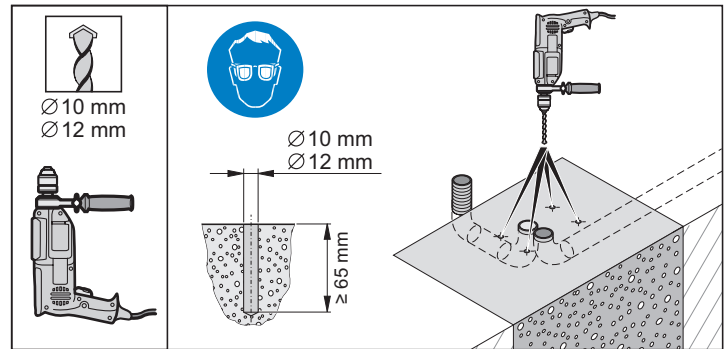

3. Drill four holes \varnothing 10 or \varnothing 12 mm at least 65 mm deep.

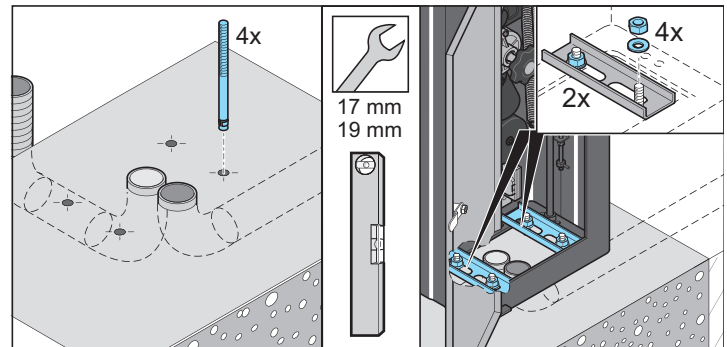

4. Blow out holes with compressed air.



NOTE:

Only use permissible fastening materials. For the recommended heavy-duty anchors, see the "**Installation Preparations - Creation of Barrier Foundation with Supply Connections**" chapter.

5. Insert four heavy-duty anchors into the holes.
6. Put the barrier housing into place and open the door.



NOTE:

Remove the control system and put it aside. Do not reinstall the control system until after the connection to the power mains.

7. Insert both U-profiles.
8. Align the barrier housing or U-profiles. Put four washers into place and tighten four nuts. With the spirit level, check the horizontal alignment of the barrier and correct it if necessary.
9. Close the barrier house.

Installation

Adapting the length of the boom



NOTE:
The entire length of the boom is not equal to the effective opening width!



NOTE:
When using a LED boom do not damage cables and LED bars when sawing

To calculate the required length of the boom, see the "*Installation Preparations - Installation Drawing/Sample Calculation*" chapter.

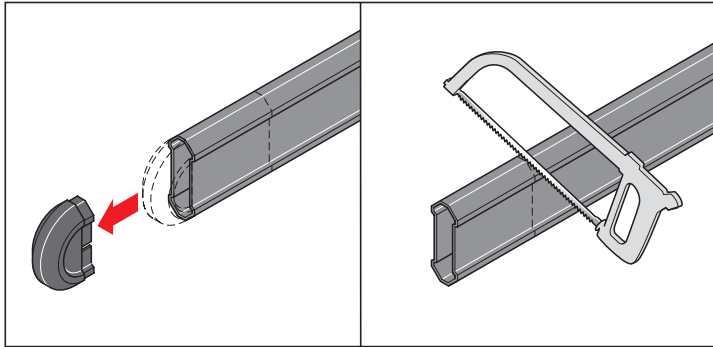

1. Remove the cover from the tip of the boom.

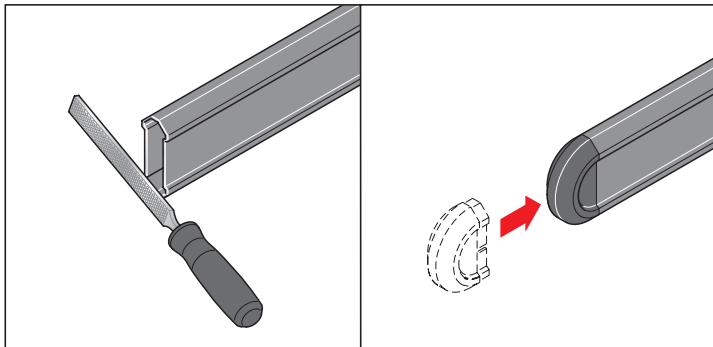

2. Cut the boom to the desired length and deburr it if necessary.
3. Place the cover onto the tip of the boom.

Installation of the boom



NOTE:
When using a floating support, install it before installing the boom. See the "*Installation - Installation of the Floating Support*" chapter.

1. The boom is attached in the vertical opening position.

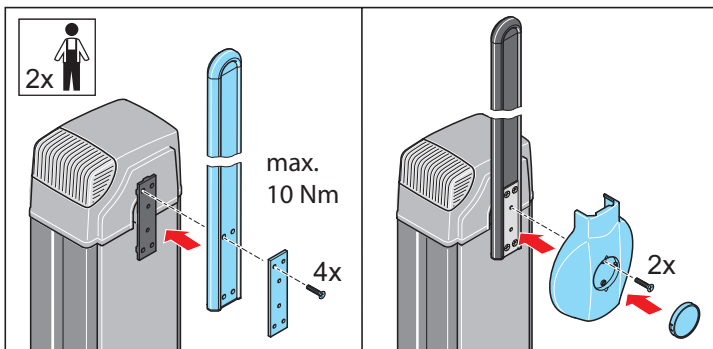

2. Place the boom onto the boom holder, put a shim plate on it, and fasten with four screws.
3. Install the cover with two screws and put the faceplate into place.

Installation of a LED boom



NOTE:
A floating support cannot be used with the LED boom!
Use a supporting post for a boom length between 3 and 5 m

1. The boom is attached in the vertical opening position.

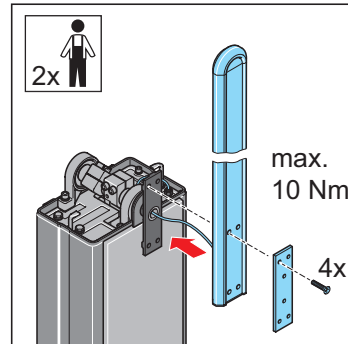

2. Insert the cables of the LED boom into the hold in the boom holder.
3. Attach the boom to the boom holder, attach the washer and fix it with 4 screws.

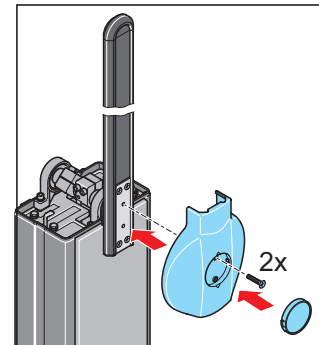

4. Install the cover with two screws and put the faceplate into place.

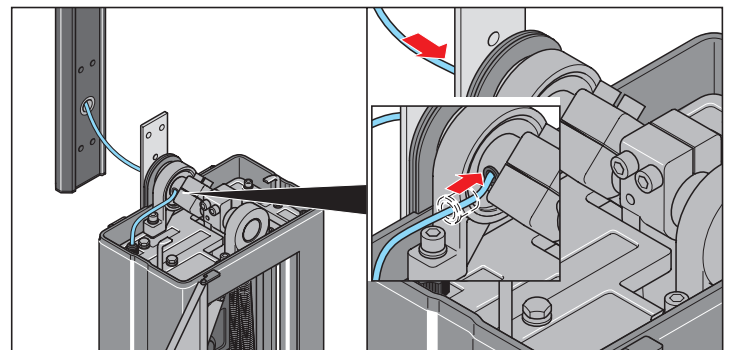

5. Insert cables into housing from shaft. Install the rubber grommet correctly.
6. Insert cables inside the barrier housing through the base plate cable gland.

Installation

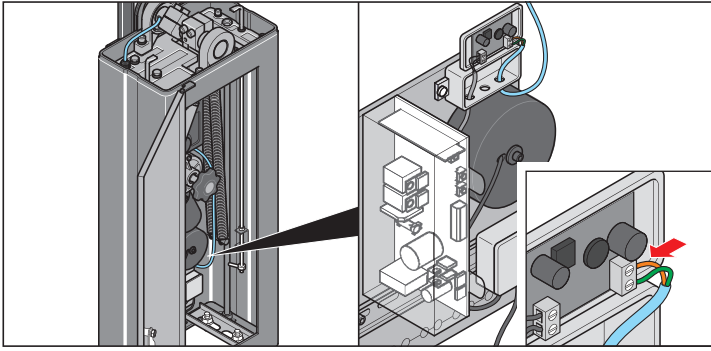

7. Insert cables into the terminal box and connect correctly for the polarity of the DCDC converter.

Installation of the support post

1. To calculate the required length of the support post, see the "*Installation Preparations - Installation Drawing/Sample Calculation*" chapter.

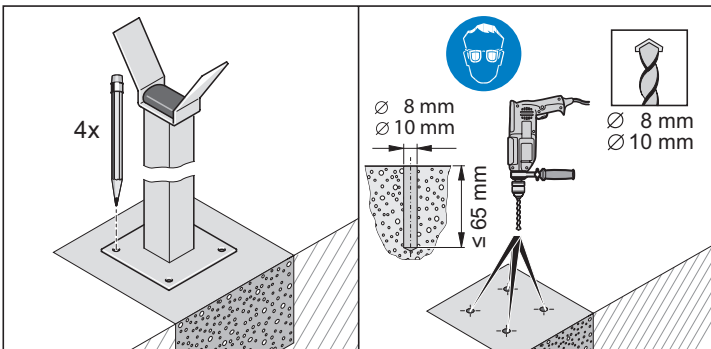

2. Put the support post into place and draw in four holes.
3. Drill four holes $\varnothing 8$ or $\varnothing 10$ mm at least 65 mm deep.
4. Blow out holes with compressed air.



NOTE:

Only use permissible fastening materials. For the recommended heavy-duty anchors, see the "*Installation Preparations - Creation of Support Post Foundation*" chapter.

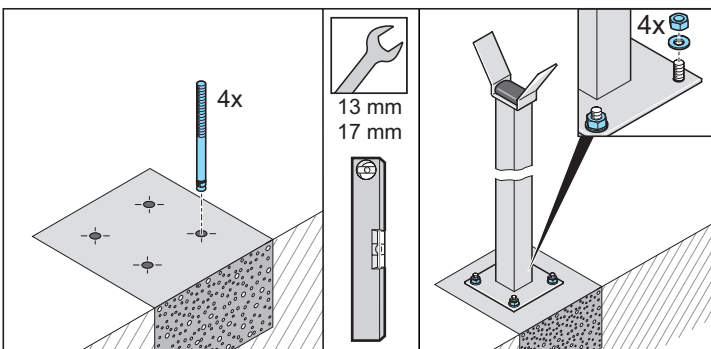

5. Insert the heavy-duty anchors into the holes.
6. Put the support post into place. Put four washers into place and tighten four nuts. With the spirit level, check the horizontal alignment of the support post and correct it if necessary.

Aligning the position of the barrier

1. Open the emergency release (see the "*Operation and Control - Emergency Release*" chapter) and close the barrier.

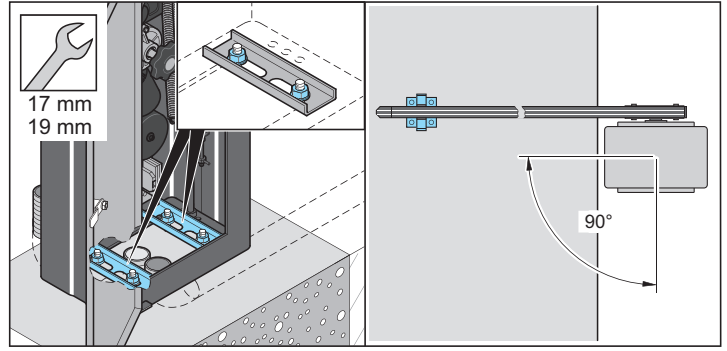

2. Open the barrier housing and loosen the four nuts so that the barrier can be aligned.
3. Align the barrier in such a way that it is parallel to the lane and the boom is lying on the support post.

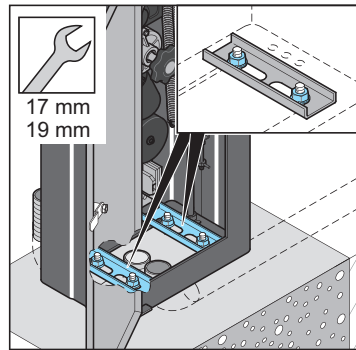

4. Tighten four nuts according to the requirements of the heavy-duty anchor manufacturer.

Installation of accessories

- All devices to be connected externally must have a safe isolation of the contacts from the mains voltage supply according to EC 60364-4-41.
- To install the accessories, the barrier and all lines must be de-energized and secured against reactivation.

For connection to the direct connector and the adjustment of the DIP switches, see the "*Control System*" chapter.

Installation of the key switch

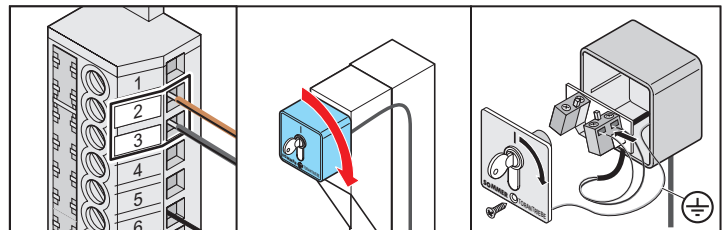

- Install the key switch and connect it to the direct connector.
- Never lay the cable of the key switch along a power lines as this could cause interference in the control system.

Installation

Installation of the warning light

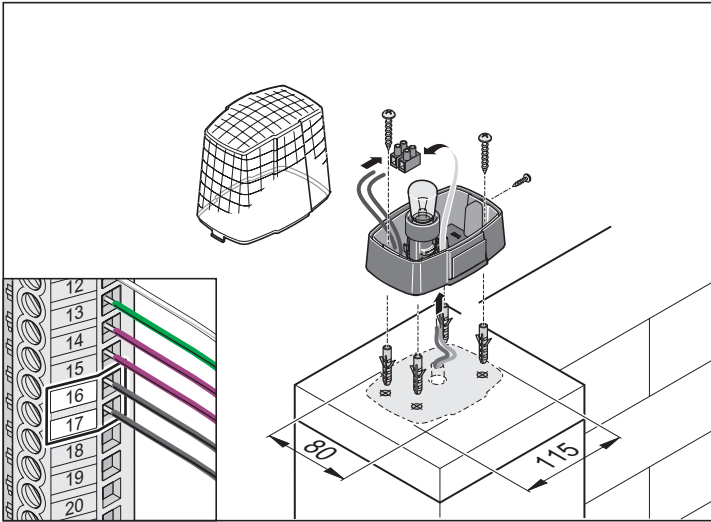

- Install the warning light and connect it to the direct connector.

Installation of the photo eye

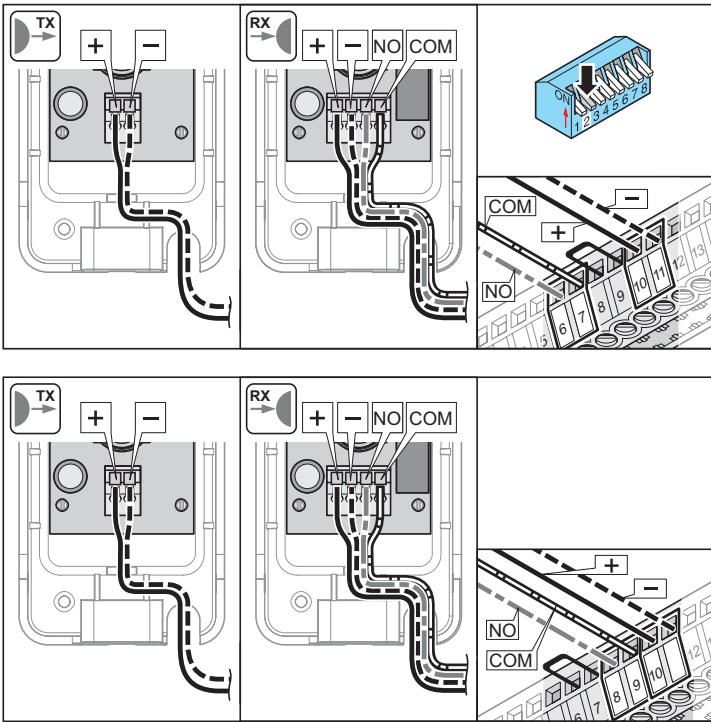

- Install the photo eye and connect it to the direct connector.

Installation of the main switch



NOTE:

The lockable main switch (all-pole line disconnecter according to EN 12453) de-energizes the barrier on all poles.



DANGER!

In case of direct or indirect contact with live parts, current could flow through the body.

Electrical shock, burns, or death may result.

- Before performing wiring work, make sure that the lines are de-energized. During the wiring work, make sure that the lines remain de-energized (e.g. prevent reactivation).
- The connection to the power mains may be performed only by the personnel described in the "Safety Information - Qualification of the Personnel" chapter.

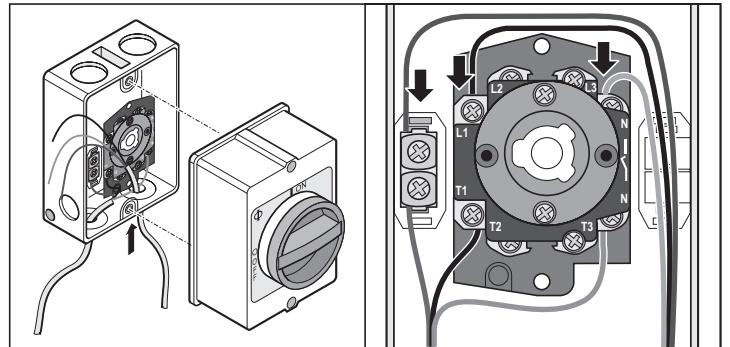
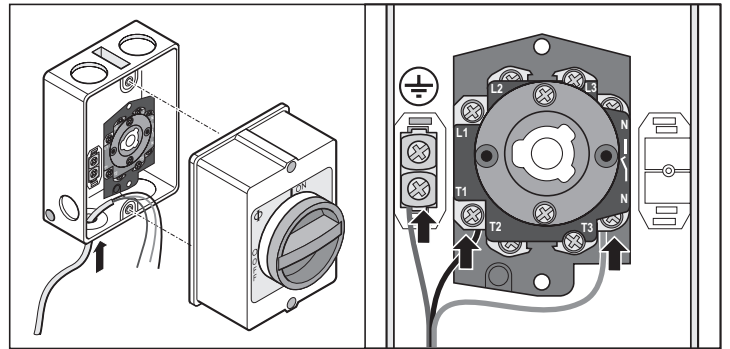

- Connect the mains supply line of the barrier to the main switch.
- Connect the external mains supply line to the main switch.

Installation

Installation of the external antenna



NOTE:
For booms without lighting only!

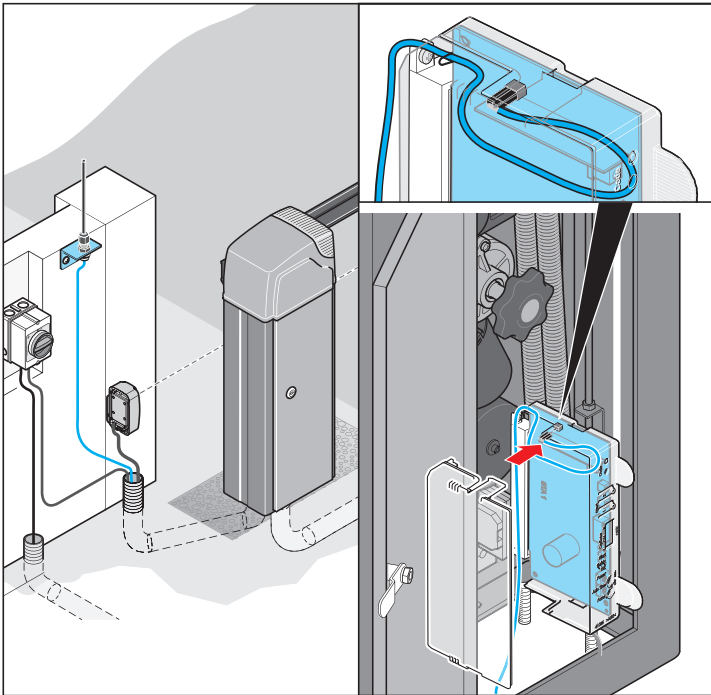

- Install the external antenna and connect it to the control system.

Installation of the 8.2 kOhm safety contact strip



NOTE:
Either an 8.2 kOhm safety contact strip or an OSE system can be connected! A connection of both safety devices is not possible!

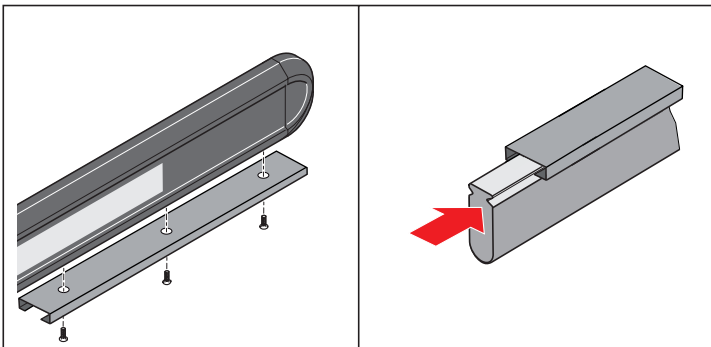

1. Rivet or screw on the C-profile of the 8.2 kOhm safety contact strip to the tip of the boom (observe the distance to the support post!).
2. Push the 8.2 kOhm safety contact strip into the C-profile.

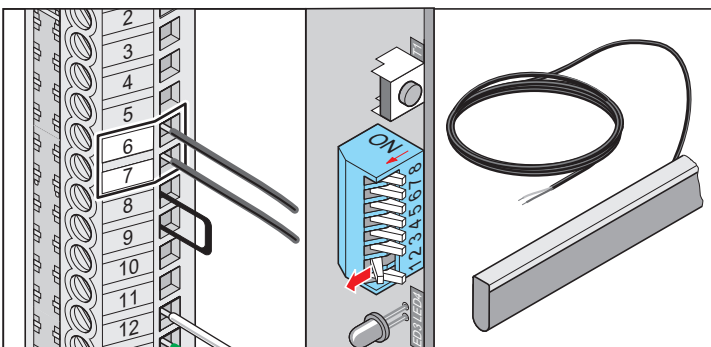

3. Connect the 8.2 kOhm safety contact strip to the direct connector.

Installation of the OSE system



NOTE:
For booms without lighting only!



NOTE:
Either an 8.2 kOhm safety contact strip or an OSE system can be connected! A connection of both safety devices is not possible!

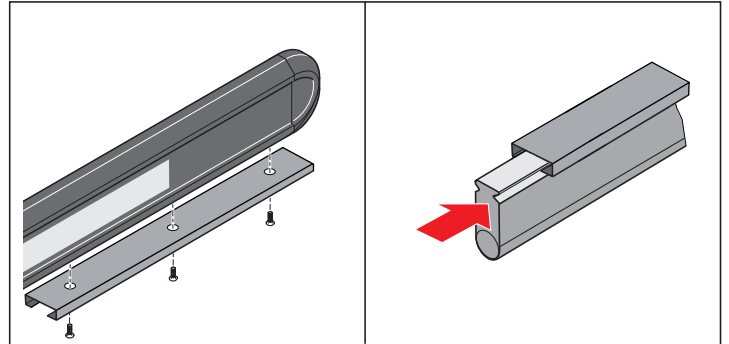

1. Rivet or screw on the C-profile of the OSE system to the tip of the boom (observe the distance to the support post!).
2. Push the OSE system into the C-profile.

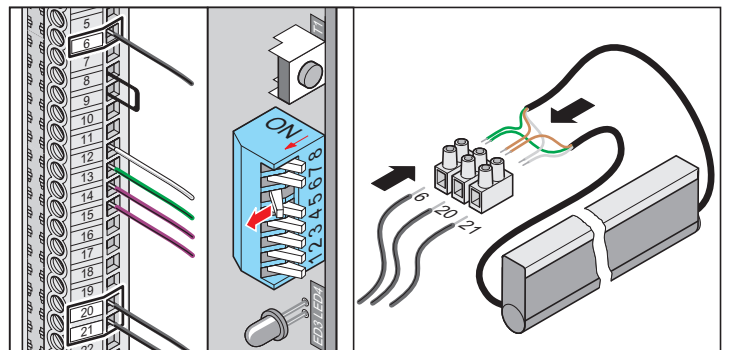

3. Connect the OSE system to the direct connector.

Terminal 6	Green cable from the OSE system
Terminal 20	Brown cable from the OSE system
Terminal 21	White cable from the OSE system

Installation of the floating support

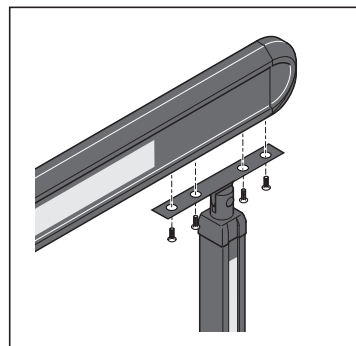

1. To calculate the position of the floating support, see the "**Installation Preparations - Installation Drawing/Sample Calculation**" chapter.
2. Rivet or screw the floating support to the tip of the beam.
3. Close the barrier and check the distance of the floating support to the ground. When closed, the distance must amount to **about 2 cm**. If necessary, correct the lower end positions of the barrier; see the "**Commissioning - Adjusting the Path of the Barrier via the End Positions**" chapter.

Connection to the power mains

- The voltage of the power source must correspond with the voltage listed on the type plate.
- Check the mains supply line according to the valid regulations at the installation site and on the customer's side. Before the connection of the barrier, perform an electrical test according to the valid regulations.
- If there is a danger that the mains voltage will have larger fluctuations, even for a brief period of time, the barrier must be supplied via a voltage stabilizer.
- Operate barriers only with a permanently laid line secured with a fuse (16 A, slow-acting).
- Implement the mains connection according to EN 12453 (all-pole line disconnector). For this purpose, install a lockable main switch (all-pole deactivation).



DANGER!

In case of direct or indirect contact with live parts, current could flow through the body.

Electrical shock, burns, or death may result.

- Before performing wiring work, make sure that the lines are de-energized. During the wiring work, make sure that the lines remain de-energized (e.g. prevent reactivation).
- The connection to the power mains may be performed only by the personnel described in the "Safety Information - Qualification of the Personnel" chapter.

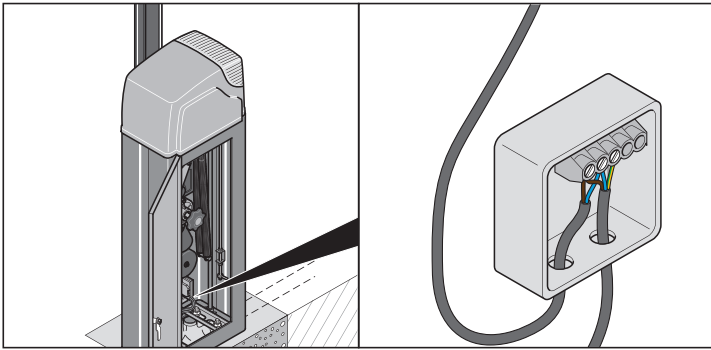

1. Open the door of the barrier housing.
2. Disconnect the mains supply line:



INFO:

A protective ground must not be connected!

Terminal	Cable color	Name
Brown	Brown	(L) AC 220 - 240 Volt
Blue	Blue	(N)
--	Green/yellow	PE (connect to mains side only)

3. Plug in the control system. Check for the correct polarity (protection against incorrect insertion: yellow plug between terminals 11 + 12)!

Initial operation

Safety information for installation

The barrier may not be commissioned until:

- The barrier is firmly and safety anchored in the foundation.
- All required monitoring units (for example, photo eyes) are correctly connected.
- All accident prevention measures are performed.
- All safety provisions are observed.

Check of the cable of the direct connector

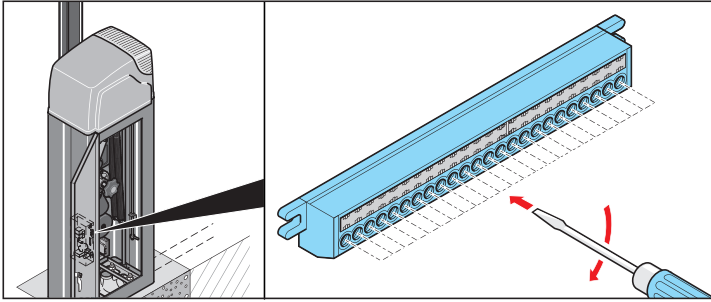

1. De-energize the barrier and secure it against reactivation.
2. Open the door of the barrier housing.
3. Check all the cables on the direct connector (1) for a firm seat and tighten the terminals, if necessary.

Adjustment of the spring unit

- **At least two people** are required for the adjustment of the spring unit.



WARNING

The adjustment of the spring unit is safety-relevant and must be performed by qualified personnel with utmost care.

If the adjustment of the spring unit is impermissibly high, people could be injured and objects damaged.

- Adjust the spring unit as described in the following so that you can detect obstacles quickly and safely.

The barriers are delivered without the adjustment of the spring unit. The required spring force depends on the respectively installed boom and the accessories mounted on it.

The barrier works correctly only if the weight of the boom is compensated by the tensile force of the springs; for this purpose:

1. De-energize the barrier and secure it against reactivation.

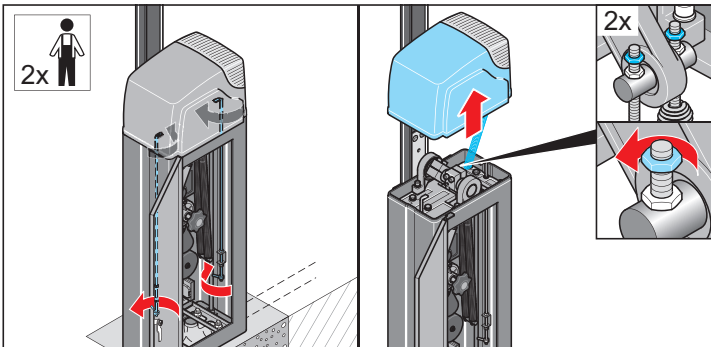

2. Open the door of the barrier housing.
3. Release the locking mechanism of the cover.
4. Remove the top cover of the barrier and disconnect the cover cable at the barrier housing.

5. Release the lock nuts of both springs.
6. Open the emergency release of the barrier; see the "**Operation and Control - Emergency Release**" chapter.

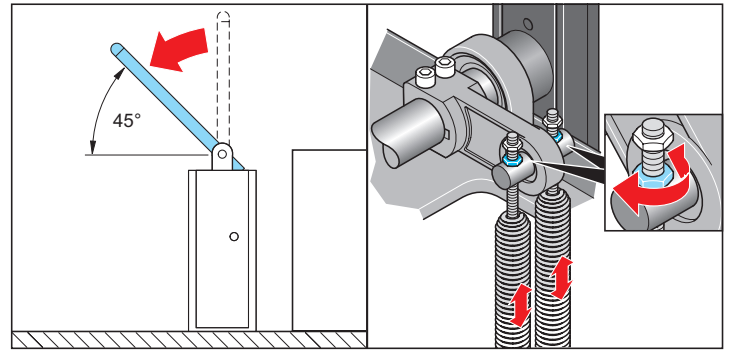

7. Bring the boom into a 45° angle with the emergency release button and hold it there.
8. Adjust both nuts of the springs in such a way that the boom remains at a 45° angle when released.

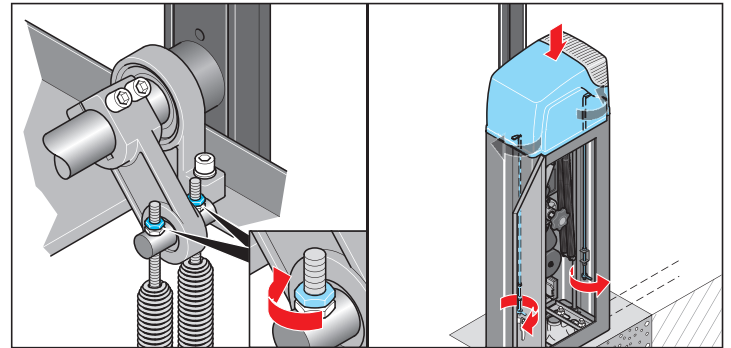

9. Release the lock nuts of both springs.
10. Plug in the barrier cover cable at the housing and plug in the cover
11. Put the cover of the barrier into place and lock it.



NOTE:

If changes are made later on the boom, the spring force must be readjusted. This is necessary when shortening the boom, mounting accessories on the boom, or exchanging the boom for a longer or shorter boom.

Checking the direction of running

1. Connect the power supply of the barrier.

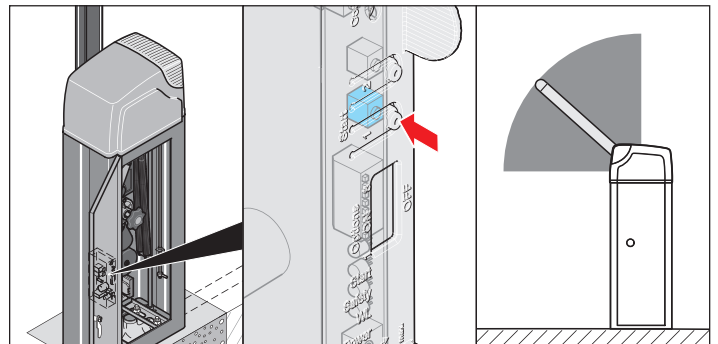

2. Press the button (1).
⇒ The barrier opens until the BARRIER OPEN end position is reached or until it is opened.
3. Press the button (1).
⇒ The barrier closes until the BARRIER CLOSED end position is reached.

Initial operation

Check of the path of the barrier

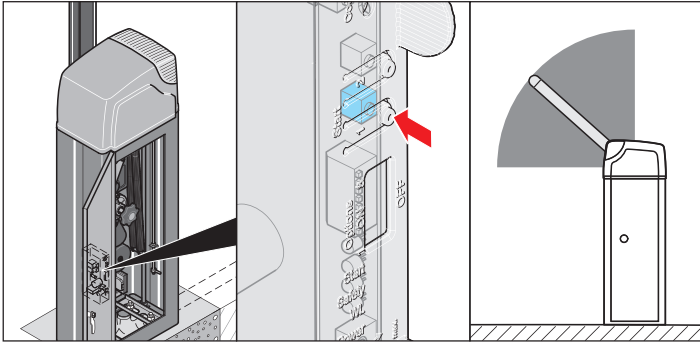

1. Press the button (1).
⇒ The barrier opens until the BARRIER OPEN end position is reached or until it is opened.
2. Press the button (1).
⇒ The barrier closes until the BARRIER CLOSED end position is reached.
3. Check that the barrier reaches the end positions.
⇒ If necessary, adjust the path of the barrier.

Adjustment of the path of the barrier using the end position

1. De-energize the barrier and secure it against reactivation.

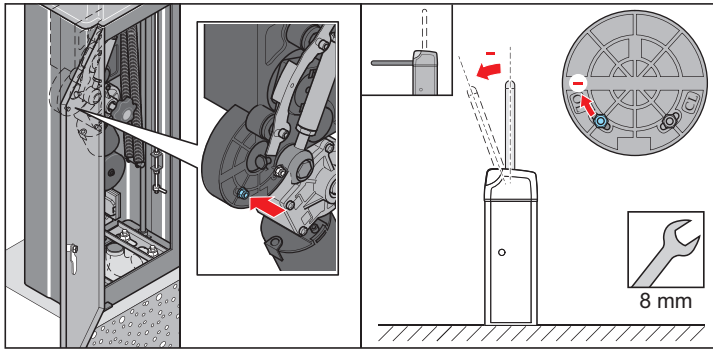

2. Open the door of the barrier housing.
3. To adjust the **upper end position (OL)**, loosen the nuts (8 mm) and push them in the oblong holes.
 - In the – direction, the path shortens by a maximum of 8°.



WARNING

Reed sensors for the barrier control system are located under the nuts.

If the nuts are tightened too strongly, the reed sensors are destroyed and irreparable damage to the barrier may result.

➤ Tighten the nuts (8 mm) only slightly.



NOTE!

Illustration for barrier closing on the left

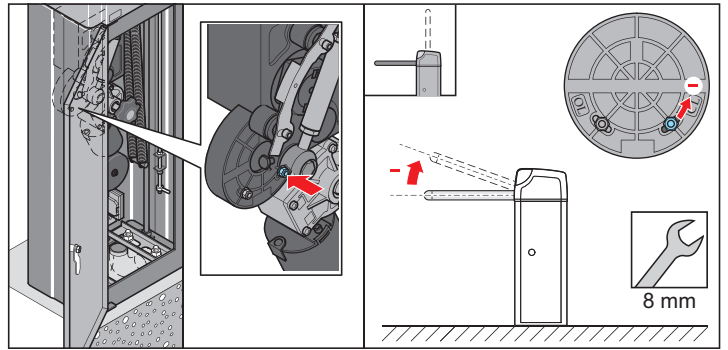

4. To adjust the **lower end position (CL)**, loosen the nuts (8 mm) and push them in the oblong holes.
 - In the – direction, the path shortens by a maximum of 3°.



WARNING

Reed sensors for the barrier control system are located under the nuts.

If the nuts are tightened too strongly, the reed sensors are destroyed and irreparable damage to the barrier may result.

➤ Tighten the nuts (8 mm) only slightly.

5. To check the path of the barrier, see the "**Commissioning - Check of the Path of the Barrier**" chapter.

Adjustment of the path of the barrier using the swivel range



NOTE!

During the adjustment of the swivel range, the angle between both end positions changes only minimally. Both end positions are pushed evenly in one direction.

1. De-energize the barrier and secure it against reactivation.

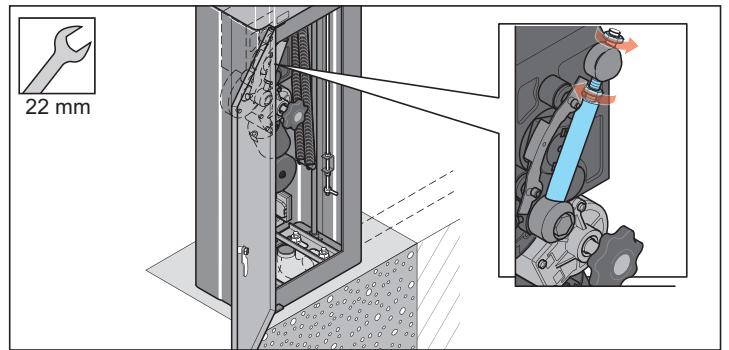

2. Open the door of the barrier housing.
3. Loosen both nuts (22 mm).

Initial operation

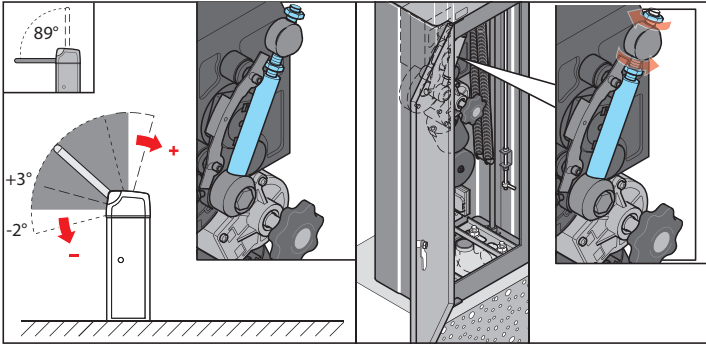

4. Adjust the swivel range manually.
5. Tighten both nuts (22 mm).
6. To check the path of the barrier, see the "**Commissioning - Check of the Path of the Barrier**" chapter.

Performing a control system reset and relearning the force values

The control system has an automatic force setting. The control system memorizes the required force during the "OPEN" and "CLOSE" barrier movements and stores it when the end position has been reached.

Read the correct force values. To do so, reset the control system:

To reset the control system:

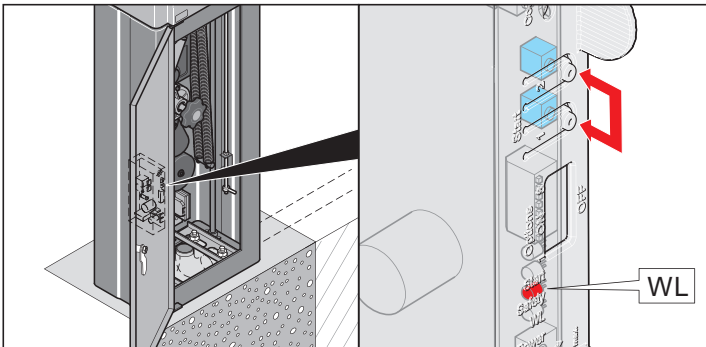

1. Press the buttons (1 + 2) until the "WL" LED extinguishes.
⇒ "WL" LED off - force values deleted.
2. Press the buttons (1+2).
3. Press the button (1).
⇒ The barrier closes.
4. Program the force values (min. 2 cycles)

Learn the force values:

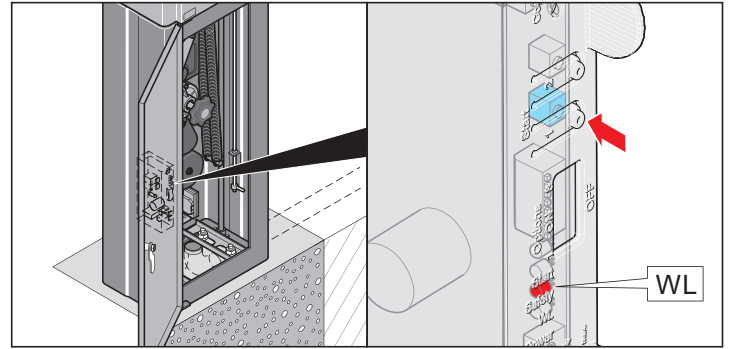

1. Press the button (1).
⇒ The barrier opens until the BARRIER OPEN end position is reached.
⇒ The "WL" LED flashes.
2. Press the button (1).
⇒ The barrier closes until the BARRIER CLOSED end position is reached.
⇒ The "WL" LED flashes.
3. Repeat Steps 1 and 2 three times.
⇒ The "WL" LED lights up and extinguishes - the force values have been learned.
4. To check the path of the barrier, see the "**Commissioning - Check of the Path of the Barrier**" chapter.

Adjusting the force tolerance



WARNING!

If the force tolerance is set too high, the barrier closes even if a considerable resistance is present.

Severe injuries or property damage may result!

- The adjustment of the force tolerance is safety-relevant and must be performed by qualified personnel with utmost care.
- Select a force tolerance that is as low as possible so that obstacles are detected quickly and safely.

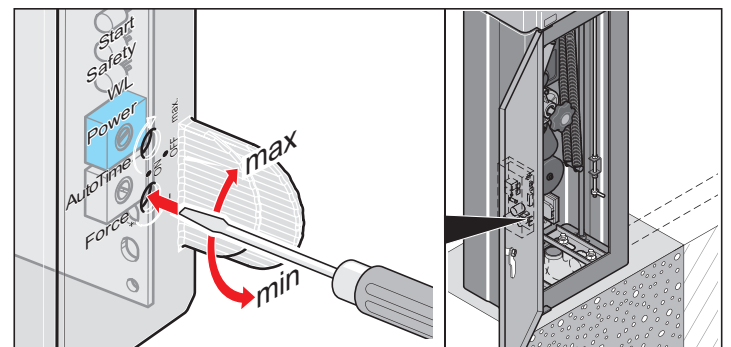

- Set the force tolerance using the "Force" potentiometer of the control system.



NOTE!

The set force tolerance is read in again each time the barrier is opened.

Optional hand-held transmitter

Safety information for the remote control

- The remote control may only be used for equipment and/or systems where interference in the transmitter or receiver does not pose a risk to humans, animals, or objects, or where the risk is covered by other safety devices.
- The remote control may only be used in case of direct visual contact with the barrier can be watched and no persons or objects are within the range of movement.
- Store the hand-held transmitter of the remote control in such a way so that an unintended operation e.g., by children or animals, is prevented.
- The operator of the radio system is not protected from faults due to other telecommunications equipment or devices (e.g. radio-controlled systems that are licensed to operate in the same frequency range). If substantial interference occurs, please contact your appropriate telecommunications office which has radio interference measuring equipment (radiolocation).
- Do not operate the hand-held transmitter in areas with sensitive radio communications or systems (e.g. airports, hospitals).

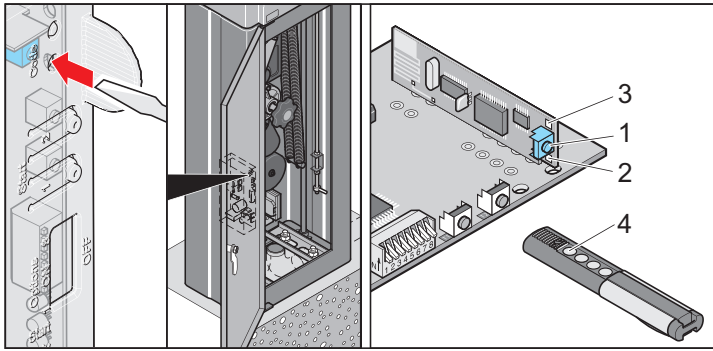

Deleting the radio receiver memory

1. Press and hold the Learn button (1).
 - ⇒ After 5 seconds, the LED flashes (3.1 or 3.2).
 - ⇒ After another 10 seconds, the LED lights up steadily (3.1 or 3.2).
 - ⇒ After a total of 25 seconds, all LEDs light up steadily (3.1 and 3.2).
2. Release the Learn button (1) - the deletion procedure is ended.

Programming the hand-held remote control



NOTE!

Before the first learning of the hand-held transmitter, delete the memory of the radio receiver.

1. Press the learn button (1).
 - 1 x for channel 1; the LED (3.1) lights up.
 - 2 x for channel 2; the LED (3.2) lights up.
 - ⇒ If no code is sent within 10 seconds, the radio receiver switches to Normal mode.
2. Press the desire hand-held transmitter button (5) until the LED (3.1/3.2) extinguishes, depending upon which channel has been selected.
 - ⇒ LED extinguishes - programming is finished.
 - ⇒ The hand-held transmitter has transferred the radio code to the radio transmitter.
3. For the additional programming of hand-held transmitters, repeat the steps above. A maximum of 112 memory locations are available for each radio receiver.

Canceling the Learn mode:

Press the Learn button (1) until no more LEDs are lit.

Deleting the hand-held transmitter from the radio receiver

If a hand-held transmitter is to be deleted from the radio receiver, **every** button and **every** shortcut of the hand-held transmitter must be deleted for security reasons!

1. Press the learn button (1) and keep it pressed for five seconds.
 - ⇒ An LED flashes (3.1 or 3.2).
2. Press the learn button (1).
 - ⇒ The radio receiver is in Deletion mode.
3. Press the hand-held transmitter button whose code should be deleted in the radio receiver.
 - ⇒ The LED extinguishes. The deletion procedure is ended.
4. Repeat the procedure for **all** buttons and shortcuts.

Deleting a channel from the radio receiver

1. Press and hold the Learn button (1).
 - 1 x for channel 1; the LED (3.1) lights up.
 - 2 x for channel 2; the LED (3.2) lights up.
 - ⇒ After 5 seconds, the LED flashes (3.1 or 3.2).
 - ⇒ After another 10 seconds, the LED lights up steadily (3.1 or 3.2).
2. Press the learn button (1).
 - ⇒ The deletion procedure is ended.

Loss of a hand-held transmitter

If a hand-held transmitter is lost, the entire memory of the radio receiver must be deleted for security reasons; see the "**Optional Hand-Held Transmitter - Deleting the Memory of the Radio Receiver**" chapter.

After that, relearn all hand-held transmitters.

Operation and control

Safety information on operation

- The boom attachment is designed for wind strengths up to a maximum of 8 on the Beaufort scale (stormy wind). In case of storm warnings and wind strengths greater than 8 on the Beaufort scale, one of the following must be performed in a **timely** manner:
 - Close the barrier and de-energize it.
 - Disassemble the boom.
- During normal operation:
 - The upper cover of the barrier must be put into place and locked.
 - The door of the barrier housing must be closed and locked.
- Before opening the barrier housing, de-energize all lines. In case of an opened barrier housing, make sure that the lines remain de-energized. When the barrier housing is opened, risks arise due to the following:
 - Tension springs under tension.
 - Crushing and scraping points in the vicinity of the drive connecting rod and the linkage.
- When the barrier housing is open, protect the control system and mains supply lines from moisture.
- Operate the barrier only when all safety devices are present and fully functional. As soon as a safety device is not functional, the barrier must be decommissioned until the malfunction has been properly eliminated.
- Do not let the barrier be used by several vehicles at once.
- Drive through the barrier only after it has opened completely.
- During operation, never hold the boom or reach into moving parts.
- During the opening and closing procedures, no people or objects may be in the vicinity of the boom.
- The opening and closing procedures must be observed by the user.
- Do not place objects on the barrier housing or boom.
- Do not climb onto the barrier.
- The surface temperature of the motor may rise to 80 °C, resulting in a risk of burning.

Operation with automatic closing function

- During operation with automatic closing, observe the applicable standards. Secure the closing level of the barrier with safety devices.



DANGER

The automatic closing function without safety devices also closes the barrier if people or objects are underneath.

Severe injuries or property damage may result.

- **Install the necessary safety devices (photo eyes, induction loops, 8.2 kOhm safety contact strip or OSE system) according to EN 12453.**

In the case of the automatic closing function, the barrier closes automatically after a set open time. The open time is counted down starting when the BARRIER OPEN end position is reached. If another opening command is made during the open time, the open time restarts.

The barrier can be opened, but not closed with a command initiator. During opening, the barrier cannot be stopped using a command initiator.

If an opening command is made once again during the automatic closing of the barrier, the barrier opens completely and the open time restarts.

Setting the automatic closing function:

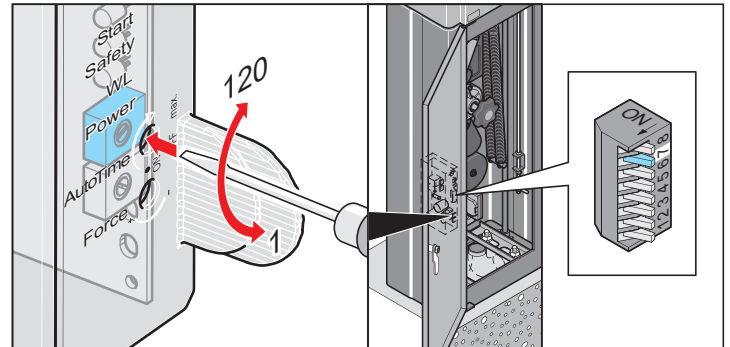

- The open time can be set using the "AUTO TIME" potentiometer of the control system. The open time can be set between 1 - 120 seconds.
- Set DIP switch 7 to "OFF".

Set other DIP switches as desired; see the "**Control System - DIP Switches**" chapter.

Operation and control

Single channel operation

In single-channel operation, **one** command initiator is used to open and close the barrier.

Setting single channel operation

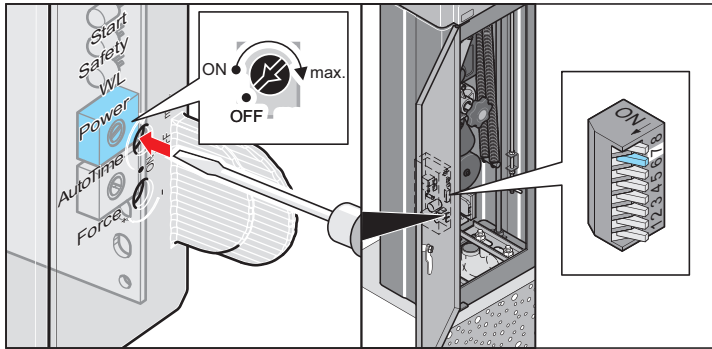

- The automatic closing function can be set using the "AUTO TIME" potentiometer of the control system. Deactivation via the left stop of the potentiometer.
- Set DIP switch 7 to "OFF".

Set other DIP switches as desired; see the "**Control System - DIP Switches**" chapter.

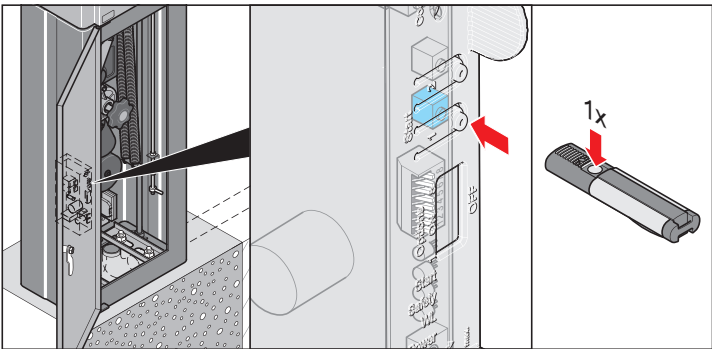

Opening the barrier single-channel operation

1. Press the button (1) or open the barrier using the command initiator.
2. If another command is set during the opening procedure, the barrier stops at the current position.
3. A further command closes the barrier.

Closing the barrier single-channel operation

1. Press the button (1) or close the barrier using the command initiator.
2. If another command is set during the closing procedure, the barrier stops at the current position.
3. A further command opens the barrier.

Pulse sequence of the barrier movement

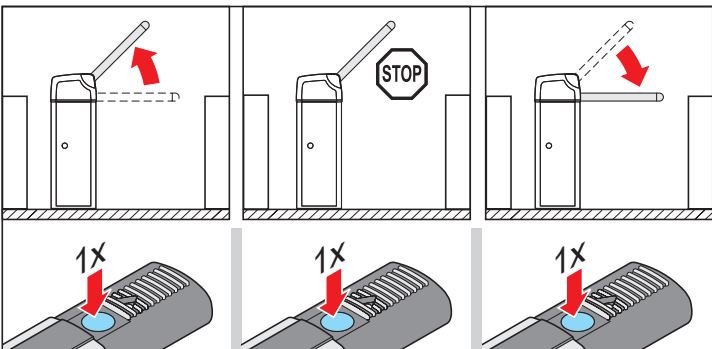

Command initiator 1: OPEN - STOP - CLOSE - STOP - OPEN - STOP - ...

Emergency release



WARNING!

If the emergency release is performed by only one person, the emergency release button transfers considerable forces onto the hand of the operating personnel.

Severe injuries may result!

- Perform the emergency release according to the instructions in these instructions and only with two people.

1. De-energize the barrier and secure it against reactivation.

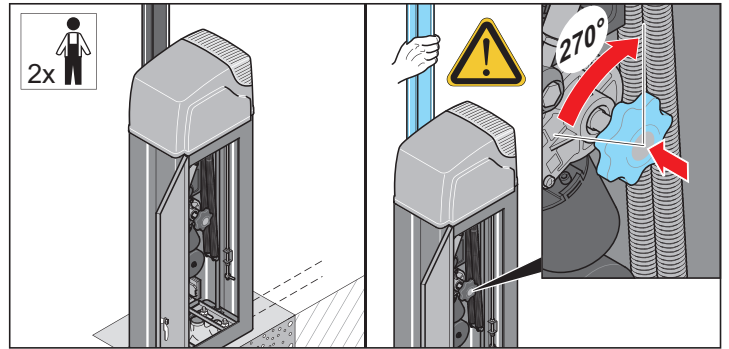

2. Open the door of the barrier housing.
3. Have a second person hold the boom. At the same time, press the emergency release button and turn it about 270° clockwise or counterclockwise.
 - ⇒ The barrier has been released.

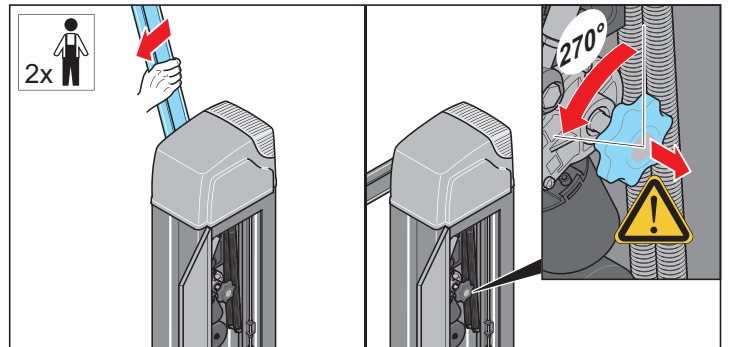

4. Open or close the barrier with the emergency release button. The second person must assist by moving the boom.
5. After reaching the desired boom position, turn the emergency release button about 270° clockwise or counterclockwise to the center position.
 - ⇒ The emergency release button snaps back.
 - ⇒ The barrier has been released.

Control

Safety instructions

- Protect the control system from moisture.
- Do not apply external voltage to the connections of the control system, otherwise the control system is immediately destroyed.
- The reverse polarity protection (yellow plug) must always be installed between Terminals 11 + 12.
- Only use the control system provided by SOMMER Antriebs- und Funktechnik GmbH; all other control systems would be damaged or would damage the drive.

Overview of the control system

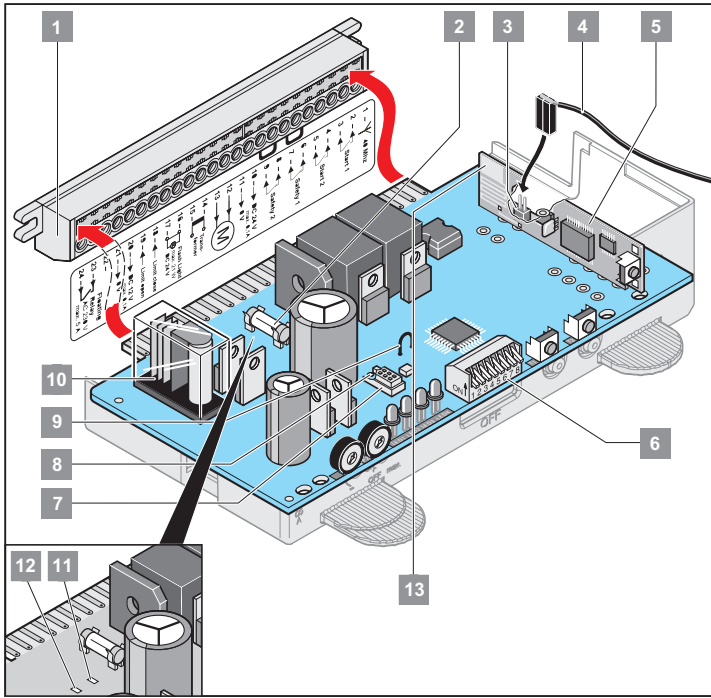

1	Direct connector, 24-pole
2	Fuse for the connection of the warning light (1 A fast-acting)
3	Connection of the external antenna
4	External antenna
5	Radio receiver
6	DIP switches
7	Connection of TorMinal
8	Protection against incorrect insertion for the connection of TorMinal
9	Wire jumper, disconnecting switches off the soft running
10	Relay contact, Terminals 23 + 24
11	LED: Left-closing design of barrier: Barrier CLOSED end position Right-closing of barrier: Barrier OPEN end position
12	LED: Left-closing design of barrier: Barrier OPEN end position Right-closing of barrier: Barrier CLOSED end position
13	Internal antenna

Direct connector, 24-pole

Permissible cable cross-section: max. 1.5 mm².

Terminal	Max. permissible cable length
10, 11, 16, 17, 20, 21	10 m
2, 3, 4, 5, 6, 7, 8, 9	30 m

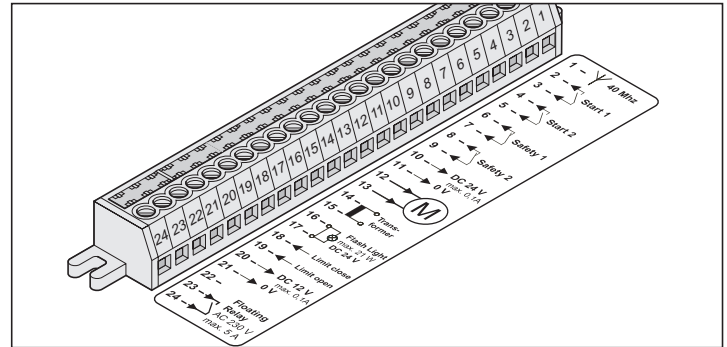

Terminal	Pin assignment/ cable color	Connection/name
1	Unassigned	Connection of the 40MHz antenna
2 + 3	Unassigned	Button 1
4 + 5	Unassigned	Button 2
6 + 7	Jumper	Tested connection for floating contacts, safety input 1
8 + 9	Jumper	Tested connection for floating contacts, safety input 2
10	Unassigned	Regulated DC 24 V, max. 0.1 A
11	Unassigned	Ground
12	Black	Motor
13	Red	Motor
14 + 15	Red	Secondary transformer
16 + 17	Unassigned	Warning light, unregulated DC 24 V (max. 34 V) 25 watt, max. 1 A
18	Right-closing barrier: Blue	Barrier CLOSED sensor
	Left-closing barrier: Red	
19	Right-closing barrier: Red	Barrier OPEN sensor
	Left-closing barrier: Blue	
20	Unassigned	Regulated DC 12 V, max. 0.1 A
21	Green	Barrier CLOSED sensor
	Yellow	Barrier OPEN sensor
	-	Ground for Terminal 20
22	-	-
23 + 24	Unassigned	Floating relay output, AC 230 V, max. 5 A

Control

Display and button explanation

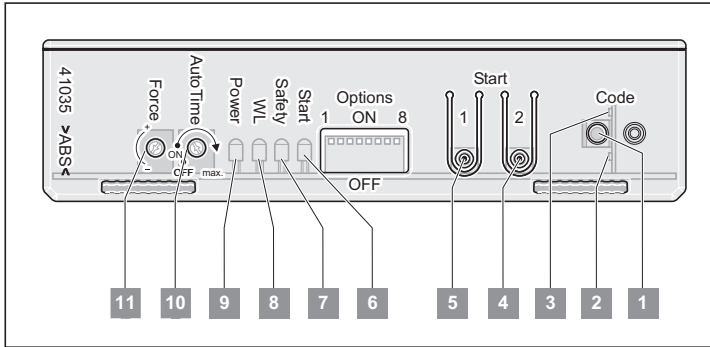

1	Learn button
2	LED radio channel 1
3	LED radio channel 2
4	Button 2
5	Button 1
6	Start LED Lights up when a radio command is sent or a button is pressed.
7	Safety LED Lights up when a safety input is actuated.
8	"WL" LED Flashes when the drive opens or closes the barrier.
9	Power LED Lights up when mains voltage is present.
10	Potentiometer for adjusting the open time of the automatic closing function.
11	Potentiometer for adjusting the power tolerance.

Mains connection

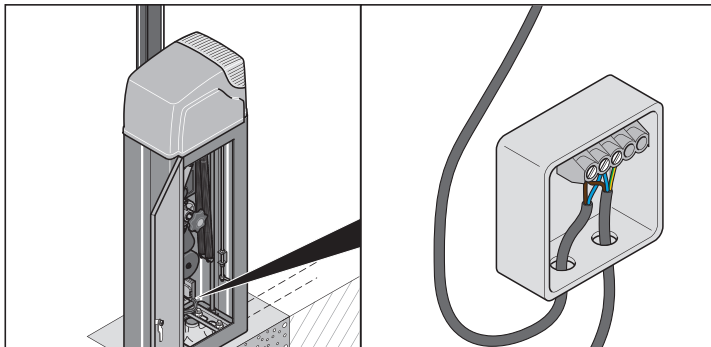

Terminal	Cable color	Name
--	Yellow/green	(PE)
Brown	Brown	(L) AC 220 - 240 Volt
Blue	Blue	(N)

Functions of the control system

Break-in protection due to automatic lock

If someone tries to open the barrier by hand without releasing the barrier, the drive tries to hold the barrier closed or to close it.

Overload protection

If the drive of the barrier is overloaded during opening or closing, the control system detects that and stops the drive.

After about 20 seconds or a control system reset, the control system releases the overload protection again. The barrier can now resume operation.

Automatic force cut-off

Through the automatic force cut-off, the barrier reverses when it hits an obstacle during opening and closing.

In order for the automatic force cut-off to work correctly:

- Read the force values.
- Adjust the force tolerance.

See the "**Commissioning - Performing a Control System Reset and Relearning the Force Values**" and "**Commissioning - Adjusting the Force Tolerance**".

Operation after a power failure

The programmed force values are retained in the event of a power failure. The first movement of the drive after a power failure is always Barrier OPEN.

HomeLink-compatible

If a vehicle is equipped with a HomeLink system (Version 7), the radio receiver of the barrier is compatible with it at 868.6 MHz. In the case of older HomeLink systems, another radio frequency (40.685 or 434.42 MHz) must be used.

More information under: "<http://www.eurohomelink.com>"

Pulse for the light control system

For every start of the drive, a pulse is present at the relay output so that lighting can be additionally switched on, for example. For the connection and data, see the "**Connection - Direct Connector, 24-Pole**".

Control

DIP switches

The settings of the barrier are changed using the DIP switches.



NOTE

Before switching the DIP switches, disconnect the power supply of the barrier/control system.

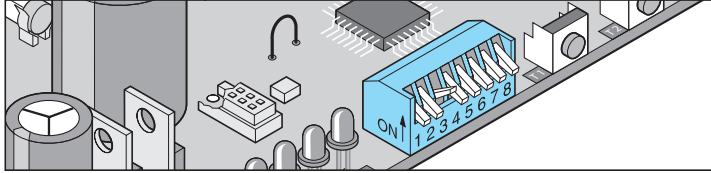

To switch the individual DIP switches, use a small screwdriver.

DIP switches	Position	Function/reaction
Obstacle detection during the opening of the barrier		
1	OFF	No reaction of the drive
	ON	The drive stops and closes the barrier completely
Selection of the safety device at the safety input 1		
2	OFF	Selection of the NC contact (e.g. photo eye or loop evaluation)
	ON	Selection of the safety contact strip
Obstacle detection during the closing of the barrier		
3	OFF	Impermissible setting
	ON	The drive stops and opens the barrier completely
Close command due to safety input		
4	OFF	Deactivated
	ON	Activated
Prewarning time of the connected warning light		
5	OFF	Prewarning time 0 sec.
	ON	Prewarning time 3 sec. - warning light flashes
OSE system at safety input 1		
6	OFF	Deactivated, no OSE system connected
	ON	Activated, OSE system connected
Selection of the operating mode		
7	OFF	Operation with automatic closing function or single-channel operation
	ON	Impermissible setting

DIP 1 - obstacle detection during the opening of the barrier

If a signal is present at safety input 1 when the barrier is opened (e.g. a vehicle drives through the photo eye), the barrier reacts according to the setting of the DIP switch 1.

In case of a signal at safety input 2, the barrier does **not** react.

DIP 2 - selection of the safety device to safety input 1

Using DIP switch 2, select the safety device connected to safety input 1.

If an OSE system (optical safety contact strip) is connected to safety input 1, it is activated via DIP switch 6.

DIP 3 - obstacle detection during the closing of the barrier

If a signal is at safety input 1 or 2 when the barrier is closed (e.g. the vehicle moves through the photo eye), the barrier stops and opens completely.

DIP 4 - closing command through safety input

The barrier can be closed automatically in any operating mode through a safety input that has become free.

As soon as safety inputs 1 and 2 become free when the barrier is open, the barrier closes after a fixed open time of five seconds.

DIP 5 - prewarning time of the connected warning light

To warn the user, a connected warning light flashes for three seconds before the opening and closing of the barrier.

DIP 6 - OSE system at safety input 1

If an OSE system (optical safety contact strip) is connected to safety input 1, the evaluation of the OSE system is activated via DIP switch 6.

Regular testing and maintenance



NOTE:

Using this testing plan, test the barrier at the required intervals and document and archive the test result!

- Test interval using this test plan: annual.
- Test interval of the pressure-sensitive safety devices (e.g. 8.2 kOhm safety contact strip): every 4 - 6 weeks.
- The entire barrier is maintenance-free.

Testing	Behavior	Yes/ no	Possible causes	Remedy	Date and tester
Force cut-off					
Stop the boom at a closing angle of about 45° when closing with a 2 meter high object.	The drive reverses when it hits the object.	Yes	The force cut-off works without limitations.	Leave all settings as they are.	
		No	Force tolerance too high. Set it using the "Force" potentiometer or TorMinal.	Reduce the force tolerance until the test is successful. Before that, open and close the barrier completely twice under supervision. See the " Commissioning - Adjusting the Force Tolerance " or " TorMinal Instructions " chapter.	
Emergency release					
Proceed as described in the " Operation and Control - Emergency Release " chapter.	The barrier must be easily opened/closed by hand.	Yes	Everything is OK.		
		No	Emergency release defective.	Have the emergency release repaired; call the Customer Service of SOMMER Antriebs- und Funktechnik GmbH for this purpose.	
Visual inspection					
Check the boom and the barrier housing for obvious defects, damage from vehicles, environmental influences, or vandalism.	The barrier shows damage.	No	Everything is OK.		
		Yes	Boom or barrier housing damaged.	Decommission the barrier and secure it against reactivation. Have the barrier or damaged parts repaired or exchanged; call the Customer Service of SOMMER Antriebs- und Funktechnik GmbH for this purpose.	
			Warning signs or reflectors on the barrier damaged.	Replace the warning signs or reflectors.	
8.2 kOhm safety contact strip if present					
Close the barrier and actuate the 8.2 kOhm safety contact strip in the process.	Adjust the behavior of the barrier as in the case of DIP switch 1 or 2. Safety LED lights up.	Yes	Everything is OK.		
		No	Cable breakage, terminal loose.	Check the wiring; retighten the terminals.	
			DIP switch adjusted.	Set the DIP switch.	
No	Strip defective.	Decommission the barrier and secure against reactivation; contact the Customer Service department of SOMMER Antriebs- und Funktechnik GmbH.			
Photo eye, if present					
Open/close the barrier, disconnecting the photo eye in the process.	Adjust the behavior of the barrier as in the case of DIP switch 1 or 2. Safety LED lights up.	Yes	Everything is OK.		
		No	Cable breakage, terminal loose.	Check the wiring; retighten the terminals.	
			DIP switch adjusted.	Set the DIP switch.	
			Photo eye dirty.	Clean the photo eye.	
			Photo eye adjusted (holder bent).	Adjust the photo eyes.	
No	Photo eye defective.	Decommission the barrier and secure against reactivation; contact the Customer Service department of SOMMER Antriebs- und Funktechnik GmbH.			
Induction loop, if present					
Open/close the barrier, disconnecting the induction loop in the process.	Adjust the behavior of the barrier as in the case of DIP switch 1 or 2. Safety LED lights up.	Yes	Everything is OK.		
		No	Cable breakage, terminal loose.	Check the wiring; retighten the terminals.	
			DIP switch adjusted.	Set the DIP switch.	
No	Induction loop defective.	Decommission the barrier and secure it against reactivation. Repair or exchange the induction loop or damaged parts.			
Spring tension					
Bring the boom into a 45° angle with the emergency release button and hold it there.	The boom remains at an angle of 45° when released.	Yes	Everything is OK.		
		No	Incorrect spring setting	Check and correct the spring setting; see the " Commissioning - Adjusting the Spring Unit " chapter.	

Troubleshooting

Change the fuse.

1. De-energize the barrier and secure it against reactivation.

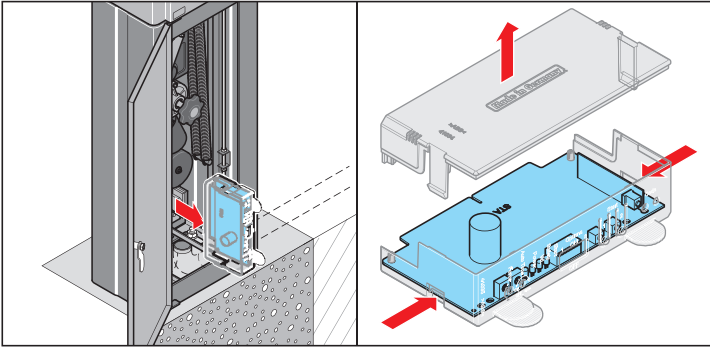

2. Open the barrier house.
3. Expand the control system (3) and open the control system housing.

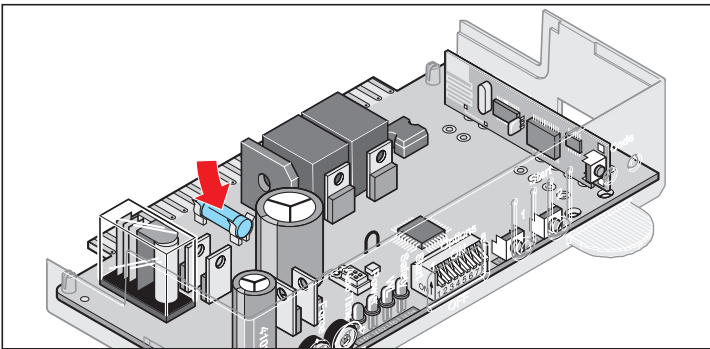

4. Exchange the defective fuse (1) (1 A fast-acting fuse).

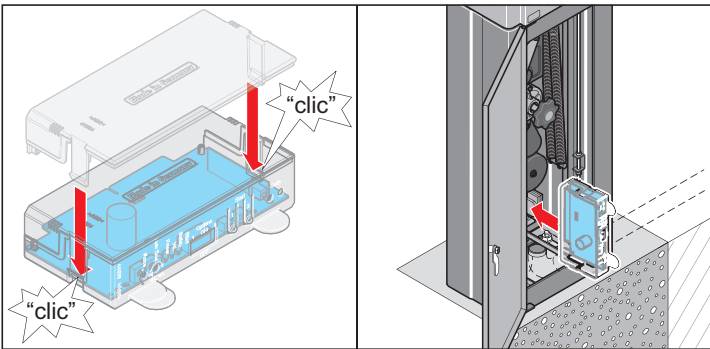

5. Close the control system housing and install the control system (3).
6. Close the barrier house.

Changing the spring

1. De-energize the barrier and secure it against reactivation.

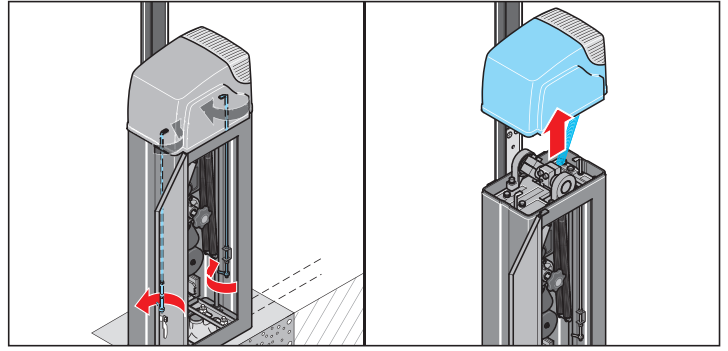

2. Open the door of the barrier housing and loosen the lock of the cover.
3. Remove the top cover of the barrier and disconnect the cover cable at the barrier housing.

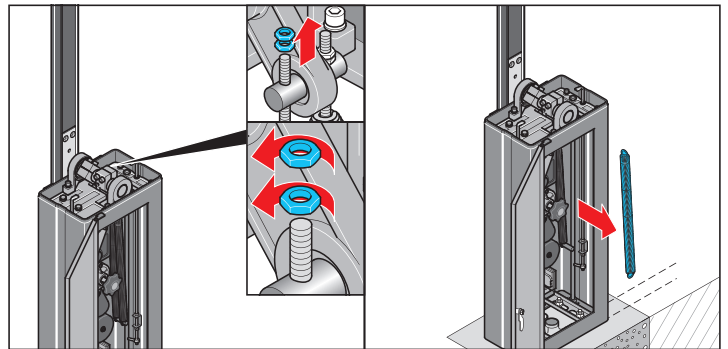

4. Loosen both nuts of the broken springs.
5. Remove the broken springs.

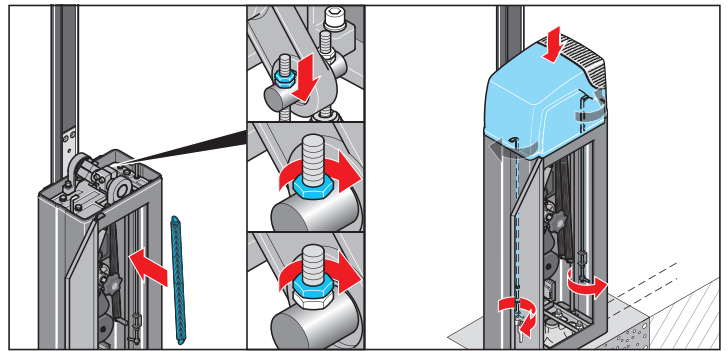

6. Insert new springs and fasten with nuts.
7. To adjust the spring unit, see the "**Commissioning - Adjusting the Spring Unit**" chapter.
8. Close the barrier house.

Troubleshooting

Changing lights

Replacing lights on warning light cover

1. De-energize the barrier and secure it against reactivation.

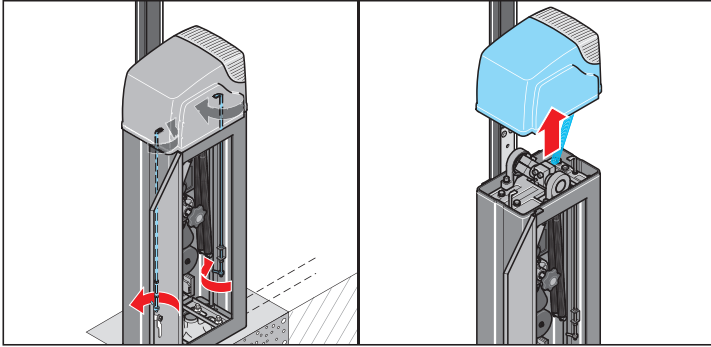

2. Open the door of the barrier housing and loosen the lock of the cover.
3. Remove the top cover of the barrier and disconnect the cover cable at the barrier housing.

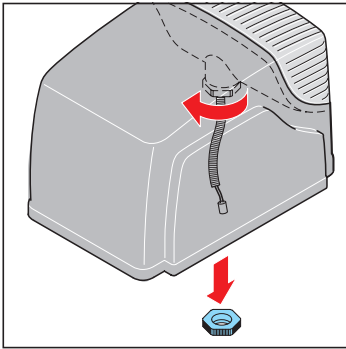

4. Loosen the cable gland on the back of the cover.

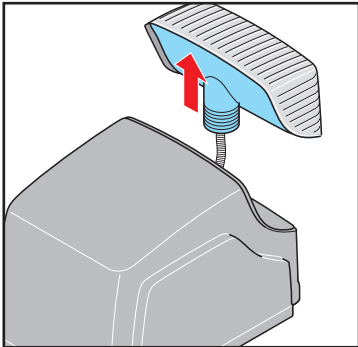

5. Remove the light cover housing from the cover.

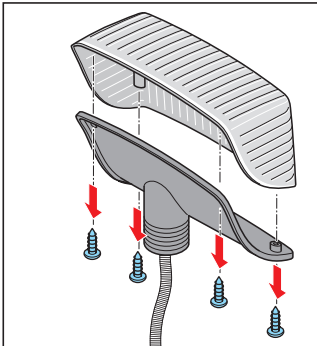

6. Unscrew the 4 screws and take off the back of the cover.

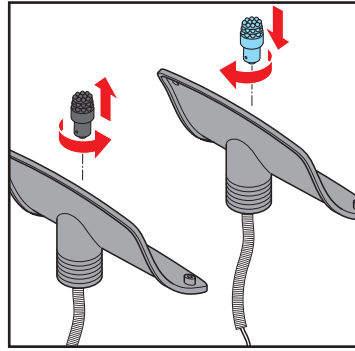

7. Replace lights (bayonet connection).

Troubleshooting

Fault - cause - elimination

- All work within the scope of troubleshooting may only be performed by trained personnel; see the "**Safety Information - Qualification of the Personnel**" chapter. The personnel must be familiar with the special risks of the decommissioning protective devices and know which special safety measures must be made during the elimination of the malfunctions.
- Shut down all command initiators so that the barrier does not move in an uncontrolled manner.
- Safety devices may only be jumpered, switched off, or removed if it has been guaranteed by suitable measures that there is still no danger from the barrier.
- Secure the working area during troubleshooting. Use boundary tape and warning signs. Never leave the working area unattended.
- Make sure that no tools or other aids are in or on the barrier at the end of troubleshooting.
- For work performed above body height, used suitable, tested, and stable climbing aids.
- Before starting operation again, mount and check all safety devices.

Malfunction	Possible causes	Corrective action
The barrier does not open or close.	No mains voltage present; the Power LED does not light up.	<ul style="list-style-type: none"> • Switch on main switch. • Check the fuse of supply line. • Check the supply line.
	No control system installed.	<ul style="list-style-type: none"> • Install the control system.
	Control system not properly plugged in.	<ul style="list-style-type: none"> • Plug the control system correctly into the connector.
	Automatic closing function activated.	<ul style="list-style-type: none"> • The barrier closes automatically when the set time is up. For the settings, see the "Operation and Control - Operation with Automatic Closing Function" chapter.
	Spring torn.	<ul style="list-style-type: none"> • Change the spring; see the "Troubleshooting - Changing the Spring" chapter.
	The barrier has been released.	<ul style="list-style-type: none"> • Open the emergency release of the barrier; see the "Operation and Control - Emergency Release" chapter.
	The safety device prevents closing; the Safety LED lights up.	<ul style="list-style-type: none"> • Free the safety device. • Check the safety device. • Clean the photo eye.
	The connected 8.2 kOhm safety contact strip is defective or DIP switch 2 is OFF; the Safety LED lights up.	<ul style="list-style-type: none"> • Set DIP switch 2 to "ON". • Exchange 8.2 kOhm safety contact strip.
	The OSE system is switched on, but the induction loop, photo eye, or 8.2 kOhm safety contact strip is connected. The Safety LED lights up.	<ul style="list-style-type: none"> • Switch off the OSE system; set DIP switch 6 to OFF.
The overload protector has switched off the barrier.	<ul style="list-style-type: none"> • Wait 20 seconds until the control system releases the barrier again. 	
The barrier does not open or close when a hand-held transmitter is actuated.	The battery of the hand-held transmitter is empty; the LED on the hand-held transmitter does not light up.	<ul style="list-style-type: none"> • Exchange the battery of the hand-held transmitter.
	The hand-held transmitter has not be learned on the radio receiver.	<ul style="list-style-type: none"> • Learn the hand-held transmitter; see the "Optional Hand-Held Transmitter - Learning the Hand-Held Transmitter" chapter.
	The command is constantly present because the button of the hand-held transmitter is jammed. The Start LED and the LED on the hand-held transmitter light up.	<ul style="list-style-type: none"> • Release the key or exchange the hand-held transmitter.
The barrier does not open or close when a command initiator (e.g. key switch) is actuated.	The command initiator is not connected or defective. The Start LED does not light up when the command initiator is actuated.	<ul style="list-style-type: none"> • Check the supply line of the command initiator. • Exchange the command initiator.
	A constant signal is present - water in the housing of the command initiator; the Start LED lights up.	<ul style="list-style-type: none"> • Exchange the command initiator and protect against moisture.
The barrier stops during closing, moves about 10 cm in the opposite direction, and stops.	Actuation of the force cut-off due to an obstacle.	<ul style="list-style-type: none"> • Remove obstacle.
	Incorrect force values learned.	<ul style="list-style-type: none"> • Perform a control system reset and relearn the force values. If this measure does not help, increase the force tolerance. See the "Commissioning - Adjusting the Force Tolerance" and "TorMinal Instructions" chapters.
	Barrier incorrectly adjusted or defective.	<ul style="list-style-type: none"> • Have the barrier adjusted or repaired by a specialist; call the Customer Service of SOMMER Antriebs- und Funktechnik GmbH for this purpose.

Troubleshooting

Malfunction	Possible causes	Corrective action
The barrier stops during opening, moves about 10 cm in the opposite direction, and stops.	Actuation of the force cut-off due to an obstacle. Incorrect force values learned.	<ul style="list-style-type: none"> Remove obstacle. Perform a control system reset and relearn the force values. If this measure does not help, increase the force tolerance. See the "Commissioning - Adjusting the Force Tolerance" and "TorMinal Instructions" chapters.
	Barrier incorrectly adjusted or defective.	<ul style="list-style-type: none"> Have the barrier adjusted or repaired by a specialist; call the Customer Service of SOMMER Antriebs- und Funktechnik GmbH for this purpose.
The barrier stops during opening.	Safety device activated and DIP switch 1 at ON.	<ul style="list-style-type: none"> Free the safety device activated or turn the DIP switch 1 to ON.
The boom is not balanced (45°) when in a de-energized state with the emergency release disengaged and lowers by itself.	Incorrect spring setting or spring breakage.	<ul style="list-style-type: none"> Check and correct the spring setting; see the "Commissioning - Adjusting the Spring Unit" chapter. Change the broken spring; see the "Troubleshooting - Changing the Spring" chapter.
The barrier opens only slowly, but closes very quickly with a hard impact in the lower end position/on the support post.	Incorrect spring setting or spring breakage.	<ul style="list-style-type: none"> Check and correct the spring setting; see the "Commissioning - Adjusting the Spring Unit" chapter. Change the broken spring; see the "Troubleshooting - Changing the Spring" chapter.
No light at connected warning light.	Fuse or bulb defective.	<ul style="list-style-type: none"> Change the fuse; see the "Troubleshooting - Changing the Fuse" chapter. Replace bulb.
Speed varies during opening and closing.		<ul style="list-style-type: none"> Completely normal: before the end positions are reached, the barrier reduces speed (soft running).
The barrier can be operated only as long as the button of a command initiator is pressed.	Deadman's function activated.	<ul style="list-style-type: none"> Deactivate the deadman's function; see the "TorMinal Instructions" chapter.
The Start LED is constantly lit.	Constant signal at button connection 1 or 2. An external signal is interfering with the control system of the barrier; LED 3.1 or 3.2 on the radio receiver lights up.	<ul style="list-style-type: none"> Check the connected command initiator. Wait until the external signal falls off. Remove the sources of the interference through the external signal.
Boom is hanging down.	The boom was bent with force or pressed up or down when in the closed position.	<ul style="list-style-type: none"> Have the barrier adjusted or repaired by a specialist; call the Customer Service of SOMMER Antriebs- und Funktechnik GmbH for this purpose.
Only radio receiver All LEDs flashing.	All memory locations occupied, max. 112.	<ul style="list-style-type: none"> Delete any hand-held remote controls that are no longer needed. Install additional radio receivers.
LED 3.1 or 3.2 lights up constantly.	The radio signal is being received; the button of a hand-held remote control might be defective or an external signal is present.	<ul style="list-style-type: none"> Remove the battery from the hand-held transmitter. Wait until the external signal falls off.
LED 3.1 or 3.2 lights up.	The radio receiver is in the Learning mode and awaiting a radio code from a hand-held remote control.	<ul style="list-style-type: none"> Press the desired hand-held transmitter button.
Only barriers with floating support The floating support of the barrier hits the ground hard in the lower end position.	The lower end position of the barrier has been incorrectly adjust, which means that the distance between the floating support and the ground is too short. In a closed state, the distance between the floating support and the ground must amount to about 2 cm.	<ul style="list-style-type: none"> Correct the lower end positions of the barrier; see the "Commissioning - Adjusting the Path of the Barrier via the End Positions" chapter.

If you cannot find the malfunction in the table and eliminate it, take the following measures:

- Perform a control system reset and then relearn the force values.
- Disconnect the connected accessories (e.g. photo eye) and reconnect the jumper for a safety connection.
- Set all DIP switches to the factory setting (OFF).
- If settings have been changed using TorMinal, perform a control system reset using TorMinal.
- Check all connections on the direct connectors and terminal strip and retighten if necessary.

In case of other problems, contact the Customer Service department of SOMMER Antriebs- und Funktechnik GmbH. The contact data of the headquarters in Germany are located on the back of the title page.

Disassembly and disposal

Safety information for disassembly

During disassembly, additional dangers that do not occur during operation must be expected since the safety devices are shut down to some extent.

- Perform disassembly only up to a maximum wind strength of 3 on the Beaufort scale (light wind).
- **At least two people** are required for the entire disassembly.
- Physically disconnect the power supply lines and energy buffer.
- For disassembly work performed above body height, used suitable, tested, and stable climbing aids. Never use the barrier or parts of the barrier as climbing aids.
- The disassembly of the barrier and all work on the electric system may only be performed by the personnel described in the "**Safety Information - Qualification of the Personnel**" chapter.



DANGER OF TIPPING!

The barrier may tip during disassembly.

People can be injured and the barrier can be damaged.

- Transport and disassembly may be performed only with two people and suitable transport equipment.

Storage after disassembly

If the barrier should be intermediately stored after disassembly, observe the provisions and regulations for storage listed in the "**Transport/Unloading/Storage - Storage**" chapter.

If possible, store the control system of the barrier separately.

Description of the disassembly work



DANGER!

In case of direct or indirect contact with live parts, current could flow through the body.

Electrical shock, burns, or death may result.

- Before starting disassembly, set the main switch to "0", secure it with a padlock, and attach a warning sign.
- Wait at least five minutes after deactivation so that the motor can cool down and the capacitors lose their voltage.

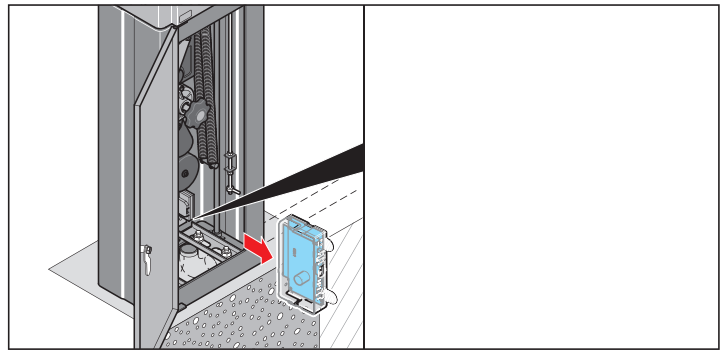

1. Remove the control system.
2. Disconnect the mains supply line and remove it.
3. Disassemble the connected accessories and disconnect the cable from the direct connector.

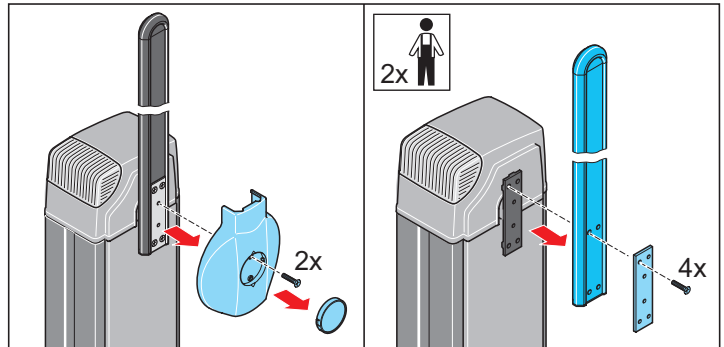

4. Remove the boom in the vertical opening position.
5. Remove the faceplate and disassembly the cover with two screws.
6. Loosen 4 screws from the boom and remove the boom and the shim plate.

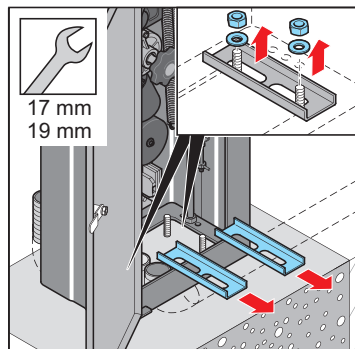

7. Open the barrier housing and loosen 4 nuts.
8. Remove the nuts, washers, and U-profiles.
9. Remove the barrier house.

Disassembly and disposal

Disposal

The disposal of the barrier, parts, operating materials, and adjuvants are subject to legal regulations to some extent. Precise information can be obtained from the responsible public administration authorities (e.g. water resource and environmental protection offices on a federal and state or provincial level).

Deliver the goods to be disposed of only to authorized receiving point.



WARNING

Environmental damage in case of incorrect disposal!

- **Electrical scrap, electrical components, lubricants, and other adjuvants are subject to treatment as hazardous materials and may only be disposed of by approved specialist companies.**

EC Declaration of Conformity

in accordance with the Machinery Directive 2006/42/EC, Appendix II, Section 1 A

SOMMER Antriebs- und Funktechnik GmbH
Hans - Böckler - Straße 21 - 27
73230 Kirchheim unter Teck
Germany

hereby declares that the product

ASB-6010A
ASB-5014A

as part of the identification ASB-6010A or ASB-5014A complies with the Machinery Directive 2006/42/EC. The machine complies with all requirements of the Low Voltage Directive (2006/95/EC) and the Electromagnetic Compatibility Directive (2004/108/EC)

- The following fundamental safety requirements have been applied and observed in accordance with Appendix I:

- General principles No. 1

- 1.2 Safety and reliability of control units

Safety input I terminals 6 + 7: Cat 2 / PL C

Optical safety contact strip terminals 6 + 20 + 21: Cat 2 / PL C

Electric 8.2 kΩ safety contact strip terminals 6 + 7: Cat 2 / PL C

Safety input II terminals 8 + 9: Cat 2 / PL C

Internal force limitation Cat 2 / PL C

Safety categories in accordance with EN 13849 - 1:2008

- Compliant with the regulations of the EC Building Products Guideline 89/106/EC.
For the operating forces part, the respective initial testing has been carried out in consultation with recognized inspecting authorities. In doing so, the harmonized standards EN 13241-1, EN 12453 and EN 12445 have been applied. For the tested combinations, refer to the "Reference list" table in the Internet under www.sommer.eu.
- Compliant with the Low Voltage Directive 2006/95/EC.
- Compliant with the EMC Directive 2004/108 08/EC.
- The technical documentation was drawn up in accordance with Appendix VII A.

The product may only be put into operation after it has been established that the door system complies with the regulations of the Machinery Directive.



A handwritten signature in blue ink, appearing to read 'Jochen Lude'.

Kirchheim, 12/29/2009

Jochen Lude
Responsible for documents



Entrance and exit scenarios

Example 1 - Parking lot with monitored entry and free exit

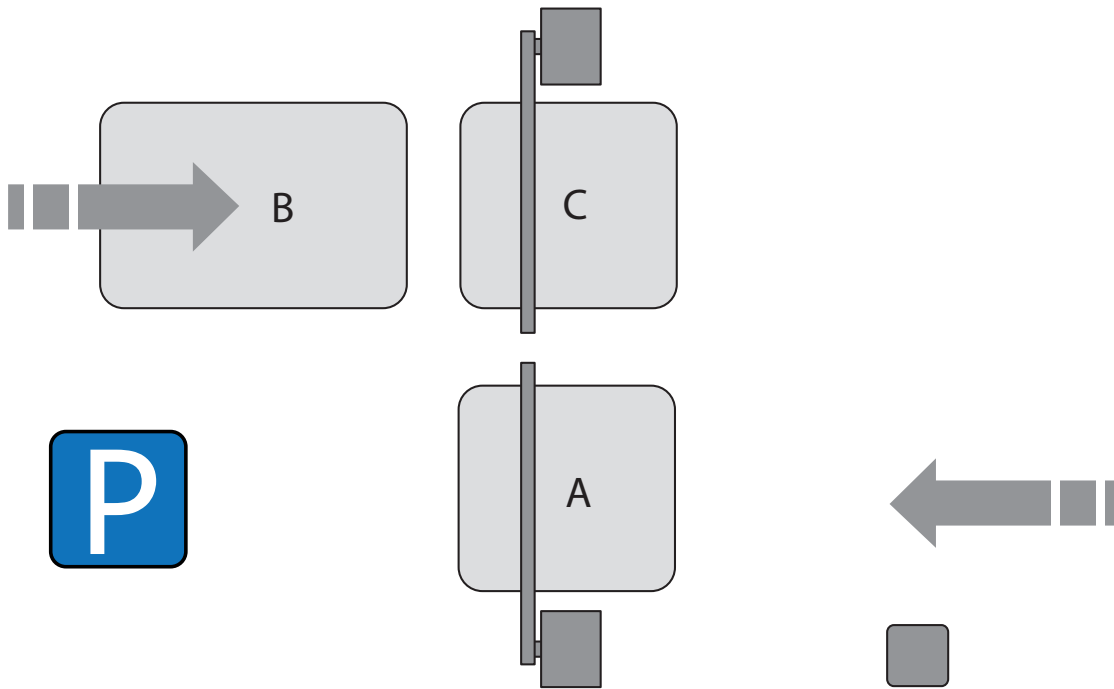

Barrier for entrance:

The barrier is manually opened using a command initiator or by hand-held transmitter and closed after 60 seconds using the automatic closing function. Induction loop A monitors the closing level according to EN 12453. The open time of the automatic closing function does not start until the vehicle leaves the induction loop. A connected warning light flashes for 3 seconds before the opening and closing of the barrier.

The barrier is adjusted as follows:

DIP	Position
1	OFF
2	OFF
3	ON
4	OFF
5	ON
6	OFF
7	OFF

Function/connection	Setting/terminal
Auto Time potentiometer	
Command initiator as Button 1	Terminals 2 + 3
Learned hand-held transmitter	-
Induction loop as safety input 1	Terminals 6 + 7
Warning light	Terminals 16 + 17

Barrier for the exit:

The barrier is automatically opened by induction loop B and closed after 30 seconds using the automatic closing function. Induction loop C monitors the closing level according to EN 12453. The open time of the automatic closing function does not start until the vehicle leaves induction loop C.

The barrier is adjusted as follows:

DIP	Position
1	OFF
2	OFF
3	ON
4	OFF
5	OFF
6	OFF
7	OFF

Function/connection	Setting/terminal
Auto Time potentiometer	
Induction loop A as Button 1	Terminals 2 + 3
Induction loop B as safety input 1	Terminals 6 + 7

Entrance and exit scenarios

Example 2 - Company entrance with gatehouse

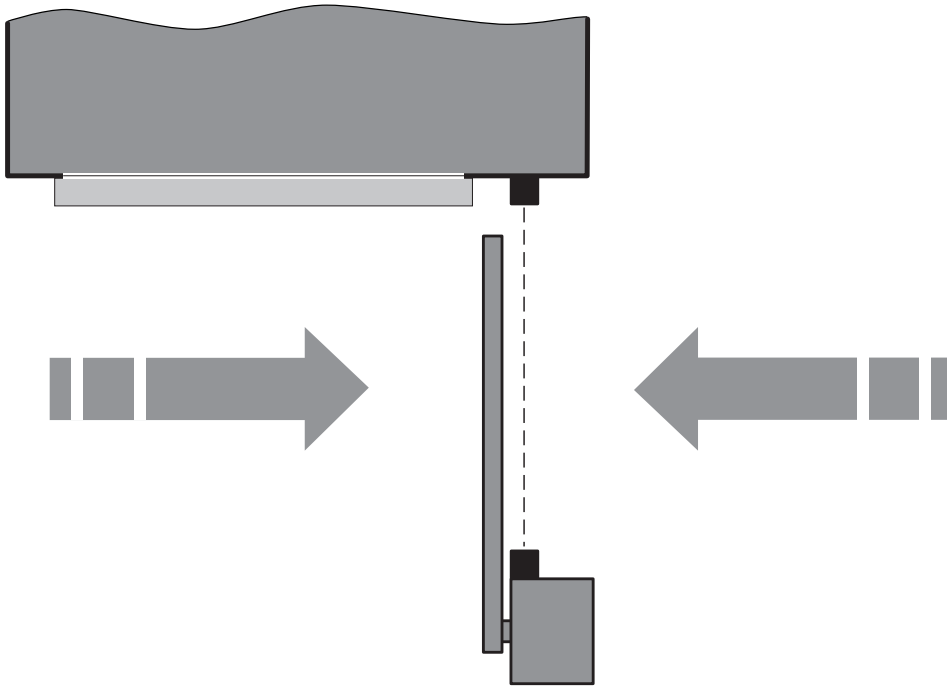

Barrier for entrance and exit:

The barrier is opened manually using a command initiator in single-channel operation and closed with the "Close command through safety input" setting. The photo eye monitors the closing level. When the vehicle leaves the photo eye, the barrier closes after 5 seconds.

The barrier is adjusted as follows:

DIP	Position
1	OFF
2	OFF
3	ON
4	ON
5	OFF
6	OFF
7	OFF

Function/connection	Setting/terminal
Auto Time potentiometer	
Command initiator as Button 1	Terminals 2 + 3
Photo eye as safety input 2	Terminals 8 + 9

Entrance and exit scenarios

Example 3 - Parking lot with free entry and monitored exit

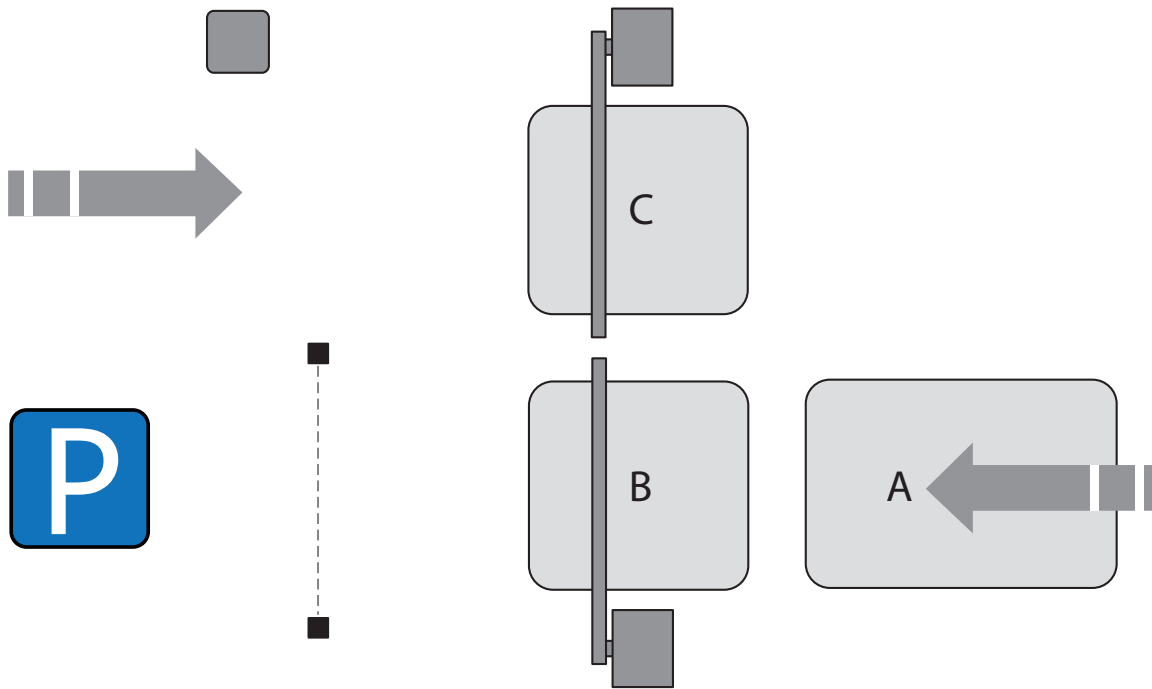

Barrier for entrance:

The barrier is automatically opened by induction loop A and closed using the "Close command through safety input" setting. Induction loop B monitors the closing level according to EN 12453. The photo eye also monitors the entrance. When the vehicle leaves the photo eye, the barrier closes after 5 seconds.

The barrier is adjusted as follows:

DIP	Position
1	OFF
2	OFF
3	ON
4	ON
5	OFF
6	OFF
7	OFF

Function/connection	Setting/terminal
Auto Time potentiometer	
Induction loop as Button 1	Terminals 2 + 3
Induction loop as safety input 1	Terminals 6 + 7
Photo eye as safety input 2	Terminals 8 + 9

Barrier for the exit:

The barrier is manually opened using a command initiator or by hand-held transmitter and closed after 120 seconds using the automatic closing function. Induction loop C monitors the closing level according to EN 12453. The open time of the automatic closing function does not start until the vehicle leaves induction loop C.

The barrier is adjusted as follows:

DIP	Position
1	OFF
2	OFF
3	ON
4	OFF
5	OFF
6	OFF
7	OFF

Function/connection	Setting/terminal
Auto Time potentiometer	
Command initiator as Button 1	Terminals 2 + 3
Learned hand-held transmitter	-
Induction loop as safety input 1	Terminals 6 + 7

Drill template

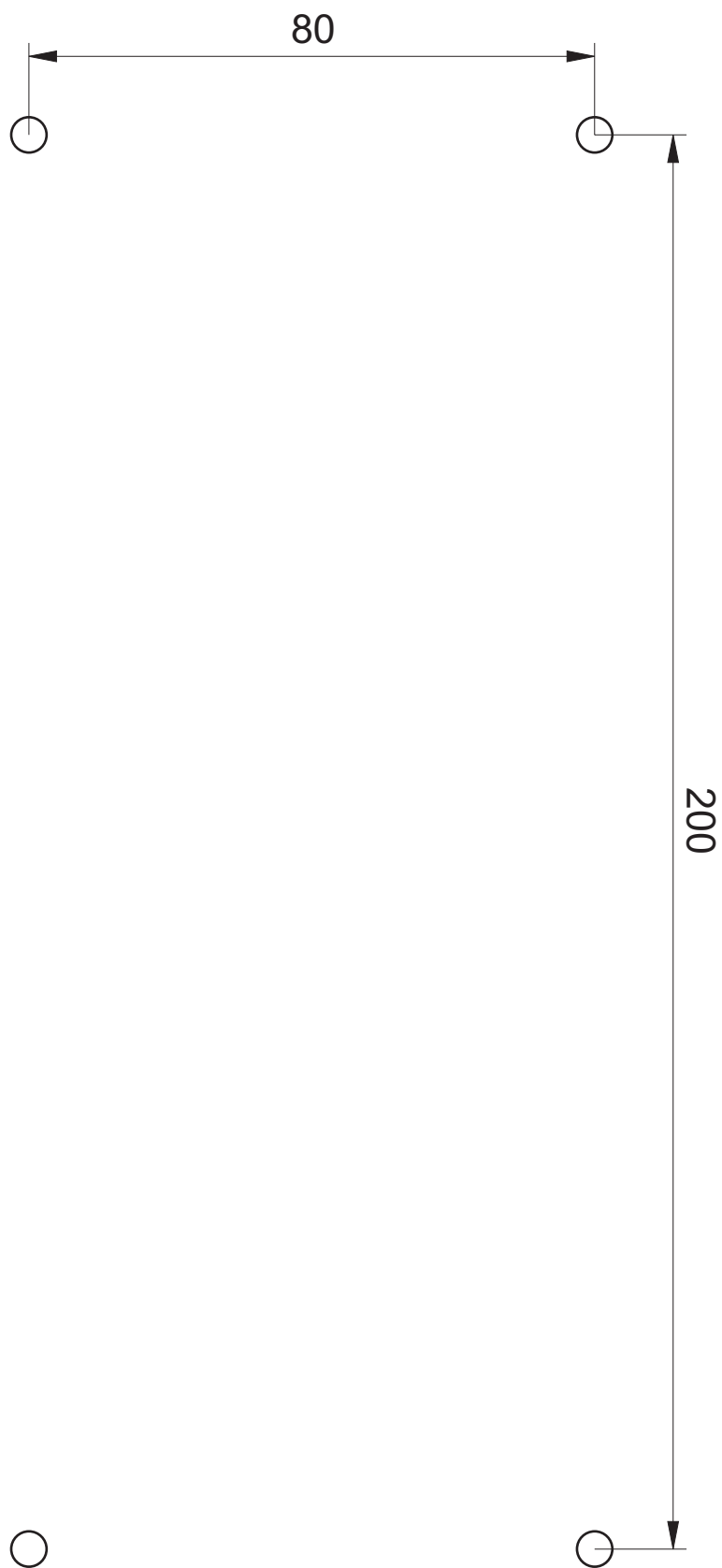

Barrier handover report

The following barrier and its accessories were properly installed and the settings desired by the customer were made. The signing customer has been trained in the operation and maintenance of the barrier and its accessories.

Type _____
Serial number _____
Handover date _____
Installation site _____ e.g. construction site of Sommer
_____ e.g. Hans-Böckler-Str. 21-27
_____ e.g. D-73230 Kirchheim/Teck

Adjustment of the barrier (DIP switch, Auto Time, etc.)

DIP 1	DIP 2	DIP 3	DIP 4	DIP 5	DIP 6	Auto Time

Accessories installed on the barrier (photo eye, command initiator, etc.)

Customer address

Company _____
Name of customer _____
Street, house number _____
Postal code, city _____

The barrier listed above and its accessories were properly installed by a fitter and handed over ready for operation. I have been trained in the operation, maintenance, and function of the safety devices. The safety measures have been explained to me. The complete installation and operating manual has been handed over in its entirety.

Date, customer's signature _____

Address of fitter's firm

Company _____
Name of fitter _____
Street, house number _____
Postal code, city _____

I have properly installed the barrier listed above and its accessories and handed it over ready for operation. I have trained the customer in the operation, maintenance, and function of the safety devices. The safety measures have been explained to the customer. The complete installation and operating manual has been handed over in its entirety.

Date, fitter's signature _____



Brief instructions

Emergency release

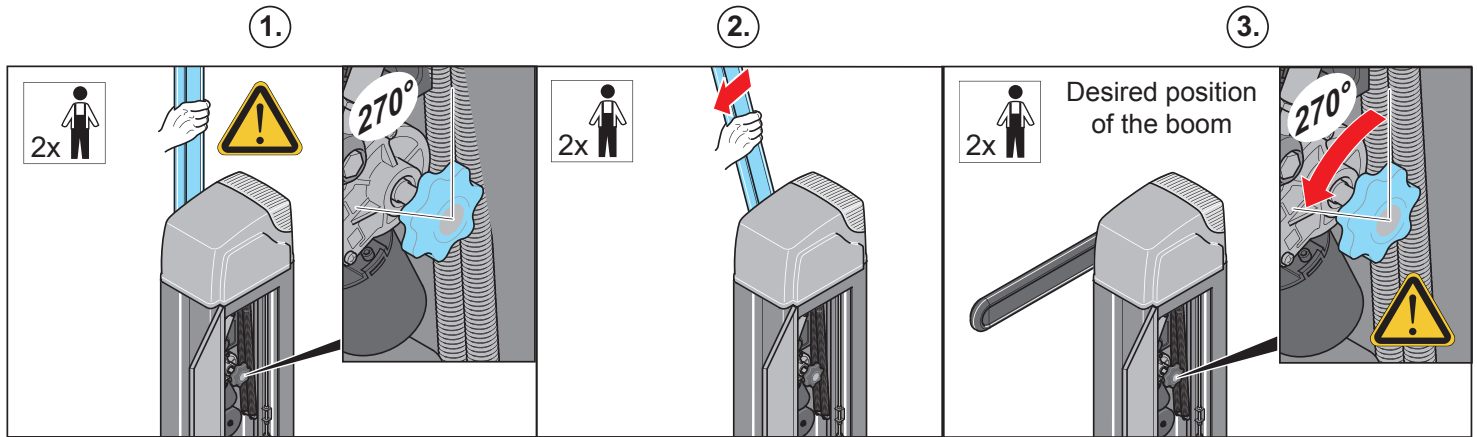

Resetting the control system

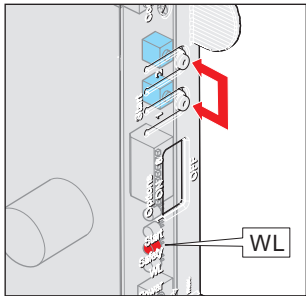

1. Press the buttons (1 + 2) until the "WL" LED extinguishes.
⇒ "WL" LED off - force values deleted.
2. Press the buttons (1+2).
3. Press the button (1).
⇒ The barrier closes.

Learning the force values

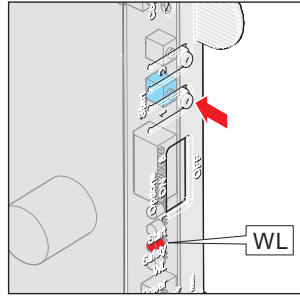

1. Press the button (1).
⇒ The barrier opens until the BARRIER OPEN end position is reached.
⇒ The "WL" LED flashes.
2. Press the button (1).
⇒ The barrier closes until the BARRIER CLOSED end position is reached.
⇒ The "WL" LED flashes.
3. Repeat Steps 1 and 2 three times.
⇒ The "WL" LED lights up and extinguishes - the force values have been learned.

Overview of the DIP switches

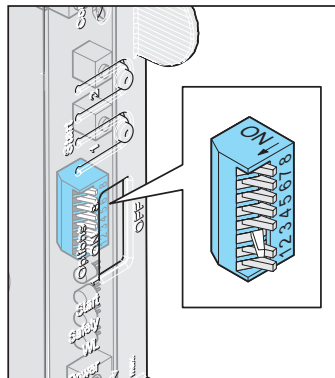

DIP switches	Position	Function/reaction
Obstacle detection during the opening of the barrier		
1	OFF	No reaction of the drive
	ON	The drive stops and closes the barrier completely
Selection of the safety device connected to safety input 1		
2	OFF	Selection of the NC contact
	ON	Selection of the safety contact strip
Obstacle detection during the closing of the barrier		
3	OFF	Impermissible setting
	ON	The drive stops and opens the barrier completely.
Close command due to safety input		
4	OFF	Deactivated
	ON	Activated
Prewarning time of the connected warning light		
5	OFF	Prewarning time 0 sec.
	ON	Prewarning time 3 sec. - warning light flashes
OSE system at safety input 1		
6	OFF	Deactivated, no OSE system connected
	ON	Activated, OSE system connected