

| REVISION RECORD | | | |
|-----------------|---------|-----------|-------|
| LTR | ECO NO. | APPROVED: | DATE: |
| | | | |
| | | | |
| | | | |

MT6573 V2.1 Phone w DDR1

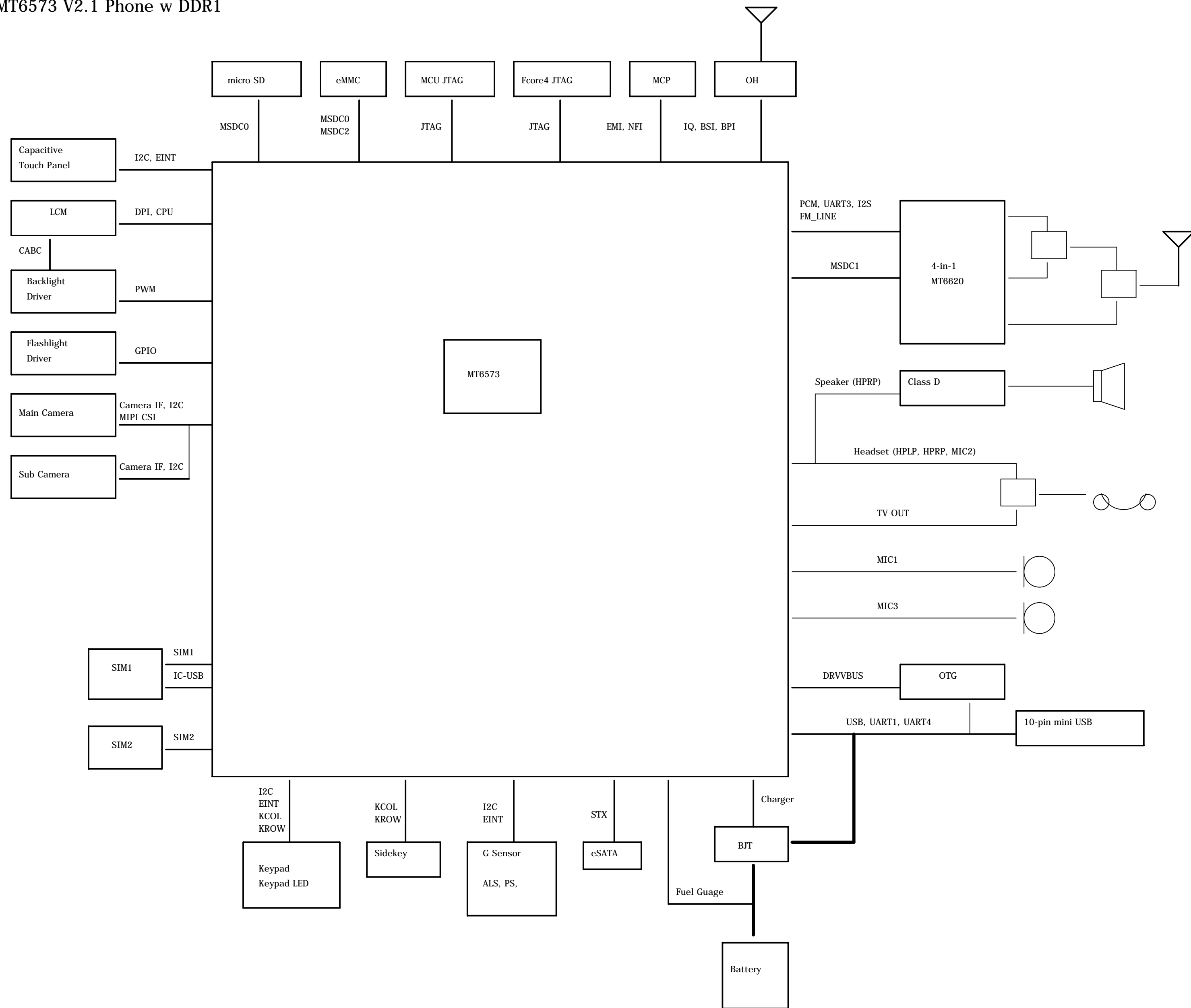

Check

A



| | | | | | | | |
|--------------------------|--|-----------------------|--|------------------------|---------|------------------------------|---------------|
| DRAWN: <Drawn By> | | DATED: 2011-01-28 | | COMPANY: LENOVO MOBILE | | | |
| CHECKED: <Checked By> | | DATED: <Checked Date> | | TITLE: Avatar_MB_H101 | | | |
| QUALITY CONTROL: <QC By> | | DATED: <QC Date> | | CODE: <Code> | SIZE: D | DRAWING NO: 01_BLOCK_DIAGRAM | REV: V4.1 |
| RELEASED: <Released By> | | DATED: <Release Date> | | SCALE: <Scale> | | | SHEET: 10F 10 |

| REVISION RECORD | | | |
|-----------------|---------|-----------|-------|
| LTR | ECO NO. | APPROVED: | DATE: |
| | | | |
| | | | |
| | | | |

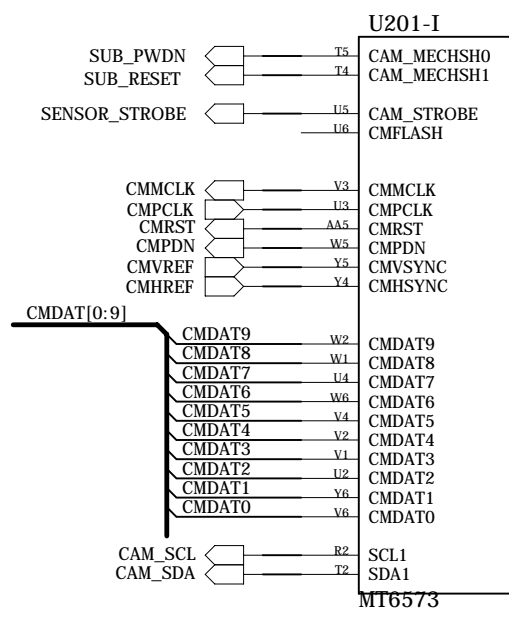

Note: AFC > 3G_TX_VGA > AFC > 3G_VBIAS

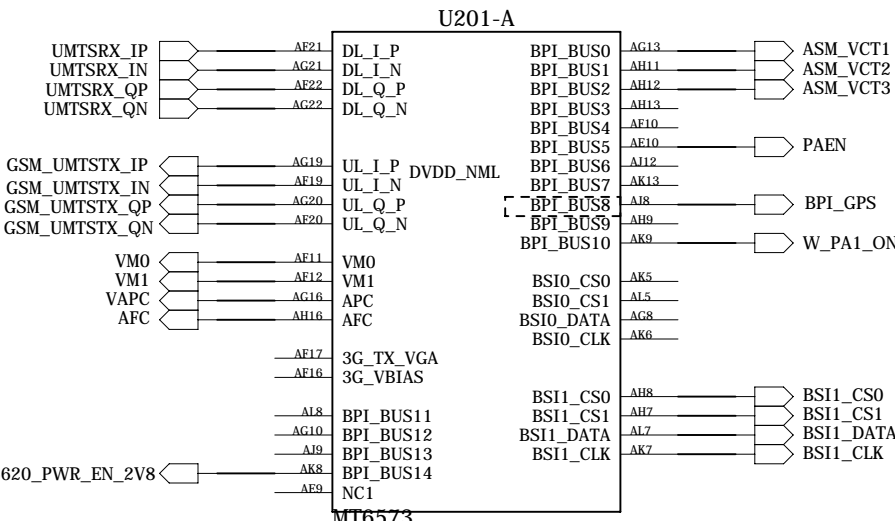

* MT6573 Camera *

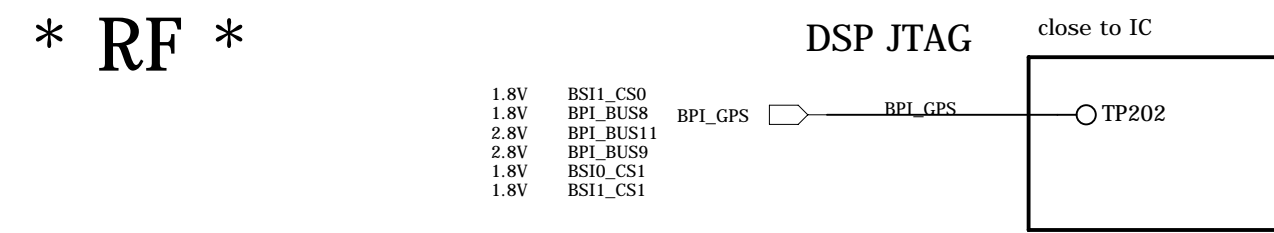

* TEST POINT *

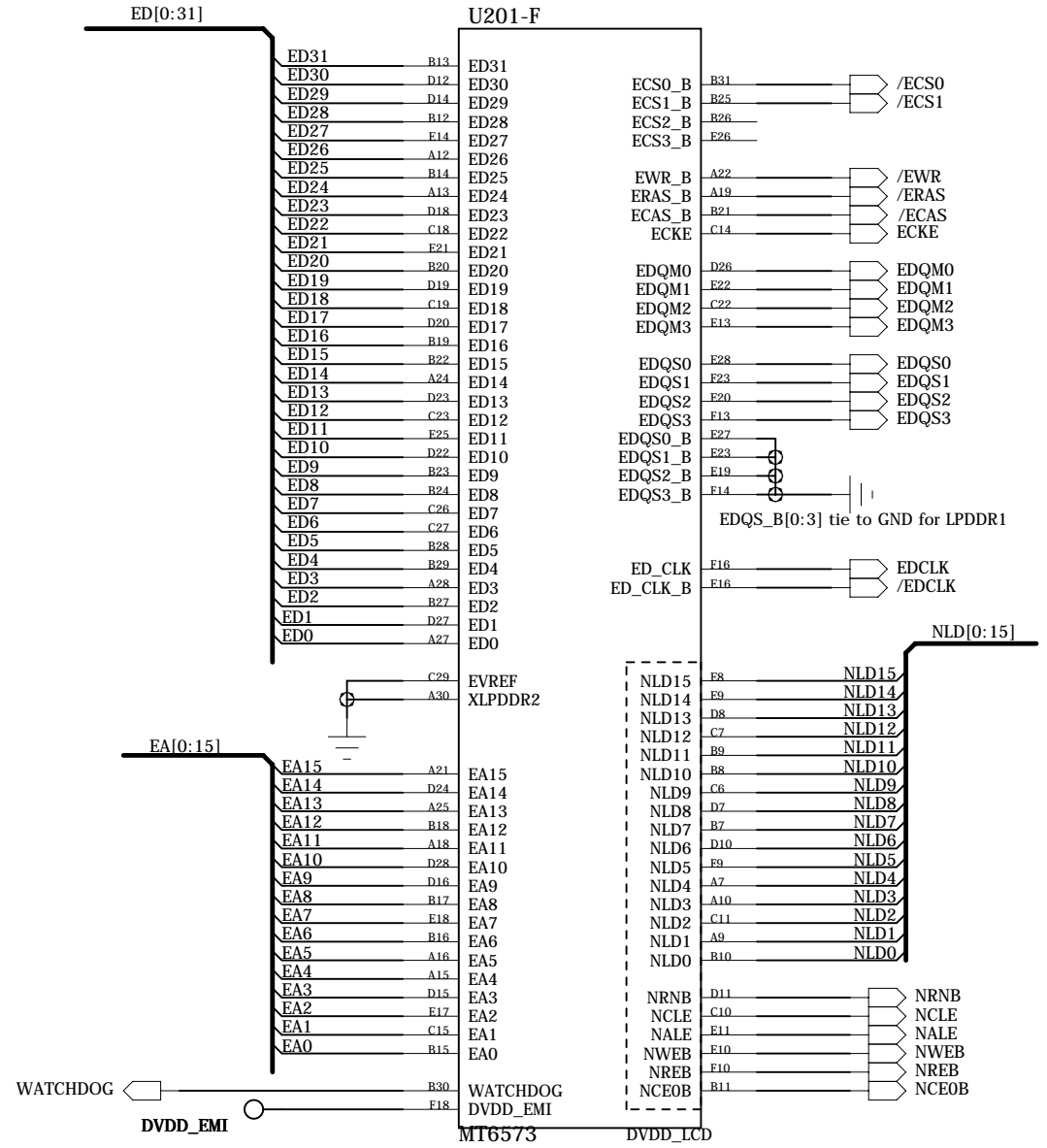

* MT6573 EMI *

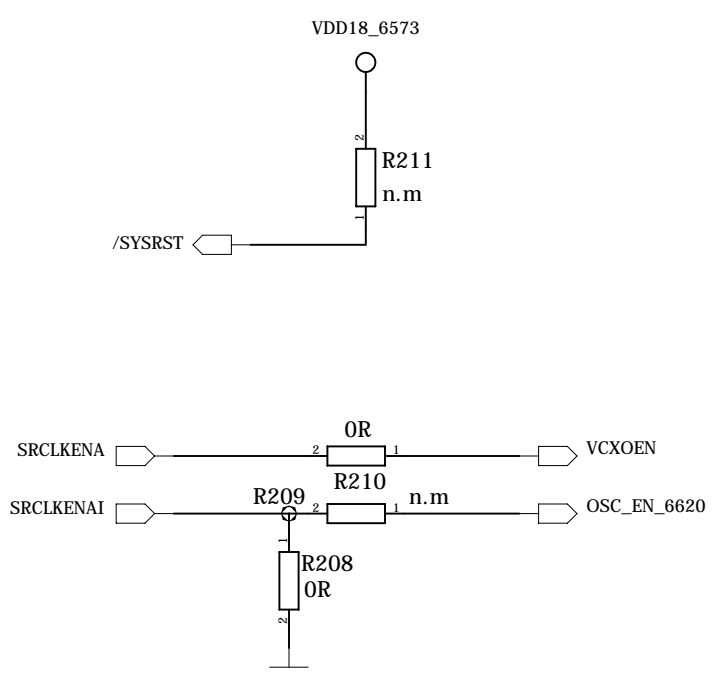

Note: tied together (1.8V or 2.8V)

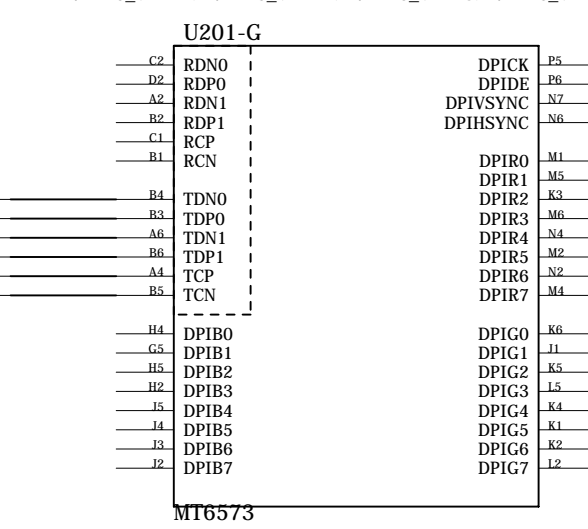

* MT6573 LCD INTERFACE *

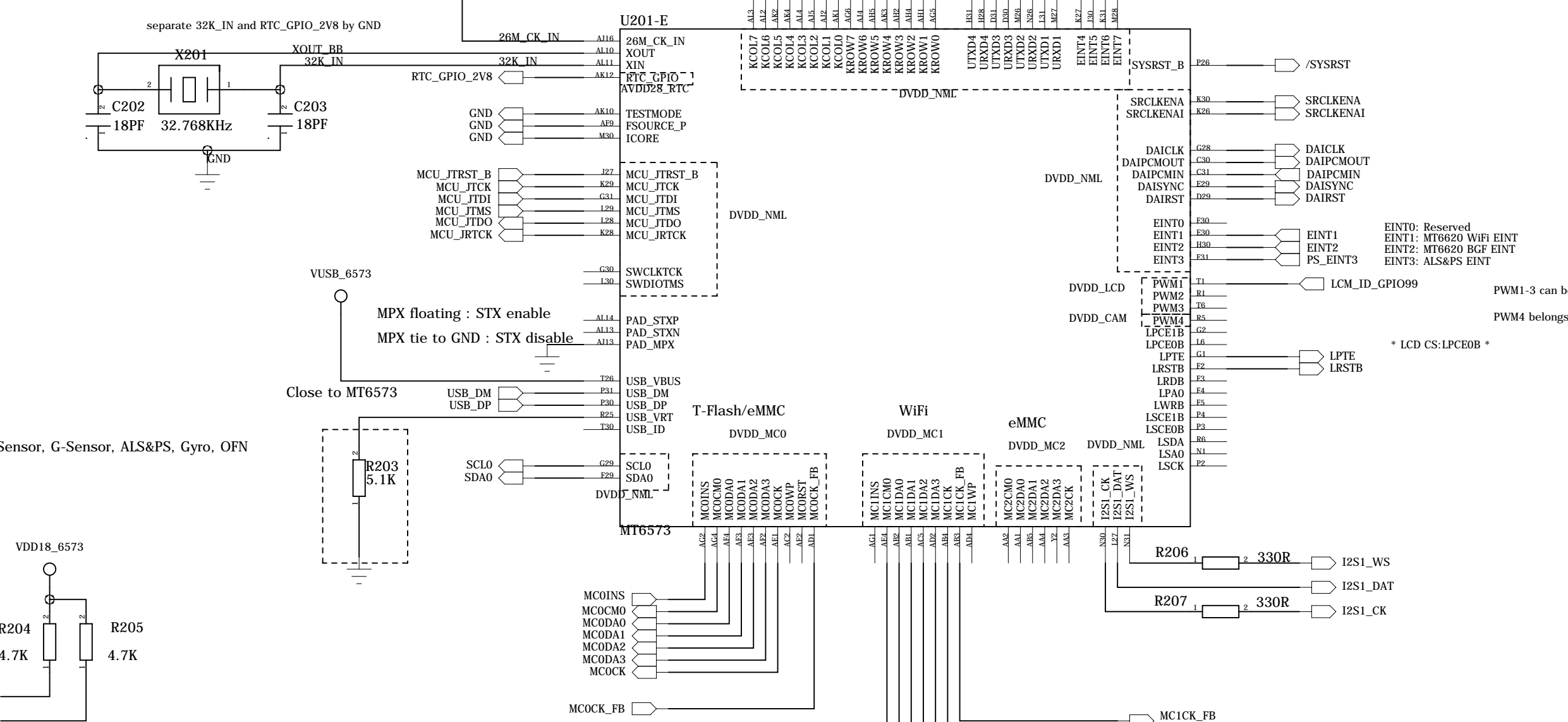
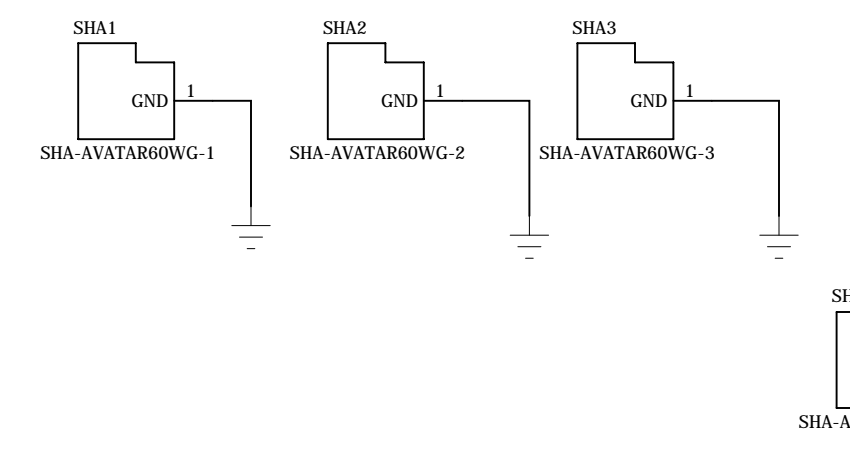

Trace32 (under the battery)

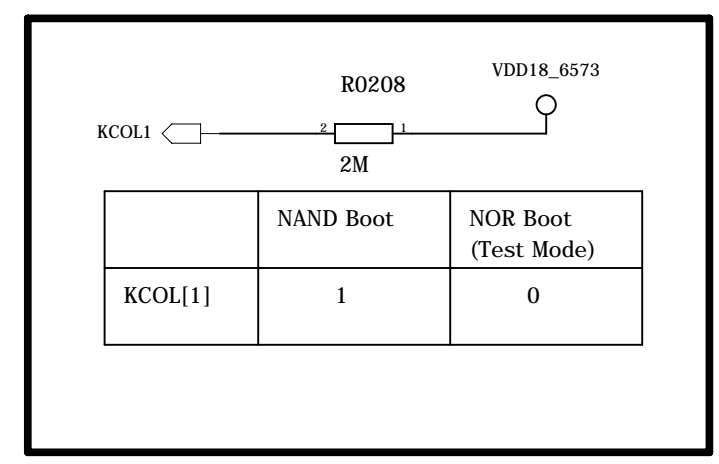
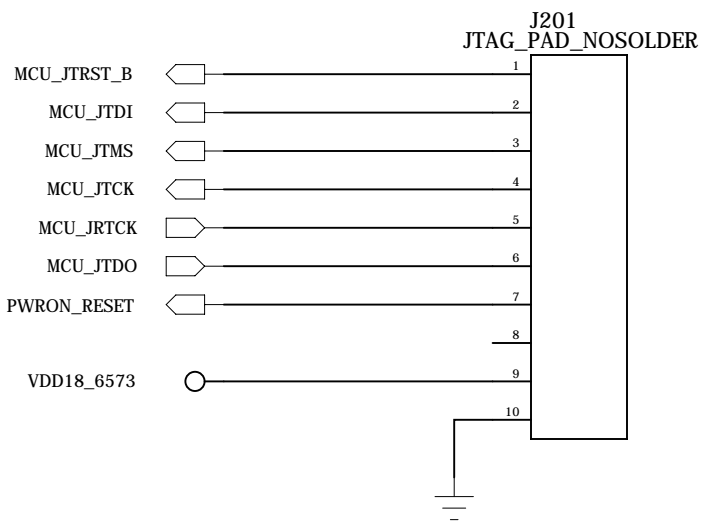

| | | | |
|--------------------------|--------------|-----------------------|-------------|
| DRAWN: <Drawn By> | | DATED: 2011-01-28 | |
| CHECKED: <Checked By> | | DATED: <Checked Date> | |
| QUALITY CONTROL: <QC By> | | DATED: <QC Date> | |
| RELEASED: <Released By> | | DATED: <Release Date> | |
| CODE: <Code> | SIZE: <Code> | DRAWING NO: <Code> | REV: <Code> |
| SCALE: <Scale> | | SHEET: 2 of 10 | |

| | |
|------------------------|--|
| COMPANY: LENOVO MOBILE | |
| TITLE: Avatar_MB_H101 | |
| D02_MT6573_- BASEBAND | |



| REVISION RECORD | | | |
|-----------------|---------|-----------|-------|
| LTR | ECO NO: | APPROVED: | DATE: |
| | | | |
| | | | |
| | | | |

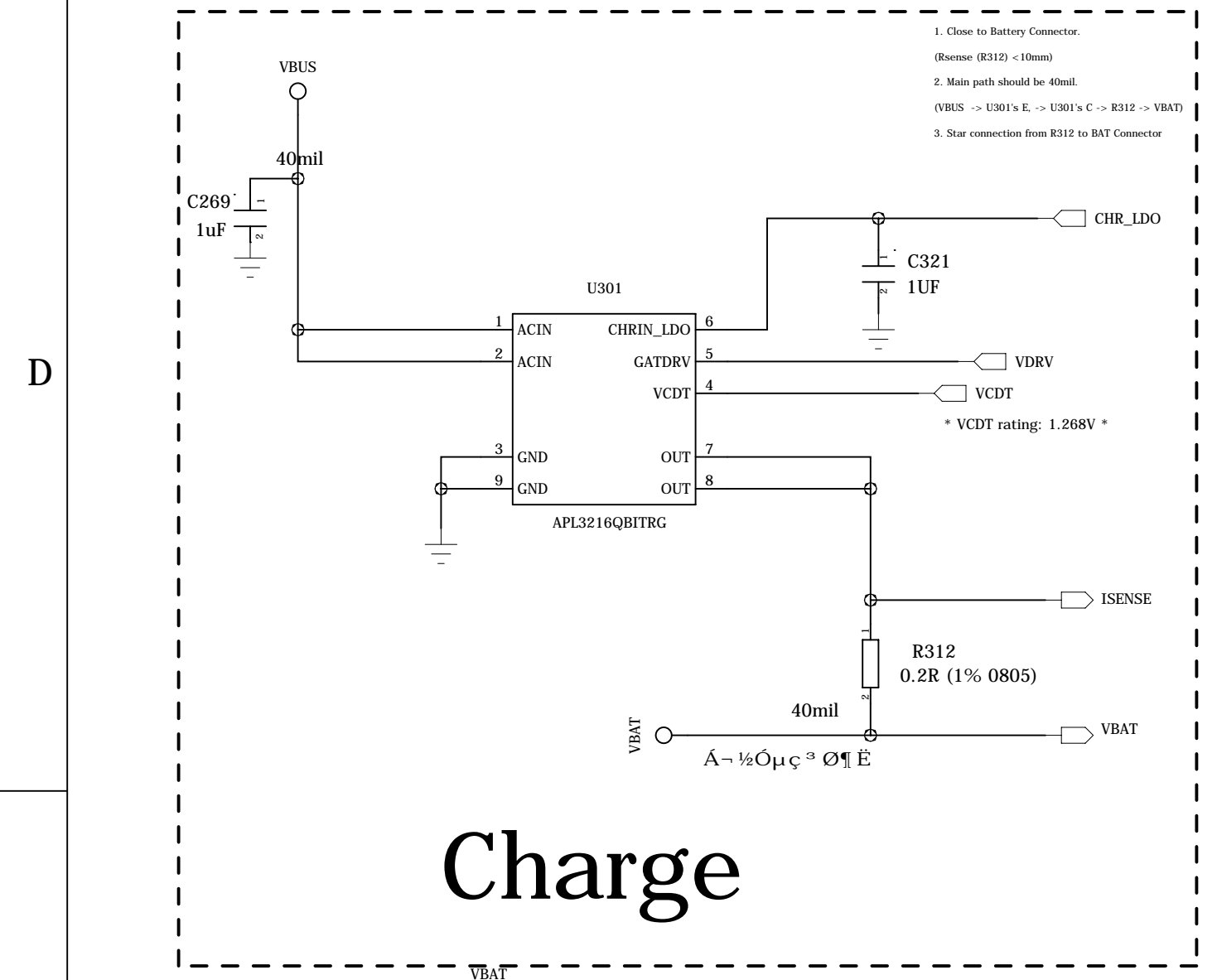

Charge

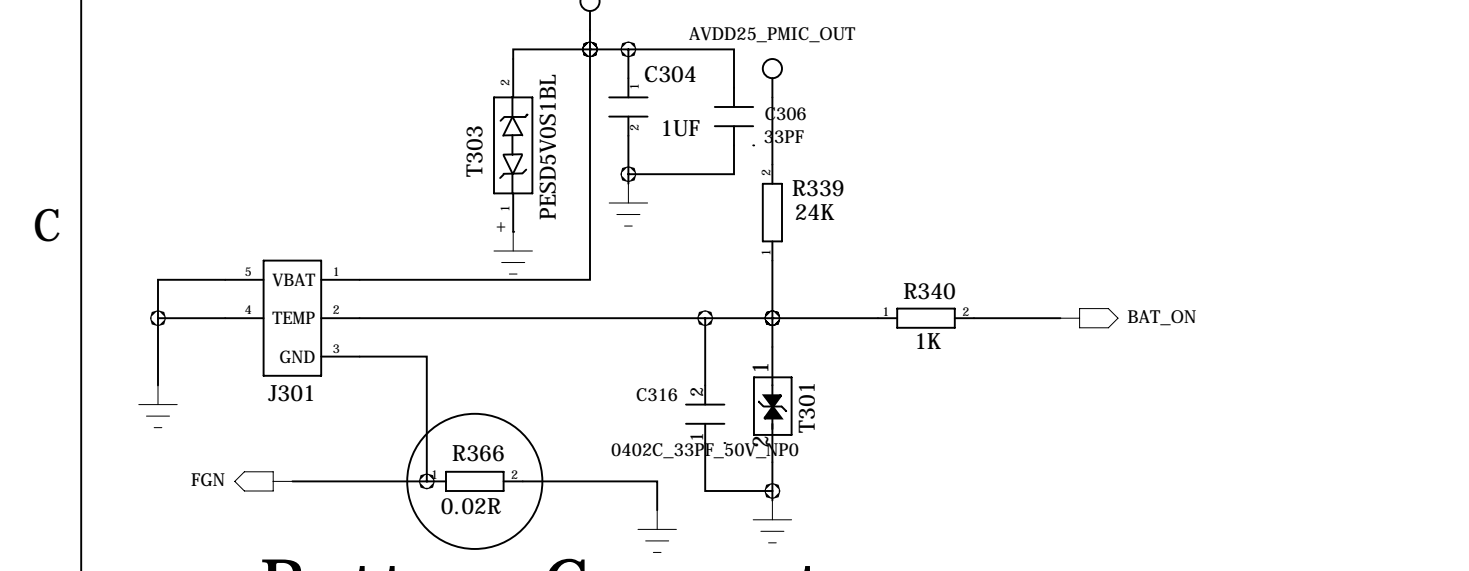

Battery Connector

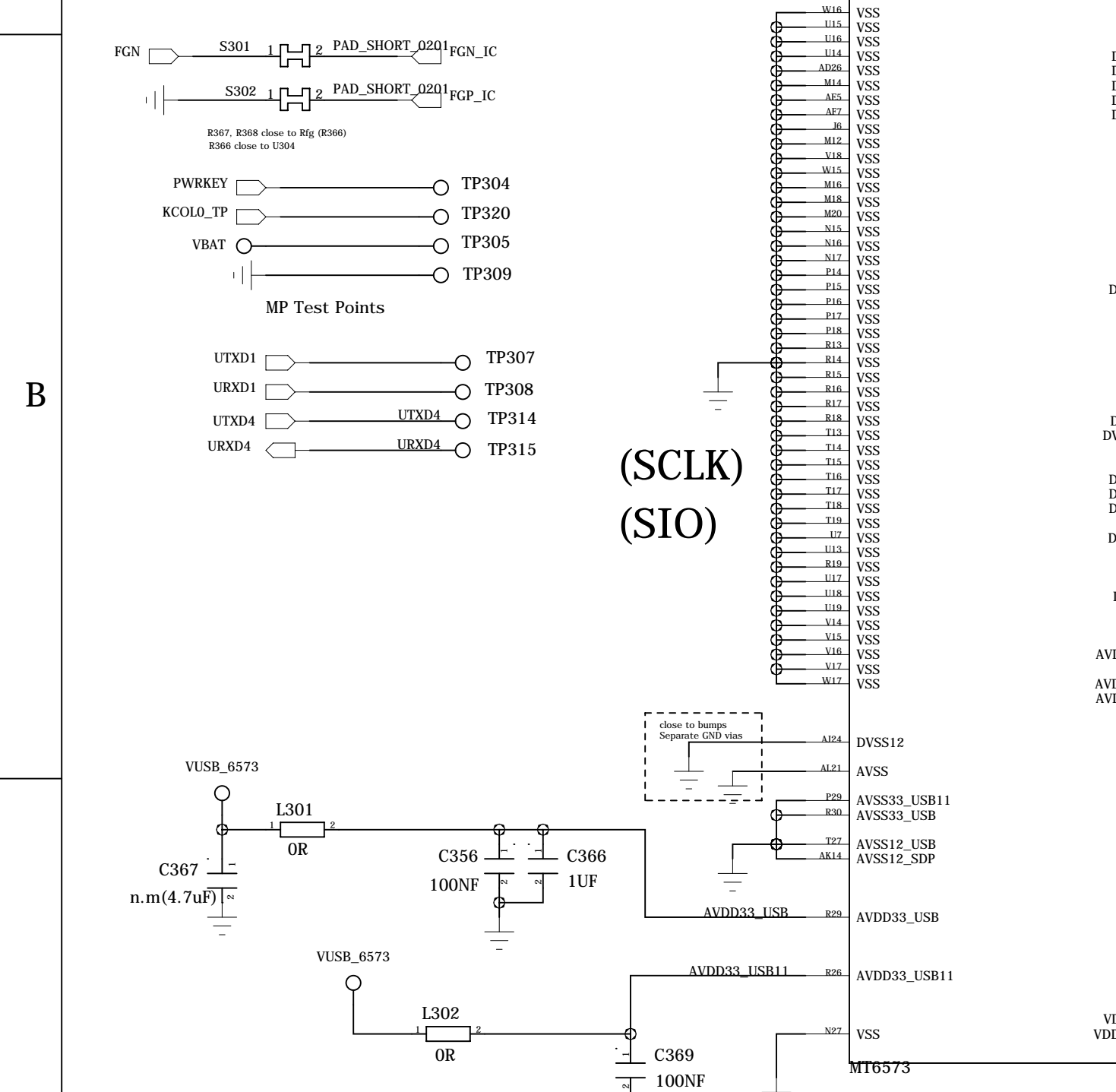

Add Zener Diode
 Place on the path
 from VBAT to IC
 (Battery connector
 or test point or IO
 connector)

Between IC and IO port

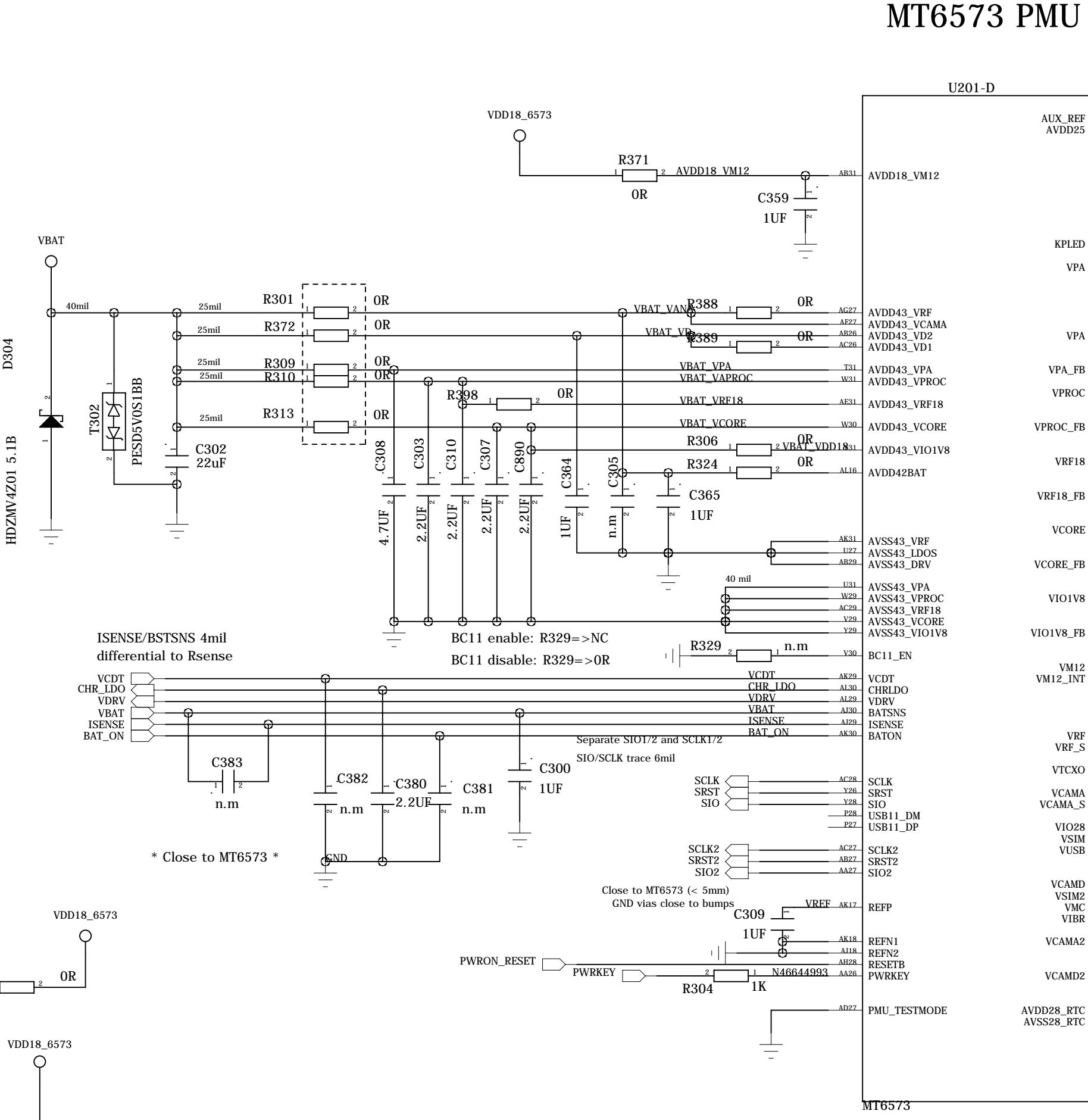

| REVISION RECORD | | | |
|-----------------|---------|----------|------|
| Q/R | ECO NO. | APPROVED | DATE |
| | | | |
| | | | |
| | | | |

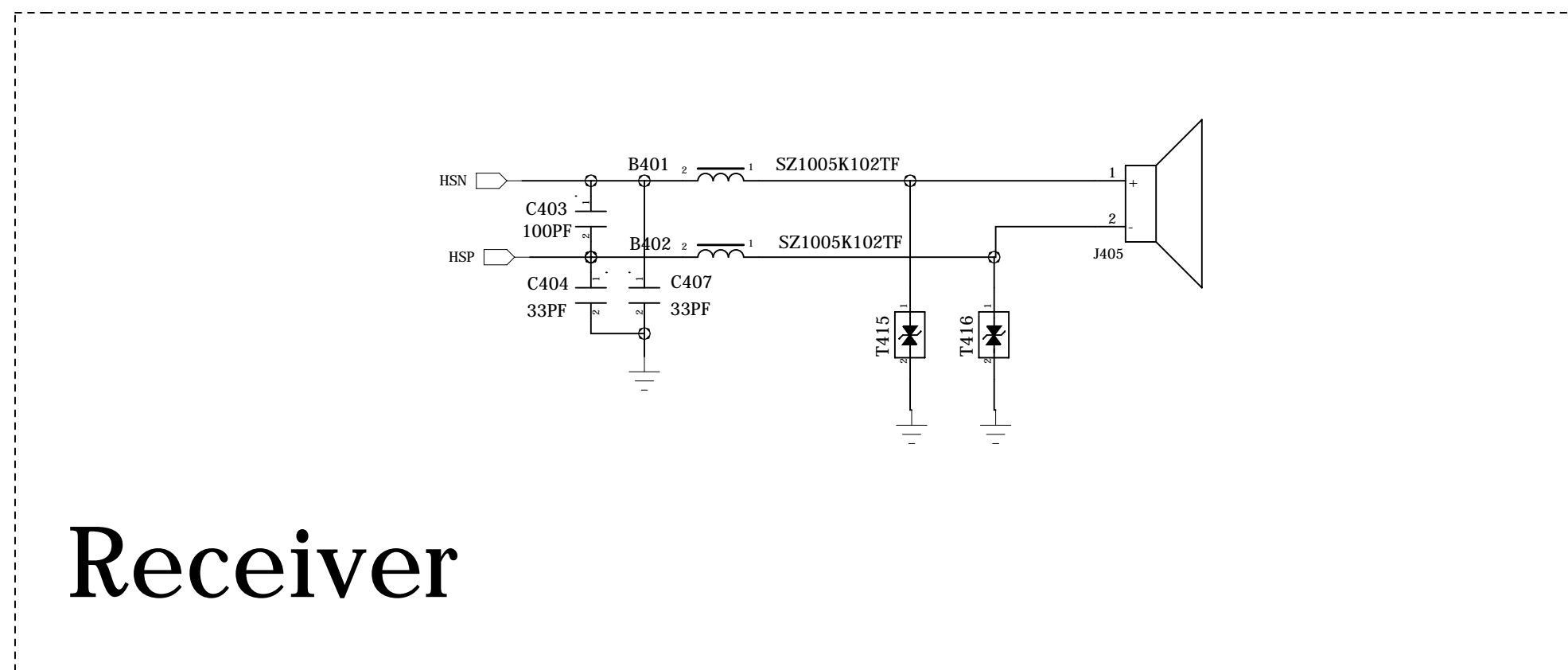
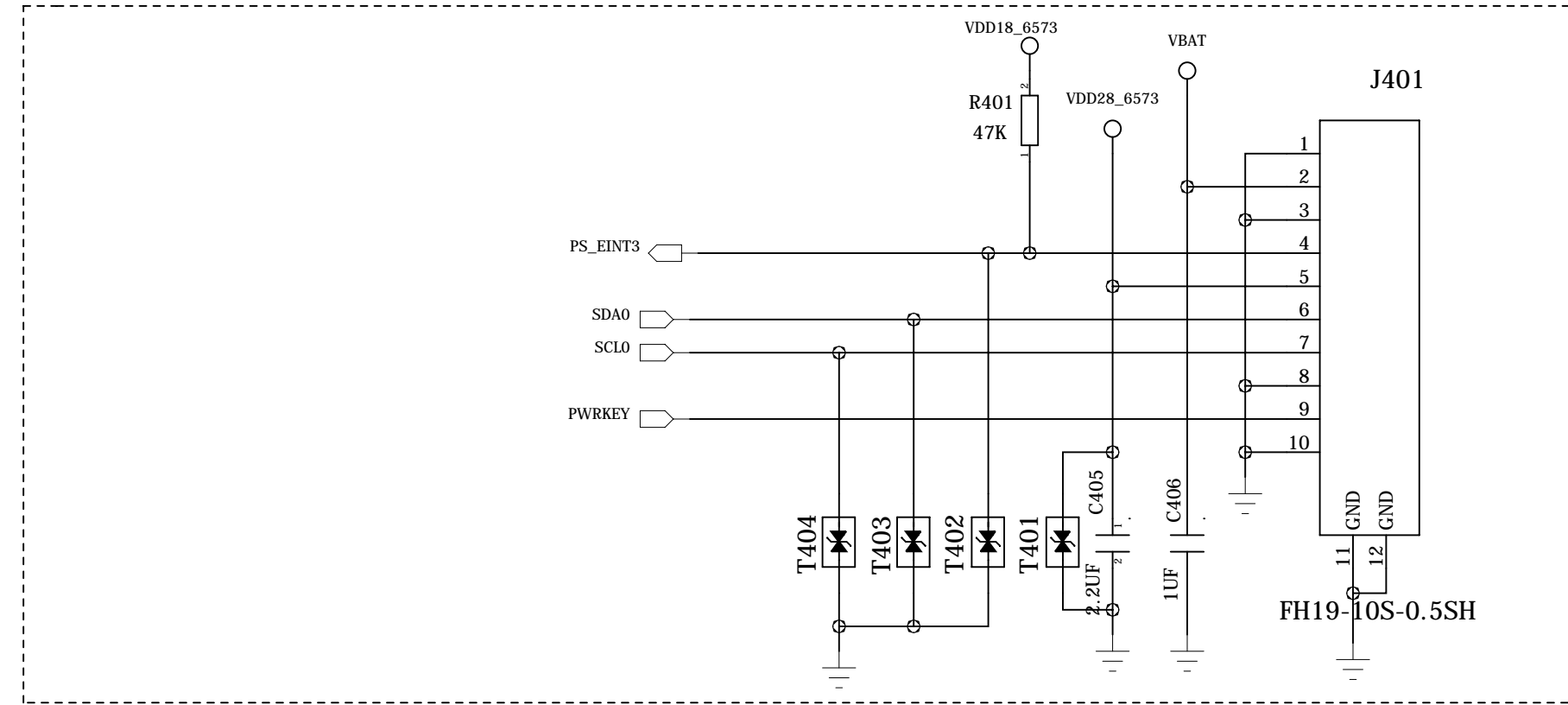
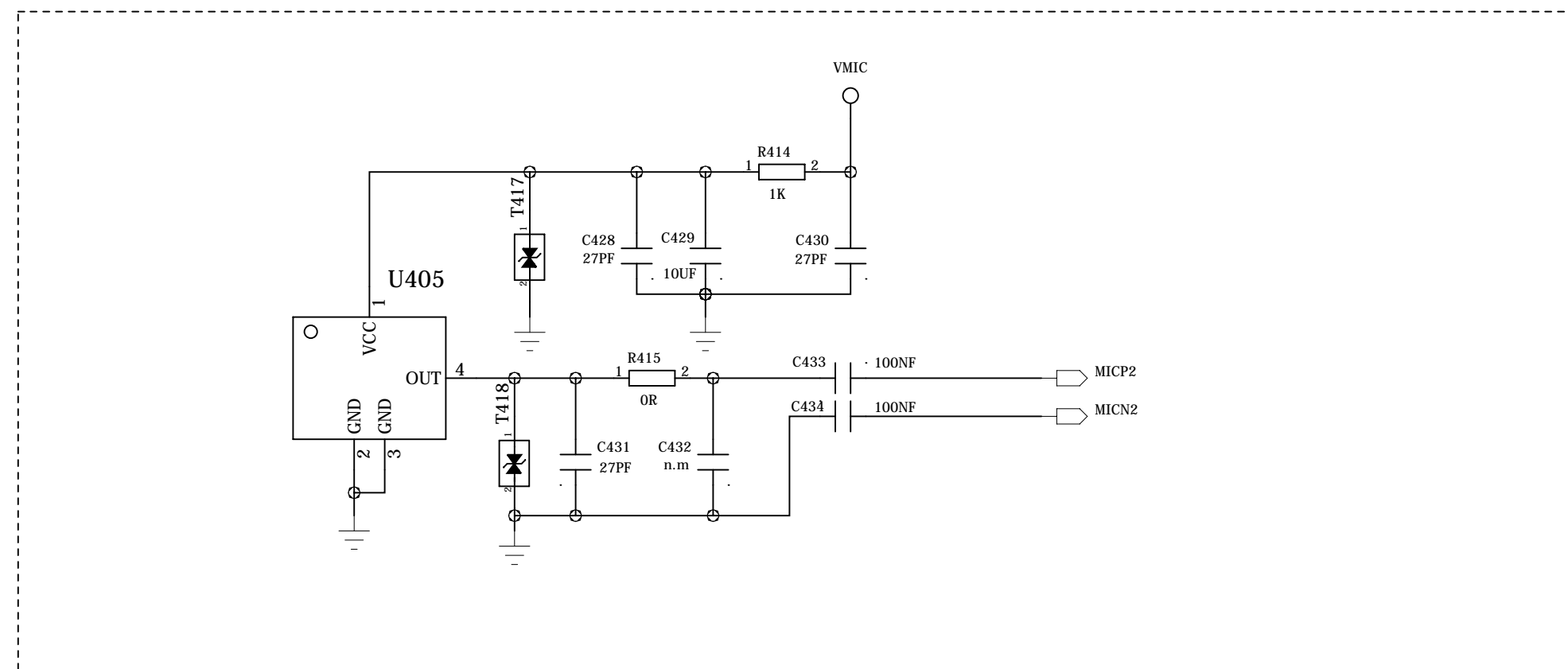

Receiver

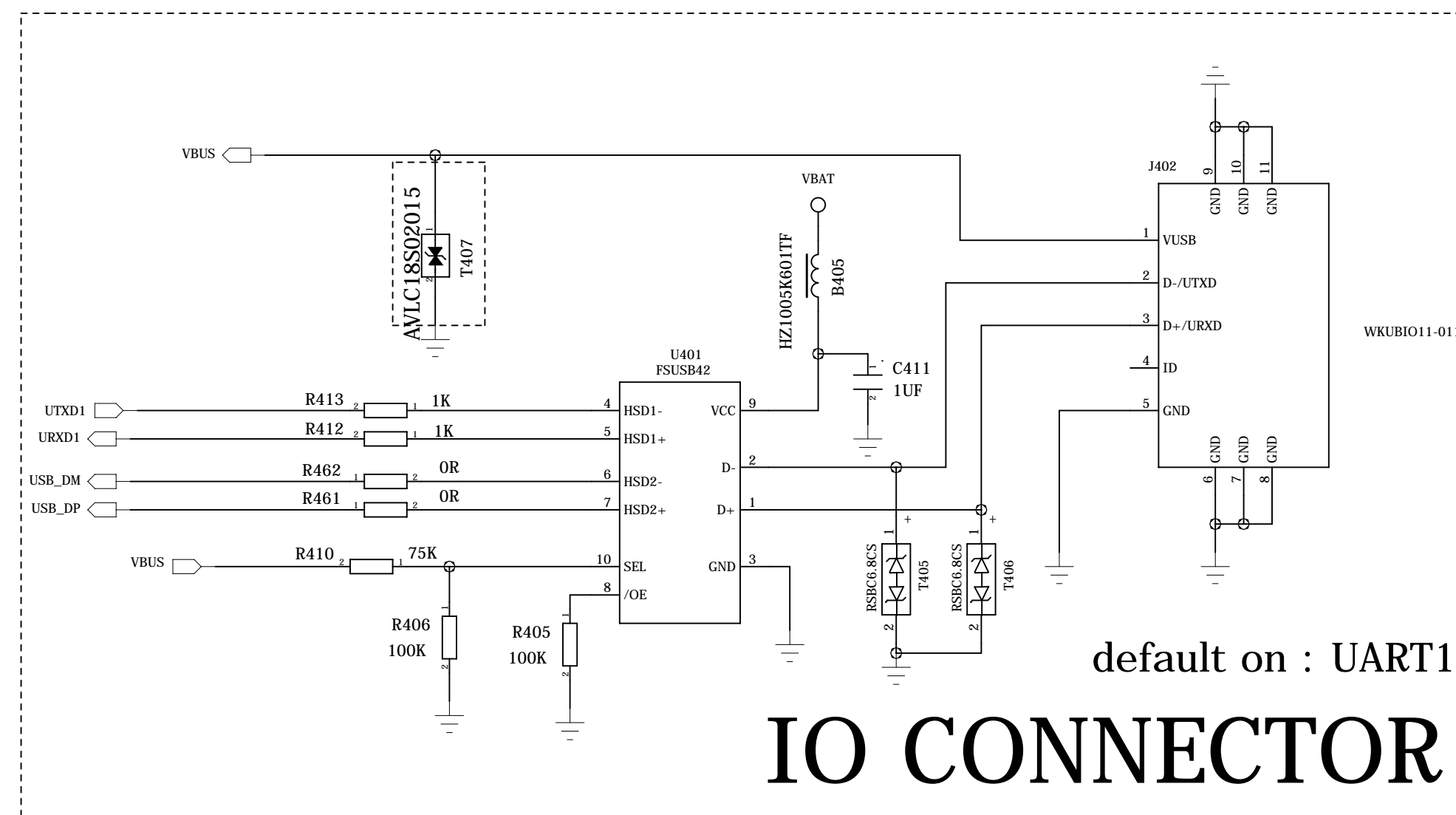
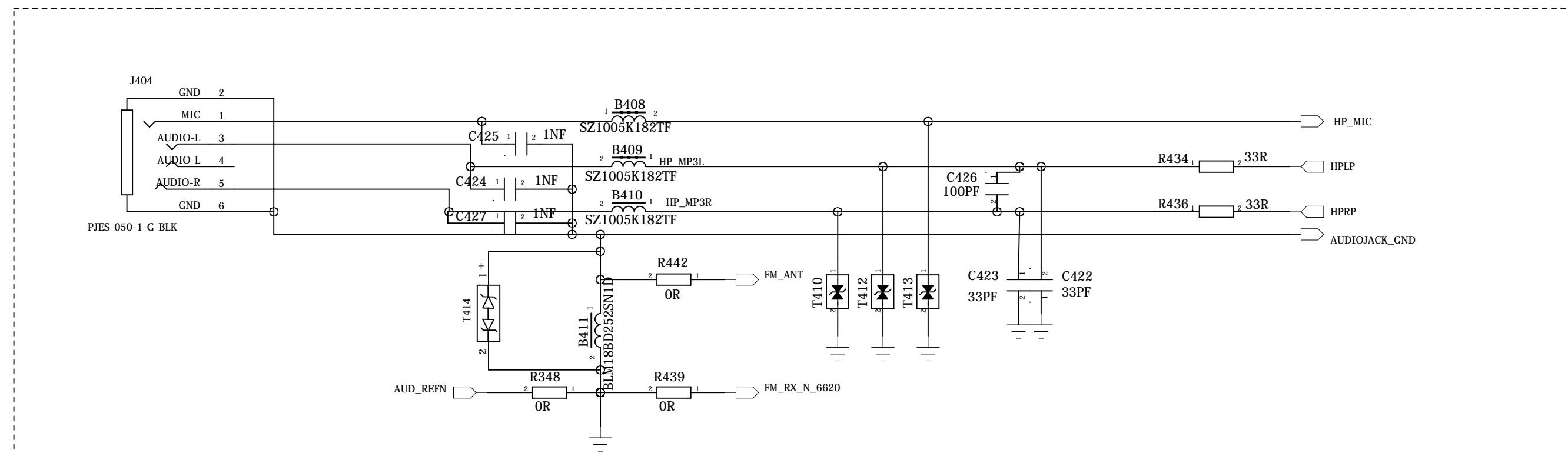

default on : UART1
IO CONNECTOR

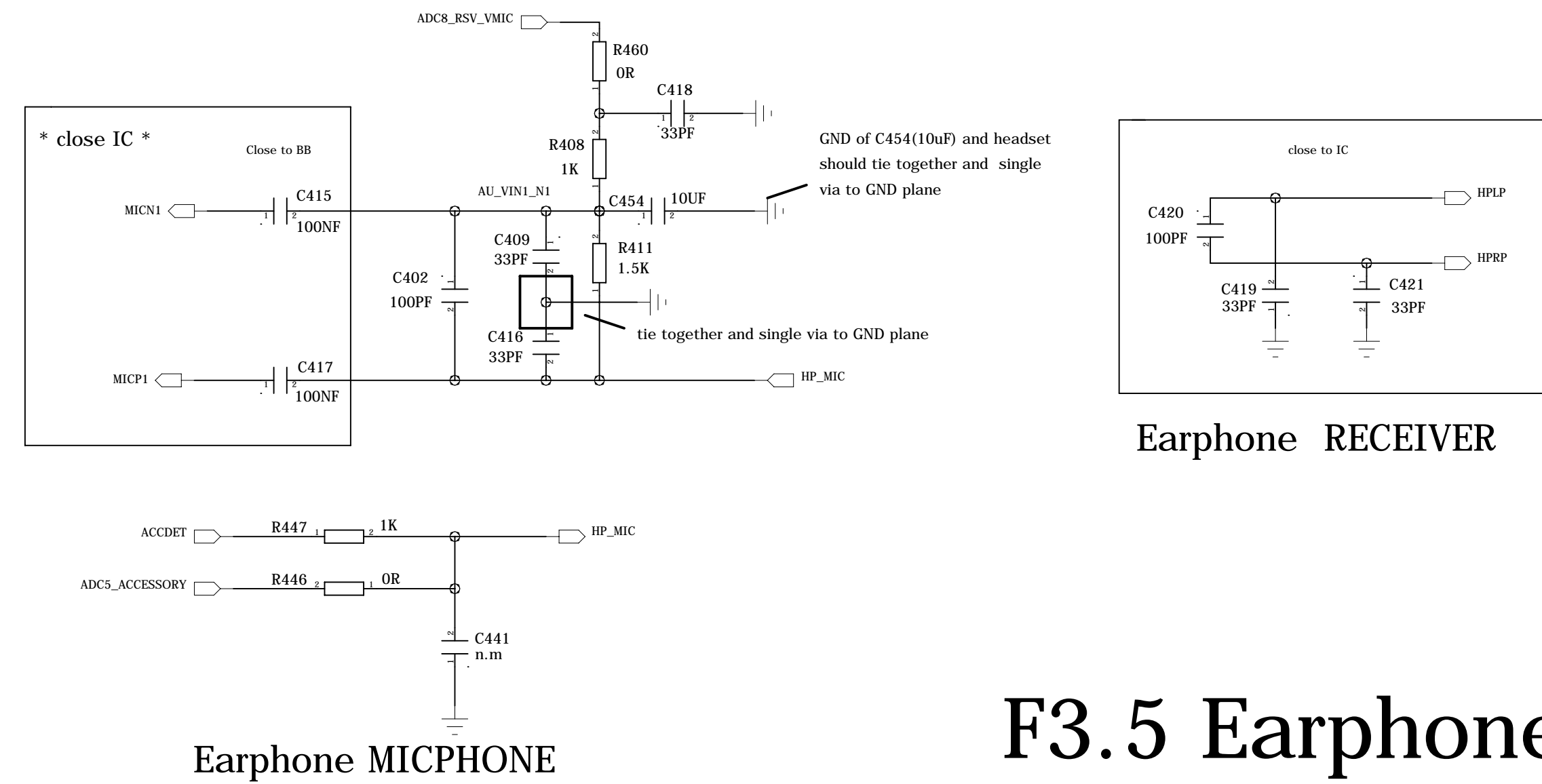

F3.5 Earphone

D

D

C

C

B

B

A

A



| | | | |
|--------------------------|-----------------------|-----------------------------------|---------------|
| COMPANY: LENOVMOBILE | | | |
| TITLE: Avatar_MB_H101 | | | |
| DRAWN: <Drawn By> | DATED: 2011-01-28 | CODE: <Code> | SIZE: D |
| CHECKED: <Checked By> | DATED: <Checked Date> | DRAWING NO: 04_AUDIO_I/O_USB V4.1 | REV: <Rev> |
| QUALITY CONTROL: <QC By> | DATED: <QC Date> | SCALE: <Scale> | SHEET: 4of 10 |
| RELEASED: <Released By> | DATED: <Release Date> | | |

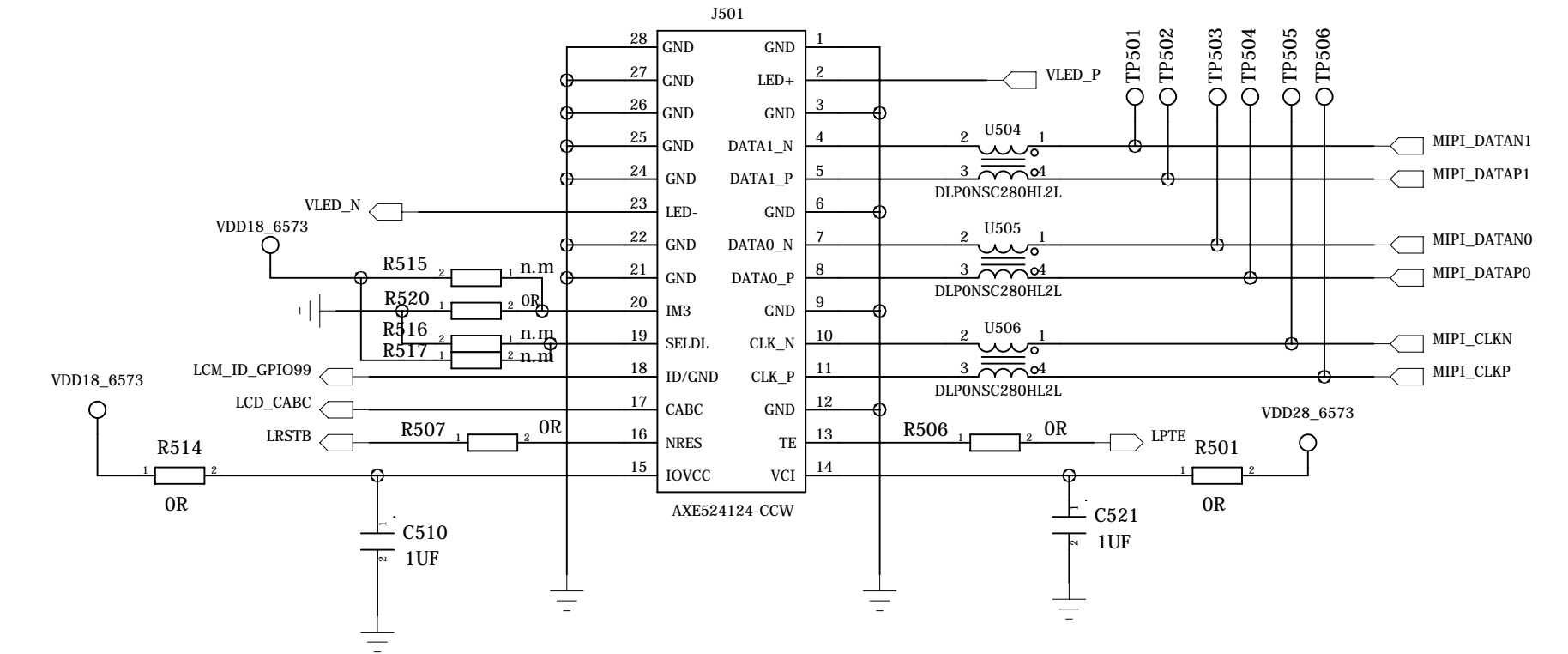

LCM

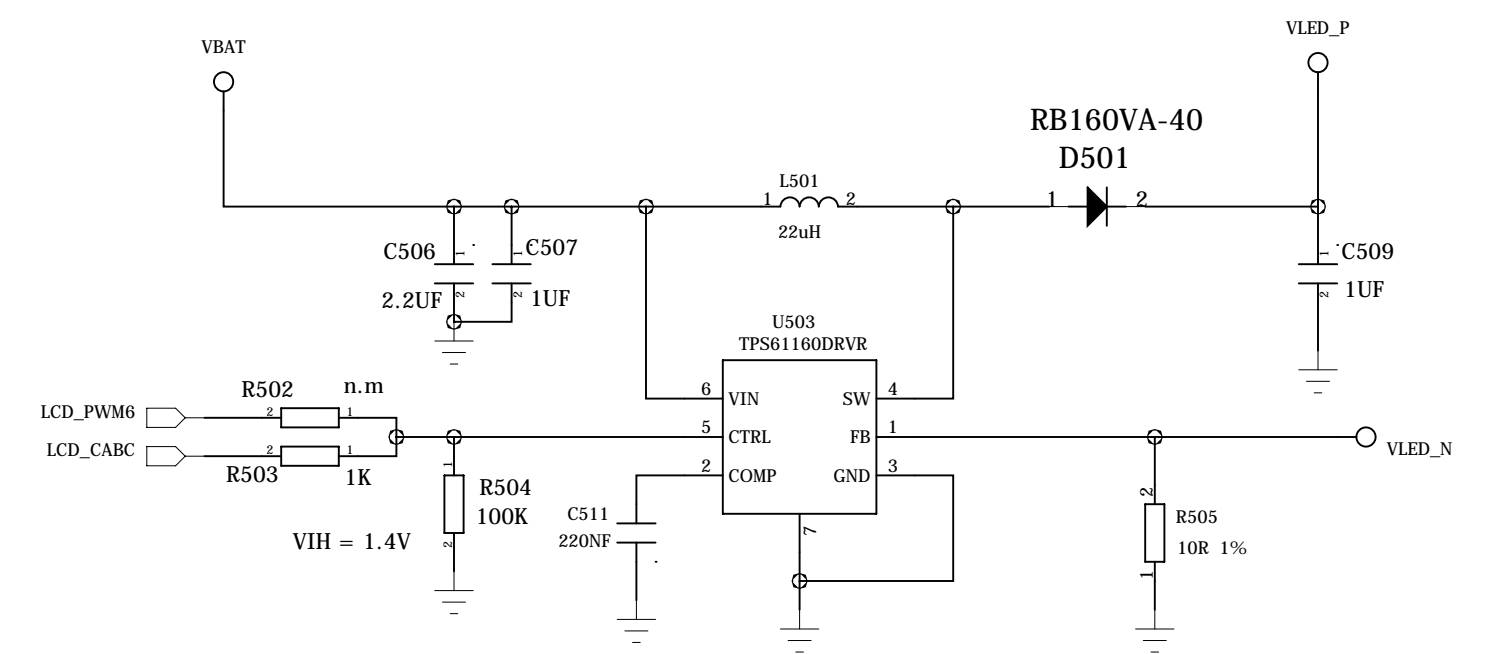

LCD BACKLIGHT

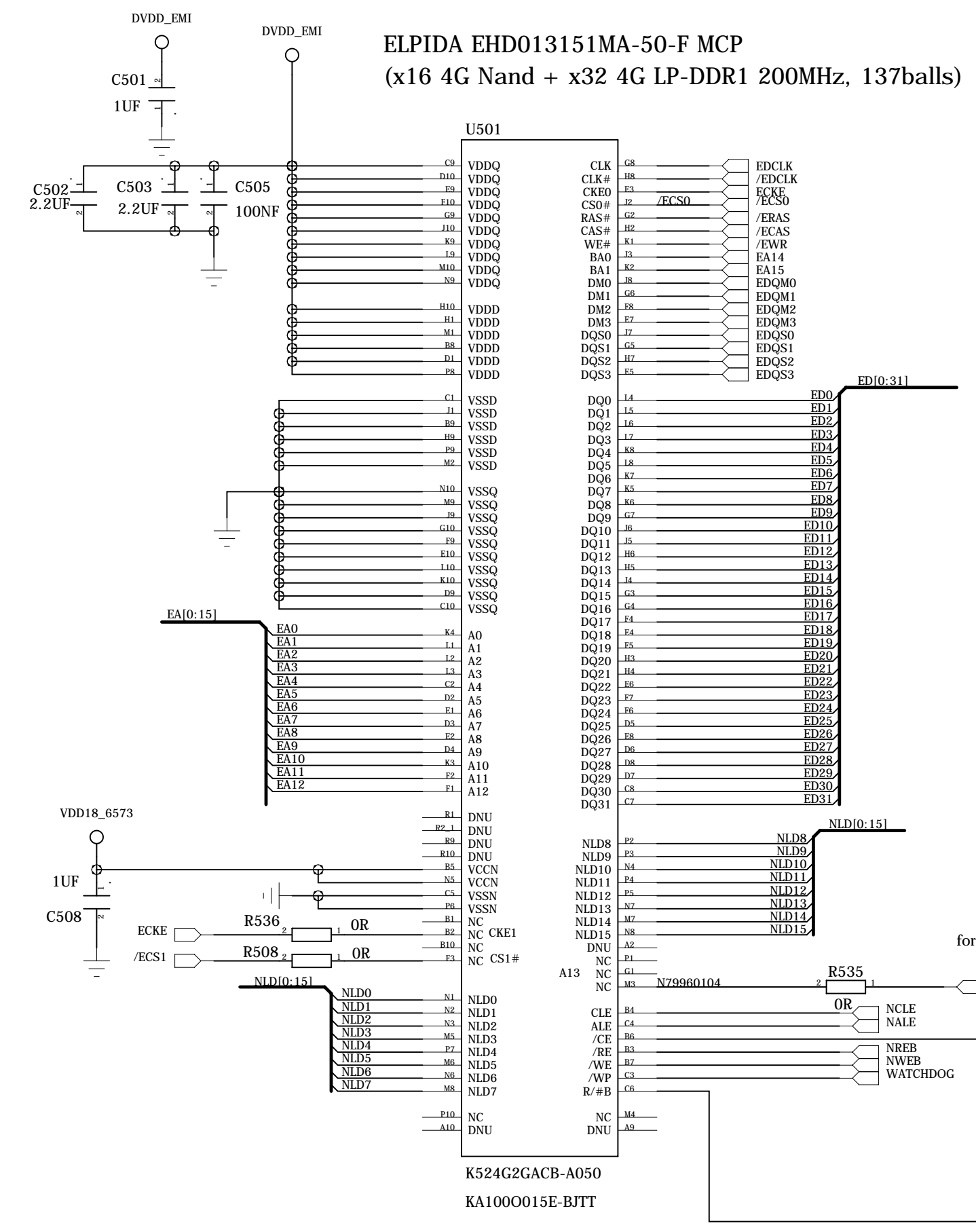

| | | | | | |
|-----------------------------|----------------------|----------------|-------|---------------|------|
| COMPANY: | | LENOVOMOBILE | | | |
| TITLE: | | Avatar_MB_H101 | | | |
| DRAWN: <Drawn By> | DATED: 2011-01-28 | CODE: | SIZE: | DRAWING NO: | REV: |
| CHECKED: | <Checked Date> | <Code> | D | 05_MEMORY/LCD | V4.1 |
| QUALITY CONTROL: <QC By> | DATED: <QC Date> | SCALE: <Scale> | | SHEET: 5OF 10 | |
| RELEASED: | DATED: | | | | |

| REVISION RECORD | | | |
|-----------------|---------|-----------|-------|
| LTR | ECO NO: | APPROVED: | DATE: |
| | | | |
| | | | |
| | | | |

RF_MT6162_RX

7/7 Add matching components and Use RFWS matching circuit

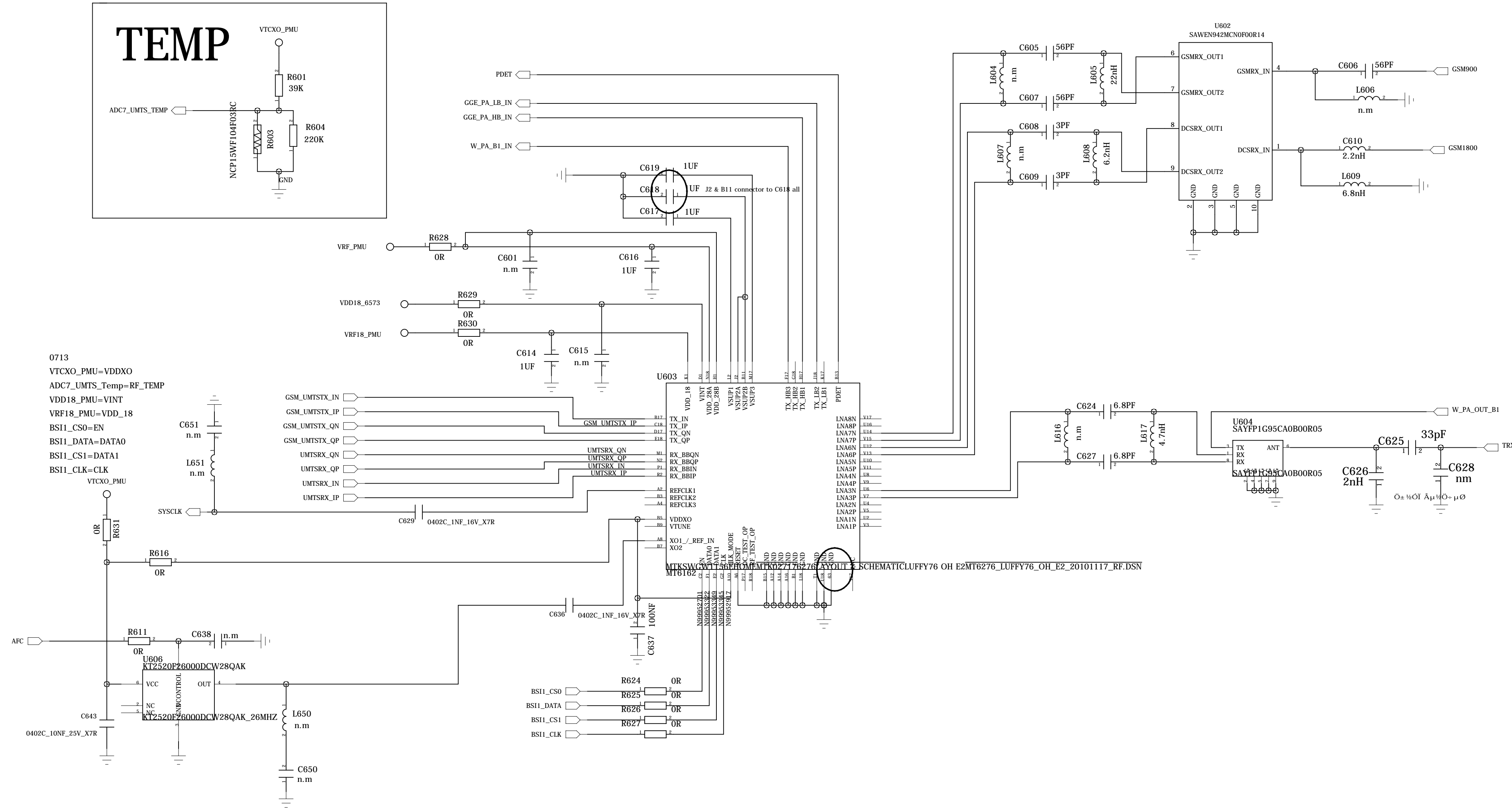

0713
 VTCXO_PMU=VDDXO
 ADC7_UMTS_Temp=RF_TEMP
 VDD18_PMU=VINT
 VRF18_PMU=VDD_18
 BS11_CS0=EN
 BS11_DATA=DATA0
 BS11_CS1=DATA1
 BS11_CLK=CLK
 VTCXO_PMU

- 1117 Update Note
1. Change U603 Footprint to MT6162/AQFN62/P0.333/B0.27/6.2X6.2
 2. Change U603 GND_PIN from Pin1 to Pin63
 3. Add B2 Common Mode trap
 4. VDD_28 change to VRF_PMU
 5. Remove R605
 6. Add R616, R631, R632 0201 Short 0ohm for Current Measure
 7. C614, C616 from NM change to 1uF
 8. VBAT in RF change to VBAT_RF, add 0805 0ohm
 9. VTCXO_PMU add LDO

- 1007 Update for sens
1. B8
 2. B2 use B7955, C639, C642 from 8.2pF to 6.8pF, L621 from 5.6nH to 6.8nH, C641 from 3.6nH to 15nH
 3. B1
 4. DCS
 5. C624 and C627 from 8.2pF to 6.8pF, C625 from 1.2nH to 1.1nH
 6. C608, C609 from 39pF to 3pF



| | | | | | |
|------------------|---------------|-----------------|----------------|--|--|
| COMPANY: | | LENOVOMOBILE | | | |
| TITLE: | | Avatar_MB_H101 | | | |
| DRAWN: | YEXL | DATED: | 2011-01-28 | | |
| CHECKED: | | DATED: | | | |
| QUALITY CONTROL: | <QC By> | DATED: | <QC Date> | | |
| RELEASED: | <Released By> | DATED: | <Release Date> | | |
| CODE: | SIZE: | DRAWING NO.: | REV: | | |
| <Code> | D | 06_RF_MT6162_RX | V4.1 | | |
| SCALE: | <Scale> | | SHEET: 6 of 10 | | |

| REVISION RECORD | | | |
|-----------------|---------|-----------|-------|
| LTR | ECO NO: | APPROVED: | DATE: |
| | | | |
| | | | |
| | | | |

0713 Update Net Name
 ADC6_UMTS_POWER =GGE_PA_VDET
 EDGE_MODE =GGE_PA_MODE
 ADC6_UMTS_POWER =GGE_PA_VDET
 VAPC =GGE_PA_VRAMP
 BANDSW =GGE_PA_BS
 PAEN =GGE_PA_ENABLE

 VM1 =W_PA_VMODE1
 VM0 =W_PA_VMODE0
 W_PA5_ON =W_PA_B5_EN
 W_PA8_ON =W_PA_B8_EN
 W_PA1_ON =W_PA_B1_EN
 W_PA2_ON =W_PA_B2_EN

RF_TX_ASM

1. VBAT in RF change to VBAT_RF, add 0805 0ohm

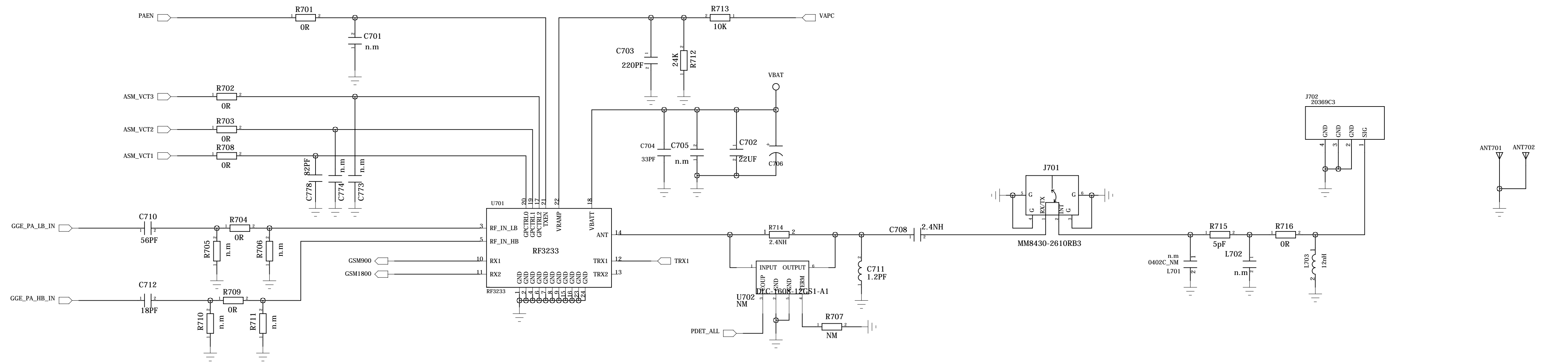

| TX mode | TX enable | Gpctrl2 | Gpctrl1 | Gpctrl0 |
|------------|-----------|---------|---------|---------|
| standby | 0 | 0 | 0 | 0 |
| RX1 | 0 | 1 | 0 | 0 |
| RX2 | 0 | 0 | 1 | 0 |
| TRX1 | 0 | 0 | 1 | 1 |
| TRX2 | 0 | 0 | 0 | 1 |
| LB GMSK | 1 | 0 | 1 | 0 |
| HB GMSK | 1 | 0 | 1 | 1 |
| LB 8PSK HG | 1 | 0 | 0 | 0 |
| LB 8PSK LG | 1 | 0 | 0 | 0 |
| HB 8PSK HG | 1 | 0 | 0 | 1 |
| HB 8PSK LG | 1 | 0 | 0 | 1 |

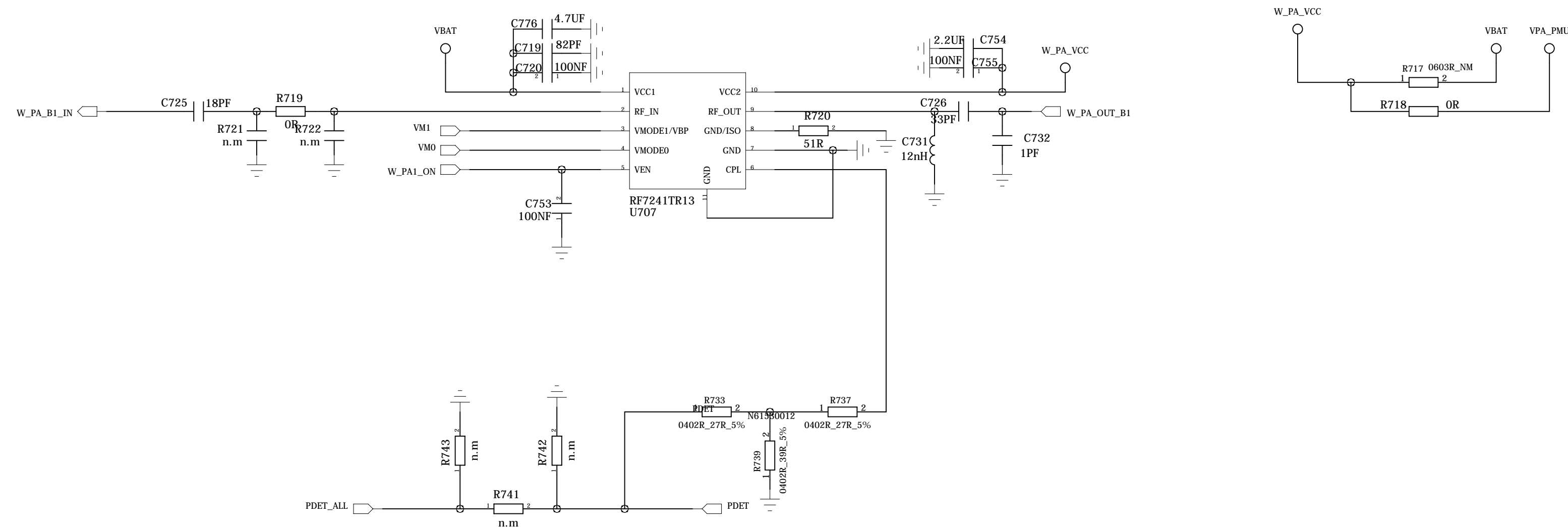

| | |
|--------------------------|-----------------------|
| COMPANY: LENOVMOBILE | |
| TITLE: Avatar_MB_H101 | |
| DRAWN: YEXL | DATED: 2011-01-28 |
| CHECKED: <Checked By> | DATED: <Checked Date> |
| QUALITY CONTROL: <QC By> | DATED: <QC Date> |
| RELEASED: <Released By> | DATED: <Release Date> |

| | | | |
|----------------|---------|------------------------------|----------------|
| CODE: <Code> | SIZE: D | DRAWING NO: <Drawing Number> | REV: V4.1 |
| SCALE: <Scale> | | | SHEET: 7 of 10 |

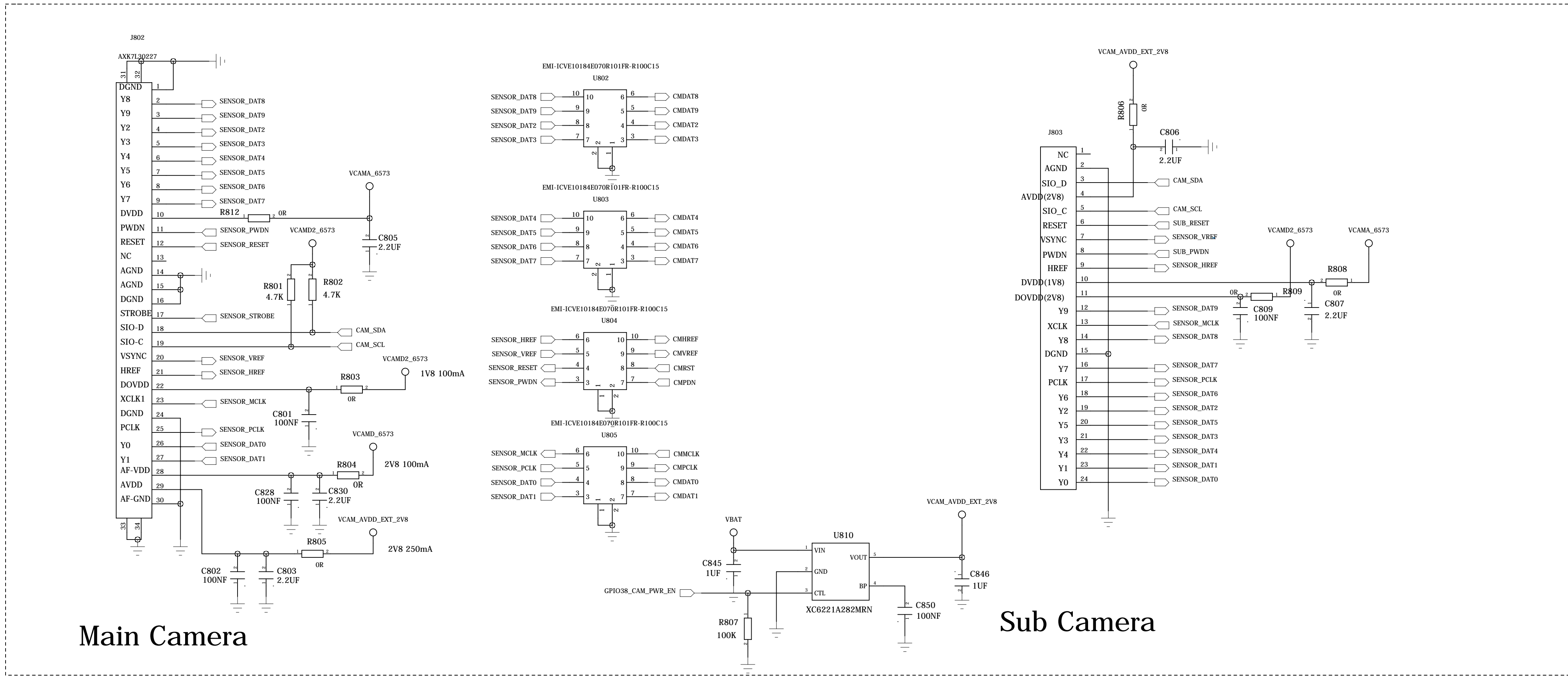
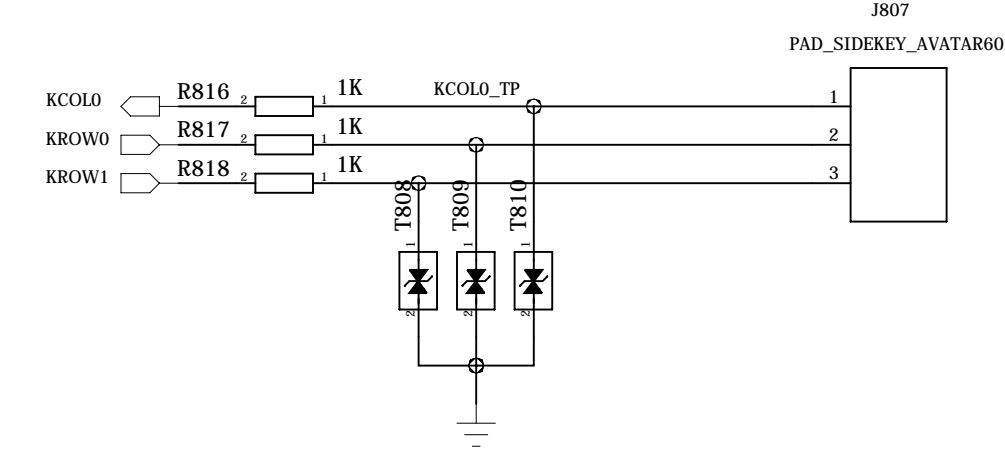
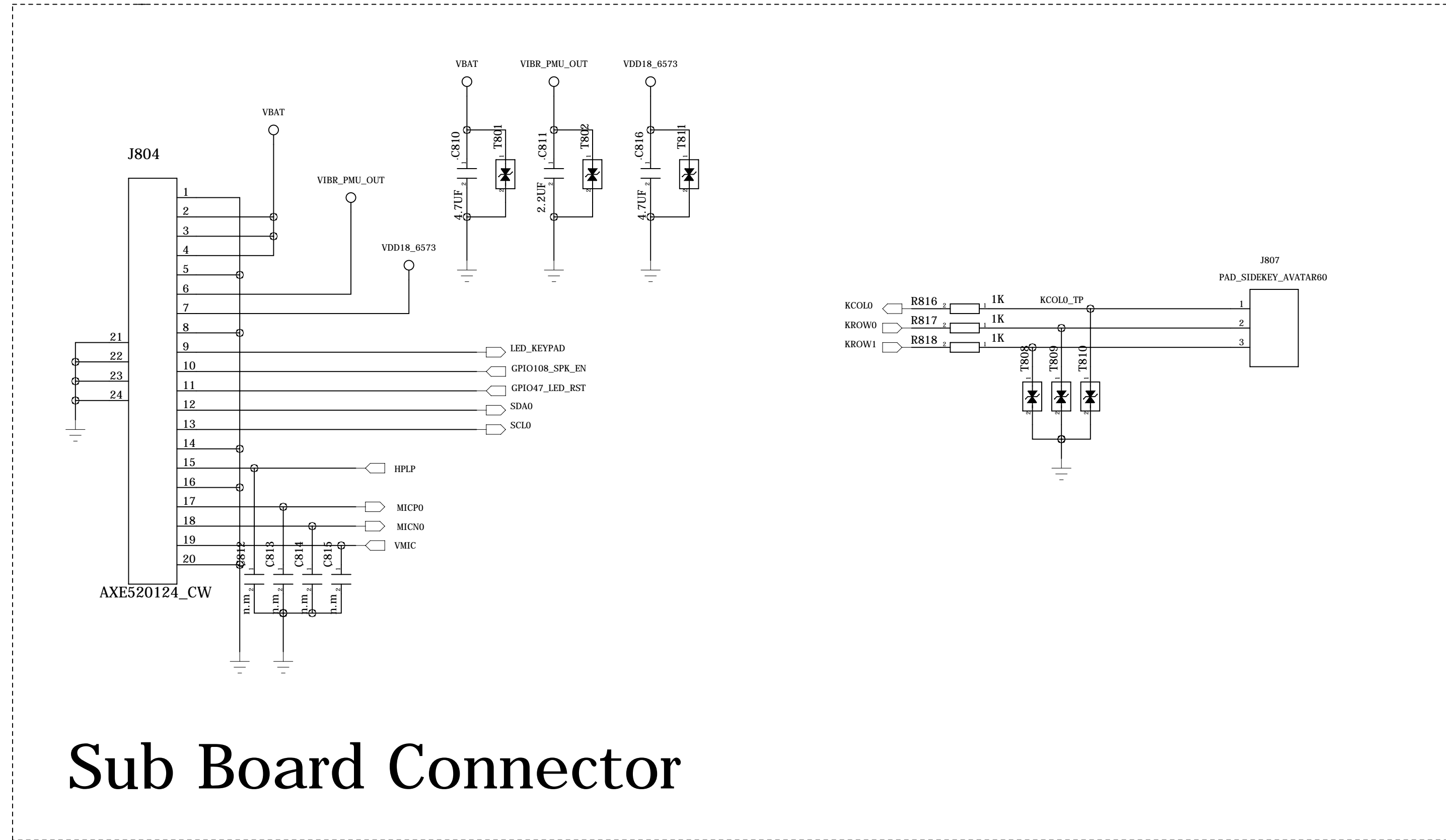
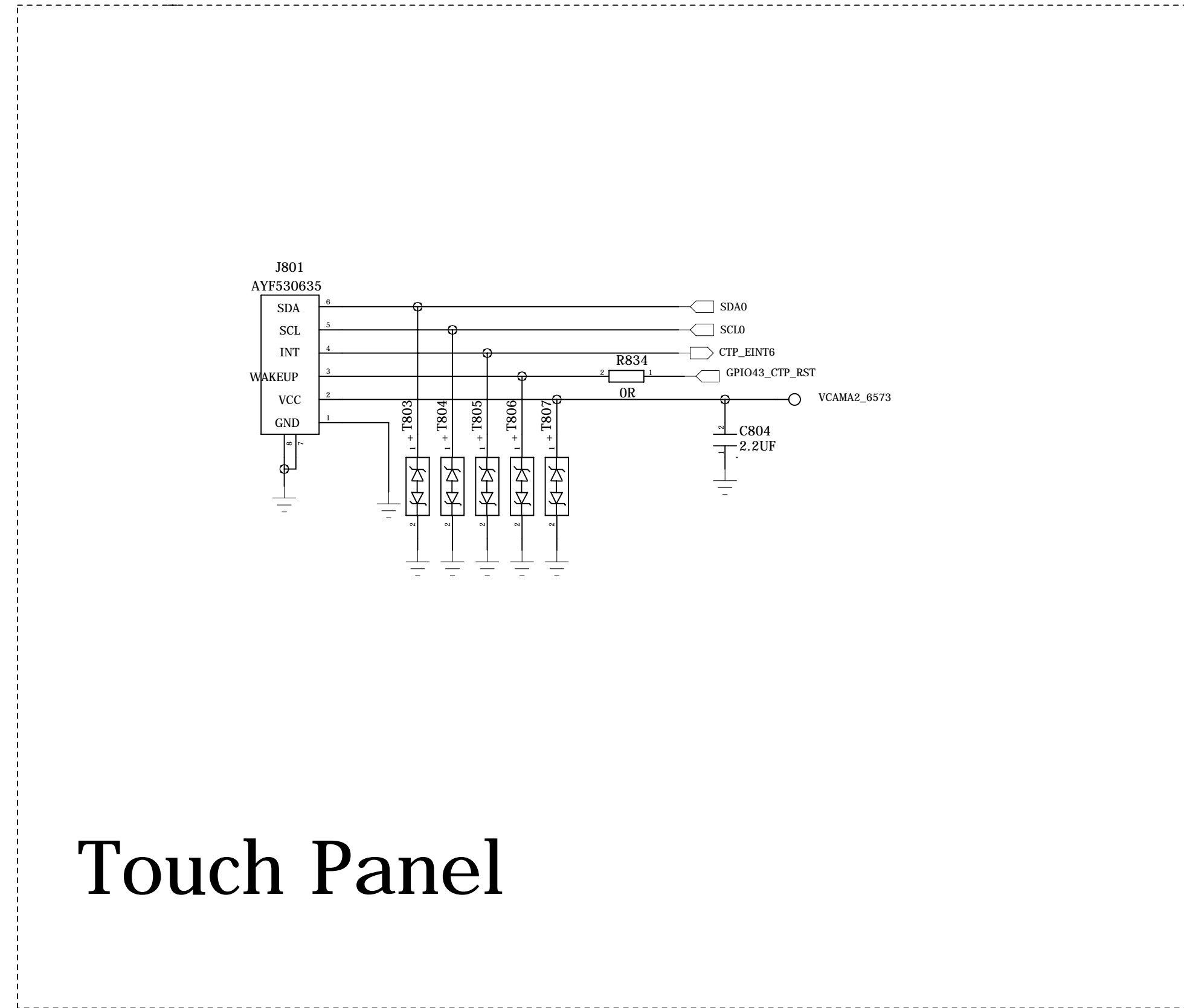

| | | | |
|--------------------------|-----------------------|---|----------------|
| COMPANY: LENOVO MOBILE | | | |
| TITLE: Avatar_MB_H101 | | | |
| DRAWN: <Drawn By> | DATED: 2011-01-28 | CODE: | SIZE: |
| CHECKED: <Checked By> | DATED: <Checked Date> | DRAWING NO: | REV: |
| QUALITY CONTROL: <QC By> | DATED: <QC Date> | <Code> D <Drawing Number> V4.1 | |
| RELEASED: <Released By> | DATED: <Release Date> | SCALE: <Scale> | SHEET: 8 of 10 |

| REVISION RECORD | | | |
|-----------------|---------|-----------|-------|
| LTR | ECO NO. | APPROVED: | DATE: |
| | | | |
| | | | |
| | | | |

SD CARD

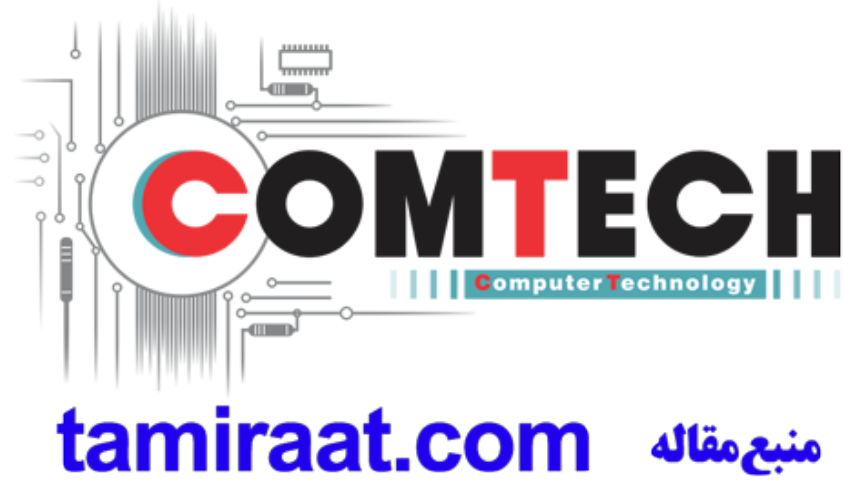
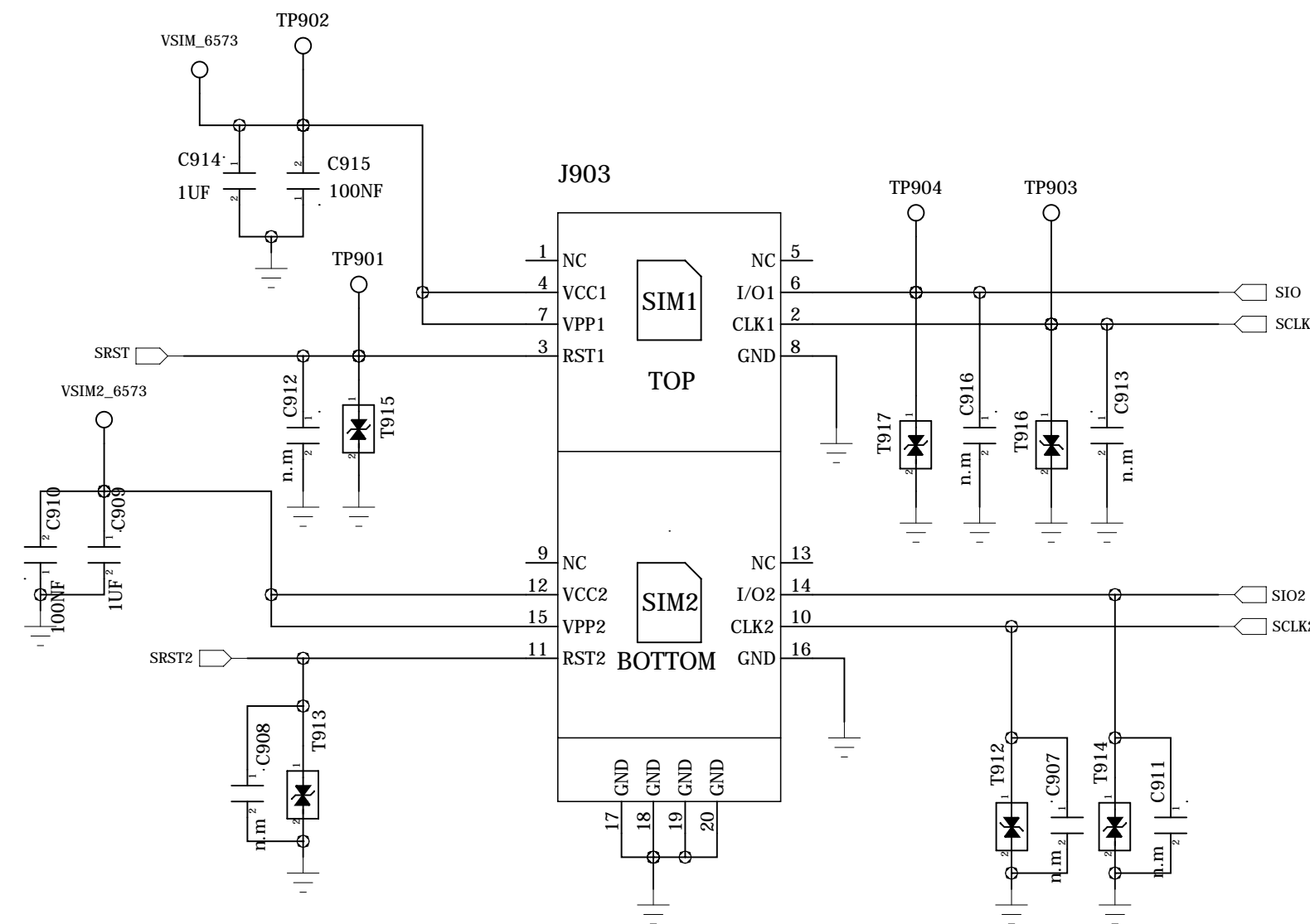
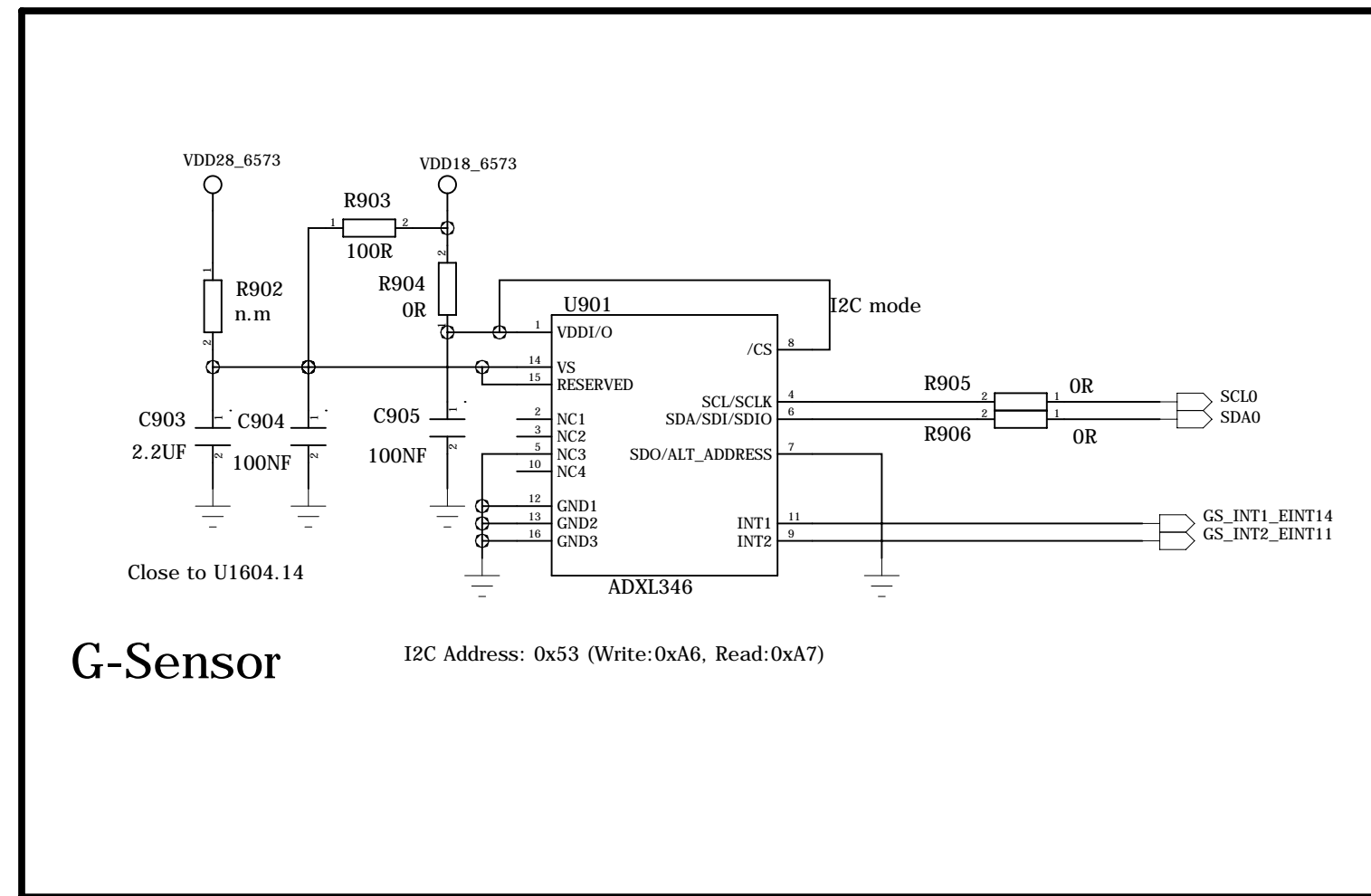
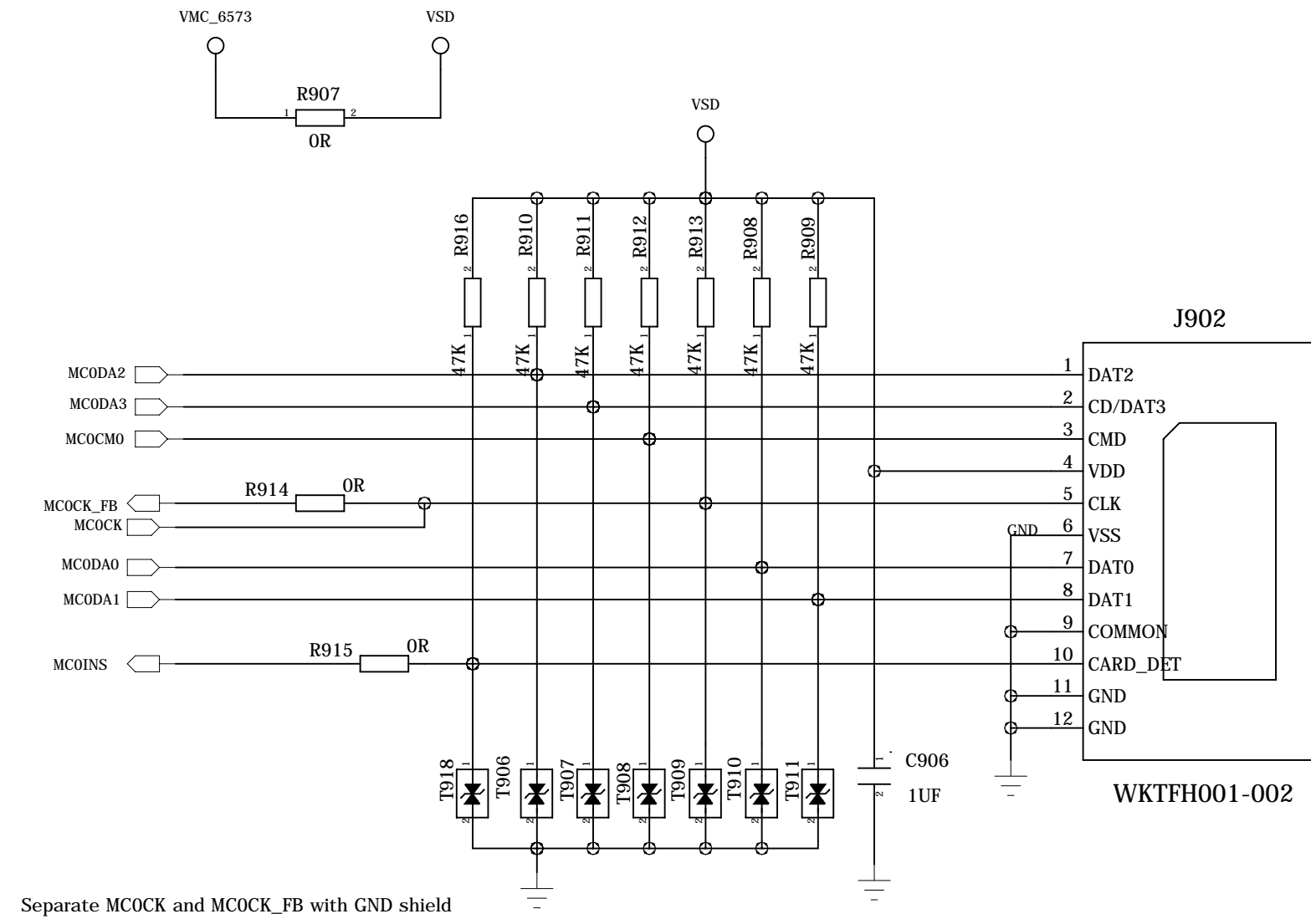

| | | | |
|-----------------------------|--------------------------|------------------------|----------------|
| COMPANY: LENOVO MOBILE | | | |
| TITLE: Avatar_MB_H101 | | | |
| DRAWN: <Drawn By> | DATED: 2011-01-28 | CODE: | SIZE: |
| CHECKED: <Checked By> | DATED: <Checked Date> | DRAWING NO: | REV: |
| QUALITY CONTROL: <QC By> | DATED: <QC Date> | D<Drawing Number> V4.1 | |
| RELEASED: <Released By> | DATED: <Release Date> | SCALE: <Scale> | SHEET: 9 of 10 |

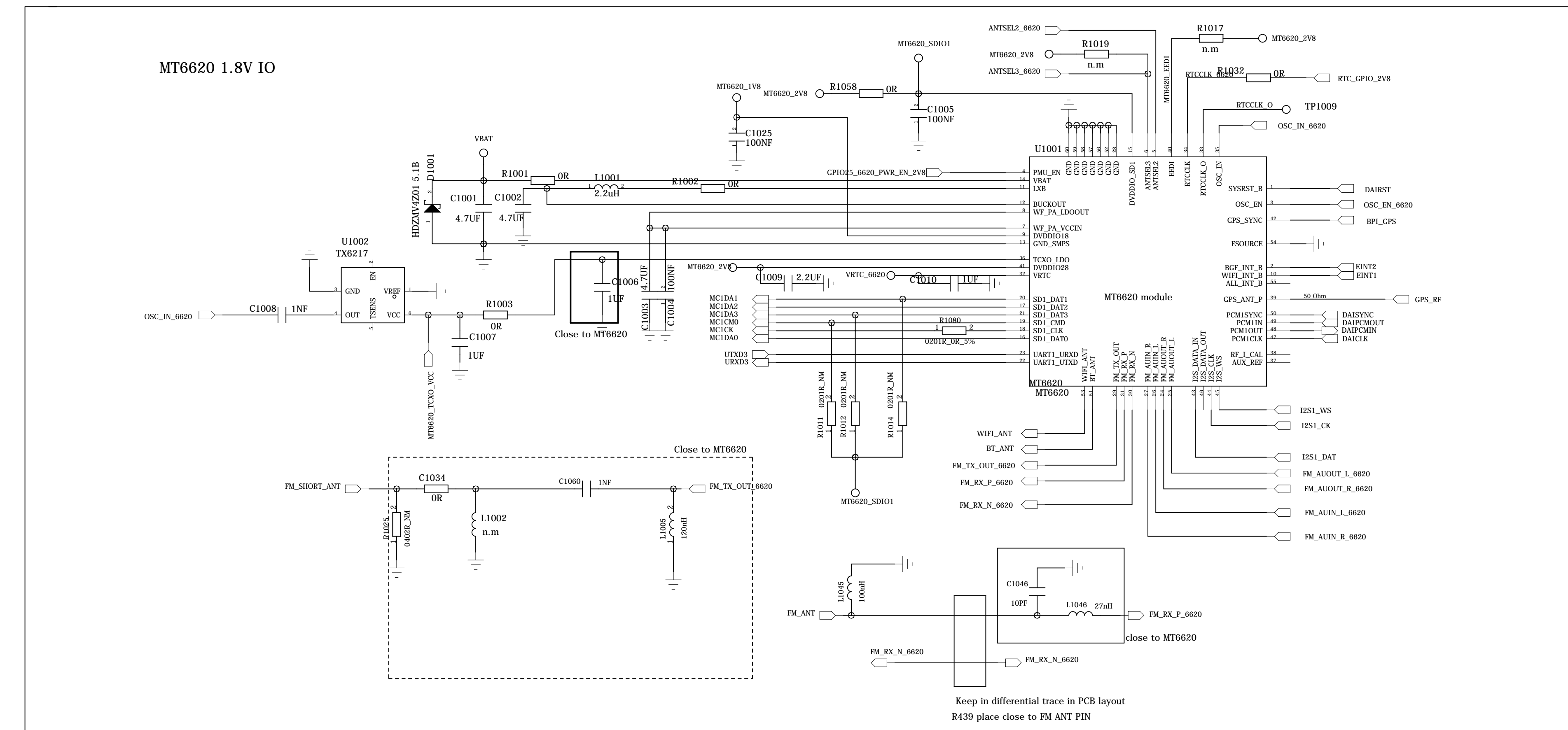
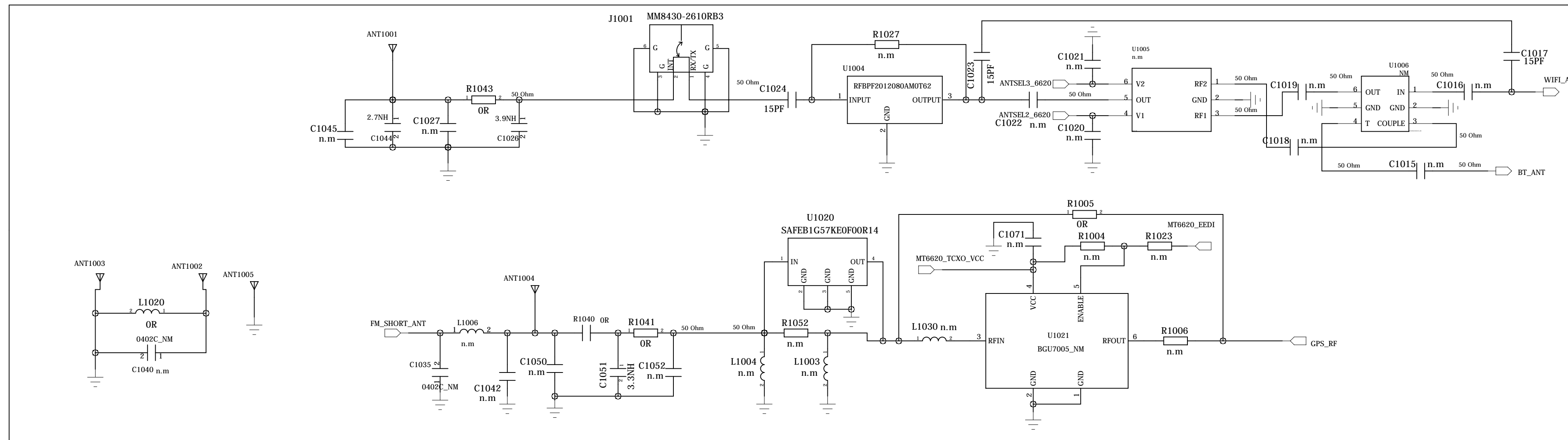

| | | XTES1 | EEDI | ANTSEL_3 | |
|--------------------------|---------------------|-------|------|----------|---------|
| clock setting | 2.8V TCXO or OSC | 0 | 0 | 0 | Default |
| | 1.8V TCXO or OSC | 0 | 1 | 0 | |
| | XTAL | 0 | 0 | 1 | |
| | external clock mode | 0 | 1 | 1 | |
| WIFI host interface | WIFI:SDIO1 | 0 | 0 | 0 | Default |
| | WIFI:SDIO2 | 0 | 0 | 1 | |
| | WIFI:SPI | 0 | 1 | 0 | |
| | WIFI:reserved | 0 | 1 | 1 | |
| BT/common host interface | UART1 | 0 | 0 | | Default |
| | SDIO2 | 0 | 1 | | |

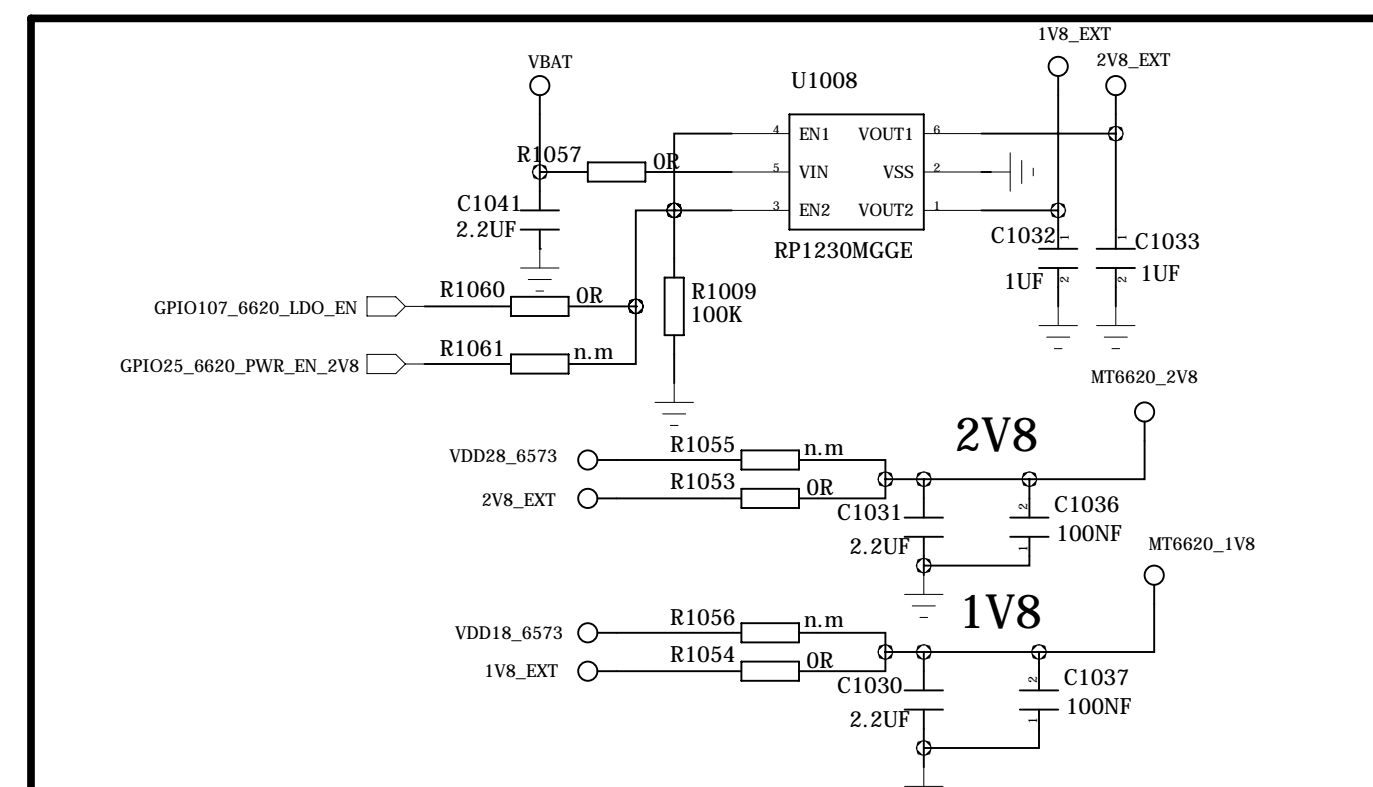
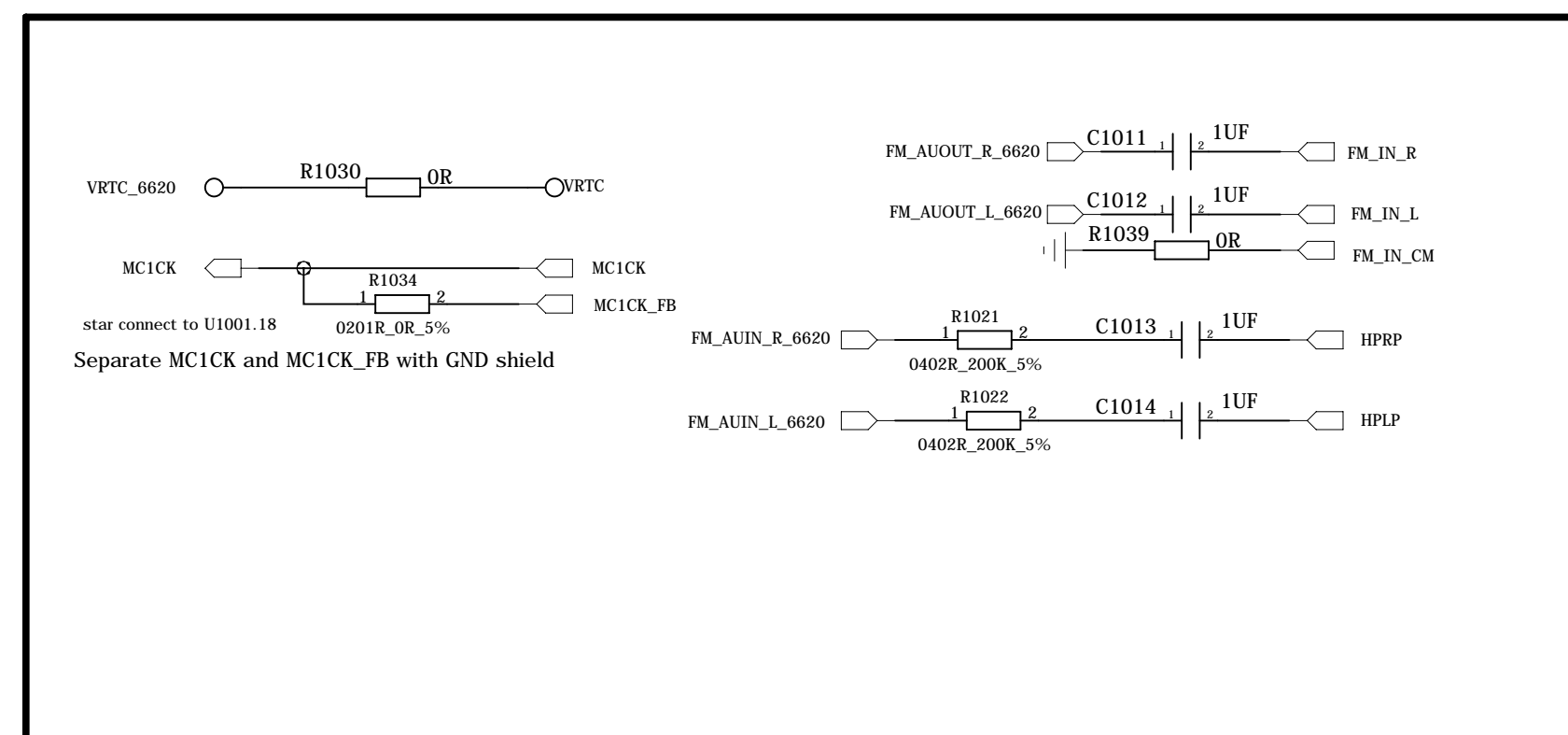

| | | | | | |
|--------------------------|-----------------------|-----------------------|-----------|------------------------------|-----------|
| DRAWN: <Drawn By> | | DATED: 2011-01-28 | | COMPANY: LENOVO MOBILE | |
| CHECKED: <Checked By> | | DATED: <Checked Date> | | TITLE: Avatar_MB_H101 | |
| QUALITY CONTROL: <QC By> | DATED: <QC Date> | CODE: <Code> | SIZE: D | DRAWING NO: <Drawing Number> | REV: V4.1 |
| RELEASED: <Released By> | DATED: <Release Date> | SCALE: <Scale> | SHEET: 10 | | 10 |