

\* 1 : Shielded

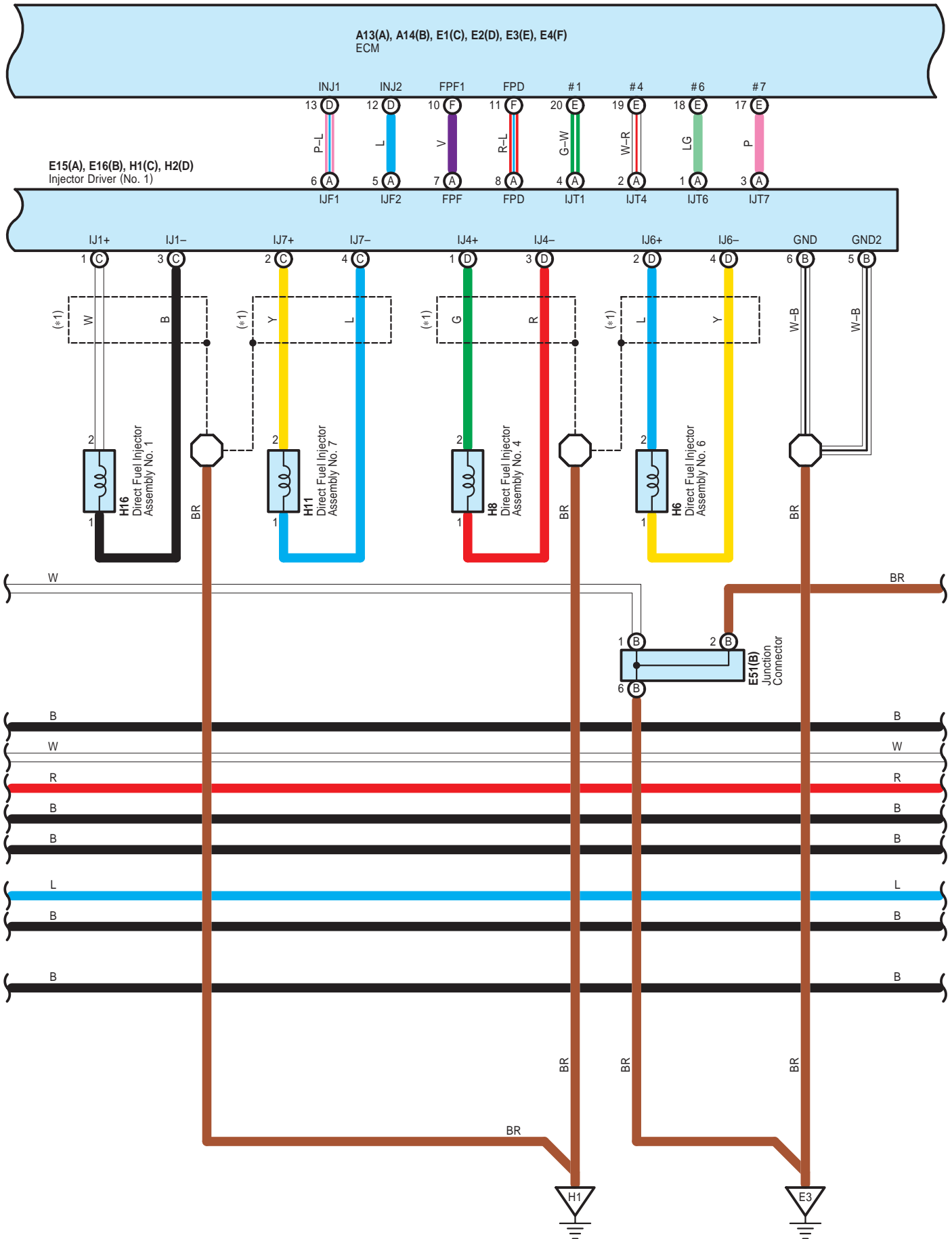

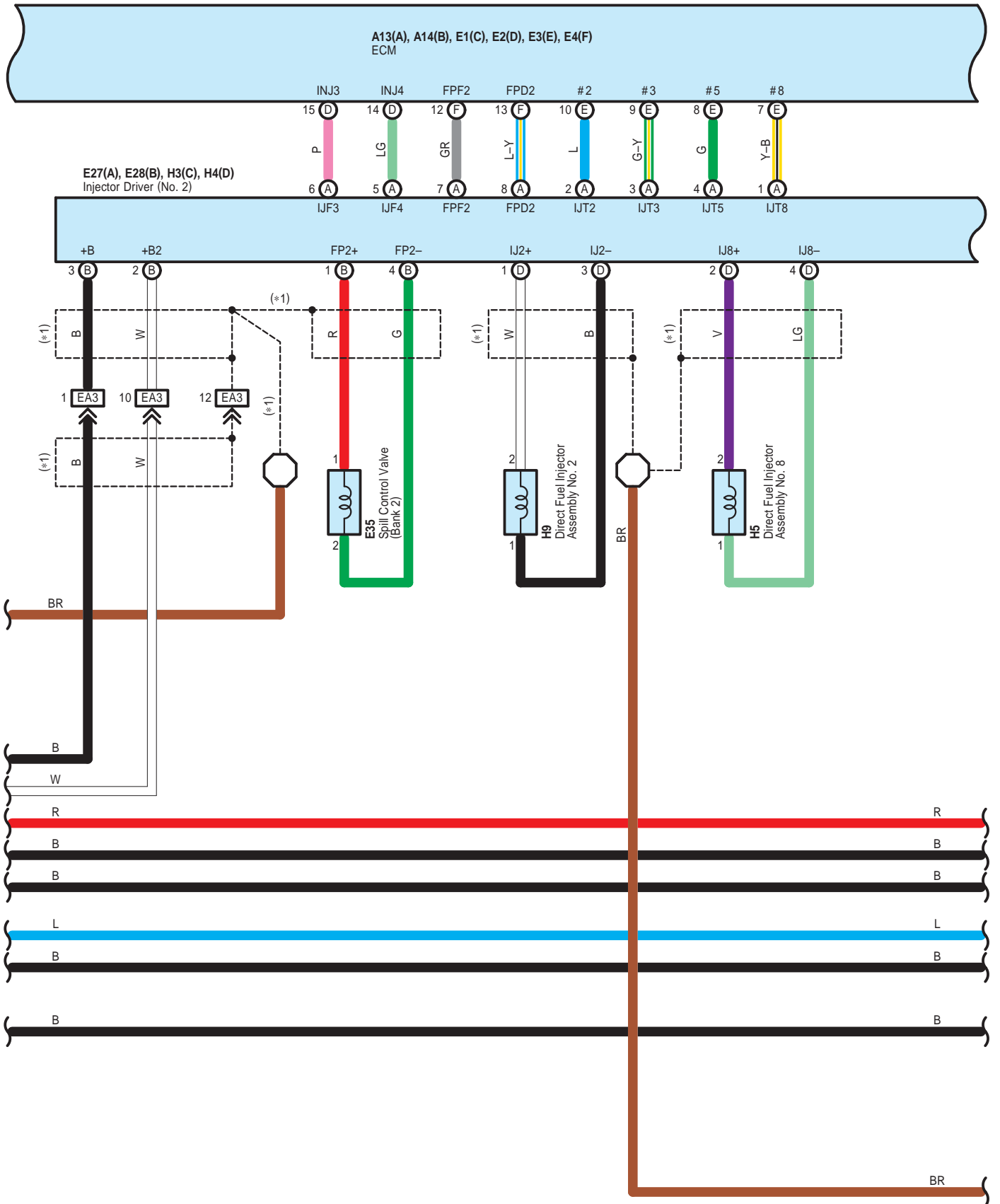

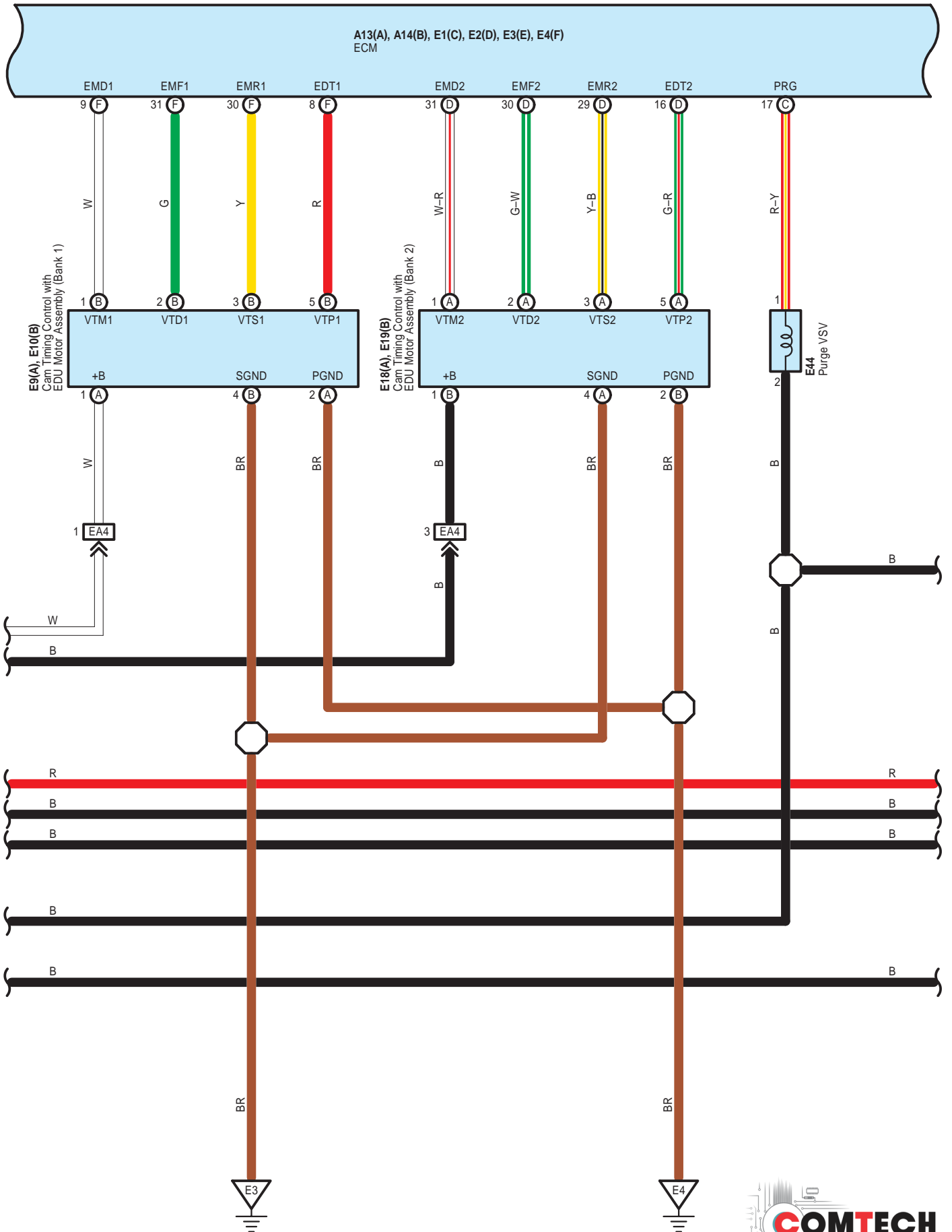



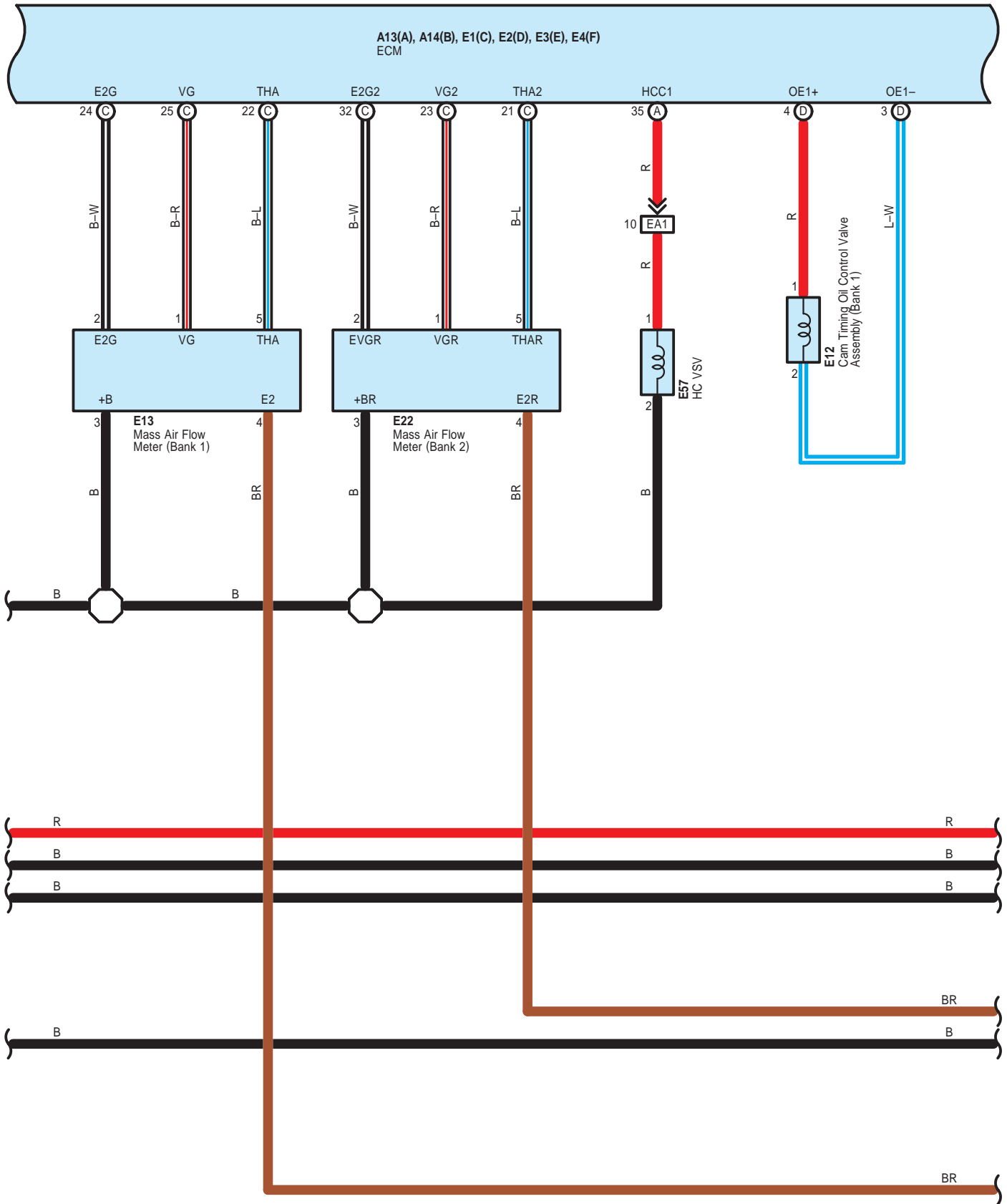



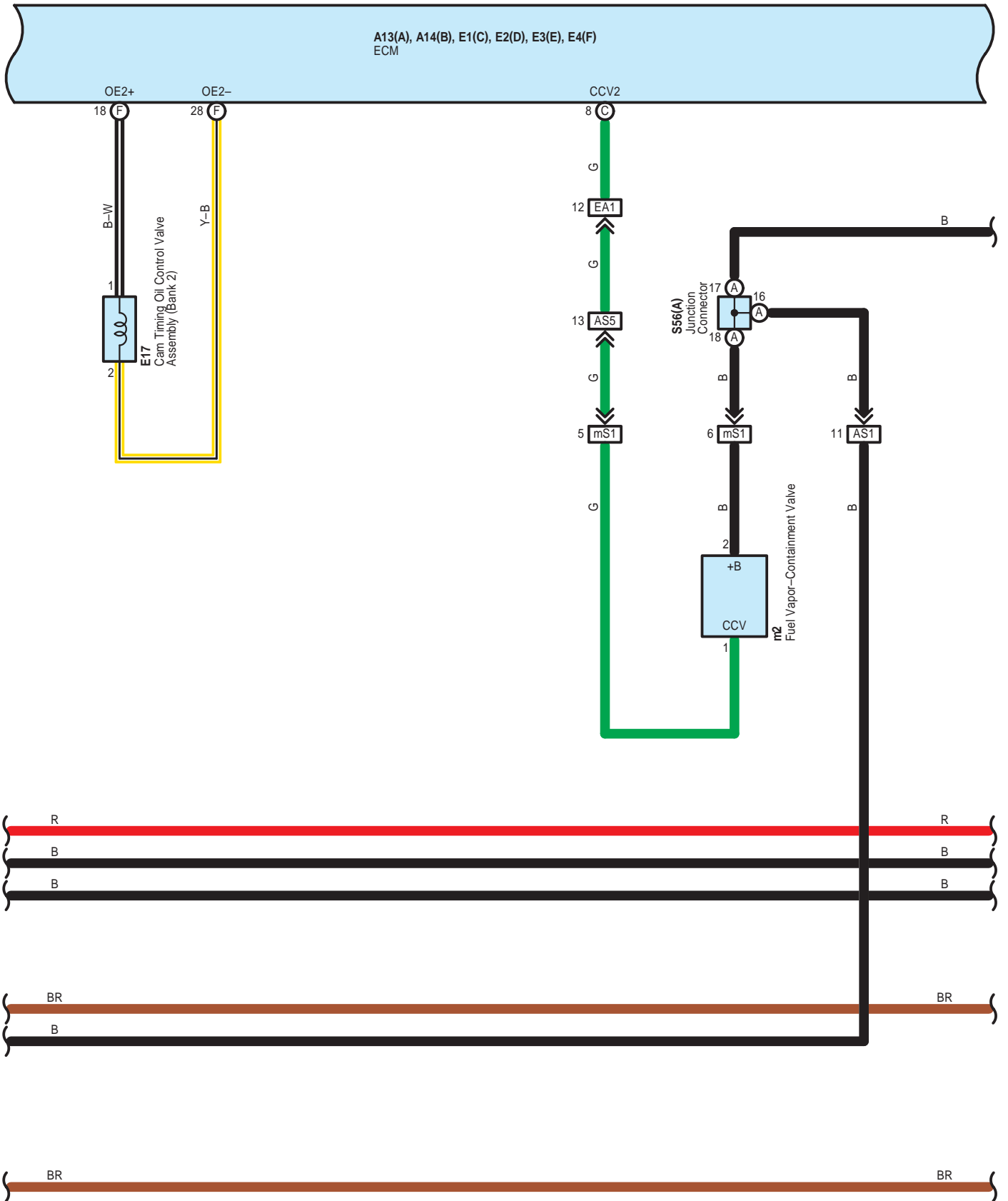

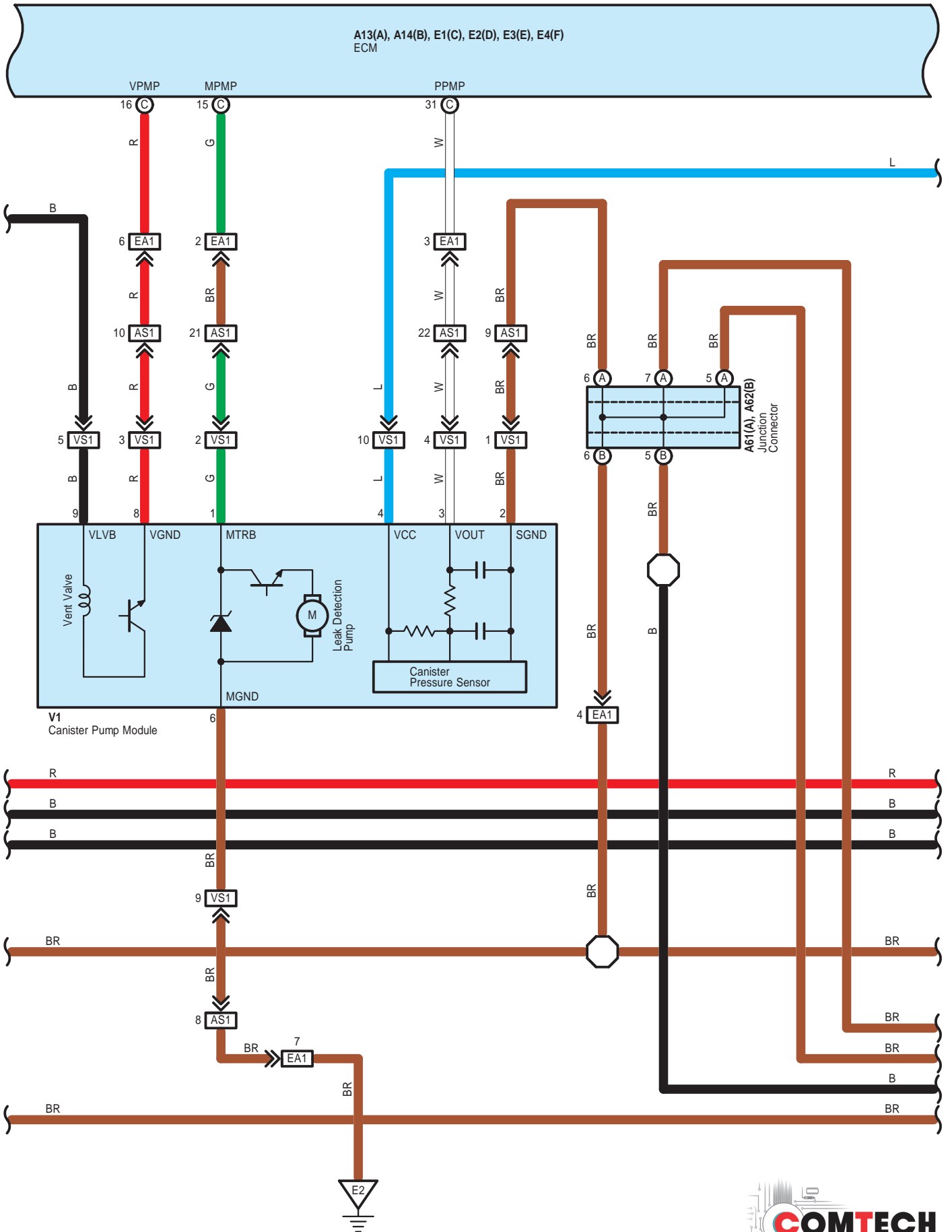

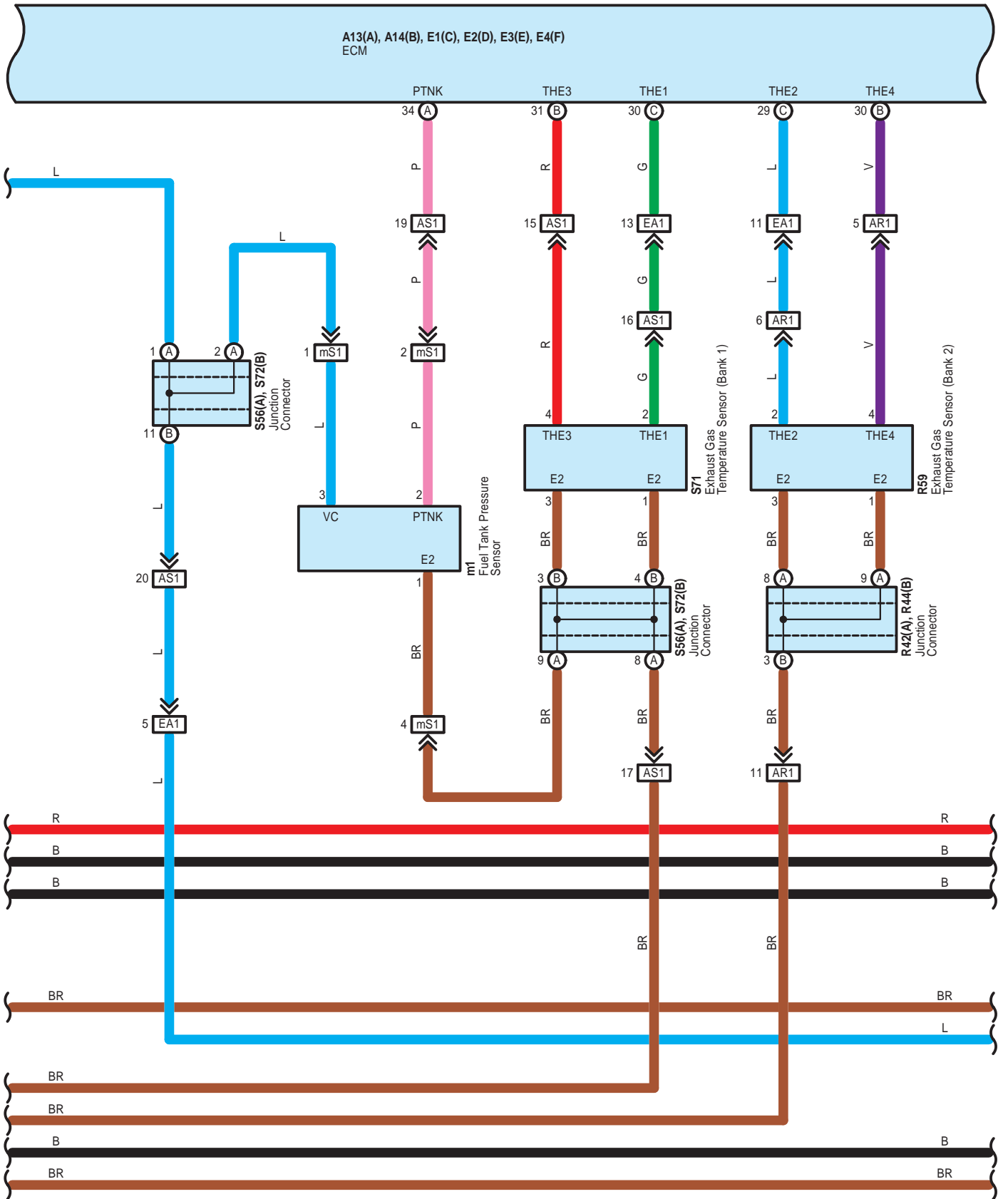

\* 1 : Shielded

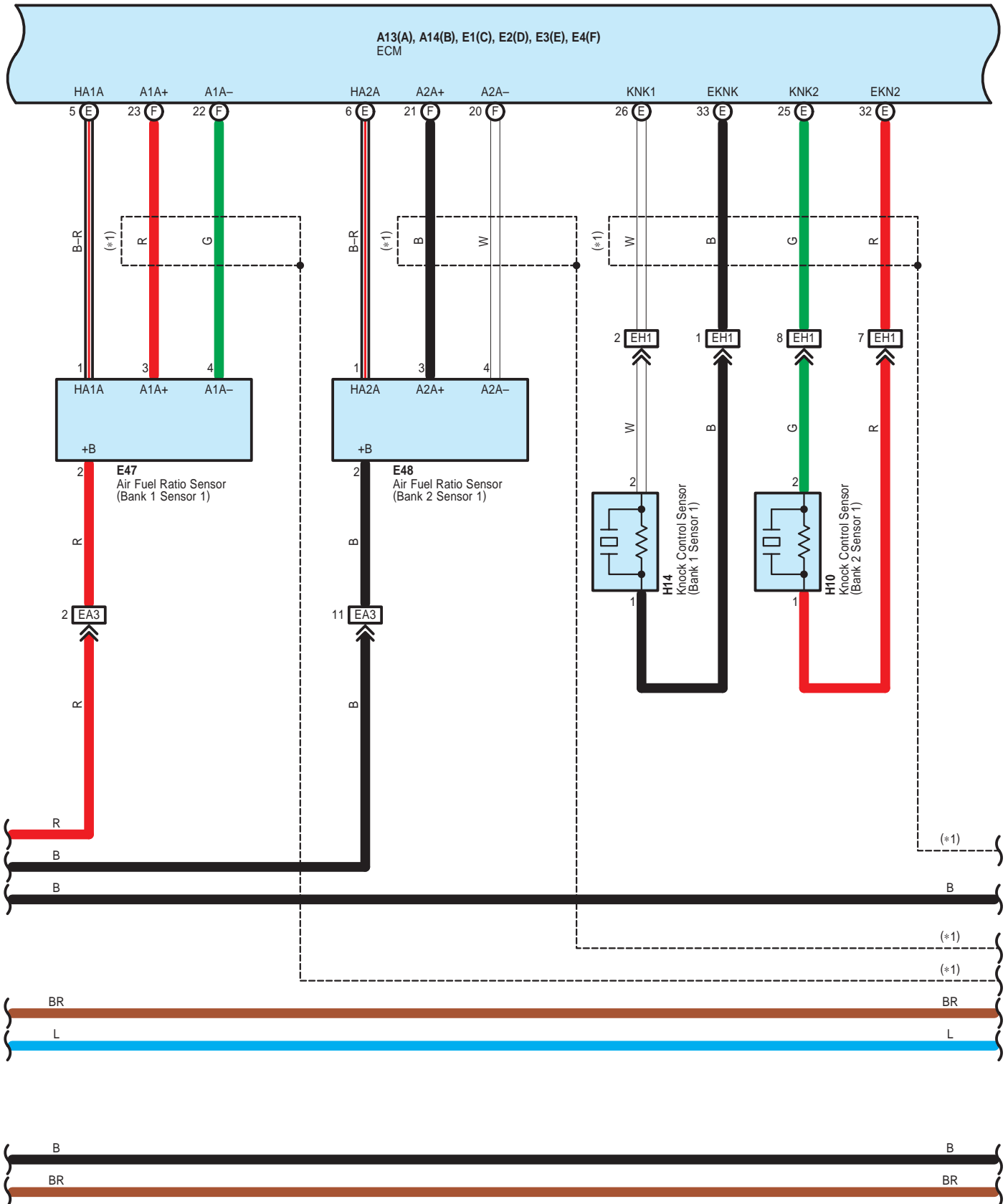

\* 1 : Shielded

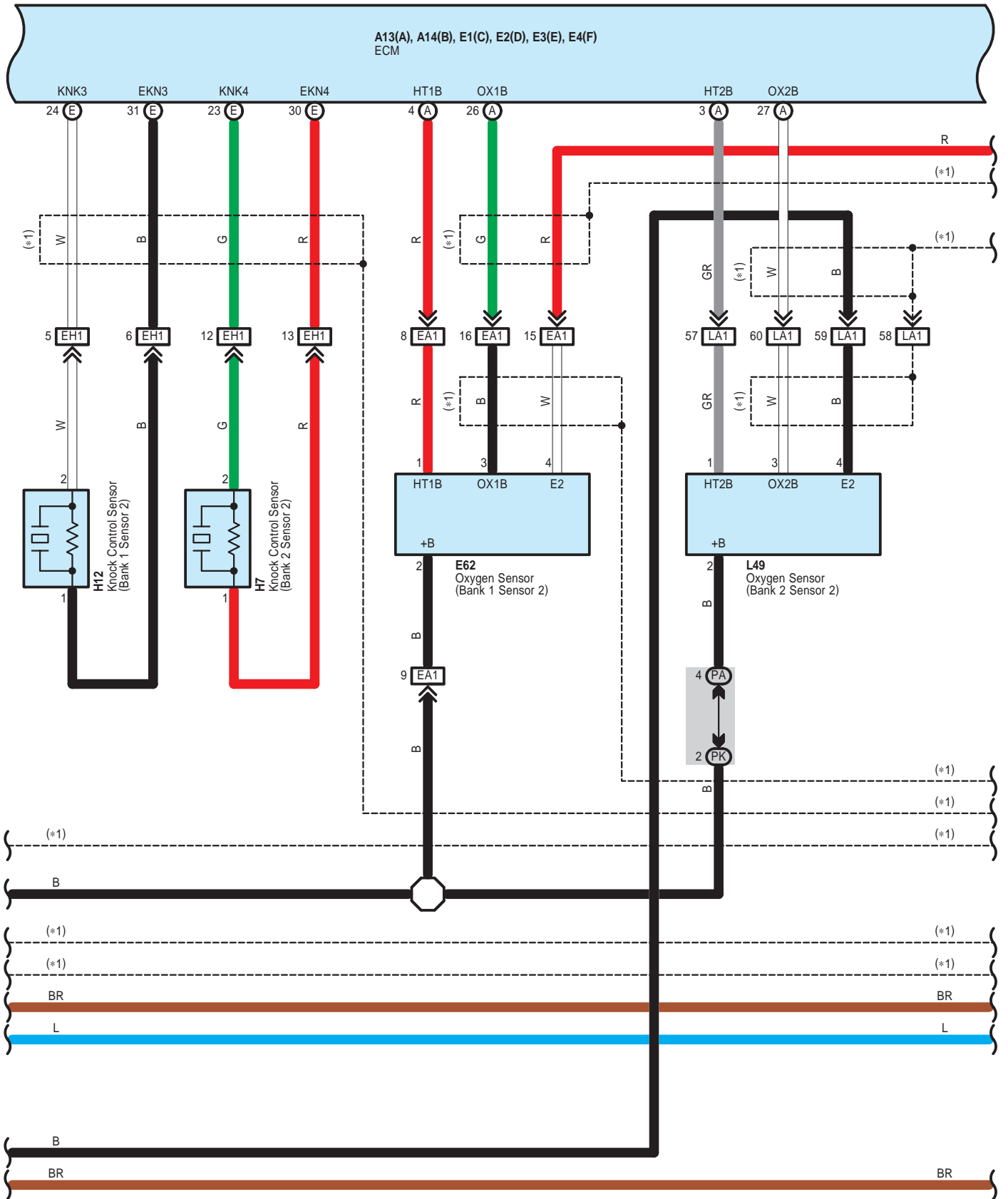

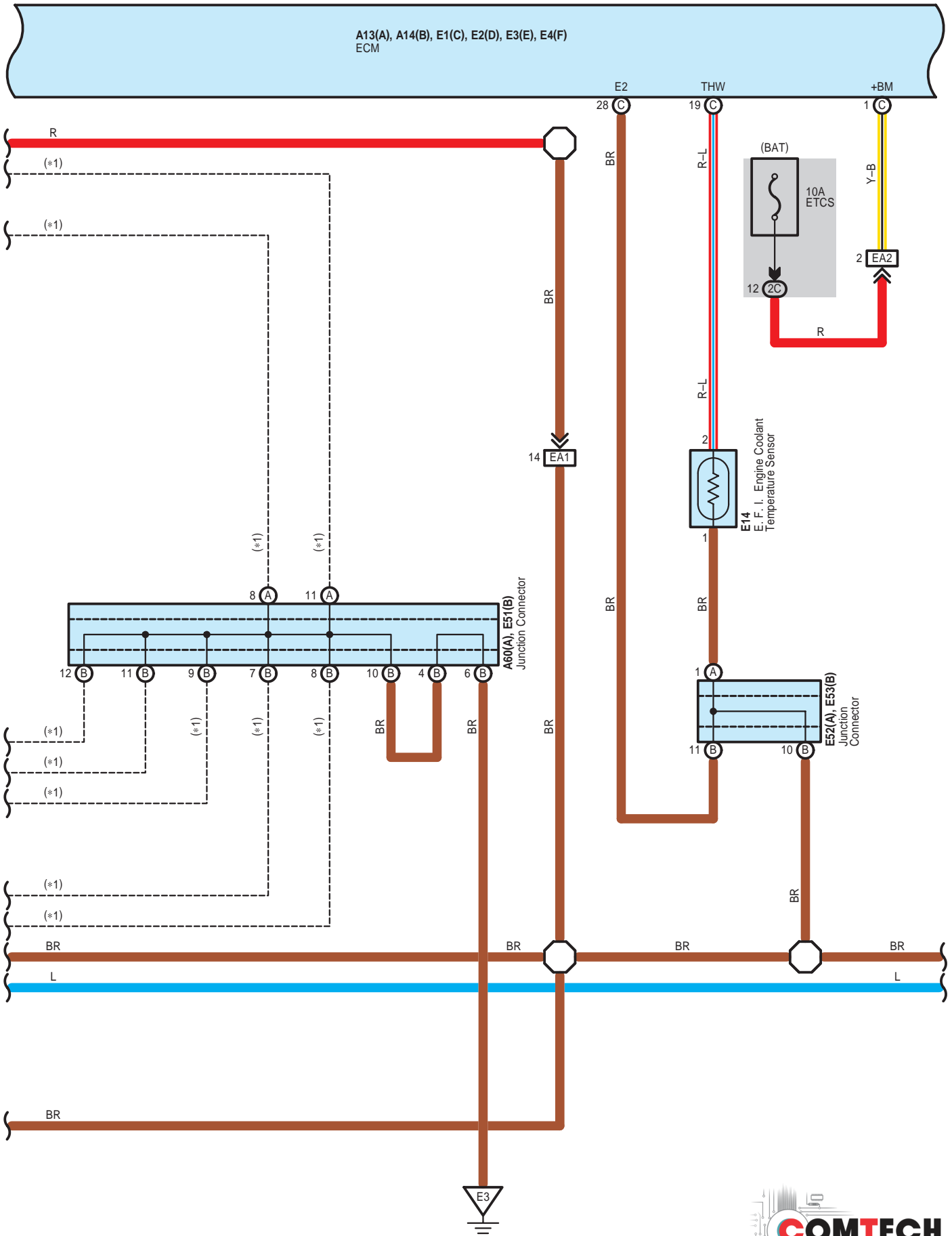

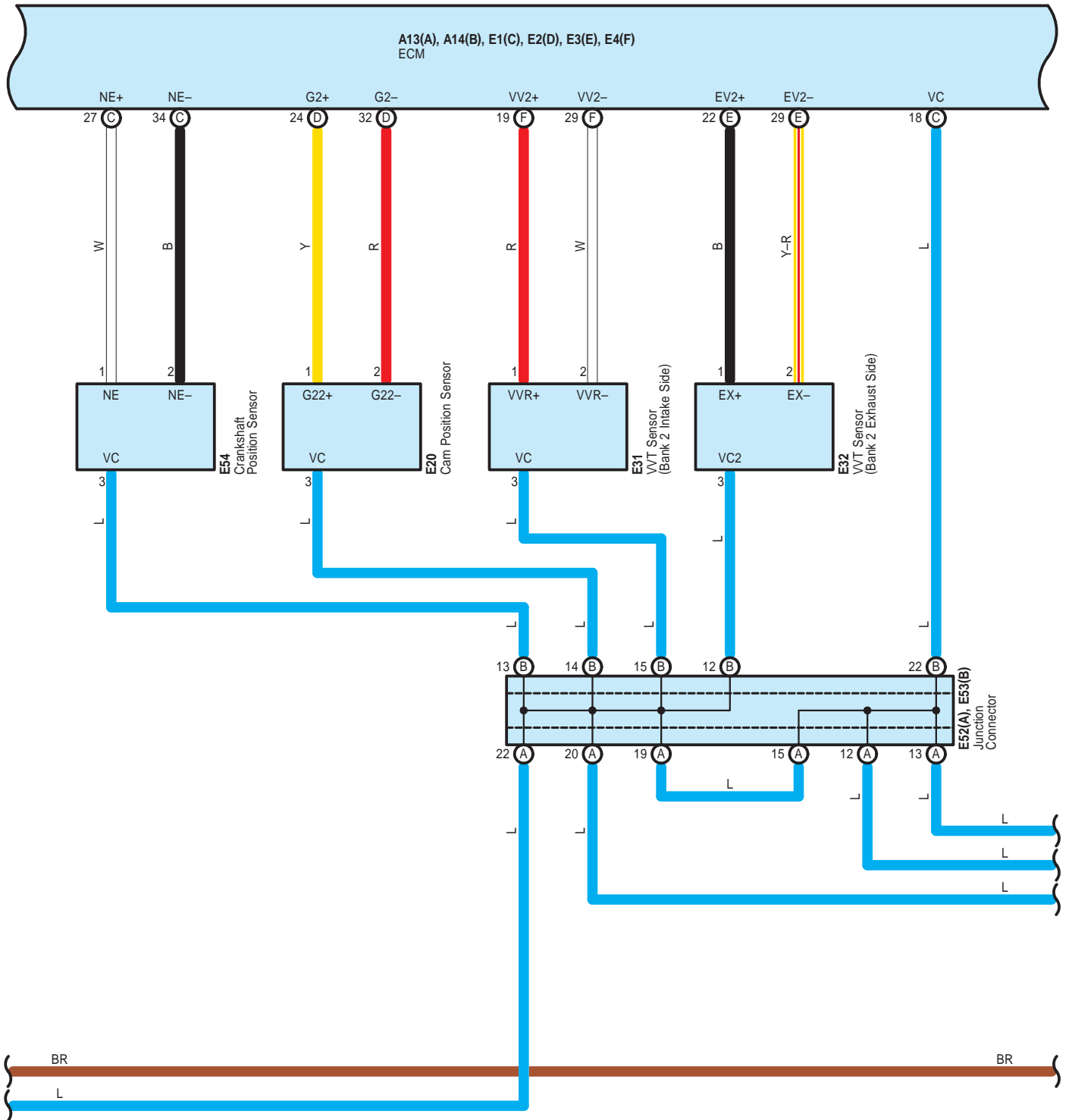

Engine Control

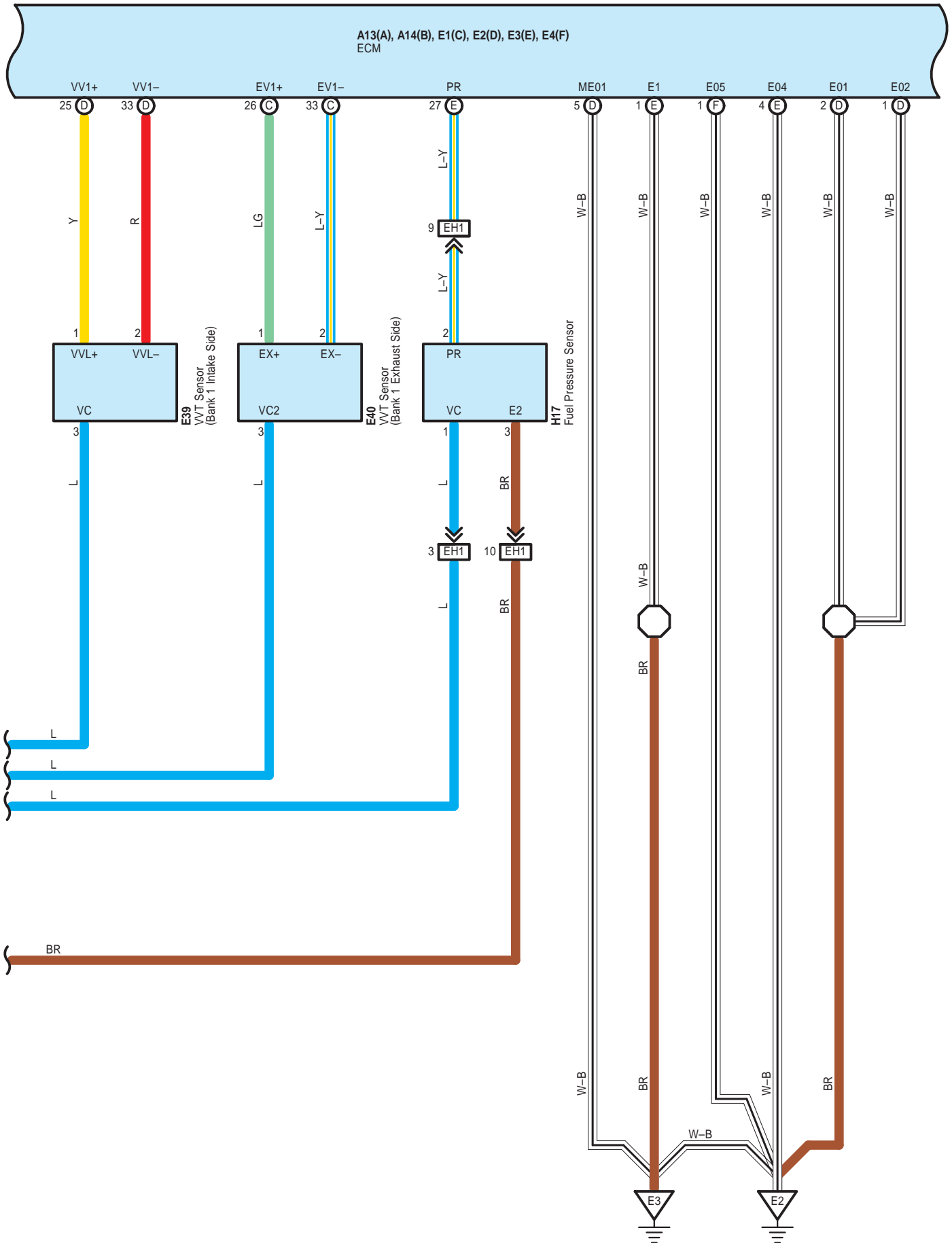



\* 1 : Shielded

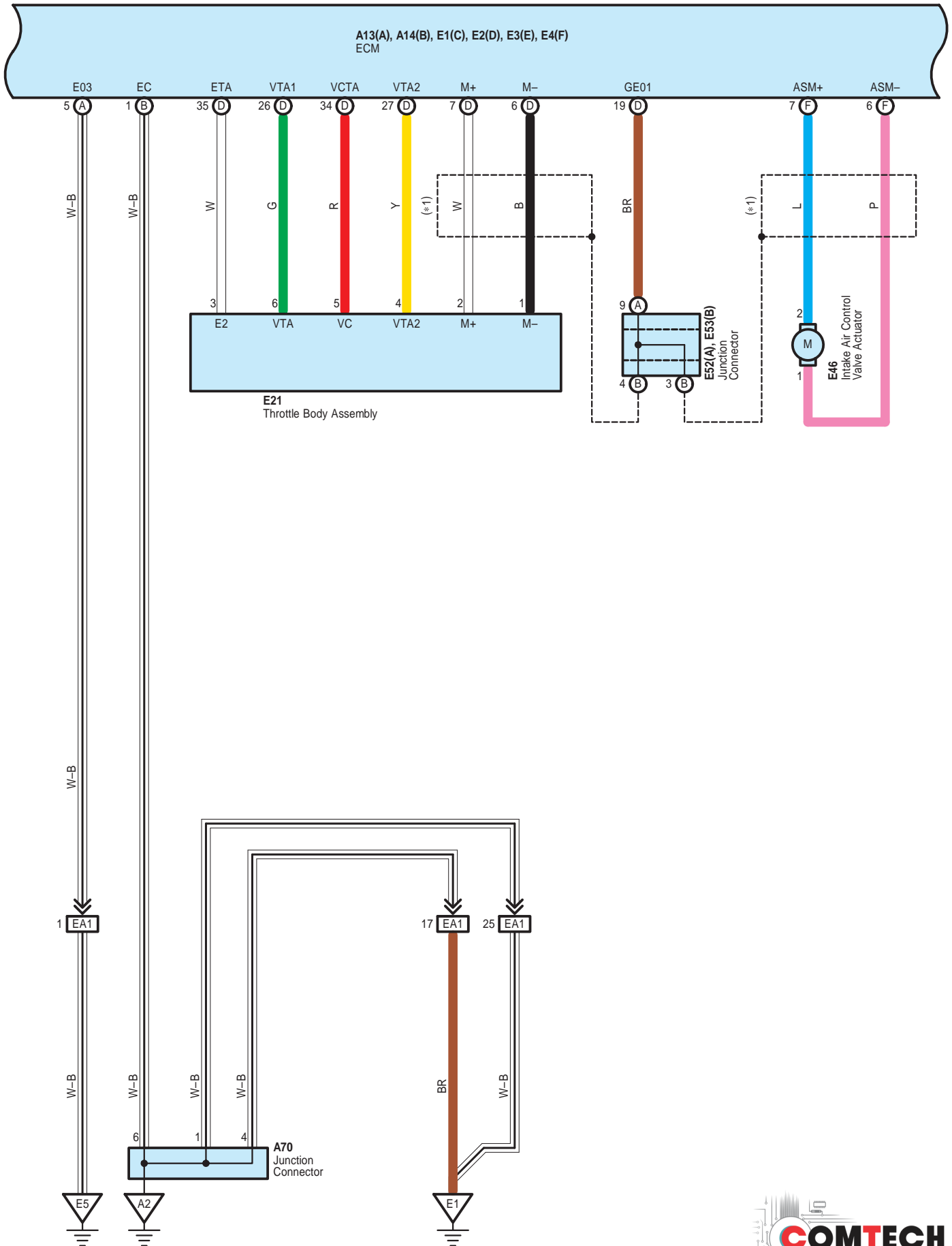

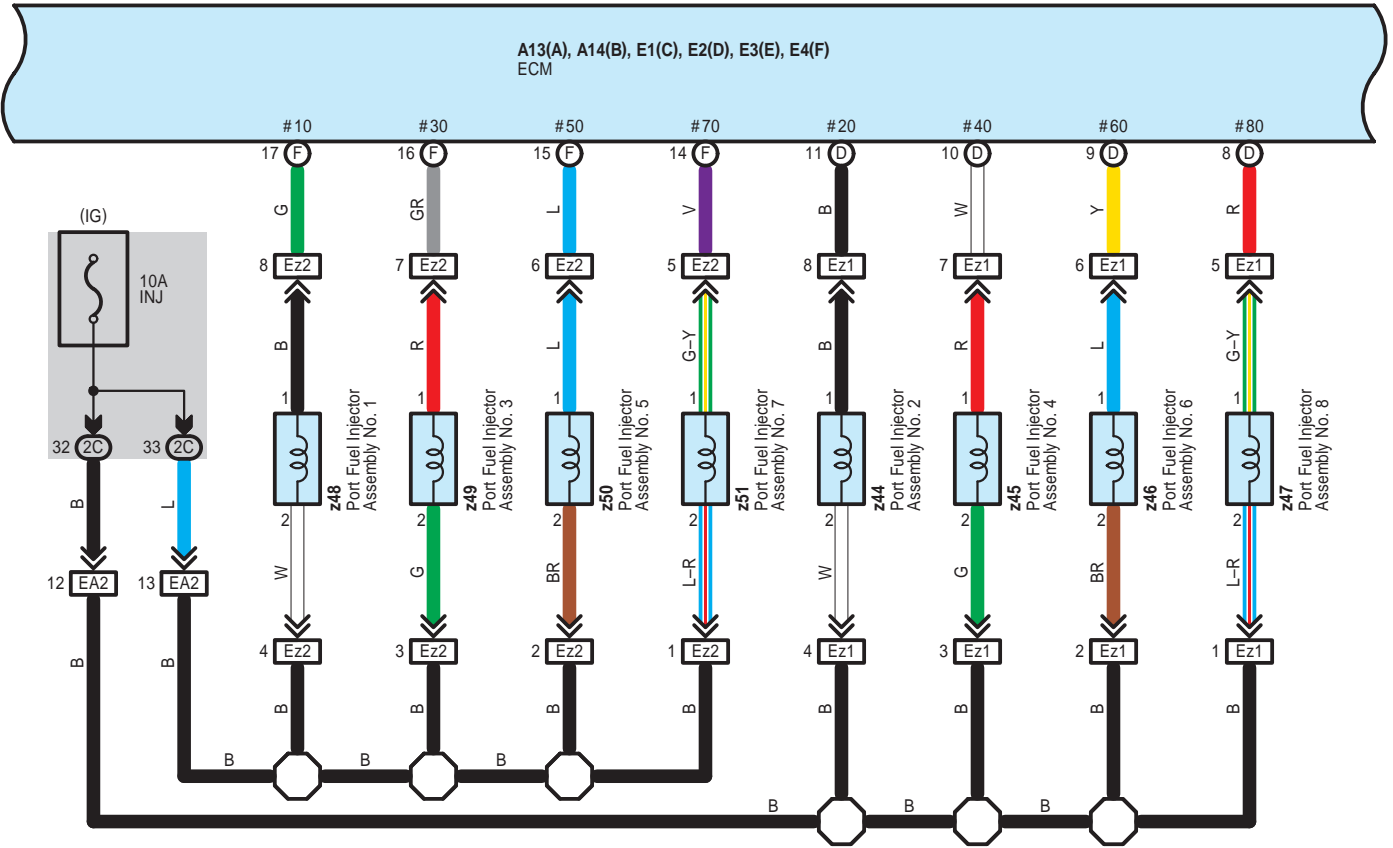

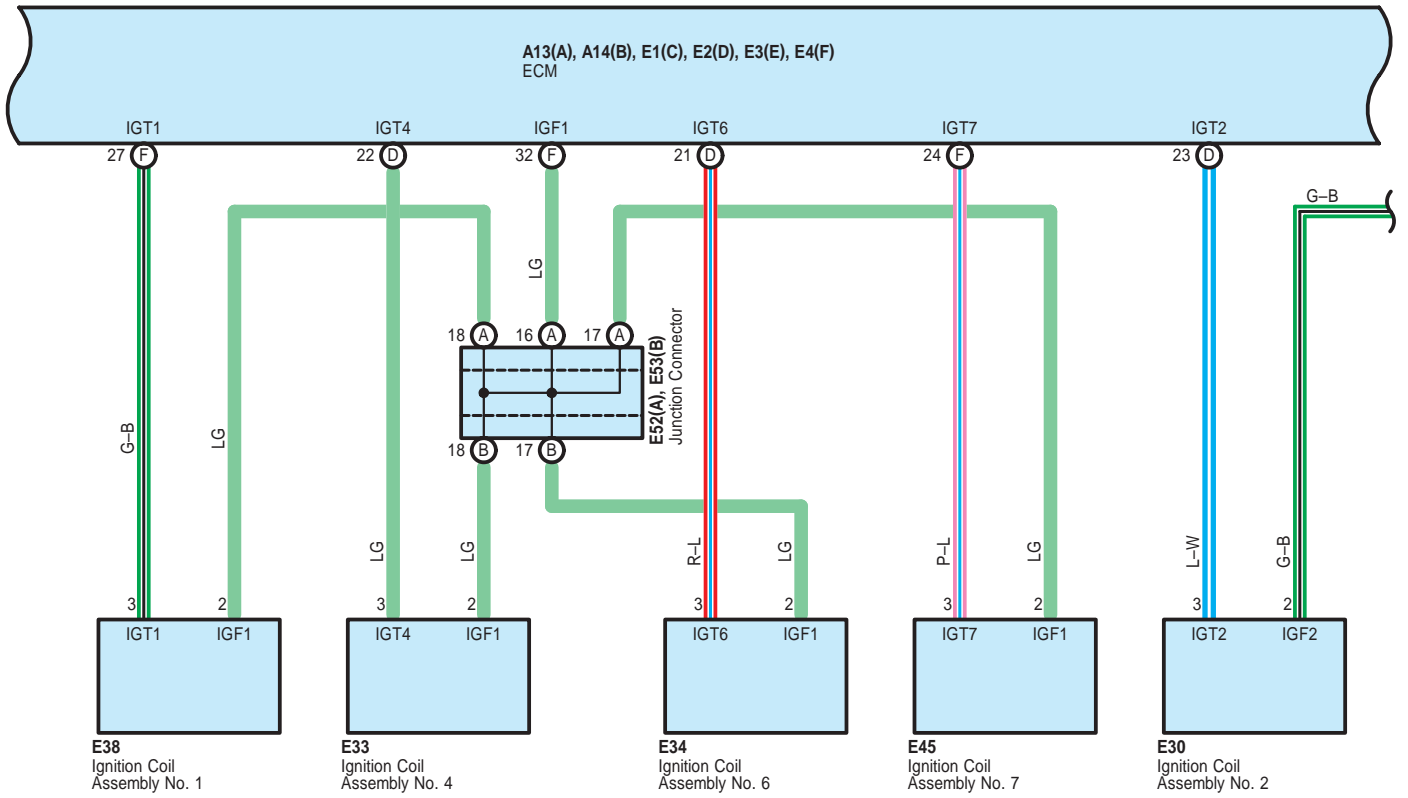



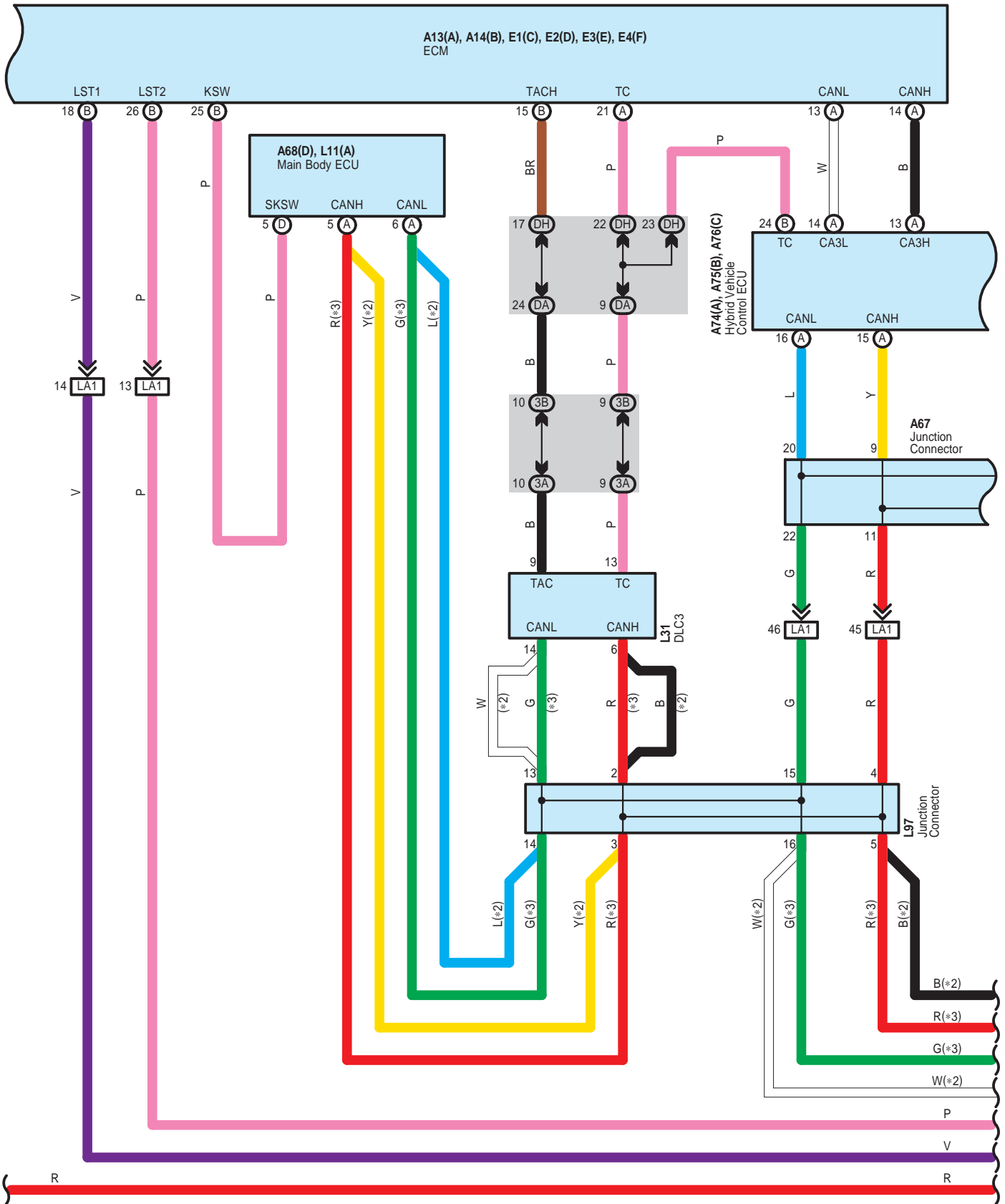

Note :  
Please refer to the Multiplex Communication System (CAN) section  
for information regarding the shielded communication lines.

- \* 1 : Shielded
- \* 2 : Before May 2010 Production
- \* 3 : From May 2010 Production

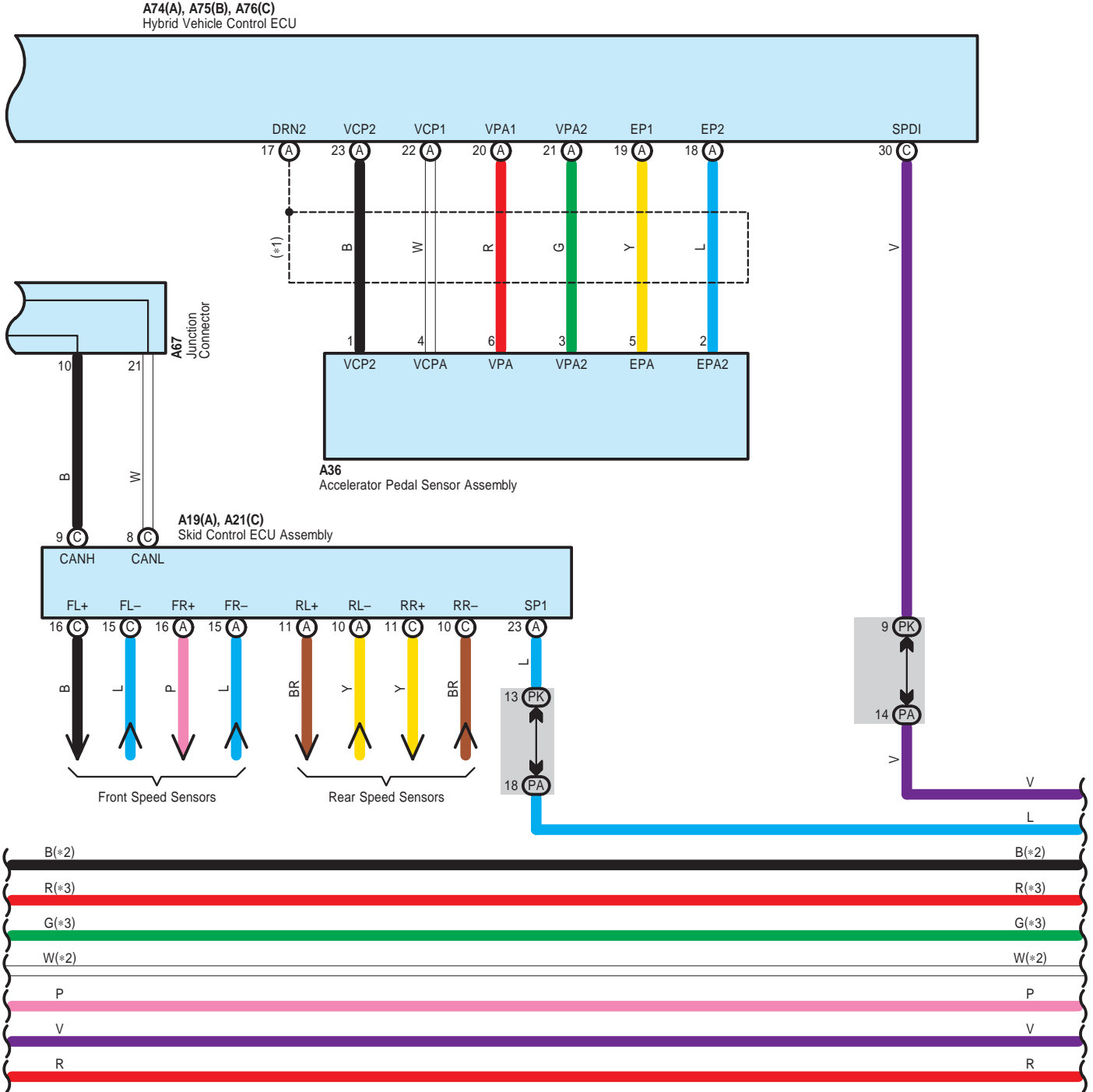

Note :  
Please refer to the Multiplex Communication System (CAN) section  
for information regarding the shielded communication lines.

\* 2 : Before May 2010 Production  
\* 3 : From May 2010 Production

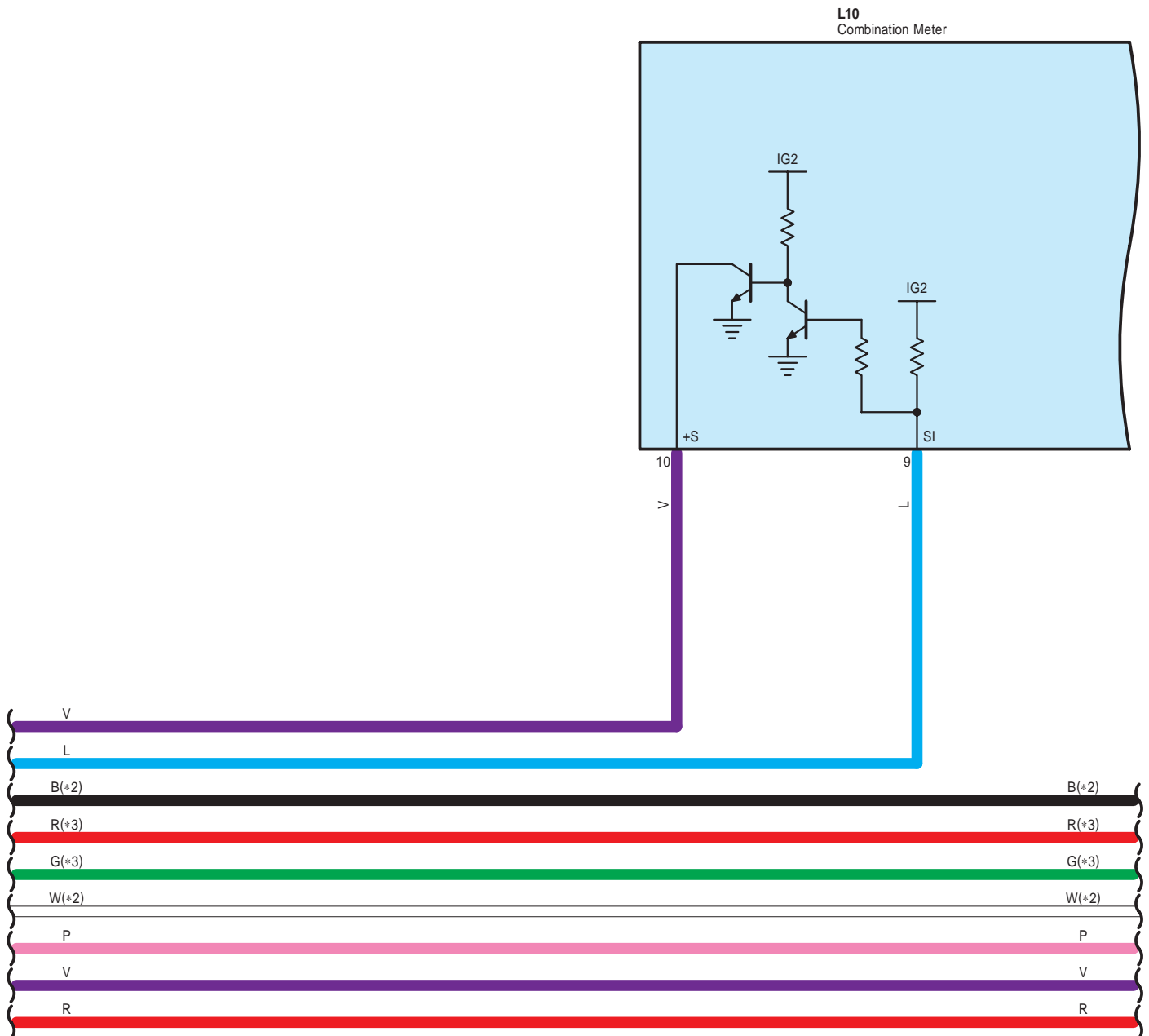

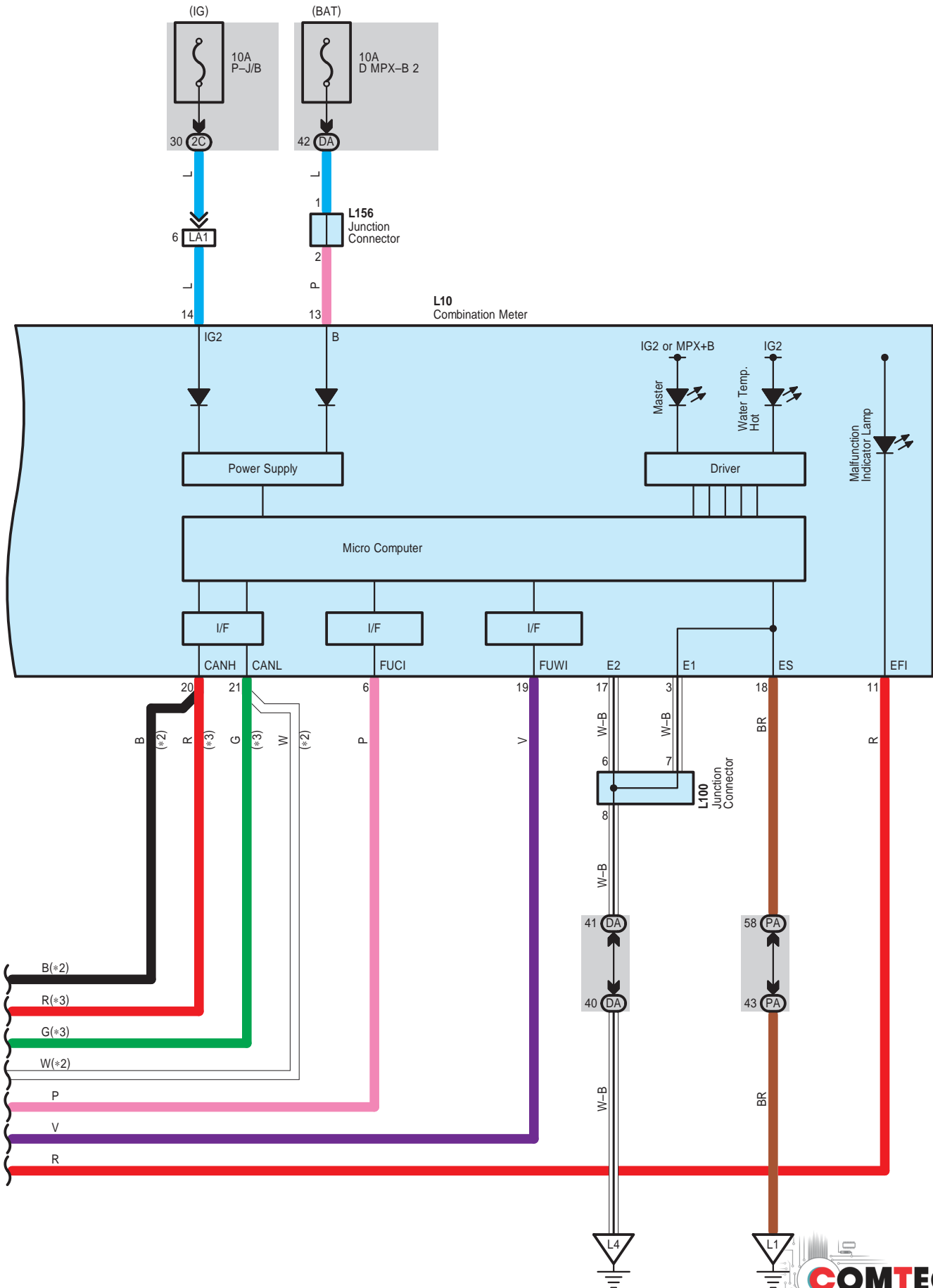



A 13  
White

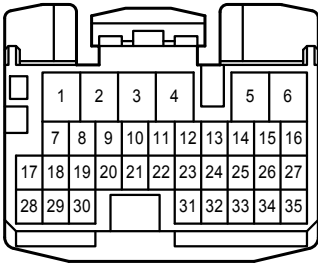

A 14  
White

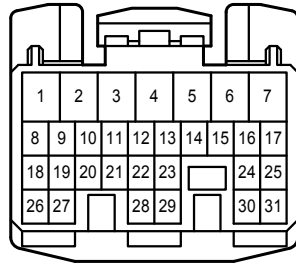

A 16  
Black



A 19  
Black

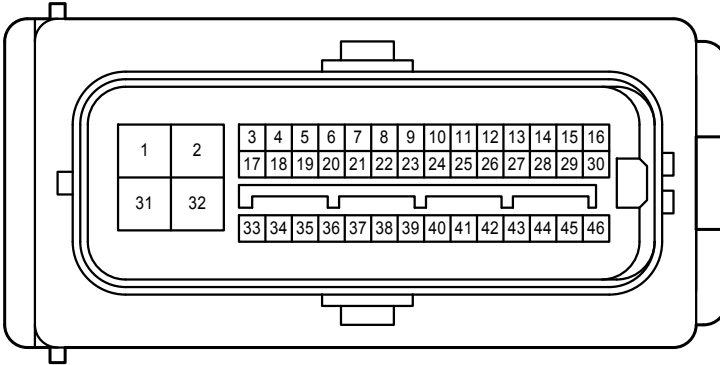

A 21  
Gray

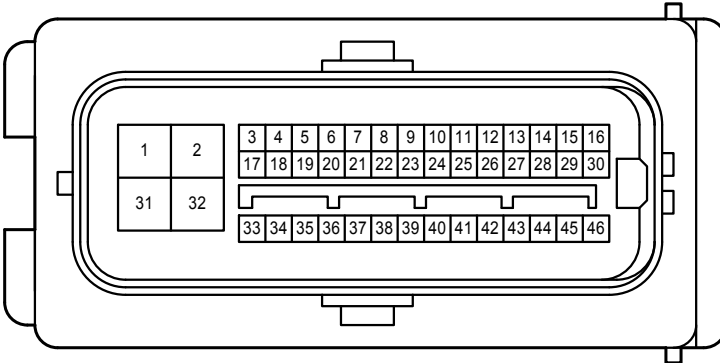

A 36  
Black

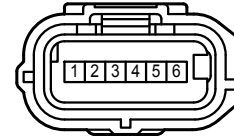

A 60  
Blue

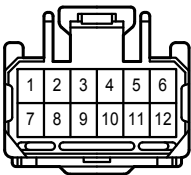

A 61  
Black

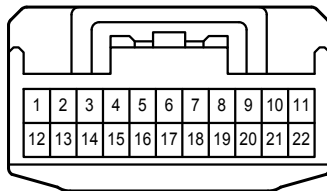

A 62  
Blue

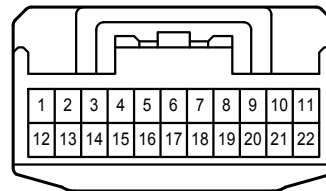

A 63  
Black

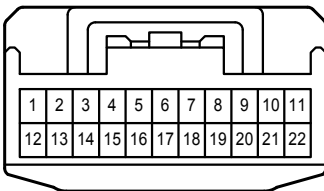

A 64  
Black

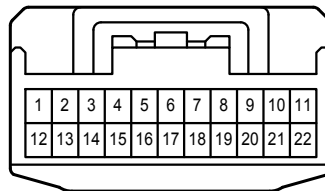

A 67  
Black

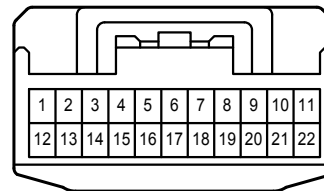

Engine Control

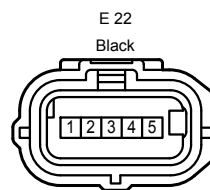
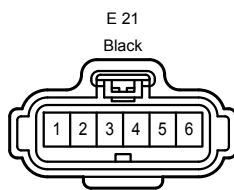
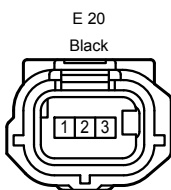
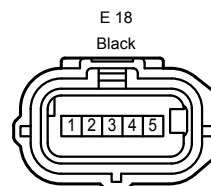
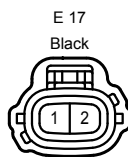
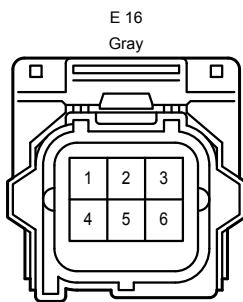
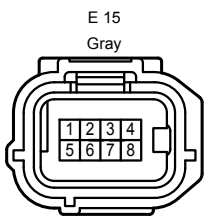
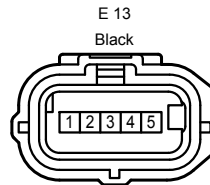
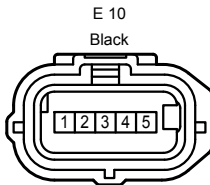
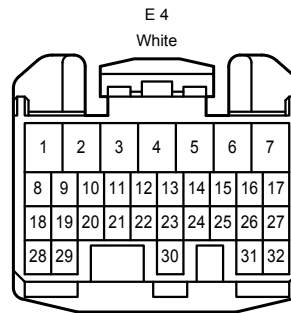
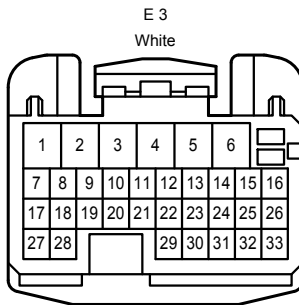
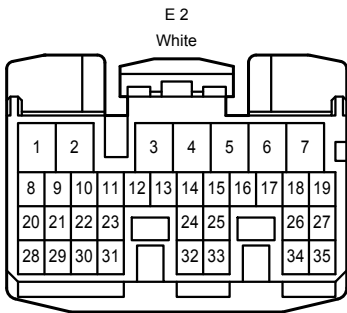
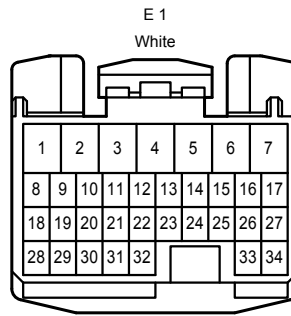
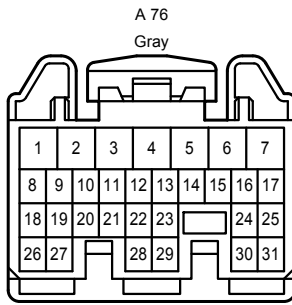
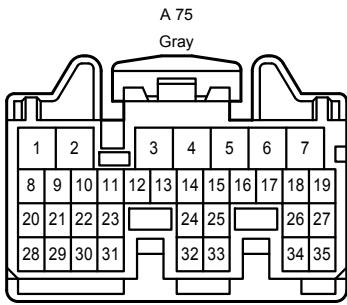
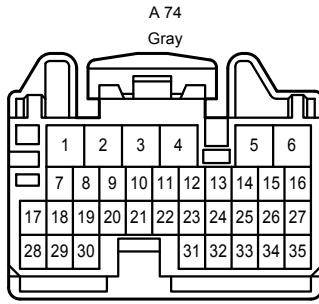
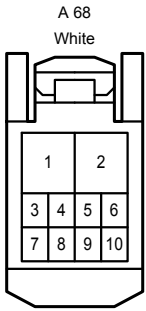

E 27  
Gray

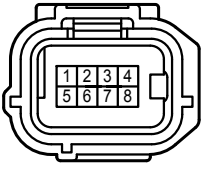

E 28  
Gray

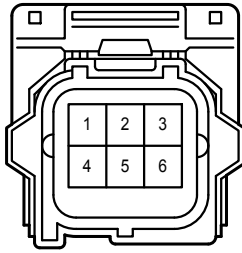

E 30  
Gray

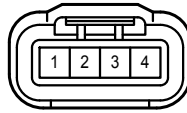

E 31  
Black

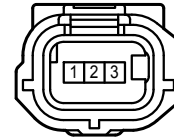

E 32  
Black

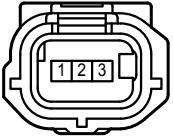

E 33  
Black

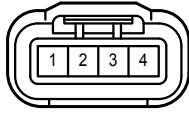

E 34  
Gray

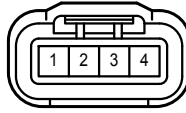

E 35  
Gray

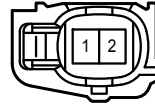

E 36  
Black

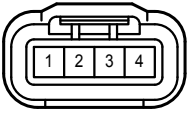

E 38  
Gray

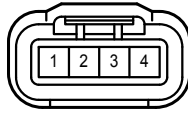

E 39  
Black

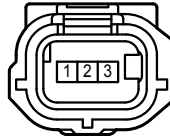

E 40  
Black

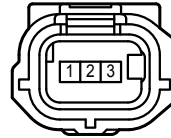

E 41  
Black

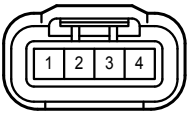

E 42  
Gray

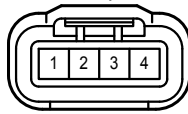

E 43  
Gray

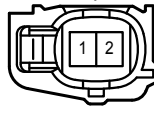

E 44  
Black

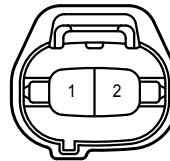

E 45  
Black

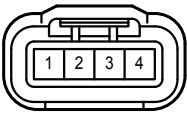

E 46  
Black

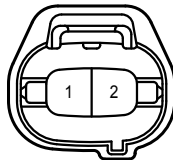

E 47  
Dark Gray



E 48  
Dark Gray



E 51  
Blue

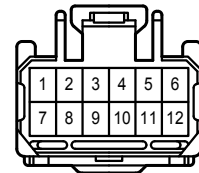

E 52  
Black

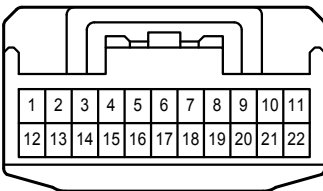

E 53  
Black

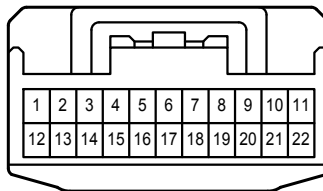

E 54  
Black

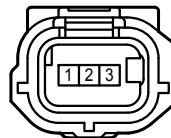

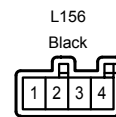
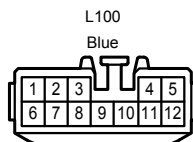
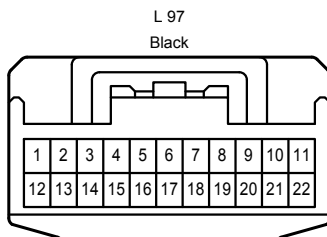
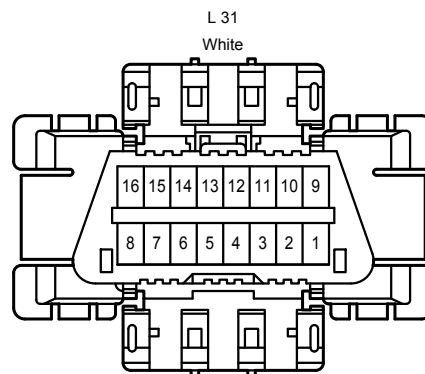
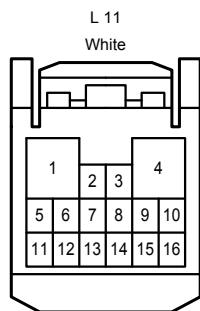
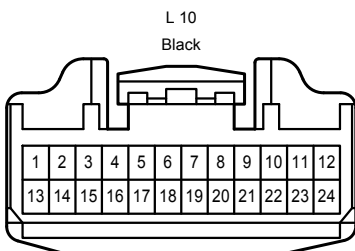
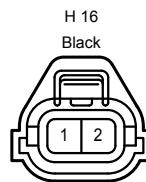
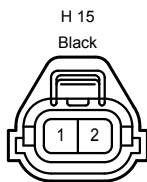
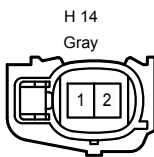
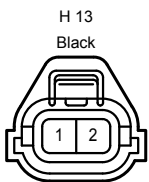
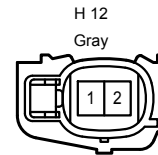
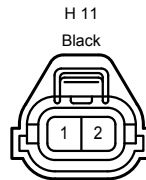
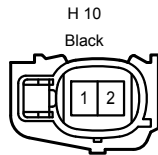
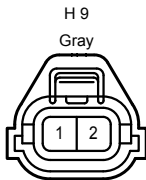
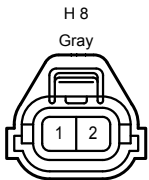
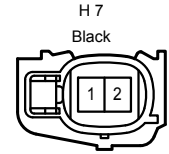
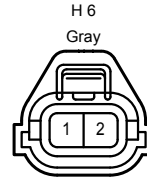
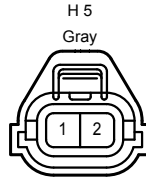
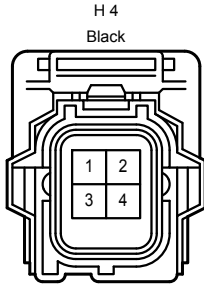
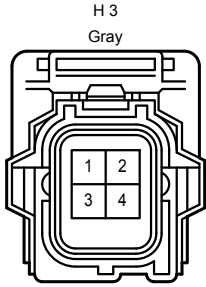
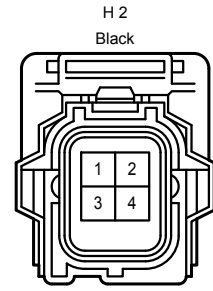
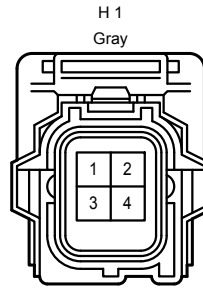
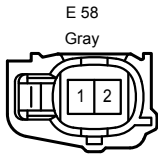
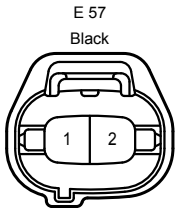

R 42  
Black

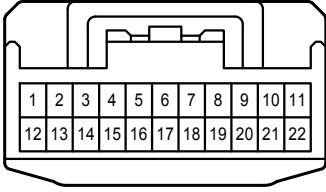

R 44  
Black

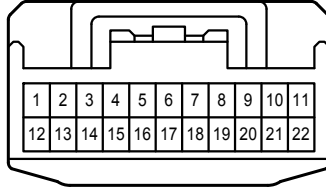

R 59  
Dark Gray



S 11  
White

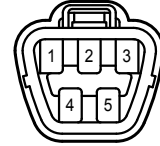

S 56  
White

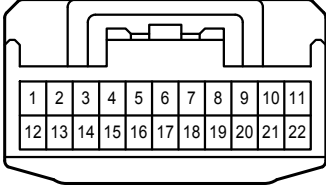

S 57  
White

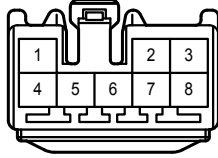

S 71  
Dark Gray



S 72  
White

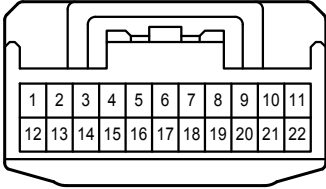

V 1  
Black



m 1  
Black

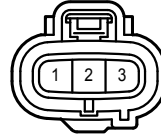

m 2  
Black



z 44  
Black



z 45  
Black



z 46  
Black



z 47  
Black



z 48  
Black

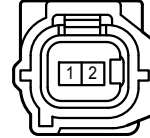

z 49  
Black



z 50  
Black



z 51  
Black



1H



2B

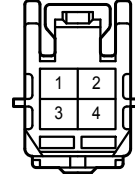

2C  
White

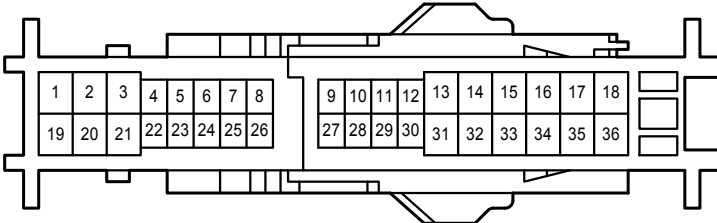

2D  
Black

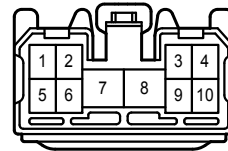

## Engine Control

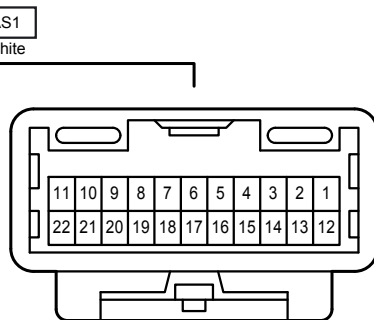
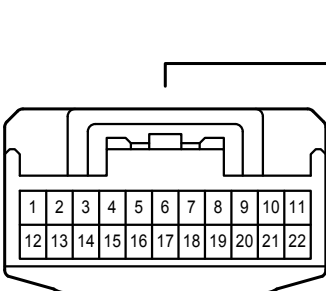
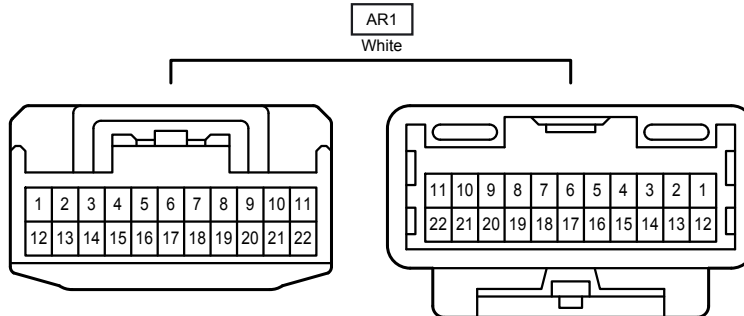
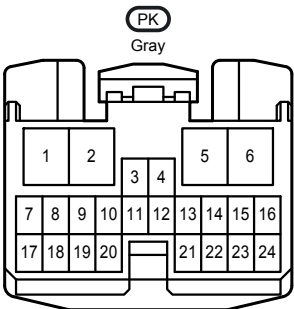
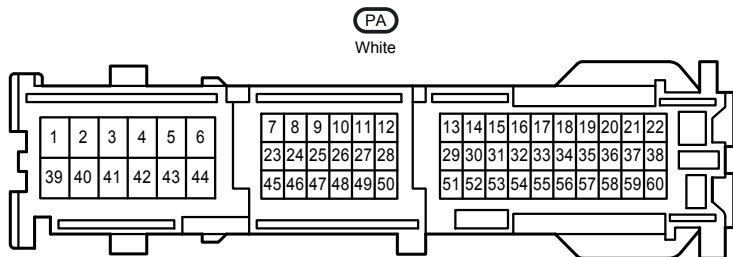
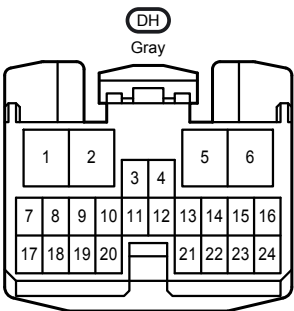
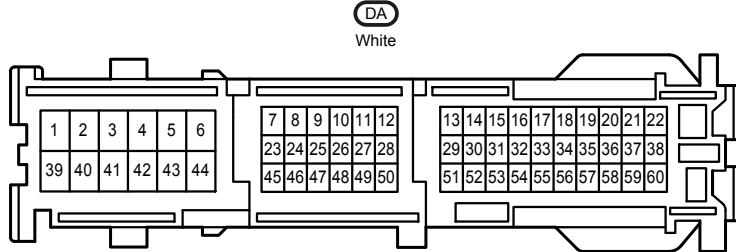
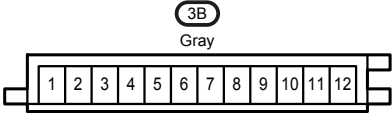
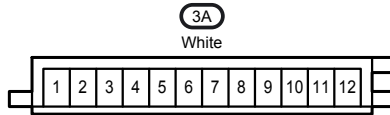
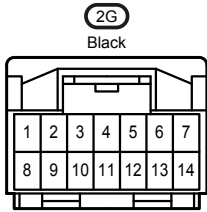
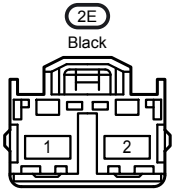

AS2  
White

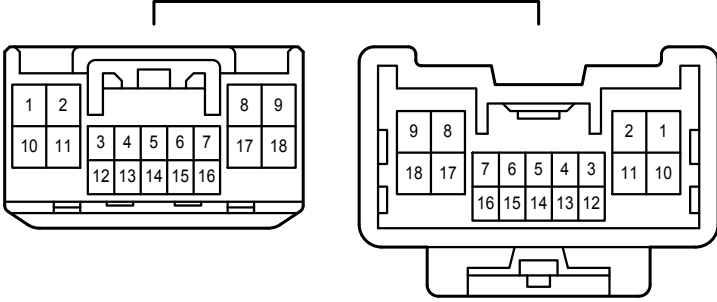

AS5  
White

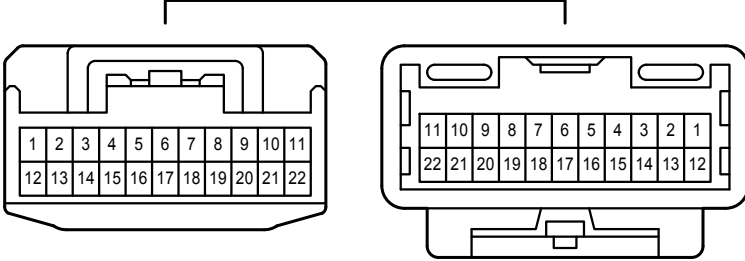

EA1  
White

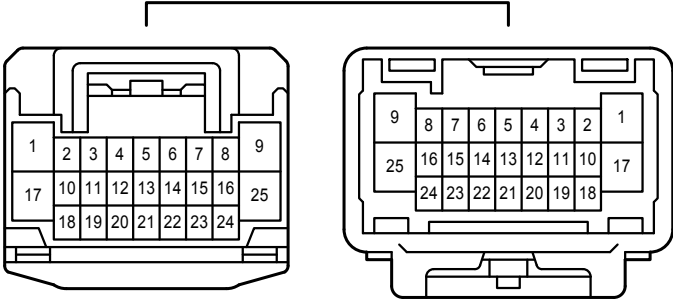

EA2  
White

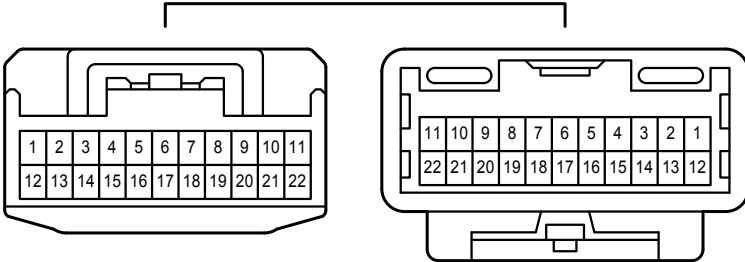

EA3  
White

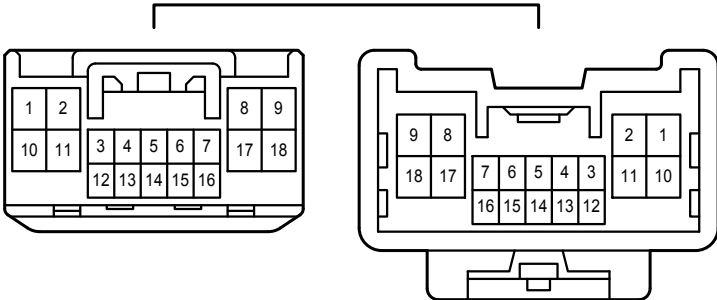

EA4  
White

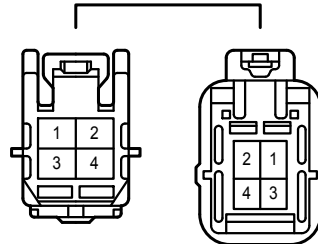

EH1  
Gray

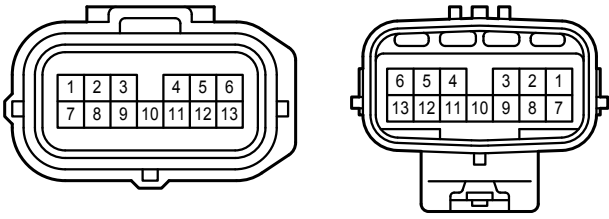

Ez1  
Gray

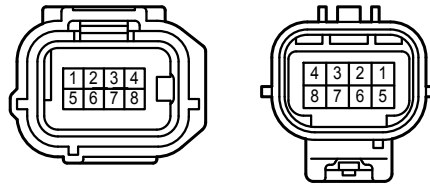

Ez2  
Gray

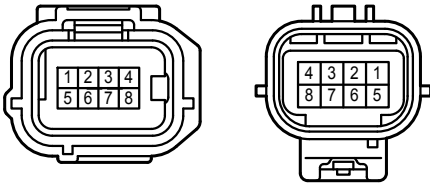

LA1  
White

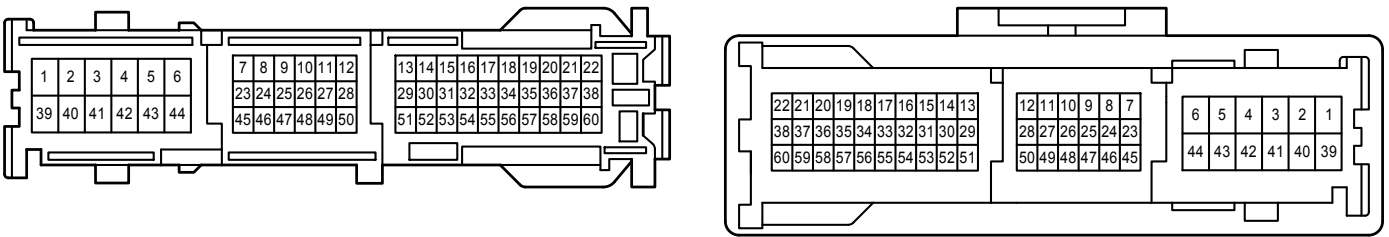

VS1  
Black

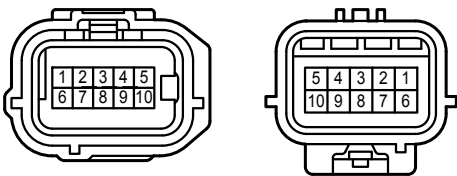

mS1  
White

