

ÊJZË \ìÿ ÉZÆ<Á•ÉZ¼

((€<Ô§ÁZ¼ÀÅ{€•,É¼ZÿÆdÉ^Y€•qu

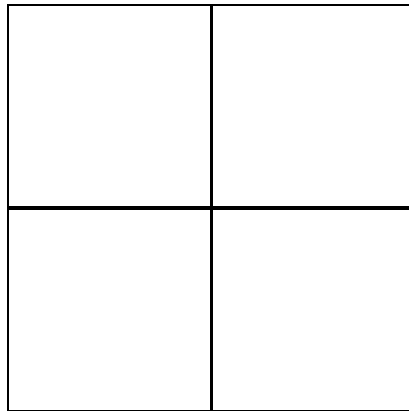

$\{Y \in \mathbb{E} Y$	$\hat{A} \cdot \{ \hat{A} y \cdot \hat{A} c$
<p>• Z / - / ‡ Y • d ¼ / ‡ É Z 9 ¼ Æ ¼ • Z // - ` // q d ¼ // ‡ É Z // Æ ¼ ç Æ ¼ ç ¾ ‹ Á • € 9 Ô À ‹ Ê Z] ¾ ‹ Á • ° W Y { 9 €</p>	<p>DAM: 9076 • Y Å,,a Ó Z] Ä]</p>

Ä » | - »

Ä | Ä { € € Ô § Á Z ¼ Ä Å Y ; ¼ Æ Z Å B S Y € € Y ; ¼ Z ' À Å • Ž iz O e • Ä œ À
 • { • Ä œ À » i È Z ¼ Å Æ] - Y • | À f ^ » ¾ B S I • È Æ | • Y Ä | P Å e d ‡ W € » Á
 Á È J Z È u Y € » † b € ‹ Ô § Ä Á y Z { € Ä Å Y ; ¼ Æ Z Å C Å V € q • Ä • y • { É € • f z
d ‡ Y | È { € ³ Ä W Y • Y ¼

{€//°, ¼ÿ µÂ//•Y
 1 Z 'À Å Z ¼À Å Y • ÉZÆ£Y€q ½ {€ ÉZÆ£Y€q ¼ {€ y ¼ ÂÁ•Á°
 | < Z] Ê » Š y € c

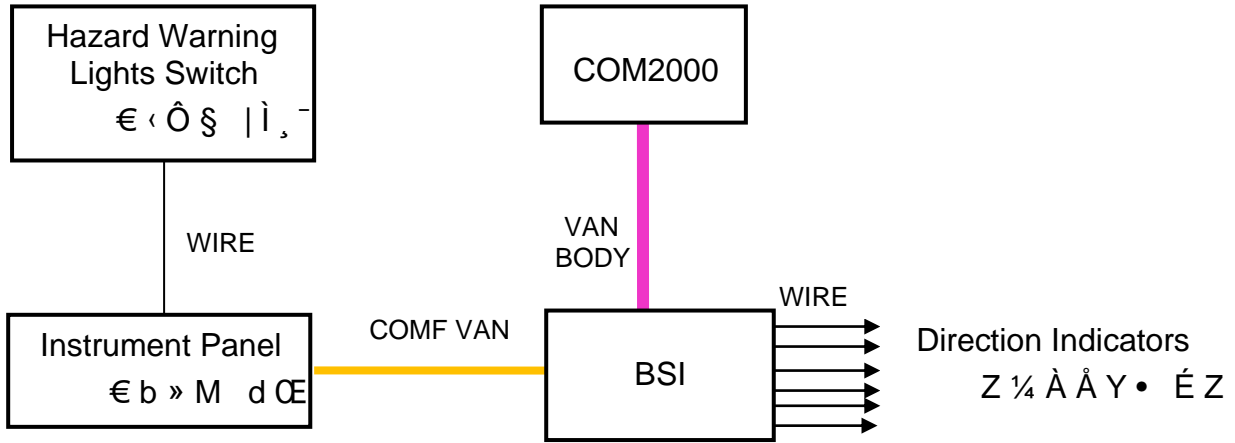

€ < Ô § ÉZÆ£Y
 ZÆ£Y€q ÊBSI €¼M•Yµ€¼ÀÁMÃ¼œµZÉ•Y€¼œ»Ô§|ì,-ªË€—•
 {€ì³Ê»Ã|Æÿ

Z/¼ÀÅY•ÉZÆ£
 Ê°Ë€f°BSI¼œMÀ•Y¼aœCOM2000ÉZÆ£Y¼Àf¼{ªË€—•Yd¼YÁ
 {€ì³Ê»Ã|Æÿ€]



|ìËZ¼¿ ¶•Zu ½ZÀì¼—Y €Ë• {•YÁ»|/YOEËe Zì,¼Y

É€eZ] fZ//f.Á

Á•{DAMNo Ä] ÄnzÄe ÄZ]§ Ê‡•€]

É•Y€/~“Y ÉZ/Æf.Zu dì “Á È/‡

Äf°¿

|Ë•Y{ ½ZÀì¼—Y É,-€» ¶“« ½{Ä] °.Z‡ •Y Ä- |ìËZ¼¿ Ä‡

µÁY {Y€ËY

|¿Ä/¿ Ê¼¿ ¾/¿Á• €/¿Ô§

Á Á•{Äz z f ÄYÁ•PÂ§ ZÄGBOX [ZË \ìÿ ÉZÆÄZ'f‡{ •Y Ê°Ë

|ìËZ¼¿ [Zz f¿,¾MY cZ•Ë•OEË

- ¾ ECU configuration and services
- ¾ Test by ECU
- ¾ Driver information/Communication
- ¾ Instrument panel
- ¾ Parameter measurements
- ¾ State of inputs Instrument panel

Yhazard warning lightspush button"

ZOE§ Y•Z a€ dÔ§“ÁìÁ- |ìË

|ìËZ¼¿ µ€f

|ìËZ¼¿ Ä—

€» °ìZ||ÄZÆfÄYèìò§§

{•Ê‡

€b» M dOEa 'ËÄ e ,|íf§ZË ½ZÀì

{YÄËY

|¿Y¿Z/» ¾/¿Á• °/WYÄ €/¿Ô§ ÉZ

1 Z§If u

'ËÄ e •Y ¶^« ,½MÄ½-Ä]Ê§.Zì‡cÄÄ‡{

|ìËZ¼¿ %o;ÊÄ³§YÄ•Á•ZOE»

